

UNIVERSITY OF TORONTO



3 1761 00483449 5



LIBRARY

ONTARIO COLLEGE
OF
PHARMACY

No. 971

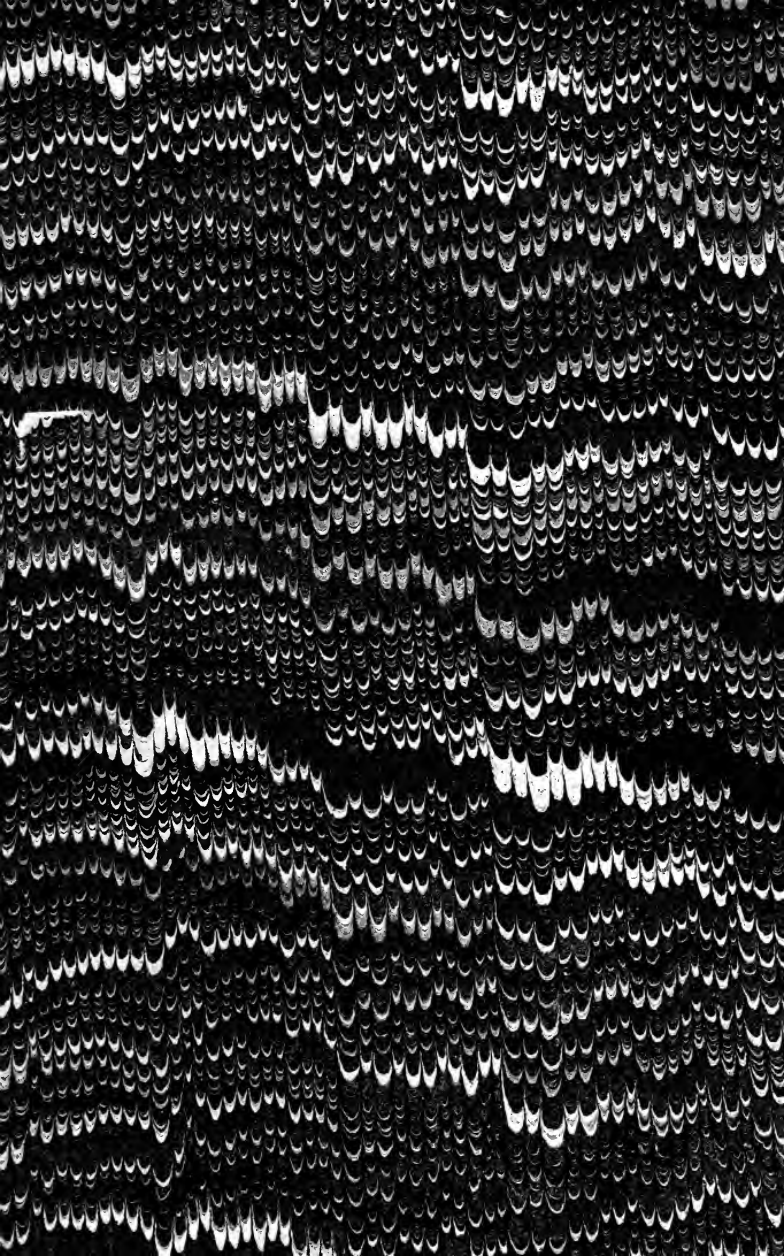

Chemistry ✓

ONTARIO COLLEGE OF PHARMACY,
TORONTO, ONT.

ONTARIO COLLEGE OF PHARMACY,
TORONTO, ONT.

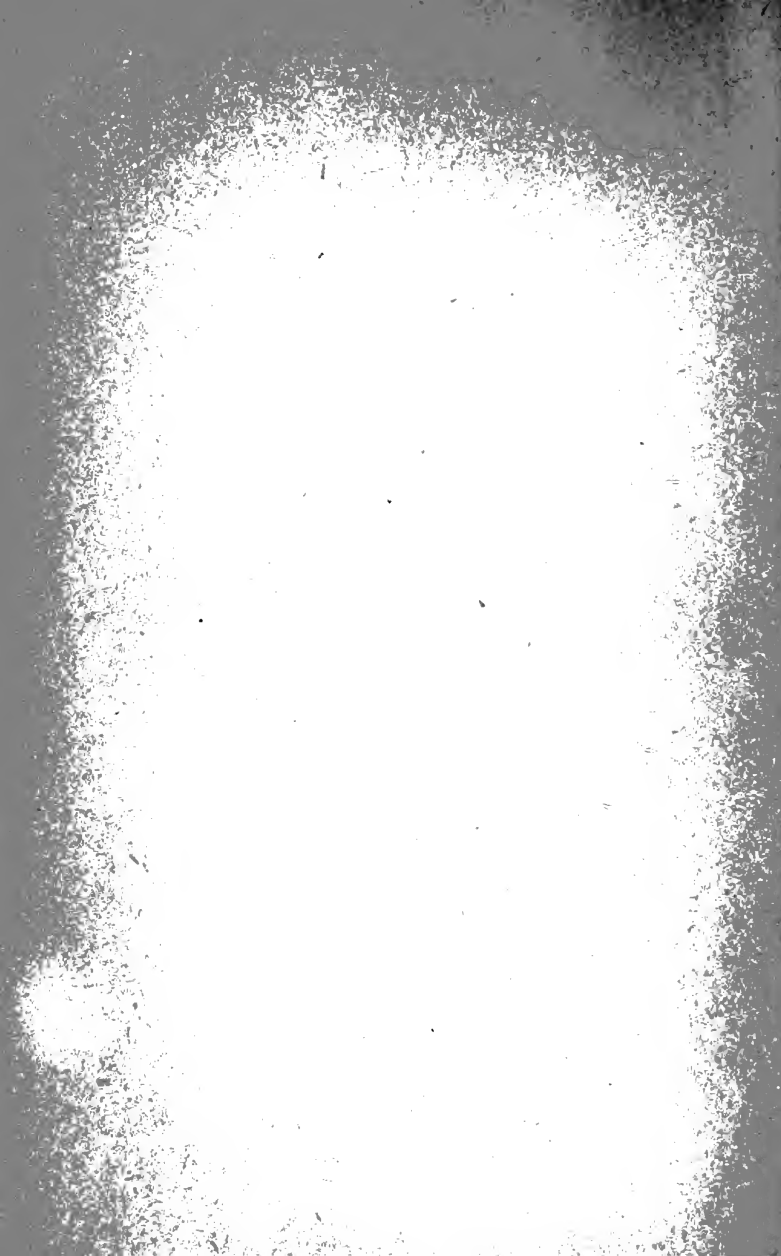

Henry Watton,

8835-

CHEMICAL RECREATIONS:

A Popular Manual

OF

EXPERIMENTAL CHEMISTRY.

By JOHN JOSEPH GRIFFIN,

FELLOW OF THE CHEMICAL SOCIETY,

HONORARY MEMBER OF THE PHILOSOPHICAL SOCIETY OF GLASGOW.

THE TENTH EDITION.

SECOND DIVISION:

NON-METALLIC ELEMENTS.

LONDON:

PUBLISHED BY JOHN JOSEPH GRIFFIN,
119, BUNHILL ROW,
AND RICHARD GRIFFIN AND CO., STATIONERS' HALL COURT.

1860.

THE CHEMISTRY OF ONTARIO
COLLEGE OF PHARMACY
OF THE 44 GERRARD ST. E.
TORONTO,

NON-METALLIC ELEMENTS

AND THEIR COMPOUNDS:

AIR—WATER—THE GASES—THE ACIDS;

AND A SUMMARY OF

ORGANIC CHEMISTRY.

INCLUDING A COMPREHENSIVE

COURSE OF CLASS EXPERIMENTS.

By JOHN JOSEPH GRIFFIN, F.C.S.

ILLUSTRATED BY 440 ENGRAVINGS OF APPARATUS.

L O N D O N :

PUBLISHED BY JOHN JOSEPH GRIFFIN,
119, BUNHILL ROW,
AND RICHARD GRIFFIN AND CO., STATIONERS' HALL COURT.

1860.

[The Author reserves the right of publishing Translations in France and Germany.]

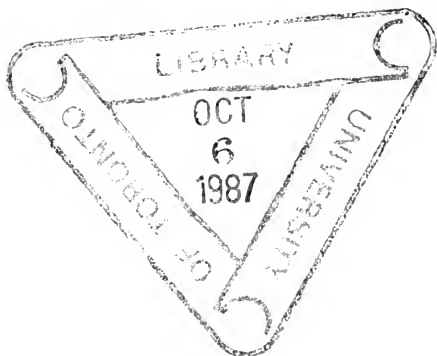

ADVERTISEMENT.

THIS SECOND DIVISION of "CHEMICAL RECREATIONS" is devoted to the investigation of the Non-Metallic Elements, and it consequently embraces the following subjects:—

The Chemistry of Gases and Vapours.

The Chemistry of Acid Radicals and their Salts.

The Chemistry of Plants and Animals.

The Chemistry of Air and Water.

The Chemistry of Combustion and Respiration, of Fuel and of Food.

The FIRST DIVISION of the Work, published a few years ago, contained Introductory Facts and Elementary Experiments.

The THIRD DIVISION, which will complete the Work, and is nearly ready for publication, will contain the Chemistry of the Metals—their Earths, Alcalies, Salts, and Ores.

The present volume contains an extensive course of CLASS EXPERIMENTS, with Instructions for their successful performance, illustrated by several hundred Engravings of the most efficient kinds of apparatus.

The great doctrines of Chemical Philosophy are fully explained in it; and wherever opinions are given without evidence to support them, I have referred to those chapters in my recently-published work on the "*Radical Theory in Chemistry*," where the experimental evidence is quoted fully, and the deductions from it are carefully investigated.

In composing this work I have followed the plan of giving full accounts of substances and theories that are important, and passing

rapidly over things and opinions of lesser moment. If a student of Chemistry masters, theoretically and experimentally, the great points of the science, the subsequent working out of particular details is easy.

All the Tables in this Division have been recalculated to suit the Table of Chemical Equivalents on the Hydrogen scale, which is given in page 123. The Tables which were published in the First Division have also been recalculated on the same basis, and are published in a supplementary form. By that means the processes for Centigrade Testing are all brought into harmony with the theoretical explanations that are given throughout the work.

Scarcely a page of this volume is reprinted from the Ninth Edition without important alterations. I mention this fact as an apology for the time that has elapsed between the publication of the First and the Second Divisions. I may add, as a hint to earnest students, that whoever undertakes, as I have undertaken in this volume, to write a system of Chemistry from an original point of view, will find many things to occupy his attention and consume his time.

Sydenham, December, 1859.

GENERAL INSTRUCTIONS

1. The first part of the report should be a general statement of the purpose of the investigation.

2. The second part should describe the methods used in the investigation.

3. The third part should present the results of the investigation.

4. The fourth part should discuss the conclusions drawn from the results.

CHEMICAL RECREATIONS:

A Popular Manual

OF

EXPERIMENTAL CHEMISTRY.

BY JOHN JOSEPH GRIFFIN,

FELLOW OF THE CHEMICAL SOCIETY,

HONORARY MEMBER OF THE PHILOSOPHICAL SOCIETY OF GLASGOW.

THE TENTH EDITION.

FIRST DIVISION:

ELEMENTARY EXPERIMENTS.

LONDON:

PUBLISHED BY JOHN JOSEPH GRIFFIN,

119, BUNHILL ROW,

AND RICHARD GRIFFIN AND CO., STATIONERS' HALL COURT.

1860.

FIRST COURSE

OF

CHEMICAL EXPERIMENTS:

CONTAINING

AN INTRODUCTORY VIEW OF CHEMISTRY,
INSTRUCTIONS IN CHEMICAL MANIPULATION,
LESSONS ON THE QUALITATIVE ANALYSIS OF SALTS,
THE ART OF CENTIGRADE TESTING,
AND TABLES OF CHEMICAL EQUIVALENTS.

By JOHN JOSEPH GRIFFIN, F.C.S.

ILLUSTRATED BY ONE HUNDRED ENGRAVINGS OF APPARATUS.

L O N D O N :

PUBLISHED BY JOHN JOSEPH GRIFFIN,
119, BUNHILL ROW,
AND RICHARD GRIFFIN AND CO., STATIONERS' HALL COURT.
1860.

[The Author reserves the right of publishing Translations in France and Germany.]

P R E F A C E.

THIS work is offered as a Manual of Experimental Chemistry for the use of beginners. The author has two classes of readers particularly in view, namely, Students attending Lectures or Lessons on Chemistry, and Schoolmasters who desire to teach the Elements of Chemistry, in Popular Lectures or Experimental Lessons. Both of these classes of readers will find useful information in the following pages. The author has endeavoured to elucidate most effectively those subjects which urgently demand the notice of beginners. Thus, he has given ample accounts of Air, Water, Earths, Acids, Useful Metals, and Common Salts, while subjects of less importance are passed unnoticed.

The experiments selected to illustrate the subjects fixed upon are striking and convincing, and such as can be performed with facility and economy. The precautions necessary to insure success and safety are detailed; and, as far as possible, the experiments are *exhibited* by means of numerous figures of apparatus, many of which represent new and simplified instruments, specially intended to aid the researches of young chemists. This is particularly the case with apparatus adapted to micro-chemistry, or the art of experimenting on minute quantities. But, independently of the course of easy experiments, another series has been introduced, to explain the methods by which the most important facts of the science are demonstrated with precision.

The chapters describing Elementary Experiments are written in a peculiar style, to show in what manner the elements of practical chemistry can be taught to large classes of students in schools. The chapter on the "Qualitative Analysis of Salts" is a sequel to the elementary experiments. It is an Introduction to Analysis for the use of *very*

young chemists. After mastering these chapters, the reader will easily comprehend the use of the Tables of Tests given in subsequent chapters of the work.

The TABLES will be found to contain a mass of useful information, conveyed, I hope, intelligibly.

The experimental portion of the work is not confined to chemical recreations or to experiments of demonstration, but includes much information relating to analytical processes. In particular, it embraces an account of a new method of preparing test liquors of fixed strength, and of applying such liquors, by means of graduated decimal measures, to the rapid analysis of acids, alcalies, and salts. This method of testing is equally useful to students of chemistry and to persons professionally engaged in the chemical arts. Among the applications of which it is susceptible, is that of determining the strength and purity of the chemical preparations used in medicine.

The author has the pleasing task of expressing his gratitude for the favourable reception accorded to nine preceding editions of this work; and, on presenting the TENTH EDITION, which he has endeavoured to render worthy of continued patronage, he indulges in the hope that it will still be found entitled to rank with books of practical utility.

The work will be published in THREE DIVISIONS:—

- I. ELEMENTARY EXPERIMENTS.—General Doctrines of the Science; Introduction to Analysis; Chemical Manipulation; Centigrade Testing; Tables.
- II. THE METALLOIDS and their Combinations with one another; Air; Water; The Gases; The Acids. With a Summary of Organic Chemistry.
- III. THE METALS and their Earths, Alcalies, Salts, and Ores.

LONDON, *December*, 1853.

CONTENTS.

FIRST DIVISION.

	PAGE
Introduction	I
Nature, Objects, and Uses of Chemistry	I
Reasons why Chemistry should be a branch of General Education	2
Methods of Chemical Research	4
Chemical Elements	9
Elements that occur in Plants and Animals	14
Elements that occur in Minerals	14
Causes of Chemical Combination and Decomposition	15
Chemical Equivalents	18
Elementary Experiments	31
Alteration of Vegetable Colours by Acids and Alkalies	31
Bleaching of Vegetable Colours by Chlorine	36
Chemical Metamorphoses	37
Experiments with Coloured Liquors and Sympathetic Inks	37
Chemistry for Holidays	45
Chemical Operations and Phenomena	49
Solution 49	53
Evaporation 51	56
Precipitation 51	56
Testing 51	56
Dissolving Powers of different Liquids 52	57
Discrimination of Vegetable, Animal, and Mineral Bodies	58, 70
Crystallisation	53
Efflorescence	56
Deliquescence	56
Effervescence	56
Sublimation	57
Filtration	58, 70
Qualitative Analysis of Salts	65
Substances to be sought for	65
Apparatus required by each Student	66
Apparatus required by a Class	83
Salts suitable for analysis by this method	67
Preparation of a Solution for examination	68
Classification of Tests	71
I. Indicating Tests	71
A. Testing for Metals	71
B. Testing for Acids, or Classes of Salts	78

	PAGE
2. Confirming Tests	83
A. Confirming Tests for Metals	84
B. Confirming Tests for Acids	91
Assay Note	73, 81
Interpretation of the Results of an Analysis	81
 Centigrade Testing, or the Performance of Analytical Experiments by Means of Equivalent Test Liquors and Graduated Instruments	 97
Apparatus required for Centigrade Testing	97
Table of Imperial Liquid Measures divided Decimally	98
Centigrade Test Tubes, or Alcalimeters	99
Test Mixers, Pipettes and their uses	101
Preparation of Standard Test Solutions	103
Carbonate of Potash of $2\frac{1}{2}$ degrees	103
Carbonate of Soda of $2\frac{1}{2}$ degrees	103
Sulphuric Acid of 5 degrees	104
Oxalic Acid of 5 degrees	105
Solubility of Acids and Alcalies in Water	105
Table of Solutions of Acids and Alcalies	106
Relation of Bibasic to Monobasic Salts	107
Explanation of Terms: Degree of Strength, Test Atom, &c.	108
Preparation of Equivalent Test Liquors	108
A. Alcalies	108
Testing of Liquid Ammonia	108
Method of Calculating the Results of Analyses	108, 110
Preparation of Ammonia of 5 degrees	109
Description of the Ammonia Meter	109
Caustic Potash and Caustic Soda of 5 degrees	110
B. Acids	110
Testing of Nitric Acid	110
Preparation of Nitric Acid of 5 and 10 degrees	111
Preparation of Hydrochloric Acid of 10 degrees	111
General Observations on the Process for Testing the Strength of Acids and Alcalies	111
Application of Centigrade Testing to Mercantile and Manufacturing Products	112
Carbonate of Soda 112 Limestones and Marls	113
Vinegar 112 Ammonia	114
Table of Test Equivalents of Acids and Alcalies	114
Miscellaneous Experiments with Equivalent Test Liquors	115

CONTENTS.

SECOND DIVISION.

	PAGE
The Radical Theory	121
Definition of the terms Radical and Salt	121
Equivalent Weights of the Elementary Radicals	123
Compound Radicals	125
Discrimination of Radicals into Acid and Basic	126
Classification of Elementary Radicals	126
Class I. The only Element that does not act as a Radical.	
II. The Element which acts against the Metals as an Acid Radical, and against the Metalloids as a Basic Radical.	
III. Elements which produce Acid Radicals.	
IV. Elements which produce Basic Radicals.	
The Relation of Basyloous to Basylic Radicals	128
Conditions which govern the Transmutations of Radicals	129
The Construction of Chemical Formulæ	131
Distinction between Analytical and Synoptical Formulæ	362
Systematic Chemical Nomenclature suggested	132
The Constitution of Acids and Vapours	135
Gasifying Powers of Radicals, a table exemplifying the causes which modify the Atomic Measures of Compound Gases	138
Table showing the Composition, Specific Gravities, Atomic Weights, and Atomic Measures of Gases and Vapours	140
Uselessness of assigning imaginary gaseous volumes to the Atomic Weights of Non-volatile Radicals	149
1. Oxygen	152
Character and properties of Oxygen	152
Oxides—their origin and nature	153
Important consequences that result from the fact that one equi- valent of Water contains two equivalents of Hydrogen	154
Explanation of the terms Oxidation and Reduction	155
Theory of the Oxidising action of Permanganic Acid	157
Different methods of preparing Oxygen Gas	159
Methods of collecting Gases	166

	PAGE
Receivers for Gases, Gas-bags, &c.	167
Gas-holders of various constructions	170—176
Pneumatic Troughs	171—178, 317
General Observations regarding the Management of Gases	178
The proper fitting of Gas-bottles	178
Precautions to be observed in collecting Gases	180
Experimental Illustrations of the properties of Oxygen Gas	180
Combustion of a candle in Oxygen Gas	181
Products of Combustion in Oxygen	181
Combustion of Charcoal in Oxygen Gas	182
Combustion of Sulphur in Oxygen Gas	184
Combustion of Phosphorus in Oxygen Gas	184
Combustion of Metals in Oxygen Gas	186
Oxygen Gas blowpipes	188
2. Hydrogen	
Character and properties of Hydrogen	191
Preparation of Hydrogen Gas	192
Various methods of fitting up Gas-bottles	192
Theory of the production of Hydrogen Gas	195
Apparatus and materials for washing and drying Gases	197
Experiments illustrating the properties of Hydrogen Gas	199
Experiments on Explosive mixtures of Oxygen and Hydrogen	204
Oxyhydrogen blowpipes and the Lime Light	207
COMPOUNDS OF OXYGEN AND HYDROGEN	
<i>a.</i> <i>Water</i> = HHO. Its constitution and properties	210
Solvent powers of Water, and Colours of Solutions	211
Methods of Composing Water from its elements	212
When Hydrogen is burnt with Oxygen, the product is	
Water	213
The Gases combine in the proportions of $H^2 + O^1$ by	
measure	214
Eudiometry	214
Ettling's Gas Pipette	218
Water contains 16 parts of Oxygen to 2 parts of Hy-	
drogen by weight	219
Methods of decomposing Water into its elements	223
Decomposition by the Alkaline Metals	223
Galvanic Decomposition of Water	224
Delivery of the two Gases in one vessel	224
Delivery of the two Gases in separate vessels	225
Voltaic preparation of pure Hydrogen Gas	227
Galvanic Decomposition of Neutral Salts	228

	PAGE
The Galvanic Battery	228
Bunsen's Charcoal Battery	229
Smee's Battery	232
Theory of the Galvanic Decomposition of Water	234
Theory of the Galvanic Decomposition of Salts	235
Purification of Water. Process of Distillation	236
Still, Condensers, Retorts, Receivers, &c.	237—243
Tests of the Purity of Water	244
b. <i>Oxygenated Water</i> = HO	244
c. <i>Ozone</i> = HO ²	246
Preparation of Ozone	247
Tests for Ozone	248
Properties of Ozone	248
Critical Examination of the question, whether Ozone is a Simple or Compound Substance	250
Ozonides and Antozonides	250
3. Nitrogen	
Character and properties of Nitrogen	259
Preparation of Nitrogen Gas	259
Experiments illustrating the properties of Nitrogen Gas	263
ATMOSPHERIC AIR	264
Properties of Atmospheric Air	264
Its Formation and Analysis	266
Quantitative Estimation of its Carbonic Acid and Water	267
Quantitative Estimation of its Nitrogen and Oxygen	269
Easy Experiments illustrating the characteristic properties of Atmospheric Air	271
The AIR-PUMP and PNEUMATIC APPARATUS for experiments on the Physical Properties of Air	273
Compressibility and Elasticity of Air	273
The Air-Syringe	274
Technical account of Stopcocks, Connectors, &c.	275
Process of Exhausting Air from vessels	276
Method of determining the Specific Gravity of a Gas	277
The Air-pump described	278
Tate's Double-action Air-pump	279
Air-pumps with double barrels	282
Experiments with the Air-pump	284
Evaporation in vacuo	284
Freezing of Water in vacuo	285
Fountain in vacuo	285
COMPOUNDS OF NITROGEN AND OXYGEN	286
Nitrous Oxide = NNO. Laughing Gas	287

	PAGE
Nitric Oxide = NO	289
Nitrous Acid = NNO^{s}	291
Peroxide of Nitrogen = NO^{s}	292
Anhydrous Nitric Acid = NNO^{s}	293
THE DOCTRINE OF THE ANHYDRIDES	295
NITRIC ACID AND THE NITRATES	294
Properties of the Nitrates = MNO^{s}	297
Preparation and purification of Nitric Acid = HNO^{s}	298
Apparatus suitable for distilling Acids	299—301
Strength of Nitric Acid, Table A	303
" " Table B	305
Explanation of the Tables of the Strength of Nitric Acid	304
Table of Reciprocals for determining the Atomic Measure of Acids or other liquid tests	307
Oxidising power of Nitric Acid	308
Signification of the term <i>powerful oxidising agent</i>	308
Nitric Acid considered as a Solvent	310
Phenomena which occur during Solution in Nitric Acid	310
Substances soluble in diluted Nitric Acid	311
Substances insoluble in diluted Nitric Acid	311
Substances soluble in concentrated Nitric Acid	312
Substances insoluble in concentrated Nitric Acid	312
Nitrites and Nitrous Acid	313
AMIDOGEN, AMMONIUM, AMMONIA	313
Ammonia, or Hydride of Amidogen	314
Theory of Amidogen and Ammonium Salts	315
Preparation of Ammonia Gas	316
Management of Gases that are soluble in Water	316
The Mercurial Pneumatic Trough	317
Experiments illustrating the properties of Ammonia Gas	320
Condensation of Ammonia Gas to the liquid state	323
Production of Ammonia from its elements	323
Analysis of Ammonia	324
Extraction of Ammonia from Bones	325
Bone-black, Bone-ash, &c.	326
Liquid Ammonia (Solution of Ammonia in Water)	327
Table of the Strength of Solutions of Ammonia in Water	329
Preparation of Aqueous Solution of Ammonia	330
Uses of Liquid Ammonia as a test, &c.	333
4. Carbon	334
Characteristics of Carbon	334
Experiments illustrating the properties of Carbon	335

	PAGE
COMPOUNDS of CARBON and OXYGEN	340
<i>a. Carbonic Acid</i> = CO^2	340
Preparation of Carbonic Acid Gas	341
Production of Carbonic Acid Gas by fermentation	343
Experiments with Carbonic Acid Gas	344
Saturation of Liquids with Carbonic Acid Gas	348
Soda-water Apparatus	348
Saturation of Solids with Carbonic Acid Gas	352
Manufacture of Bicarbonate of Soda	352
Protection of liquids against the Carbonic Acid of the air	355
<i>b. Carbonic Oxide</i> = CO	356
<i>c. The Carbonates and the Oxalates compared</i>	359
Reactions of the Carbonates	361
Properties of the Carbonates	363
Testing of Carbonates for technical purposes	364
Kerr's process	364
Fritsche's process	365
Rose's process	366
Will's process	366
Geissler's process	367
Modification of it	367
Mohr's process.	368
Griffin's process	113
Properties of the Oxalates	368

Compounds of Carbon, Oxygen, and Hydrogen.

OXALIC ACID = HCO^2 . Its Preparation and Properties	370
ULTIMATE ANALYSIS OF THE ORGANIC COMPOUNDS WHICH CONTAIN CARBON, HYDROGEN, AND OXYGEN	371
THE OXALATES AND CARBONATES OF AMMONIA, AND THE COMPOUNDS PRODUCED BY THEIR DECOMPOSITION	378
A. The Oxalates of Ammonia	378
Oxamid	378
Oxamic Acid	379
Cyanogen	380
B. The Carbonates of Ammonia	380
Carbamic Acid	380
Carbamid	381
Urea	381
C. The Nitrogen of Cyanogen restored to the Ammoniacal condition	381

Organic Compounds 383

Neutral Organic Compounds	384
Vinylate, Sugar, Starch, Gum, Wood	384
Compound Organic Radicals,—their probable origin	386
Examples of Fruit Essences produced by Sugar	387
Products of the Metamorphoses of Sugar	389

	PAGE
Explanation of the doctrine of Metamerism	390
Principle upon which Compound Radicals are classified.	390
Chemical Equivalence of Compound Radicals	391
Discrimination of Compound Radicals into Acid and Basic	392
The Neutral Compound Organic Radical Vinyl = CH ²	393
Salts of Vinyl. The Glycol Theory	397
CLASSIFICATION OF COMPOUND RADICALS	400
Group A. Basic Radicals of the Vinyl series	401
" B. Acid Radicals of the Vinyl series	402
" C. Acid Radicals of the Succinic series	403
" D. Acid Radicals related to the Polybasic Vegetable Acids (Citric, Malic, Gallic, &c.)	404
" E, F, G. <i>Doubtful Radicals</i>	407
" H. Basic Radicals of the Aromatic series	407
" I. <i>Doubtful Radicals</i>	408
" K. Acid Radicals of the Aromatic series	408
" L, M, N, O, P. <i>Uncertain Radicals</i>	410—412
CONSTITUTION OF VICE-RADICALS	413
I. Salts produced by Organic Radicals, arranged in Groups or Series	414
A. COMPOUNDS PRODUCED BY BASIC RADICALS.	414
<i>In the following list R^p signifies a Basic or Positive Compound Radical.</i>	
1). H,R ^p . Hydrides of Positive or Basic Radicals	414
2). R ^p +R ^p . Compounds of Basic Radicals with one another	414
3). R ^p ,R ^p O. Protoxides. Ethers	415
4). R ^p ,R ^p O. Compound Ethers.	415
5). H,R ^p O. Hydrated Oxides. Alcohols	415
6). R ^p Cl. Chlorides	416
7). R ^p I. Iodides	416
8). R ^p Br. Bromides	416
9). R ^p S. Sulphides	416
10). R ^p S + HS. Acid Sulphides	416
11). R ^p ,CN. Cyanides	416
12). R ^p S + CyS. Sulphocyanides	417
13). R ^p SO ² . Sulphates	417
14). R ^p R ^p ,S ² O ³ . Sulphites	417
15). R ^p NO ³ . Nitrates	417
16). R ^p NO ² . Nitrites	417
17). R ^p CO ² . Oxalates	417
18). R ^p ,R ^p O ² . Organic Salts, Acetates, Benzoates, &c.	417
19). R ^p R ^p ,CO ³ . Carbonates	417

	PAGE
20). $R^pSO^2 + HSO^2$. Bisulphates (Conjugated sulphates) . . .	417
21). Compound Ammonias of various kinds . . .	419
22). Hydrated Oxides of Compound Ammoniums . . .	419
23). R^p,CNO . Cyanates . . .	420
24). Urea . . .	420
25). Compound Ureas . . .	420
B. COMPOUNDS PRODUCED BY ACID RADICALS . . .	420

In the following list R^n signifies an Acid or Negative Compound Radical.

26). H, R^n . Hydrides of Negative Radicals . . .	420
Discrimination of Five kinds of Hydrocarbons . . .	421
27). R^n, R^nO . Protoxides of Negative Radicals . . .	421
28). R^p, R^nO . Ketones, or Acetones . . .	421
29). H, R^nO . Aldides, or Aldehyds . . .	422
30). H, R^nO^2 , or H, R^nO^3 . Hydrated Organic Acids . . .	422
31). $\left. \begin{matrix} R^n, R^nO^2 \\ R^n, R^nO^3 \end{matrix} \right\}$ Anhydrides, or Anhydrous Acids . . .	423
32). $H, R^nO^2 + H, HO$, or H^3, R^nO^3 . Polybasic Acids . . .	424
a. Bibasic Nature of the Carbonates . . .	424
b. Bibasic Nature of the Salicylates . . .	424
c. Bibasic and Tribasic Phosphates . . .	424
d. Polybasic Acetates . . .	425
e. Polybasic Vegetable Acids . . .	425
f. Malic Acid . . .	426
g. Citric Acid . . .	427
h. Bibasic Acids of the Succinic group . . .	428
i. The Glycerides . . .	428
33). NH^4, R^nO^2 . Ammonium Salts with Compound Acid Radicals. . .	430
34). NH^2, R^nO . Amidogen Salts with Compound Acid Radicals. . .	430
Reactions of the Amids . . .	431

II. Special Examples of Organic Salts . . . 432

FIRST SERIES. SALTS PRODUCED BY ACID RADICALS . . .	432
Acetic Acid = $H, C^2H^3O^2$. . .	432
Produced by the destructive distillation of dry wood . . .	432
Examination of the decomposition and its products . . .	433
Theory of the formation of the vinegar . . .	434
Other methods of producing Acetic Acid and Vinegar . . .	435
From Alcohol . . .	435
From Wine and from Malt . . .	436
Properties of Acetic Acid . . .	437
Tables of the strength of Acetic Acid . . .	438, 441
Methods of testing Acetic Acid. . .	437, 439, 443

	PAGE
Strength of commercial Vinegars	440
Examination of Adulterated Vinegars	442
Acetates	444
Acetic Anhydride = $C^2H^3, C^2H^3O^3$	444
Aldehyd = H, C^2H^3O	445
Chloral = H, C^2Cl^3O	446
Acetone = CH^3, C^2H^3O	446
Aldehydic Acid = $H, C^2H^3O + H, C^2H^3O^2$	446
Acetic Oxychloride = Cl, C^2H^3O	447
Acetamid = NH^2, C^2H^3O	448
Formic Acid = H, CHO^2	448
Lactic Acid = $H, C^3H^5O^3$	450
Lactates. Lactide. Lactamid. Alanine	451
Butyric Acid = $H, C^4H^7O^2$	452
Valerianic Acid = $H, C^5H^9O^2$	453
On Fats, Oils, and Soaps. The Glycerine Theory	454
Special Oils and Fats	456
The Solid Fats	456
Theory of Soap-making and Candle-making	458
Stearic Acid = $H, C^{18}H^{35}O^2$	459
Margaric Acid = $H, C^{17}H^{33}O^2$	459
Palmitic Acid = $H, C^{16}H^{31}O^2$	460
Oleic Acid = $H, C^{18}H^{33}O^2$	469
Metamorphoses of Fatty Acids by Oxygen	461
Succinic Acid = $H, C^2H^2O^2$	463
Tartaric Acid = $H, C^2H^2O^3$	463
Constitution of the different orders of Tartrates	464
Citric Acid = $H, C^2H^3O^3 + H, C^3HO^2 + H, C^2HO^2$	465
Constitution of the Tribasic Citrates	466
Malic Acid = $H, C^2H^3O^3 + H, C^2HO^2$	467
Gallic Acid = $H, C^3H^3O^2 + H, C^2HO^2 + H, C^2HO^2$	469
Tannic Acid or Tannin = $H, C^3H^3O^2 + H, C^2HO^2 + H, C^2HO^2$	471
Uses of Tannin. Ink-making and leather-making	473
Pyrogallic Acid = CH, CHO	474
Benzoic Acid = $H, C^7H^5O^2$	474
Preparation of Volatile Acids by sublimation	474, 475
 SECOND SERIES. SALTS PRODUCED BY BASIC RADICALS.	 476
Isolation of Compound Organic Radicals	476
Salts of Ethyl. [Ethyl = C^2H^5]	477
Alcohol = H, C^2H^5O	477
Produced by the fermentation of sugar	477
Produced from Vinyl (olefiant gas)	478
Process of fractional distillation described	478

	PAGE
Rectification of Alcohol	479
Properties of absolute Alcohol	479
Table of Spirits of Wine (Tralles)	480
Alcohol as a Solvent	481
Nature of Fermented liquors	481
Distilled Alcoholic liquors	482
Liqueurs and Compound Spirits	482
Ether = C^2H^5, C^2H^5O	483
Preparation of Ether	483
The continuous process	483
Rectification of Ether	483
Properties and Uses of Ether	484
Theory of the production of Ether from Alcohol	485
Sulphate of Ethyl = C^2H^5, SO^2	486
Sulphovinic Acid = $C^2H^5, SO^2 + HSO^2$	486
Chloride of Ethyl = C^2H^5, Cl	487
Acetate of Ethyl = $C^2H^5, C^2H^3O^2$	487
Oxalate of Ethyl = C^2H^5, CO^2	488
Salts of Methyl. [Methyl = CH^3]	489
Methylic Alcohol, or Wood Spirit = H, CH^3O	489
Hydride of Methyl, Marsh Gas = H, CH^3	490
Davy's Safety Lamp	491
Chloroform = H, CCl^3	492
Salts of Amyl. [Amyl = C^5H^{11}]	493
Amylic Alcohol. Fusel Oil = $H, C^5H^{11}O$	494
THIRD SERIES. THE VINYLATES, OR SACCHARINE COMPOUNDS	495
a. <i>The Sugars</i>	495
Cane Sugar = $C + (CH^2O)^{11}$	495
Fruit Sugar. Fructose. Vinylate = CH^2O	497
Glucose. Starch Sugar	497
Conversion of Woody Fibre into Sugar	497
Sugar of Milk	498
b. <i>The Starches and Gums</i>	498
Constitution and Properties of Starch	498
Potato Starch	499
Vegetable Albumen contained in the Potato	499
Colouring Matter in the Potato	499
Starch from Peas	500
Vegetable Casein in Peas. Legumin	500
Starch from Wheat	500
Gluten in Wheat	500
Albumen in Wheat	500
Other varieties of Starch	501
Constitution of Boiled Potatoes and Baked Bread	502

	PAGE
Chemical Substitutes for Yeast	502
British Gum. Dextrin	503
Malt	504
Diastase, and its conversion of Starch into Sugar	505
Ripening of Fruit	506
Gums. Mucilage. Vegetable Jelly	506
c. <i>Woody Fibre. Ligneous Structure</i>	507
Cellulose	507
Gun Cotton. Pyroxilin	508
Collodion	509
FOURTH SERIES. COLOURING MATTERS	510
Yellow Dyes	510
Red Dyes	511
Blue Dyes	512
Compounds of Indigo	512
Experiments with Colouring Matters	514
FIFTH SERIES. ESSENCES AND RESINS	515
Hydrocarbons	516
Oxidised Essences	517
Resins. Varnishes and Lacquers	519
Experiments with Essences and Resins	521
Organic Compounds that contain Nitrogen	523
ULTIMATE ANALYSIS OF THE ORGANIC COMPOUNDS THAT CONTAIN	
NITROGEN	523
COMPOUNDS OF CARBON AND NITROGEN	526
Cyanogen	526
Hydrocyanic Acid. Prussic Acid	527
Cyanides, single, double, and triple	529
Cyanates and Ureas	533
COMPOUNDS OF CARBON, HYDROGEN, AND NITROGEN	534
The condition, or forms of combination, in which Nitrogen is	
found in Organic Compounds	534
Aniline	535
Organic Bases. Alkaloids	536
Quinine, Morphia, Strychnine, Theine, &c.	536
FOOD, DIGESTION, AND RESPIRATION	537
Examination of an Egg	537
Milk	538
Cream and Butter	539
Casein. Cheese. Curds. Whey	540
Curdling and Fermentation of Milk	540
Constitution of Eggs and Milk	541

	PAGE
Essential Ingredients in Food	542
A. Heat-givers. Fat-formers. Supporters of Respiration.	543
B. Flesh-formers	544
Diagrams showing the Constitution of Food	544
Digestion	545
Blood. Fibrin	546
Muscular Tissue. Flesh. The Lean of Meat	546
Quantitative Composition of Beef	547
Chemical Changes effected on Meat by Cooking it	547
1. Roasting	547
2. Boiling for the sake of the Meat	547
3. Boiling for the sake of the Soup	547
4. Beef Tea	548
SKIN. GELATIN. GLUE. BONES	548
NUTRITION OF PLANTS	549
Combustion. Fuel. Illumination. Fusion	551
Inquiry into the Phenomena which attend the Burning of a Candle	552
Preparation of Coal Gas	556
Separation of the Products of the Distillation of Coal	556
Diagram of a Gas-work described	559
Flame with Illuminating Power	561
Flame without Illuminating Power	561
Combustion without Flame	562
THE USE OF COAL GAS AS A SOURCE OF HEAT IN CHEMICAL OPERATIONS	562
Various Forms of Gas Apparatus	562
Gas Apparatus for Boiling and Evaporating	563
Bunsen's Gas Apparatus for Heating Crucibles	563
Hess's Crucible Furnace	564
Paris Gas Apparatus for general Laboratory use	565
Bunsen's Regulator for Hot-air Baths, employed to heat sub- stances at any desired constant temperature	566
Griffin's Patent Blast Gas Furnace	567
Gas Burner, and separate parts of the Furnace	568
Gas Furnace heated at the top	571
Gas Furnace heated at the bottom	574
Gas Furnace with Lifting Apparatus for opening the Furnace when at a white heat	575
Examples of Fusions effected by the Gas Furnace	577
Choice and Defects of Crucibles	577
Miscellaneous Uses of the Gas Furnace	579
Muffle Furnace for Assaying and for the Roasting of Ores	578

	PAGE
Exhibition of Coloured Flames	580
SPIRIT LAMPS	580
Various Patterns of Spirit Lamps	580
Deville's Blast Turpentine Lamp	582
Deville's Blast Spirit Lamp	584
DEVILLE'S CHEMICAL FORGE	584
GLASS-BLOWING APPARATUS	587
5. Sulphur	
Characters and Properties of Sulphur	588
Experiments illustrating the Properties of Sulphur	589
OXIDES OF SULPHUR	
a. Sulphurous Acid = SO	592
Preparation of Sulphurous Acid Gas	592
Properties of Sulphurous Acid Gas	593
Preparation of Sulphites	594
b. Sulphuric Anhydride = S_2O_3	595
c. Sulpha Sulphate = S_2O_7	596
OXIDISED SULPHUR SALTS	
The Sulphates = MSO_4	597
Sulphuric Acid = HSO_4	598
Properties of Sulphuric Acid	598
Preparation of Sulphuric Acid	598
Manufacture of Oil of Vitriol in Lead Chambers	601
Distillation of Sulphuric Acid	604
Tables of the Strength of Sulphuric Acid	606
Strength and Purity of Sulphuric Acid examined	607
Heat produced by mixing Oil of Vitriol with Water	608
Use of Sulphuric Acid as a Solvent	609
Purification of Sulphuric Acid from Arsenic	610
Sulphates, Bisulphates, and Multiple Sulphates	610
Fuming Nordhausen Sulphuric Acid = $\text{SSO}_3 + 2\text{HSO}_3$	611
Pentathionates. Pentathionic Acid = HSO_5	611
Sulphites, Neutral and Acid	612
Antichlor, or Sulphite of Soda	612
Hyposulphites, Hydrated and Anhydrous	612
Hyposulphates	613
SULPHIDE OF HYDROGEN = HS	614
Preparation of Sulphide of Hydrogen Gas	614
Kipp's Apparatus for a constant supply of it.	616

	PAGE
Properties of Sulphide of Hydrogen	618
Experiments with the Gas	618
Sulphide of Hydrogen in Aqueous Solution	619
Mohr's Apparatus for a constant supply of it.	620
Sulphide of Ammonium = NH_4S	622
Metallic Sulphides	622
Precipitation of Metallic Sulphides	624
By Sulphide of Hydrogen	624
By Sulphide of Ammonium	625
Colours of the Precipitates	625, 626
Sulphide of Carbon. Xanth, CS_4	626
Experiments with Sulphide of Carbon	628
Xanthates	629
Sulphocyanides	630
6. Selenium	
Selenious Acid and the Selenites	631
Selenic Acid and the Seleniates	632
Seleniuretted Hydrogen	632
Tellurium	
7. THE TELLUROUS RADICAL = Te	632
8. THE TELLURIC RADICAL = Tec	632
9. Phosphorus	
Preparation of Phosphorus	633
Distillation and Purification of Phosphorus	634
Amorphous Phosphorus	635
Experiments illustrating the Properties of Phosphorus	635
Phosphoric Acid	639
Anhydrous Phosphoric Acid = P_2O_5	640
Hydrated Phosphoric Acid = H_3PO_3	642
The Phosphates	644
The Phosphites	645
The Hypophosphites	645
The Phosphides of Hydrogen	646
Arsenic	
10. THE ARSANOUS RADICAL = As	649
11. THE ARSANIC RADICAL = Asc	649
Arsenious Acid. White Arsenic	649
Arsenic Acid	650
Arsenites	650

	PAGE
Arseniates	651
Sulphides of Arsenic, and their Salts	652
Arseniuretted Hydrogen	652
Detection of Arsenic in Acids	653
Detection of Arsenic in Neutral Solutions	653
Reduction of Arsenic from various Salts	654
Search for Arsenic in Vegetable and Animal Mixtures	655
Reinsch's Test	655
Marsh's Test	656
Clark's Test	656
Regnault's Test	657
Cautions and Parallel Trials	658
Antimony	658
12. THE STIBOUS RADICAL = Sb	658
13. THE STIBIC RADICAL = Sbc	658
Metallic Antimony	658
Antimonious and Antimonic Salts	659
Terioxide of Antimony = Sbc,SbcO	660
Native Sulphide of Antimony = SbcS	660
Chloride of Antimony, Butter of Antimony = SbcCl	660
Tartar Emetic	660
14. Chlorine	661
Properties of Chlorine	661
Preparation of Chlorine Gas	662
Liquid Chlorine, or Solution of Chlorine	665
Experiments illustrating the Properties of Chlorine	666
Hydrochloric Acid	669
Preparation of Hydrochloric Acid Gas	669
Experiments with Hydrochloric Acid Gas	670
Aqueous Solution of Hydrochloric Acid	672
Tables of the Strength of Hydrochloric Acid	674
Qualitative Testing of Hydrochloric Acid	674
Testing of the Strength of Hydrochloric Acid	676
Hydrochloric Acid considered as a Solvent	677
Decomposition of Siliceous Minerals by Hydrochloric Acid	679
Experiments illustrating the Properties of Hydrochloric Acid	680
Chlorides	681
Reduction of Oxides and Separation of Metals by Chlorine	681
The Chlorates and Chloric Acid	682
Use of the Chlorates as Oxidising agents	683
Oxides of Chlorine	683

	PAGE
Aqua Regia, or Nitro-muriatic Acid	684
Aqua Regia considered as a Solvent	685
Chlorides of Sulphur and Phosphorus	686
Oxychloride of Phosphorus	687
15. Bromine	
Preparation of Bromine	688
Properties of Bromine	689
Hydrobromic Acid and the Bromides	690
Bromic Acid and the Bromates	691
16. Iodine	
Preparation of Iodine	691
Experiments illustrating the Properties of Iodine	692
Hydriodic Acid and the Iodides	693
Iodic Acid and the Iodates	695
Iodide of Nitrogen. Chlorides and Bromide of Iodine	695
17. Fluorine	
Hydrofluoric Acid	696
Preparation and Properties of Hydrofluoric Acid	697
Used to engrave upon Glass	697
Fluorides. Formula = MF	698
18. Boron	
Properties of Boron	698
Boric Acid, Hydrated and Anhydrous	698
Borates, Simple and Compound	699
Chloride of Boron = BCl. Fluoride of Boron = BF	699
Hydrofluoboric Acid = HB ³ F ⁴	700
19. Silicon	
Properties of Silicon	700
Silica, or Silicic Acid = Si ₂ O ₃	701
Preparation of Silica	701
Constitution of Silicates, Simple and Compound	702
Chloride of Silicon = SiCl	704
Fluoride of Silicon = SiF	705
Hydrofluosilicic Acid = HSi ² F ³	705
Silicofluorides = MSi ² F ³	707

	PAGE
Chromium	708
20. THE CHROMOUS RADICAL = Cr	708
21. THE CHROMIC RADICAL = CrC	708
The Minerals which contain Chromium	708
Properties of Metallic Chromium	708
CHROMOUS SALTS	709
Chromic Anhydride = Cr ₂ O ₃	709
Hydrated Chromic Acid = HCrO ₂	709
Preparation of Chromic Anhydride	710
Experiments illustrating the Properties of Chromic Anhydride	710
The Chromates, their Constitution and Properties	711
Chromous Chloride = CrCl	713
Oxychloride of Chromium = ClCrO	713
Terfluoride of Chromium = CrF ₂ +F	714
CHROMIC SALTS	714
Chrome Iron Ore = Cr ³ FeO ₂	714
Chromic Oxide. Green Oxide of Chromium = CrC, CrC ₂ O	714
Hydrated Oxide of Chromium = HCrC ₂ O	714
Salts of Chromic Oxide	715
Reduction of Chromic Acid to Chromic Oxide	715
Chromic Chloride = CrCl	715
22 and 23. Molybdenum	716
Metallic Ores in which Molybdenum is found	716
Molybdic Acid, its Preparation and Properties	716
Bisulphide of Molybdenum	717
24 and 25. Vanadium	717
Metallic Ores in which this Element is found	717
26. Tungstenum	718
The Metallic Ores which contain this Element	718
Tungstic Acid, Preparation and Properties	718
The Tungstates	719
Incombustible Dresses for Ladies	719
27. Titanium 720	29. Pelopium 720
28. Tantalum 720	30. Niobium 720

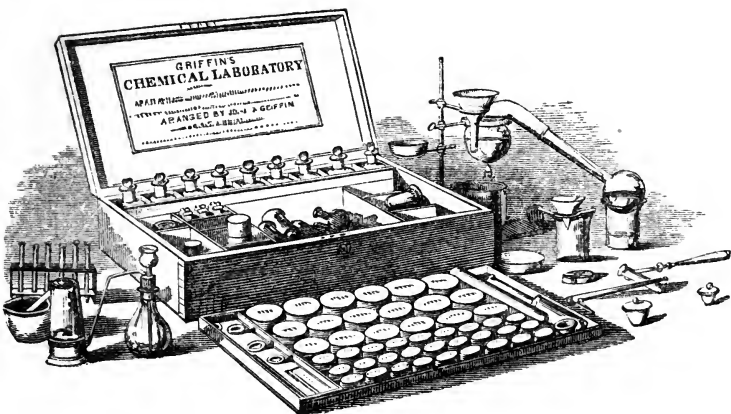

INTRODUCTION.

CHEMISTRY is the science which makes known to us the properties of the component particles of all natural bodies. It treats of the *various sorts* of substances, and of the exact determination of their differences. It exhibits the means by which the component parts of compound bodies can be separated from one another, or by which the elements of compounds can be made to combine together. In fine, it shows by what contrivances the solid particles which constitute the material substances of the world can be most beneficially applied to the service of man.

The objects of Chemistry are inexhaustible. It undertakes the examination of all bodies which act upon the senses, the solid matter of all animal, vegetable, and mineral substances. It seeks to determine the properties of those substances, the number and proportion of their component particles, the individual nature of those components, and the properties of all other compounds which can be produced by their combination. So infinitely varied are the objects of Chemistry that it is an everlasting source of occupation and amusement; and while, on this account, it receives the attention of the philosopher, it claims the notice of all men, from its utility in the arts which promote and support the comforts and existence of civilized life.

The great importance of the science of Chemistry is rendered evident by the following considerations:—It is useful in explaining natural phenomena: for in determining the constitution of the atmosphere, in investigating the changes to which it is subject, the variations

of temperature, the laws of winds, dew, rain, hail, and snow, Chemistry is our only satisfactory guide. These remarkable changes in the face of nature—changes which, because familiar, do not produce any emotion in the mind, though in themselves truly wonderful—are chemical operations on a magnificent scale, and can only be explained by chemical laws.

In man's researches into the nature of the things whence he derives the means of his comfort, his happiness, his luxuries, and even his existence—in examining the various objects which compose the mineral, the vegetable, and the animal kingdoms—Chemistry is essentially requisite for the successful progress of his inquiries.

In considering the application of Chemistry to the improvement of the arts of civilized life, a wide field of contemplation opens to our view. So extensive, indeed, are its influence and importance, that, in most of the arts, many of the processes—in some all that are employed, depend on chemical principles. The bare mention of some of these arts will suggest ample illustrations of its extensive utility.

In the medical art, so great is the service of a knowledge of Chemistry, that its practical acquisition is now universally regarded as an essential branch of a medical education. In agriculture, recent chemical researches have established principles that promise to be followed by results of extraordinary benefit to mankind. In the art of extracting metals from their ores, in purifying and combining them with each other, and in forming instruments and metals—whether for useful or ornamental purposes—almost all the processes are purely chemical. The arts of glass and porcelain making, of tanning, soap-making, dyeing, and bleaching, depend entirely upon Chemistry; and all the processes in baking, brewing, and distilling, most of the culinary arts, and many other processes in domestic economy, are chemical operations. In short, wherever, in any of the processes of nature or of art, the accumulation or the diminution of heat takes place—wherever a sensible change is to be effected by heat—wherever substances in combination are to be separated—wherever the union of simple substances and the formation of new compounds are to be effected—the operations and their results can only be explained on chemical principles.

From this general view of the extensive applications of chemical science to the arts, those who have not considered the objects which it embraces will be enabled to judge of the importance of this study.

REASONS WHY CHEMISTRY SHOULD BECOME A STATED BRANCH OF EDUCATION.—If we consider Chemistry purely as a science, we shall find no subject better calculated to encourage that generous love of truth which confers dignity and superiority on those who successfully pursue it. There is no science which holds out more interesting subjects of research, and none which affords more striking proofs of the wisdom and beneficence of the Creator of the universe.

A machine constructed by human art, is admired in proportion to the simplicity of its contrivance, to the extent of its usefulness, and to the niceness of its adaptations. But the works of man sink into nothing when brought into comparison with the works of nature. When we examine the former, every step of our progress is obscured with comparative clumsiness and defect: in contemplating the latter, we behold perfection rise on perfection, and more exquisite wonders still meeting our view. It is the merit of Chemistry, that by its aid we are enabled to take a minuter survey of the great system of the universe. And we find, so far as our limited powers can comprehend it, that the whole is nicely balanced and adjusted, and that all its changes tend to the most beneficial purposes. Circumstances which, on a superficial view, were seeming imperfections and defects, a closer inspection points out to be real excellencies. In all the singular and surprising changes which everywhere present themselves, the more closely we observe and examine them, the more do we admire the simple means by which they are accomplished, and the intelligent design and perfect wisdom displayed in the beneficial ends to which they are directed.

To these considerations respecting the importance of Chemistry, we may add another, which, at a period when this science is taking its proper place in schools as a branch of general education, is not without its interest. This consideration is, that Chemistry is a subject qualified to train both the *mind* and the *hands* of young people to habits of industry, regularity, and order. It teaches the doctrine that accurate and extensive observation is necessary for the accumulation of facts; that careful and exact comparison is necessary for the reduction of these facts to general statements; that logical precision is necessary in estimating the relative value of various problematical statements on points where positive information is wanting; that, consequently, the chemist must study to become capable of judging according to *circumstantial evidence*, and in that manner habituate himself to the formation of sound opinions on all subjects that come under his cognizance. If any one will consider the great value of a sound judgment in the ordinary affairs of life, he cannot but appreciate the strength of this argument in favour of a chemical education.

Again, the necessity of observing the most scrupulous and constant regard to *cleanliness* in experimenting, as being indispensable to success, must gradually induce habits of neatness and cleanliness even in the most slovenly; while the equally unavoidable necessity of carrying on the different steps of an operation in an orderly and cautious manner, must have a corresponding moral influence upon persons of the most careless disposition.

Independently, therefore, of any advantages to be hoped for from the possession of the mere facts of Chemistry, setting entirely out of view the applications, either of the principles or the details of the science to

the prospective commercial, or scientific, pursuits of the young student, there is, in the mental and moral discipline which its study affords, high inducements for making Chemistry a branch of general education.

METHODS OF CHEMICAL RESEARCH.—It has been demonstrated by the experiments of chemists, that the marvellous diversity of appearance under which bodies are presented to the eye, and the unceasing changes to which they are subject, are occasioned by the mutual reactions of a small number of unchangeable elementary particles. The distinctive properties of these particles, the nature of the phenomena which mark their reactions, the methods of causing them to combine, the properties of the resulting compounds, and the methods of decomposing these compounds,—are, consequently, the objects which the chemical student is called upon to investigate.

There are two methods of proceeding in the acquisition of chemical knowledge; these are called *analysis* and *synthesis*. ANALYSIS means the art of *separating* the constituents of compound bodies,—SYNTHESIS, the art of forming compounds, by the *putting together*, or effecting the *combination*, of their component particles. Both analysis and synthesis are practically effected by the performing of certain processes or operations, thence called *chemical operations*.

The properties of natural bodies, whether they be simple or compound, native or factitious, can never be determined *à priori*; they can be discovered only by *actual trial*. When an unknown substance is presented to a chemist for examination, he submits it to certain *trials*, or performs certain *operations* upon it. He examines, for example, the relation of the unknown body to heat, light, water, acids, alcalies, and other liquids. These *trials* have particular *names* given to them, for the sake of convenience in the communication of knowledge. If a substance is exposed to a *red heat*, the operation is termed IGNITION. If the substance *melts*, the operation is termed FUSION. If the substance, on being put into water, *dissolves* or *disappears*, the operation is termed SOLUTION, and the resulting liquid is called a *solution*. If the solution is exposed to heat so as to cause the water to rise *in vapour*, the operation is termed EVAPORATION; or if the operation is so performed that the vapour is collected and reconverted into water, the operation is termed DISTILLATION. If, on the contrary, the solution, instead of being exposed to evaporation, is mixed with some liquid which causes the production of a *solid substance* or powder, the operation is called PRECIPITATION; and if means be taken to separate the solid powder from the residual liquid, by straining through a porous substance, this operation is termed FILTRATION.

The performance of these operations communicates to the chemist a certain degree of knowledge respecting the properties of the substance operated upon. If the substance does not melt when exposed to a strong degree of heat, it is said to be *infusible*. If it does not dissolve

when placed in a liquid, it is said to be *insoluble*. A description of the results of a series of such experiments, is the chemical character of the substance. We cannot account for the properties thus found to belong to a substance. No chemist can go farther than the ascertainment of simple facts. The sagacity of man is insufficient to determine WHY a given substance is soluble or insoluble, fusible or infusible. The *nature of the power* which causes fusion or solubility is unknown. And, indeed, this is the case with regard to all physical phenomena: *the forces which produce them are unknown to man, except by their effects.*

The more numerous the operations performed upon a substance, the more accurate is the knowledge acquired respecting its properties: provided the operations be suitably conducted. The properties of a substance can never be wholly known. Chemists begin with a single fact; their daily experience enlarges their knowledge: but, at the best, their acquaintance with the properties of any one body is but limited and imperfect. Not until a substance shall have been submitted to the action of every other substance, and under all possible variations of temperature, pressure, and so forth, will its properties be wholly determined; and that will *never be*. The knowledge we possess respecting the properties of known elements and their compounds, is, notwithstanding the labours of many industrious chemists, still extremely imperfect. No practical chemist, however young he may be in the science, can pursue his studies with even a moderate degree of zeal, without being enabled to add something almost daily to the existing stock of intelligence. The variety of unrecorded facts which continually strike the eye of an industrious experimenter, is indeed surprising.

The first business of a young chemist is to make himself acquainted with what is already known, with what has been already determined by the experiments of others. His next concern will be to learn something which no one else has yet discovered.

Chemistry is a science founded so entirely upon experiment that no person can understand it fully unless he personally performs such experiments as verify its fundamental truths. The hearing of lectures, and the reading of books, will never benefit him who attends to nothing else; for Chemistry can alone be studied to advantage *practically*. *One Experiment*, well conducted, and carefully observed by the student, from first to last, will afford more knowledge than the mere perusal of a whole volume.

DIFFERENT CLASSES OF EXPERIMENTS.—Chemical experiments may be divided, for convenience, into three sorts; namely, Determinative, Demonstrative, and Productive.

(a.) *Determinative Experiments* (Experiments of *Research*).—If anybody brings me a substance, and desires to know the nature of it, I must make a *determinative experiment*; in other words, I must submit it to analysis, or *determine by experiment*, what it is composed of.

Chemical analysis is of two sorts, qualitative and quantitative. A qualitative analysis makes known the chemical nature of the constituents of a compound, but not the relative quantities of those constituents. A quantitative analysis makes known both the nature of the constituents and the exact quantity of each by weight. Experiments of this sort are also called experiments of *research*. No man can execute an analysis without previously acquiring a considerable share of chemical information. Before a qualitative analysis can be executed, it is necessary to become acquainted with the properties of all the known elements and their principal compounds, as well as with the methods of determining whether any of them, on a certain occasion, are present or absent. The use of chemical *tests* or *re-agents*, depends upon the knowledge previously acquired, that particular bodies, in particular circumstances, act in a determinate manner. There is, for example, a liquid called oil of vitriol. I know that other liquids which contain certain substances in solution, upon being mixed with oil of vitriol, produce a precipitate. If, then, upon dissolving an unknown substance in water, and mixing the solution with oil of vitriol, I obtain no precipitate, I am certified that the substances alluded to are not present. It is evident, that unless I know beforehand what substances *do* give a precipitate with oil of vitriol, and what substances *do not*, it is useless to apply the test: because, whether I see a precipitate or not, I acquire no information. A vast number of other substances serve, as well as oil of vitriol, the office of chemical tests, and their employment in chemical analysis constitutes a very important part of chemical study. In the subsequent pages, the reader will frequently find it stated by what diversity of tests a particular substance may be known to be present, and also for what other substances any given compound is qualified to act as a test.

In quantitative analysis something more has to be done. Supposing a chemist to know how to detect all the ingredients of a compound, supposing that he has detected them, he has, in quantitative analysis, the additional task of separating these ingredients from one another, of freeing them from every possible intermixture, and of determining their respective weights. In some cases, two substances can be separated from each other with ease; in other cases, the separation cannot be effected without great difficulty. The methods of separation depend altogether upon the properties of the particular substances which are to be separated, and can only be learned by studying those properties. But success also depends upon the skill of the chemist in the performance of the numerous operations which occur in analysis. The fusions, solutions, filtrations, and evaporations, require to be performed with extreme care. If a drop of liquid falls down, or an atom of powder is blown away, the whole experiment is spoiled, and the labour, probably of weeks, is frustrated. To perform an analysis with accuracy should be the object of a student's ambition; but if he wishes to attain

that object, he must not only industriously study the properties of chemical bodies, but continually accustom himself to manipulation, that he may become dexterous in the performance of those operations upon which the success of an analysis mainly depends.

(b.) *Demonstrative Experiments* are of a different kind. They are employed in the *communication* of chemical knowledge. When a chemist has discovered anything new, he announces the discovery, and describes an experiment by which the truth of his statement can be proved. This is a demonstrative experiment. There are certain substances which, if heated at one end, very soon become hot at the other end; these are said to be *good conductors of heat*. There are other substances which, on being heated at one end, are a long time before they become hot at the other end; such substances are called *bad conductors of heat*. In general the metals are good conductors of heat, but the metal called platinum is a bad conductor of heat. The proof of this is easy. You take a short wire of platinum, hold it by the fingers at one end and place the other end in the flame of a spirit-lamp. You find that the heat comes to the fingers very slowly. This is a demonstrative experiment. As the students of a science must be supposed to be quite ignorant of its facts, it is the business of teachers to demonstrate the truth of their assertions by experiments, and accordingly lecturers on Chemistry commonly exhibit a great number of experiments. It would be in vain, however, to attempt, in a class, to demonstrate everything. Want of time forbids it. But a teacher should be careful not to state that as a *chemical fact*, which is *incapable of proof* by a *chemical experiment*.

(c.) *Productive Experiments*.—I have given this name to those experiments which have for object the *production* of chemical substances. The *Pharmacopœia* is a collection of productive experiments, containing instructions for preparing or producing the chemical substances employed in medicine. It will be understood, of course, that many analytical and demonstrative experiments are also productive experiments; but I understand by the latter term, those experiments only which are made for the express purpose of producing chemical preparations in quantities for use. Productive experiments on the small scale form an admirable exercise for young students. The preparation of the various acids, oxides, salts, sulphides, chlorides, iodides, &c., is capable of furnishing most useful information respecting the properties of those substances, and has the further beneficial effect of habituating the student to careful manipulation. A vast number of substances can be prepared in the small way with great facility, with the help of glass tubes, small flasks, capsules, glass plates, &c., in sufficient quantities to enable the operator to ascertain their properties and reactions with other substances. A student's spare time cannot be more agreeably or usefully occupied than in preparing and examining compounds not previously familiar to him

Portions of substances so prepared may be preserved in small glass tubes closed with corks. Productive experiments in the large way are those which produce the metals, salts, acids, alcalies, and other commodities of the druggist, the drysalter, the colour-maker, &c.

MICRO-CHEMICAL EXPERIMENTS.—The chemical properties of a substance characterise equally the smallest portion of that substance, or the greatest mass. That which can be demonstrated with a pound, can often be demonstrated with a grain. Hence, chemical experiments may be performed, either with large portions of matter, or with small portions; and whether in any case a large or small portion should be operated upon, is a thing to be determined solely by expediency. In trade, where productive experiments are made with a view to obtain preparations for sale, the quantities operated upon are often extremely large, amounting to thousands of tons. In analysis, the quantity of a body submitted to a test weighs sometimes but the fraction of a grain. When a lecturer has to teach Chemistry to a large audience, he is obliged to make his demonstrative experiments upon a large scale, otherwise a majority of the persons present may not be able to perceive what takes place. And whenever a theory is built upon a single experiment, the lecturer should take particular care to make this experiment in such a manner that every person present may see and comprehend it fully; for if the demonstration is not made to *tell*, the theory sinks unheeded, and the arguments grounded upon it are worthless. I give this hint to the members of Mechanics' Institutions, who have lately adopted the useful practice of lecturing to one another.

As the demonstrative experiments of the lecture-room are unavoidably scanty and unsatisfactory, the student who desires to know somewhat more of the science than he can learn there, must necessarily pursue his studies in the laboratory, either at home or in public. It is indispensably necessary, that he perform with his own hands the fundamental experiments of chemistry, in the best manner that his time, his apparatus, and his means admit. He will find it of importance, in this case, to operate upon extremely small portions of matter; for he will then not only save time and money, but often be enabled to perform a successful experiment, when, by operating upon a large mass, he would as certainly fail. The preparation of the gases, the formation and crystallisation of salts, the application of tests, and a thousand other entertaining and instructive experiments, can all be performed by the student, better on a small scale than in the large way; nay more, a student in his closet very frequently succeeds in performing an experiment which fails on the lecture-table of the professor; because the hurry and business of a lecture-room, produce unavoidable accidents. This, therefore, is a circumstance of which the chemical student should be prepared to take every advantage. The faculty of experimenting with accuracy, facility, and economy, ought to be gained as speedily

as possible; for it is upon that faculty that the progress of the young chemist is principally dependent.

DIFFERENT SORTS OF CHEMICAL SUBSTANCES.—All natural bodies are either *simple* or *compound*. Those substances are SIMPLE, which cannot, by any known method, be separated, decomposed, or divided, in such a manner as to produce particles different in their properties from one another, or from the original substances. On the other hand, those substances are COMPOUND, which experiment is capable of resolving into particles of an unlike nature. For a period of many centuries, and even till a very late date, there were four substances held to be simple or elementary. These were fire, air, earth, and water. Of these four bodies, all others were supposed to be constituted, though nobody could ever prove, or indeed ever tried to prove, that this was the case. The system, however, continued to be orthodox until very lately, when three of these imaginary *elements*, namely, air, water, and earth, were proved to be compounds. But with respect to fire, it is still unknown whether it be simple or compound, or in what its essence consists, or by what causes its effects are produced. What the ancients considered to be simple bodies are no longer considered to be simple; but in place of these substances, the chemists of modern times have elevated to the dignity of elements a far more numerous race. No one, however, dogmatically asserts now-a-days that the substances termed elements are absolutely of a simple nature. The term element intimates no more than that the body to which it is applied, has never, in the opinion of modern chemists, been subjected to decomposition—that it has never been divided into particles different from one another, or from the original substance.

CHEMICAL ELEMENTS.—According to the present views of chemists, there are *sixty-one* ELEMENTS, or *simple substances*; that is to say, sixty-one substances which individually differ in properties from every other substance, and which, by their various combinations, produce the diversified compounds that constitute the material world,—animal, vegetable, and mineral. The names of these sixty-one elements are contained in the following list. I have added a few notes, to give the reader an idea of the relative importance and abundance of these elements, the state in which they exist in nature, and their classification into such as concern animal and vegetable substances, and such as do not. The properties of these elements, and the experiments which serve to separate them from other substances, and by which the separate identity of each is demonstrated, will be described in a subsequent part of this work.

1. OXYGEN.

2. HYDROGEN.

3. NITROGEN.

4. CARBON.

These four elements are of extreme importance, and exist in great abundance. Oxygen and hydrogen are the sole constituents of WATER.

Oxygen and nitrogen are the main constituents of **ATMOSPHERIC AIR**. Hydrogen and nitrogen constitute **AMMONIA**, which is formed in large quantities during the putrefaction and decomposition of animal and vegetable substances, ascends into the atmosphere, and, after thunderstorms, again falls to the earth, dissolved in rain. Oxygen and carbon constitute **CARBONIC ACID**, which always exists in atmospheric air. It is from these substances that **VEGETABLES** are derived. The ammonia and carbonic acid are carried down by rain-water into the *soil*, or pulverulent surface of the earth. The seeds and roots of plants decompose these compounds, and absorb their carbon, hydrogen, oxygen, and nitrogen; and the power of vegetation *organises* and converts them into new compounds, such as did not previously exist. These new vegetable substances consist for the greater part of carbon, hydrogen, and oxygen, and some of them of carbon, hydrogen, oxygen, and nitrogen. They serve afterwards as the food of **ANIMALS**, those which contain nitrogen being the most nutritious. The process of *digestion* converts the vegetable substances into animal substances, often with very slight change in chemical constitution, sometimes with none at all; the process of digestion in such cases consisting of a mere *solution* of the substances operated upon. When animals *die*, their component substances suffer decomposition, and reproduce their original constituents—water, ammonia, and carbonic acid—oxygen, hydrogen, nitrogen, and carbon. There is a constant circulation of the organic elements. Plants derive their means of nutriment from the air; animals from plants; and when the animals die, their components return to the atmosphere, to supply another generation of plants and of animals. These are mighty and wonderful transmutations, such as fill the mind with admiration and astonishment.

The various other compounds that are produced by the combination of these four elements with one another, are too numerous to be mentioned in this list. I will name only a few of them:—Oxygen, hydrogen, and nitrogen, produce liquid nitric acid. Oxygen, hydrogen, and carbon, produce oxalic acid, citric acid (lemon-juice), and vinegar. Hydrogen and carbon produce the gas that is employed in gas-lighting. Hydrogen, nitrogen, and carbon, produce prussic acid.

Carbon is found in nature pure in the diamond; nearly pure in graphite; and very abundantly in combination with hydrogen as coal.

5.—SILICON.

This element in combination with oxygen forms sand, flint, quartz, siliceous earth—and is one of the most abundant substances in nature. In combination with oxygen and potassium, forming silicate of potash, it enters into the constitution of straw (wheat-straw, cane, &c.)

6.—ALUMINIUM.

In combination with oxygen this element forms clay, or aluminous earth. It also forms part of many minerals, sometimes combined only with oxygen, more frequently with the addition of silicon. Though so useful in promoting the growth of plants, it enters but rarely and in small proportion into their composition, and never forms a constituent of animal substances.

7.—CALCIUM.

In combination with oxygen, this element forms lime or calcareous earth. In combination with oxygen and carbon it forms chalk, marble, calcareous spar, and the numerous varieties of limestone. This element enters into the composition of many plants, and of certain parts of all animals, particularly their shells and bones.

The last three elements, in combination with oxygen, and mixed with one another, form the main portions of all the different kinds of *soils* and *rocks*, siliceous, aluminous, and calcareous. All other elements that occur in soils, exist in much smaller quantities than these, though some of them are yet more indispensable than they are, to promote the general growth, or the production of particular parts, of plants.

8.—CHLORINE.—9. SODIUM.

These two elements constitute the compound called sea salt or kitchen salt, a white substance used to season food, to preserve animal substances from putrefaction, and often also as a manure to promote the growth of plants. It is the chief saline matter of sea water, and it also exists in the state of a mineral.

The chlorine in combination with hydrogen forms muriatic acid, or spirits of salts; in combination with hydrogen and nitrogen it forms the salt called sal-ammoniac.

The sodium in combination with carbon and oxygen forms the detergent commonly called *soda*, or chemically, carbonate of soda. Sodium exists in a great number of plants, and chloride of sodium is found in many animal substances.

10.—POTASSIUM.

This element is a constituent of the mineral felspar, and therefore one of the components of the granitic rocks, which form the great mass of the earth. It is indispensable for the growth of many plants. The wood of all trees contains it; and no tree can flourish in a soil which is without potassium. When wood is burnt, and the ashes washed, a salt is obtained which is termed potash, or pearl ash. This consists of potassium, oxygen, and carbon. The juice of the plant called *sorrel*,

contains a salt termed oxalate of potash. This consists of potassium, oxygen, and carbon, and hence this plant cannot grow in a soil which is free from potassium. The stems and leaves of the gramineæ contain silicate of potash, which consists of the elements silicon, oxygen, and potassium. In general, soils derive this element from the decomposition of felspar, or of other stones that contain it; but of late, it has been added artificially, by using as a manure the salt called nitrate of potash (saltpetre), which is a compound of oxygen, nitrogen, and potassium. This salt renders soils very fertile, because it adds to them two substances, both of which are highly beneficial to plants, namely, nitrogen and potassium.

11.—SULPHUR (*Brimstone*).

In many parts of the world, as near Paris, in Derbyshire, &c., there are found large masses of a mineral called alabaster, gypsum, selenite, sulphate of lime, plaster of Paris, &c. This mineral consists of oxygen, calcium, and sulphur. The same substance is found dispersed in many soils, dissolved in most springs, rivers, and seas, and forming a limited part of many plants. Sulphur occurs in a free state near volcanoes, and in combination with many metals, in the ores termed pyrites. Thus, the very abundant golden-looking mineral called in Scotland slate diamonds, or iron pyrites, consists of sulphur in combination with iron. Sulphur combined with oxygen and hydrogen form the strong acid termed oil of vitriol, or sulphuric acid. It is a constituent, in small proportions, of many of those vegetable productions, which, in consequence of their containing nitrogen, afford nutritious food, namely, the substances called fibrin, albumen, casein, and gluten. It is very often present in small quantities in animal substances. It is a constituent of horn and of hair, and it is always present in eggs. The peculiar odour of rotten eggs is due to a compound containing sulphur and hydrogen.

12.—PHOSPHORUS.

A few minerals are found that contain a considerable quantity of this element. Thus, phosphate of lead, found at Leadhills, contains oxygen, phosphorus, and lead. Apatite contains oxygen, calcium, chlorine, and phosphorus. In very many other minerals, a small proportion of this element occurs; so much so, that phosphorus occurs in most soils, and, in some state of combination, as phosphate of lime, phosphate of magnesia, &c., in many vegetables. From vegetables it passes into animals, of which probably none can live without phosphorus, since it not only exists in their liquid or soft parts, but is indispensable for the bones of the vertebrated animals, and the shells of the crustaceous. The earthy matter of bones consists chiefly of the elements phosphorus, calcium, and oxygen; and shells commonly contain the same elements, with the addition of carbon. This is the reason why ground bones and

shells form an excellent manure for soils. The odour of decaying fish is probably due to the presence of a compound containing phosphorus.

13.—MAGNESIUM.

This element exists in abundance in the mineral called magnesian limestone, pretty largely in many rarer minerals, in small quantity in a great number of other minerals, and as a constant constituent of the saline matter of the ocean. From these sources it finds its way into most soils, thence, in small proportions, into many plants, and from them into animals. It is a constituent of blood and of bones. In the state of phosphate of magnesia and ammonia, it is found in the seeds of the gramineæ; and the potato contains a considerable quantity of phosphate of magnesia. It is an element, the knowledge of which is important to the agriculturist, as it appears to be often injurious to vegetation; yet, for the reason given above, it greatly promotes the growth of the potato plant. It is well known in medicine, for, in combination with oxygen and sulphur, it forms the bitter purgative substance called Epsom salt, or sulphate of magnesia, and, in combination with oxygen alone, the earth termed magnesia.

14.—IRON.

The most abundant and the most widely-diffused of all the metallic substances. It occurs in combination with oxygen as ochre, ironstone, &c.; with sulphur as pyrites; with carbon and oxygen as carbonate of iron, and this in combination with clay as clay-ironstone, a mineral of great abundance and importance in England and Scotland. It occurs, also, in many other forms of combination, too numerous to detail. It is the ordinary colouring matter of earths and soils. In minute quantities, it enters into all vegetables and animals. It is a constituent of the blood.

15.—MANGANESE.

This element, combined with oxygen, produces a black substance termed peroxide of manganese, a mineral which occurs in large quantities. Manganese forms many others minerals, and occurs in small quantities as the colouring matter of many more. It is found in plants in very small quantities, and but rarely in animals.

16.—IODINE.

Exists in sea-water, and enters into the composition of sea-weeds, sponges, &c.

17.—FLUORINE.

Known chiefly as a component of the mineral called Fluorspar, in which it is combined with calcium. It occurs in some other minerals, and has been found in the bones of animals.

The foregoing elements all enter into the composition of plants, and most of them into the composition of animals. In contradistinction to the *organic* elements, namely, the four elements, oxygen, hydrogen, carbon, and nitrogen, the others, from No. 5 to No. 17, are termed the *inorganic*, or mineral constituents of plants. These inorganic elements occur in plants in very small proportions relatively to the proportions of the organic elements; yet they are not less essential than the latter to the development and growth of the plants, so much so, that soils in which particular mineral constituents do not exist, are absolutely sterile in regard to the vegetation of plants which require these particular constituents, notwithstanding the presence of any excess of organic manure.

The following elements belong exclusively to inorganic nature. They form no part of plants or animals, nor are they useful in promoting the growth of either class of organized bodies.

- | | | | |
|-----------------|---|--|---|
| 18. GOLD. | 23. ZINC. | } Well-known common metals, which occur in pretty considerable quantities. | |
| 19. SILVER. | 24. MERCURY. | | |
| 20. COPPER. | 25. ANTIMONY. | | |
| 21. LEAD. | 26. ARSENIC. | | |
| 22. TIN. | 27. PLATINUM. | | |
| 28. BISMUTH. | 38. TELLURIUM. | | } Metals,—rarer, less known, and less used than the foregoing. Those which are most abundant and most used are the first seven in the list. |
| 29. COBALT. | 39. PELOPIUM. | | |
| 30. NICKEL. | 40. NIOBIUM. | | |
| 31. CHROMIUM. | 41. TANTALIUM. | | |
| 32. PALLADIUM. | 42. TITANIUM. | | |
| 33. CADMIUM. | 43. OSMIUM. | | |
| 34. MOLYBDENUM. | 44. RHODIUM. | | |
| 35. URANIUM. | 45. IRIDIUM. | | |
| 36. VANADIUM. | 46. RUTHENIUM. | | |
| 37. TUNGSTEN. | | | |
| 47. CERIUM. | 52. THORIUM. | } Metallic bases of rare earths, seldom separated from their ores, and when separated applied to no use. | |
| 48. TERBIUM. | 53. ZIRCONIUM. | | |
| 49. ERBIUM. | 54. YTTRIUM. | | |
| 50. DIDYMIUM. | 55. GLUCINUM. | | |
| 51. LANTANIUM. | | | |
| 56. STRONTIUM. | } Metallic bases of alkaline earths. Barium occurs plentifully in the mineral called Heavy Spar. It is chiefly used in chemical experiments. Lithium is extremely rare. | | |
| 57. BARIUM. | | | |
| 58. LITHIUM. | | | |
| 59. BORON. | The base of the boracic acid. | | |
| 60. SELENIUM. | Rare : resembles sulphur in many of its properties. | | |
| 61. BROMINE. | Resembles chlorine in many of its properties. Is employed in the arts to a certain extent. Occurs in sea-water, and in some salt springs. | | |

THE CAUSE OF CHEMICAL COMBINATION.—When the elementary bodies are placed in contact under particular circumstances, they unite or combine together, and produce compound bodies. Some combinations are effected very readily, and some with great difficulty, and there are certain elements which can scarcely by any means be made to combine. The compounds produced by the combination of the elements, possess properties very different from those of the elements of which they are composed. The POWER, in virtue of which simple bodies can combine and produce compounds, is one of which the nature is totally unknown to man. Chemists have learned no more than that simple bodies, or bodies supposed to be simple, DO COMBINE; but WHY *they combine*, or *what it is* which MAKES THEM *combine*, they have not discovered.

It is sometimes stated that certain bodies combine with one another, because they have an *affinity* for one another, and that these bodies which do not combine together have no affinity for each other; and it is thence argued that *chemical affinity* is the *cause* of combination.

Now, it is convenient to have a *term* to denote that kind of attraction which binds together the elements of a chemical compound, as distinguished from that physical attraction which makes the particles of all bodies cohere. Using the word *cohesion* to denote this latter quality, we may use the word *affinity* to signify the former. But we must bear in mind, that by so doing, we merely give a *name* to a phenomenon, not an *explanation* of it.

VARIETIES OF COMPOUNDS.—*Acids, Bases, Salts, &c.* The Chemical Elements are classed into two groups, the METALS and the METALLOIDS. The line of demarcation is not very distinct, but the following elements are commonly called metalloids:—

1. Oxygen.	7. Chlorine.	13. Silicon.
2. Hydrogen.	8. Bromine.	To which some
3. Nitrogen.	9. Iodine.	chemists add
4. Sulphur.	10. Fluorine.	14. Arsenic.
5. Selenium.	11. Carbon.	15. Tellur m.
6. Phosphorus.	12. Boron.	

The residue of the elements belong to the group of metals.

Oxygen, in combining with another element, produces an *oxide*. When this combination occurs with a metalloid, the compound is an *acid*; when it occurs with a metal, it is commonly a *base*; and the acids and bases thus produced combine with one another to form *salts*. Thus the salt called sulphate of soda, is held by the prevalent theory of chemistry to contain sulphuric acid and soda. The sulphuric acid is composed of oxygen and sulphur (a metalloid), and the soda of oxygen and sodium (a metal).

There is, however, another class of salts, which are produced by direct

combination between the metals and some of the metalloids, without the incorporation of oxygen. Thus, kitchen salt is a compound of chlorine and sodium; fluorspar is a compound of calcium and chlorine; and iron pyrites is a compound of iron and sulphur. The chemical names of these compounds are chloride of sodium, fluoride of calcium, and sulphide of iron.

The compounds produced by hydrogen are very variable in their characters: with oxygen it forms the mild compound we call water; with chlorine it forms muriatic acid; with nitrogen it forms the alcali ammonia; with oxygen and metalloids together it produces strong acids, as nitric acid and sulphuric acid; with oxygen and metals together it produces alcalies, as caustic potash, caustic soda, and slaked lime. These explanations are given in a general sense. There are many exceptions to these rules. It is impossible to describe in a few sentences the diversified actions of the chemical elements.

THE CAUSE OF CHEMICAL DECOMPOSITION.—When chemical compounds are strongly electrified, they suffer decomposition, and the liberated atoms of their constituents appear, partly at the positive pole, and partly at the negative pole, of the electric apparatus. Those which appear at the positive pole are denominated *electro-negative* elements, and those which appear at the other pole, *electro-positive* elements. It is found that every element is *negative* towards a portion of the elements, and *positive* towards the rest.

The manifestation of electrical appearances at the moment when an act of combination or decomposition is effected, throws no light upon the nature of the force which makes the elements combine. We see nothing more than the phenomena by which the acts of combination and decomposition are attended.

When a number of chemical elements are set at liberty in juxtaposition, those combinations take place, which produce such compounds as can best exist *under the circumstances* in which the occurrence is brought to pass. The same elements brought together at a *low* temperature, at a *medium* temperature, and at a *high* temperature, produce different compounds, *i. e.*, they produce such compounds as can best exist *under the circumstances* of the trial.

If a compound, consisting of a powerful electro-negative element and of an indifferent element, *i. e.*, of one possessing no very marked electrical powers, be brought into contact with a powerful electro-positive element, decomposition is immediately effected, and those two elements which exhibit the antagonistic electricities most strikingly, combine, to the exclusion of the other. The VERY NEUTRAL compound produced by the combination of an *electro-positive* with an *electro-negative* element, can better exist in presence of an *indifferent* element, than the SEMI-NEUTRAL compound composed of an *indifferent* in combination with an *electro-negative*, can exist in presence of an *electro-positive*. In the one

case, the electrical power is partially at rest; in the other, its dispersive influence is in full operation.

When compounds are placed in juxtaposition, in a state fitted for chemical action, as, for example, in solution of water, they are observed to *decompose each other*, PROVIDED that, by doing so, they can give origin to other compounds, more capable than the original compounds of emerging from the sphere of each other's action; OTHERWISE, they *do not decompose each other*. If, for example, we put together two soluble salts, of such a nature as to give rise, by an interchange of their antagonistic electrical elements, that is to say, of their *acids* and *bases*, to two other salts of the same degree of solubility, then no decomposition takes place. But if, on the other hand, we place together two salts of such a nature, that the interchange of their antagonistic electrical elements can produce a salt of less solubility than the original salts, then decomposition is effected,—let the insolubility of the new salt result from its tendency to assume either the solid form or the gaseous.

Hence we draw a rule useful in practice:—*Two saline compounds in solution being given, if the base of the one can produce, with the acid of the other, a compound insoluble in the water of the given solutions, then, upon mixing the solutions, precipitation will occur.*

For example, the compound called sulphate of barytes is insoluble in aqueous solutions of the sulphates and chlorides. If, therefore, we mix a solution of *chloride of barium* with a solution of *sulphate of soda*, the sulphur and oxygen of the latter combine with the barium of the former, and precipitate in the state of *sulphate of barytes*—leaving *chloride of sodium* in the supernatant solution.

A mixture of borate of soda and sulphuric acid produces, *at a red heat*, borate of soda and sulphuric acid; but at the *heat of boiling water* and in solution it produces sulphate of soda and boracic acid. In the first case, the sulphuric acid separates by volatilization; in the second case, the boracic acid separates by precipitation. Thus the proximate constituents afforded by the decomposition of compounds are different under different circumstances of decomposition. If the two original compounds, and the two compounds capable of being produced by the interchange of their antagonistic electric elements, were all equally fixed in the fire, and equally soluble in water, there would be no decomposition.

Vain, therefore, is the attempt to effect double decomposition, excepting where it can produce new compounds, self-empowered to get readily out of each other's vicinity; but when this is provided for, decompositions are readily and constantly effected. Whenever we desire to know, whether or not there will be a precipitate produced when two given saline solutions are mixed together, we do not require to look at what have been termed *tables of affinity*, we only need to examine whether the two given soluble salts can, by exchanging their acids and bases, produce an insoluble salt. If they can, then there will certainly be a precipitate produced when the solutions are mixed together.

CHEMICAL EQUIVALENTS.

THE following Table exhibits the chemical equivalents or combining proportions of all the Elementary Substances and of many important compounds, with the arrangement of symbolic formulæ which indicate the presumed composition of the compounds. The theory of chemical combination will be examined in a subsequent section, in which also the laws respecting symbols and formulæ will be explained. In the meantime, this table is given to supply the reader with a mass of useful facts, to which it will frequently be necessary to refer.

In making Experiments with the substances named in this table, those proportions are to be taken by weight which are quoted in this table; attention being duly paid to those compounds in which elements occur in double equivalents, and which possess a twofold power of saturation. Thus, one equivalent of caustic potash KHO , weighing 56, neutralises one equivalent of hydrochloric acid HCl , weighing 36.5, producing one equivalent of chloride of potassium KCl , weighing 74.5, and one of water H_2O , weighing 18. But one equivalent of carbonate of potash K_2CO_3 , weighing 138, neutralises two equivalents of hydrochloric acid $\text{HCl} + \text{HCl}$, weighing 73, and produces two equivalents of chloride of potassium $\text{KCl} + \text{KCl}$, weighing 149, one equivalent of water H_2O , weighing 18, and one equivalent of carbonic acid, weighing 44. The carbonates all possess this double saturating power, and are said to be *Bibasic*.

The weights, given in the table, are all *relative* one to another. They may be grains, or pounds, or tons. What *absolute quantities* of substances are to be used in any given operation, depends upon the *object* for which the operation is performed. In another section of this work, where I describe the preparation of Equivalent Test Liquors, it is recommended that when the *Equivalent* of any substance is *taken in English Grains*, it shall be called a TEST ATOM. By this means, the *relative* quantities which are represented by the numbers in the table, are, for experimental purposes, converted into *absolute* quantities.

The names that are given in the following list are, generally, those by which the respective substances are usually designated; but the formulæ which represent their composition are written in accordance with the "Radical Theory," which theory is developed in a subsequent section. It follows, as a consequence of the transitional state in which theoretical chemistry is now placed, that these names and formulæ sometimes convey different theoretical opinions.

The reconciliation of these differences will be attempted in subsequent discussions on special points of theory.

The Formulæ and Equivalents of Gaseous Substances are given in the Table at page 141.

Acetic Acid	$H, C^2H^3O^2$	60.
— Anhydrous	$C^2H^3, C^2H^3O^3$	102.
Acetone	CH^3, C^2H^3O	58.
Acetyl	C^2H^3	27.
Aconyl	C^2H	25.
Acryl	C^3H^3	39.
Adipic Acid	$H, C^3H^4O^2$	73.
Adipyl	C^3H^4	40.
Alcohol	H, C^2H^5O	46.
Aldehyde	H, C^2H^3O	44.
Alumina	$AlcAlcO$	34.
— Tersulphate	$AlcSO^2$	57.
Aluminic radical	Alc	9.
Aluminous radical	Al	13.5
Alum, Ammonia, <i>cryst.</i>	$NH^4, SO^2 + 3AlcSO^2 + Aq^{12}$	453.
Alum, Potash, <i>cryst.</i>	$KSO^2 + 3AlcSO^2 + Aq^{12}$	474.
Amidogen	NH^2	16.
Ammonia	NH^2, H	17.
— Carbonate (<i>in solution</i>)	NH^4, NH^4, CO^3	96.
— — Bicarbonate	H, NH^4, CO^3	79.
— — Sesquicarbonate (<i>in sol.</i>)	$(H, NH^4, CO^3)^2 + NH^4, NH^4, CO^3$	254.
— Hydrochlorate	$NH^2, H + HCl$	53.5
— Molybdate	NH^4, MoO^2	98.
— Nitrate	NH^4, NO^3	80.
— Oxalate	NH^4, CO^2	62.
— Sulphate	NH^4, SO^2	66.
— Soda-Phosphate	$NH^4, Na, H; PO^4 + Aq^4$	209.
Ammonium	NH^4	18.
— Chloride	NH^4, Cl	53.5
— Iodide	NH^4, I	145.
— Sulphide	NH^4, S	34.
— — Bisulphide	H, NH^4, S^2	51.
Amyl (Salts of, <i>see page 142</i>)	C^5H^{11}	71.
Anilin	NH, C^6H^5, H	93.
Antimony = Sb (Stibous), and Sbc (Stibic), radicals.		
Stibic radical	Sbc	40.
— Teroxide	$SbcSbcO$	96.
— Hydride (Antimoniuretted Hydrogen)	$HSbc$	41.
— Terchloride	$SbcCl$	75.5
— Tersulphide	$SbcS$	56.
— Antimoniate	Sbc^3, SbO^4	304.
— Tartrate	$Sbc^3, C^2H^2O^4$	210.
— Potash-Tartrate	$K, C^2H^2O^3 + Sbc^3, C^2H^2O^4$	323.
Stibous radical	Sb	120.
— Pentachloride	$SbCl^4, Cl$	297.5

Stibous (Antimonic) Acid	HSbO_3	169.
— — Anhydrous	Sb, SbO_3	320.
— Pentasulphide	SbS_4, S	200.
Arsenic radical	Asc	25.
— Oxide (White Oxide)	Asc, AscO	66.
— Terchloride	AscCl	60.5
— Teriodide	AscI	152.
— Tersulphide (Orpiment)	AscS	41.
— Hydride (Arseniuretted Hydrogen) HAsc		26.
Arsenous radical	As	75.
— Oxide (Suboxide)	As, AsO	166.
— Arsenic Acid, Monobasic	H, AsO_3	124.
— — Bibasic	$\text{H}^4, \text{As}_2\text{O}_7$	266.
— — Terbasic	H^3, AsO_4	142.
— — Anhydrous	As, AsO_3	230.
— Bisulphide (Realgar)	AsS_2	107.
— Pentasulphide	AsS_4, S	155.
— Arsenious Acid, Monobasic	H, AsO_2	108.
— — Bibasic	$\text{H}^4, \text{As}_2\text{O}_5$	234.
— — Terbasic	H^3, AsO_3	126.
— — Anhydrous	As, AsO_3	198.
Barium	Ba	68.5
— Protoxide	BaBaO	153.
— Peroxide	BaO	84.5
— Chloride	BaCl	104.
— — <i>cryst.</i>	$\text{BaCl} + \text{Aq}$	122.
— Silico-Fluoride	BaSi^2F^3	139.5
— Sulphide	BaS	84.5
Barytes	BaBaO	153.
— Hydrate	BaHO	85.5
— — <i>cryst.</i>	$\text{BaHO} + \text{Aq}^4$	157.5
— Acetate, <i>cryst.</i>	$\text{Ba, C}^2\text{H}^3\text{O}^2 + 1\frac{1}{2}\text{Aq}$	154.5
— Carbonate	Ba, Ba; CO_3	197.
— Chromate	BaCrO_2	127.5
— Nitrate	BaNO_3	130.5
— Sulphate	BaSO_2	116.5
Benzole	$\text{H, C}^6\text{H}^5$	78.
Benzyl	C^7H^5	89.
— Benzoic Acid	$\text{H, C}^7\text{H}^5\text{O}^2$	122.
— — Anhydride	$\text{C}^7\text{H}^5, \text{C}^7\text{H}^5\text{O}^3$	226.
— Oil of Bitter Almonds	$\text{H, C}^7\text{H}^5\text{O}$	106.
Bismuthous radical	Bi	210.
— Bismuthic Acid	H, BiO_3	259.
— — Anhydride	Bi, BiO_5	500.
— Bisulphide	BiS^2	242.

Bismuthous Oxychloride	BiClO	261.5
Bismuthic radical	Bic	70.
— Oxide	BicBicO	156.
— Terchloride	BicCl	105.5
— Teriodide	BicI	197.
— Nitrate	Bic ³ NO ⁴	288.
— — Ternitrate	BicNO ³	132.
— Tersulphide	BicS	86.
Bleaching Powder	CaCl ₂ .HO + CaHO	109.5
Boracic Acid	HBO	20.5
— Anhydride	BBO	23.
Boron	B	3.5
— Chloride	BCl	39.
— Fluoride	BF	22.5
Bromic Acid	HBrO ³	129.
Bromhydric Acid	HBr	81.
Bromine	Br	80.
Butyl	C ⁴ H ⁹	57.
Butylic Alcohol	H, C ⁴ H ⁹ O	74.
Butyryl	C ⁴ H ⁷	55.
Butyric Acid	H, C ⁴ H ⁷ O ²	88.
— Anhydride	C ⁴ H ⁷ , C ⁴ H ⁷ O ³	158.
Cadmium	Cd	56.
— Oxide	Cd, CdO	128.
— Bromide	CdBr	136.
— Nitrate	Cd, NO ³	118.
— Sulphate, <i>cryst.</i>	Cd, SO ² + Aq ²	140.
— Sulphide	CdS	72.
Calcium	Ca	20.
— Oxide (Quick-lime)	Ca, CaO	56.
— Hydrated Oxide	Ca, HO	37.
— Chloride	CaCl	55.5
— — <i>cryst.</i>	CaCl + Aq ³	109.5
— Fluoride	CaF	39.
— Sulphide	CaS	36.
Caproyl	C ⁶ H ¹¹	83.
Caproic Acid	H, C ⁶ H ¹¹ O ²	116.
Capryl	C ⁸ H ¹⁵	111.
Caprylic Acid	H, C ⁸ H ¹⁵ O ²	144.
Carbon	C	12.
Carbonic Acid	CO ²	44.
Carbonic Oxide	CO	28.
Carbon, Sulphide	CS ⁴	76.
Cerous radical, Ce, 46.	Ceric radical, Cec	30.66
Cerotyl	C ²⁷ H ⁵³	377.

Cerotic Acid	H, C ²⁷ H ⁵³ O ²	410.
Ceryl	C ²⁷ H ⁵⁵	379.
Cetyl	C ¹⁶ H ³³	225.
Chlorine	Cl	35.5
Chloric Acid	HClO ³	84.5
Chlorhydric Acid	HCl	36.5
Chloroform	H, CCl ³	119.5
Chromous radical	Cr	27.
— Chromic Acid (<i>in solution</i>).	HCrO ²	60.
— — Anhydride	Cr, CrO ³	102.
— Oxychloride	CrClO	78.5
Chromic radical	Cr ₂	18.
— Sesquioxide	Cr ₂ Cr ₂ O	52.
Cinnamic Acid	H, C ⁹ H ⁷ O ²	148.
Cinnamyl	C ⁹ H ⁷	115.
Citric Acid (<i>tribasic</i>)	HHH; C ⁶ H ⁵ O ⁷	192.
— — <i>commercial crystals</i>	HHH; C ⁶ H ⁵ O ⁷ + Aq	210.
— <i>as a triple acid</i>	H, C ² H ³ O ³ + 2(H, C ² HO ²)	192.
Cobaltous radical	Co	29.5
— Oxide	Co, CoO	75.
Cobaltic radical	Coc	19.66
— Oxide (Sesquioxide)	Coc, CocO	55.33
Copper = Cu (Cuprous), and Cuc (Cupric), radicals.		
Cuprous radical	Cu	63.5
— Oxide (Red Oxide)	Cu, CuO	143.
— Chloride (Protochloride)	CuCl	99.
— Sulphide	CuS	79.5
Cupric radical	Cuc	31.75
— Oxide (Black Oxide)	Cuc, CucO	79.5
— Acetate, <i>cryst.</i>	Cuc, C ² H ³ O ² + $\frac{1}{2}$ Aq	99.75
— Chloride (Perchloride)	CucCl	67.25
— Nitrate	CucNO ³	93.75
— Sulphate, <i>cryst</i>	CucSO ² + 2 $\frac{1}{2}$ Aq	124.75
— Sulphide	CucS	47.75
Cumenyl	C ⁹ H ¹¹	119.
Cuminic Acid	H, C ¹⁰ H ¹¹ O ²	164.
Cumyl	C ¹⁰ H ¹¹	131.
Cyanic Acid	H, CNO	43.
Cyanogen	CN or Cy	26.
Cyanhydric Acid	H, CN	27.
Didymium	D	48.
Ether (Sulphuric)	C ² H ⁵ , C ² H ⁵ O	74.
Ethyl (Salts of, <i>see</i> page 145)	C ² H ⁵	29.
Fluorine	F	19.
Formyl	CH	13.

Formyl, Formic Acid	H,CHO ²	46.
— Pyrogallic Acid	CH,CHO	42.
Gallic Acid, <i>cryst.</i>	H ³ ,C ⁷ H ⁵ O ⁶ = H,C ³ H ³ O ² + 2H,C ² H ² O ² ?	188.
Glucinum	G	4.7
Glucina	G,GO	25.4
— Sulphate	GSO ²	52.7
Glycerine (<i>tribasic</i>)	HHH,C ³ H ⁵ O ³	92.
Glycyl	C ³ H ⁵	41.
Gold = Au (Aurous), and Auc (Auric), radicals.		
Aurous radical	Au	196.5
— Chloride	AuCl	232.
Auric radical	Auc	65.5
— Chloride	AucCl	101.
— Sodium-Chloride	NaAuc ³ Cl ⁴	361.5
Grape Sugar	CH ² O	30.
Heptyl	C ⁷ H ¹⁵	99.
Hexyl	C ⁶ H ¹³	85.
Hydriodic Acid	HI	128.
Hydrobromic Acid	HBr	81.
Hydrochloric Acid	HCl	36.5
Hydrocyanic Acid	H,CN	27.
Hydrofluoric Acid	HF	20.
Hydrofluosilicic Acid	HSi ² F ³	72.
Hydrosulphuric Acid	HS	17.
Hydrogen	H	1.
— Oxide (Peroxide)	HO	17.
— Binoxide (Ozone)	HO ²	33.
Indigo Blue	NH ² ,C ⁸ H ³ O	131.
— White	NH ⁴ ,C ⁸ H ³ O + NH ² ,C ⁸ H ³ O	264.
— Sulphate	NH,C ⁸ H ³ ;SO ² + HSO ²	211.
Indyl	C ⁸ H ³	99.
Iodic Acid.	HIO ³	176.
Iodine	I	127.
Iridous radical, Ir, 99.	Iridic radical, Irc	66.
Iron = Fe (Ferrosium), and Fec (Ferricum).		
Ferrous radical	Fe	28.
— Oxide (Protoxide)	Fe,FeO	72.
— Carbonate	FeFe,CO ³	116.
— Chloride	FeCl	63.5
— Iodide	FeI	155.
— Sulphate	FeSO ²	76.
— — <i>cryst.</i>	FeSO ² + 3½Aq	139.
— Ammonium-Sulphate	FeSO ² ,NH ⁴ SO ² + Aq ³	196.
— Sulphide	FeS	44.
— — Bisulphide	FeS ²	60.

Ferrous Ferric Oxide . . .	FeFec^3O^2	116.
Ferric radical	Fec	18.66
— Acetate	$\text{Fec}, \text{C}^2\text{H}^3\text{O}^2$	77.66
— Oxide (Sesquioxide). . . .	Fec, FecO	53.33
— Chloride	FecCl	54.16
— — <i>cryst.</i>	$\text{FecCl} + \text{Aq}^2$	90.16
— Sulphate	FecSO^2	66.66
— Ammonium-Sulphate	$\text{FecSO}^2, \text{NH}^4\text{SO}^2 + \text{Aq}$	150.66
— Sulphide	FecS	34.66
— Acid	$\text{H}, \text{Fec}^3\text{O}^4$	121.
Lactic Acid	$\text{H}, \text{C}^3\text{H}^5\text{O}^3$	90.
Lanthanum	La	46.
Lauryl	$\text{C}^{12}\text{H}^{23}$	167.
Lauric Acid	$\text{H}, \text{C}^{12}\text{H}^{23}\text{O}^2$	200.
Lead	Pb	103.5
— Yellow Oxide (Litharge) . .	Pb, PbO	223.
— Red Oxide	Pb^3O^2	342.5
— Orange Oxide	Pb^4O^3	462.
— Brown Oxide	PbO	119.5
— Acetate	$\text{Pb}, \text{C}^2\text{H}^3\text{O}^2$	162.5
— — <i>cryst.</i>	$\text{Pb}, \text{C}^2\text{H}^3\text{O}^2 + \frac{1}{2}\text{Aq}$	189.5
— Carbonate	PbPb, CO^3	267.
— — Basic (White Lead) . . .	$\text{HPb}^3, \text{CO}^4$	387.5
— Chloride	PbCl	139.
— Chromate	PbCrO^2	162.5
— Fluoride	PbF	122.5
— Iodide	PbI	230.5
— Nitrate	PbNO^3	165.5
— Oxalate	PbCO^2	147.5
— Sulphate	PbSO^2	151.5
— Sulphide	PbS	119.5
Lime (Calcium Oxide)	Ca, CaO	56.
— Hydrate (Slaked Lime) . . .	CaHO	37.
— Acetate, <i>anhydrous</i>	$\text{Ca}, \text{C}^2\text{H}^3\text{O}^2$	79.
— Carbonate	CaCa, CO^3	100.
— Chloride	$\text{CaCl}, \text{HO} + \text{CaHO}$	109.5
— Citrate, <i>anhydrous</i>	$\text{Ca}^3; \text{C}^6\text{H}^5\text{O}^7?$	249.
— Nitrate, <i>cryst.</i>	$\text{Ca}, \text{NO}^3 + \text{Aq}^2$	118.
— Oxalate, <i>anhydrous</i>	CaCO^2	64.
— — <i>cryst.</i>	$\text{CaCO}^2 + \text{Aq}$	82.
— Phosphate	$\text{Ca}^4, \text{P}^2\text{O}^7$	254.
— — <i>cryst.</i>	$\text{Ca}^4, \text{P}^2\text{O}^7 + \text{Aq}^4$	326.
— — <i>Bone-earth</i>	Ca^3, PO^4	155.
— Sulphate	Ca, SO^2	68.
— Sulphate, <i>cryst.</i> (Gypsum) .	$\text{Ca}, \text{SO}^2 + \text{Aq}$	86.

Lithia	L,LO	29.
Lithium	L	6.5
Magnesia (<i>calcined</i>)	Mg, MgO	40.
— Carbonate	MgMg, CO ³	84.
— Phosphate.	Mg ⁴ , P ² O ⁷	222.
— Sulphate	MgSO ²	60.
— — <i>cryst.</i>	MgSO ² + 3½Aq	123.
Magnesium	Mg	12.
— Chloride	MgCl	47.5
Maleic Acid	H, C ² HO ²	58.
Maleyl	C ² H	25.
Malic Acid (<i>basic</i>)	H ² , C ⁴ H ⁴ O ⁵	134.
— as a double acid	= H, C ² H ³ O ³ + H, C ² HO ²	134.
Manganous radical	Mn	27.5
— Oxide (Protoxide)	MnMnO	71.
— — (Peroxide)	MnO	43.5
— Chloride	MnCl	63.
— Manganic Acid	HMnO ²	60.5
— Sulphate, <i>cryst.</i>	MnSO ² + 3½Aq	138.5
Manganic radical	Mnc	18.33
— Oxide (Sesquioxide).	MncMncO	52.66
— Red Oxide	MnMnc ³ O ²	114.5
— — Manganite	HMnc ³ O ²	88.
— Chloride	MncCl	53.83
— Permanganic Acid	HMnc ³ O ⁴	120.
Margaryl	C ¹⁷ H ³³	237.
Margaric Acid	H, C ¹⁷ H ³³ O ²	270.
Marsh Gas	CH ³ , H	16.
Mercaptan	H, C ² H ⁵ ; S ²	62.
Mercury = Hg (Mercurous), and Hgc (Mercuric), radicals.		
Mercurous radical	Hg	200.
— Oxide (Black Oxide)	Hg, HgO	416.
— Bromide	HgBr	280.
— Chloride (Calomel)	HgCl	235.5
— Chromate	HgCrO ²	259.
— Iodide (Yellow)	HgI	327.
— Nitrate, <i>cryst.</i>	HgNO ³ + Aq	280.
— — <i>Basic</i>	2HgNO ³ + HgH ³ O ²	759.
— Sulphate	HgSO ²	248.
— Sulphide	HgS	216.
Mercuric radical	Hgc	100.
— Oxide (Red Oxide)	HgcHgcO	216.
— Bromide	HgcBr	180.
— Chloride (Sublimate)	HgcCl	135.5
— — White Precipitate	NH ² Hgc ² , Cl	251.5

Mercuric Cyanide	HgcCN	126.
— Iodide (Red)	HgcI	227.
— Nitrate	HgcNO ³	162.
— Persulphate	HgcSO ²	148.
— Sulphide	HgcS	116.
Methyl (Salts of, <i>see</i> page 147)	CH ³	15.
Melissic Acid	H,C ³⁰ H ⁵⁹ O ²	452.
Melissyl	C ³⁰ H ⁵⁹	419.
Molybdous radical	Mo	48.
— Molybdic Acid	HMoO ²	81.
— — Anhydrous	Mo,MoO ³	144.
— Sulphide	MoS ²	80.
— Oxychloride	MoClO	99.5
Molybdic radical	Moc	16.
— Sulphide	MocS	32.
Mineral Chameleon	KMnc ³ O ⁴	158.
Muriatic Acid	HCl	36.5
Myricyl	C ³⁰ H ⁶¹	421.
— Palmitate	C ³⁰ H ⁶¹ ,C ¹⁶ H ³¹ O ²	676.
Naphtyl	C ¹⁰ H ⁷	127.
Niccolous radical	Ni	29.5
— Oxide (Protoxide)	Ni,NiO	75.
Niccolic radical	Nic	19.66
— Oxide (Sesquioxide).	Nic,NicO	55.33
Nitric Acid	H,NO ³	63.
— Anhydride	N,NO ⁵	108.
Nitrous Acid	H,NO ²	47.
— Anhydride	N,NO ³	76.
Nitrogen	N	14.
— Protoxide	N,NO	44.
— Deutoxide	NO	30.
— Peroxide	NOO	46.
Octyl	C ⁸ H ¹⁷	113.
— Acetate	C ⁸ H ¹⁷ ,C ² H ³ O ²	172.
œnanthyl	C ⁷ H ¹³	97.
œnanthylic Acid.	H,C ⁷ H ¹³ O ²	130.
Olefiant Gas	CH ²	14.
Oleic Acid	H,C ¹⁸ H ³³ O ²	282.
Oleyl	C ¹⁸ H ³³	249.
Osmous radical, Os, 99.5	Osmic radical, Osc	66.33
Oxalic Acid, <i>effloresced</i>	H,CO ²	45.
— <i>crystallised</i>	H,CO ² + Aq	63.
Oxygen	O	16.
Ozone	HO ²	33.
Palladous radical, Pd, 53.2	Palladic radical, Pdc	26.6

Palmityl	$C^{16}H^{31}$	223.
Palmitic Acid	$H, C^{16}H^{31}O^2$	256.
Palmitone	$C^{15}H^{31}, C^{16}H^{31}O$	450.
Phenyl	C^6H^5	77.
— Hydride (Benzole)	C^6H^5, H	78.
Phosgene Gas	CCl, ClO	99.
Phtalic Acid	$H, C^4H^2O^2$	83.
Phtalyl	C^4H^2	50.
Phosphorus	P	31.
Phosphoric Acid, <i>monobasic</i>	H, PO^3	80.
— — <i>bibasic</i>	H^4, P^2O^7	178.
— — <i>tribasic</i>	H^3, PO^4	98.
— — <i>anhydride</i>	P, PO^5	142.
Phosphuretted Hydrogen	PH^3 or PH^2, H	34.
Platinous radical	Pt	99.
— Chloride	$PtCl$	134.5
Platinic radical	Ptc	49.5
— Chloride	$PtcCl$	85.
— Ammonio-Chloride	$NH^4, Cl + 2PtcCl$	223.5
— Potassio-Chloride	$KCl + 2PtcCl$	244.5
— Sodio-Chloride	$NaCl + 2PtcCl$	228.5
Potash, Anhydrous	KKO	94.
— Hydrate	KHO	56.
— Acetate	$K, C^2H^3O^2$	98.
— Antimoniate	$KSbO^3$	207.
— Arseniate	H^2K, AsO^4	180.
— Arsenite	$KAsO^2$	146.
— Carbonate	KK, CO^3	138.
— — Bicarbonate, <i>cryst.</i>	HK, CO^3	100.
— Chlorate	$KClO^3$	122.5
— — Perchlorate	$KClO^4$	138.5
— Chromate, Red	$2KCrO^2 + CrCrO^3$	298.
— — Yellow	$KCrO^2$	98.
— Iodate	KIO^3	214.
— Manganate	$KMnO^2$	98.5
— — Permanganate	$KMnc^3O^4$	158.
— Nitrate	KNO^3	101.
— Oxalate	KCO^2	83.
— — Binoxalate	$KCO^2, HCO^2 + Aq$	146.
— — Quadroxalate	$KCO^2 + 3HCO^2$	218.
— Prussiate, Red	$KCy + FecCy$	109.66
— — Yellow	$2KCy + FeCy$	184.
— — — <i>cryst.</i>	$2KCy + FeCy + 1\frac{1}{2}Aq$	211.
— Sulphate	KSO^2	87.
— — Bisulphate	$KSO^2 + HSO^2$	136.

Potash, Hyposulphite	$\text{KSO} + \text{HSO}$	104.
— Tartrate	$\text{K}, \text{C}^2\text{H}^2\text{O}^3$	113.
— — Bitartrate	$\text{K}, \text{C}^2\text{H}^2\text{O}^3 + \text{H}, \text{C}^2\text{H}^2\text{O}^3$	188.
— — Soda-Tartrate	$\text{K}, \text{C}^2\text{H}^2\text{O}^3 + \text{Na}, \text{C}^2\text{H}^2\text{O}^3 + \text{Aq}^4$	282.
Potassium	K	39.
— Bromide	KBr	119.
— Chloride	KCl	74.5
— Cyanide	K, CN	65.
— — Sulpho-Cyanide	$\text{K}, \text{CN}; \text{S}^2$	97.
— Ferridcyanide	$\text{KCy} + \text{FecCy}$	109.66
— Ferrocyanide	$\text{KCy}, \text{KCy} + \text{FeCy}$	184.
— — <i>cryst.</i>	$\text{KCy}, \text{KCy}, \text{FeCy} + 1\frac{1}{2}\text{Aq}$	211.
— Fluoride	KF	58.
— Fluo-Silicide	KSi^2F^3	110.
— Iodide	KI	166.
— Sulphide	KS	55.
— — Pentasulphide	KS^4, S	119.
Propionic Acid	$\text{H}, \text{C}^3\text{H}^5\text{O}^2$	74.
Propionyl	C^3H^5	41.
Propyl	C^3H^7	43.
Propylic Alcohol	$\text{H}, \text{C}^3\text{H}^7\text{O}$	60.
Prussic Acid	H, CN	27.
Prussian Blue	$\text{FecCy}, \text{FecCy}, \text{FeCy}$	143.33
— Turnbull's	$\text{FecCy}, \text{FeCy}$	98.66
Pyrogallic Acid	CH, CHO	42.
Rhodos radical, Rh, 52.	Rhodic radical, Rhc	34.66
Ruthous radical, Ru, 52.	Ruthic radical, Ruc	34.66
Rutic Acid	$\text{H}, \text{C}^{10}\text{H}^{19}\text{O}^2$	172.
Rutyl	$\text{C}^{10}\text{H}^{19}$	139.
Salicylic Acid	$\text{H}^2, \text{C}^7\text{H}^4\text{O}^3$	138.
Salicylous Acid	$\text{H}, \text{C}^7\text{H}^5\text{O}^2$	122.
Salicyl	C^7H^4	88.
Sebacic Acid	$\text{H}, \text{C}^8\text{H}^8\text{O}^2$	101.
Sebamyl	C^8H^8	68.
Selenium	Se	40.
Silica (Silicic Acid)	SiSiO	30.
Silicon	Si	7.
— Chloride	SiCl	42.5
— Fluoride	SiF	26.
Silver	Ag	108.
— Oxide	Ag, AgO	232.
— — Peroxide	AgO	124.
— Arseniate (<i>terbasic</i>)	Ag^3AsO^4	463.
— Bromide	AgBr	188.
— Chlorate	AgClO^3	191.5

Silver, Chloride	AgCl	143.5
— Cyanide	AgCy	134.
— Fluoride	AgF	127.
— Iodide	AgI	235.
— Nitrate	AgNO ³	170.
— Phosphate (<i>terbasic</i>)	Ag ³ PO ⁴	419.
— — (<i>bibasic</i>)	Ag ⁴ P ² O ⁷	606.
— Sulphate	AgSO ²	156.
— Sulphide	AgS	124.
Soda, Anhydrous	Na, NaO	62.
— Hydrate	NaHO	40.
— Acetate, <i>cryst.</i>	Na, C ² H ³ O ² + Aq ³	136.
— Arsenite	NaAsO ² Δ	130.
— Borate, Anhydrous	Na ² B ¹² O ⁷ = 2NaBO + 5BBO	200.
— — <i>cryst</i>	NaBO + 5HBO + 2 $\frac{1}{2}$ Aq	190.
— Carbonate	NaNa, CO ³	106.
— — <i>cryst.</i>	NaNa, CO ³ + Aq ¹⁰	286.
— — Bicarbonate	NaH, CO ³	84.
— Nitrate	NaNO ³	85.
— Phosphate.	HNa ² , PO ⁴	142.
— — <i>cryst.</i>	HNa ² , PO ⁴ + Aq ¹² .	358.
— — Pyrophosphate	Na ⁴ , P ² O ⁷	266.
— — — <i>cryst.</i>	Na ⁴ , P ² O ⁷ + Aq ¹⁰	446.
— Sulphate	NaSO ²	71.
— — <i>cryst.</i>	NaSO ² + Aq ⁵	161.
— — Bisulphate	NaSO ² + HSO ²	120.
— Hyposulphite, <i>cryst.</i>	NaSO + HSO + Aq ²	124.
— Tartrate	Na, C ² H ² O ³	97.
Sodium	Na	23.
— Protoxide	Na, NaO	62.
— Chloride	NaCl	58.5
— Fluoride	NaF	42.
— Fluo-Silicide	NaSi ² F ³	94.
— Iodide	NaI	150.
— Sulphide	NaS	39.
Strontian	Sr, SrO	104.
— Carbonate	Sr ² CO ³	148.
— Nitrate, <i>cryst.</i>	SrNO ³ + 2 $\frac{1}{2}$ Aq	151.
— Sulphate	SrSO ²	92.
Strontium	Sr	44.
— Chloride, <i>cryst.</i>	SrCl + Aq ³	133.5
Stearic Acid	H, C ¹⁸ H ³⁵ O ²	284.
Stearyl	C ¹⁸ H ³⁵	251.
Suberic Acid	H, C ⁴ H ⁶ O ²	87.
Suberyl	C ⁴ H ⁶	54.

Succinic Acid, <i>cryst.</i>	$H, C^2H^2O^2$	59.
— — <i>sublimed</i>	$2(H, C^2H^2O^2) + C^2H^2, C^2H^2O^3$	218.
— Anhydride	$C^2H^2, C^2H^2O^3$	100.
Succinyl	C^2H^2	26.
Sulphur	S	16.
Sulphuretted Hydrogen . . .	HS	17.
Sulphuric Acid	HSO^2	49.
— Anhydride	S, SO^3	80.
Sulphurous Acid	SO	32.
Tartryl	C^2H^2	26.
Tartaric Acid (<i>monobasic</i>), <i>cryst.</i>	$H, C^2H^2O^3$	75.
— — (<i>terbasic</i>)	$H^3, C^2H^2O^4$	93.
— Anhydride	$C^2H^2, C^2H^2O^5$	132.
Tellurous radical, Te, 64.	Telluric radical, Tec	32.
Telluretted Hydrogen	HTe	65.
Thorium	Th	59.5
Tin,— Stannous radical	Sn	59.
— Stannic radical	SnC	29.5
Stannous Oxide	SnSnO	134.
— Chloride, <i>cryst.</i>	$SnCl + Aq.$	112.5
— — Ammonium-Chloride	$SnCl, NH^4Cl + \frac{1}{2}Aq$	157.
— Sulphide	SnS	75.
Stannic Oxide	SnCSnCO	75.
— Chloride	SnCCL	65.
— Sulphide	SnCS	45.5
Titanium	Ti	12.
Tungsten (Wolfram)	W	92.
Tungstic Acid	HWO^2	125.
— Anhydride	W, WO^3	232.
Urea	NH^4, CyO	60.
Uric Acid, <i>crystallised</i>	$C^5H^4N^4O^3 + Aq?$	186.
Uranous radical, U, 60.	Uranic radical, Uc	40.
Vanadous radical, V, 68.4	Vanadic radical, Vc	22.8
Valerianic Acid	$H, C^5H^9O^2$	102.
Valeryl	C^5H^9	69.
Vinyl (<i>Olefiant gas</i>)	CH^2	14.
Water	H, HO	18.
Zinc	Zn	32.75
— Oxide	ZnZnO	81.5
— Carbonate (<i>precipitated</i>)	$Zn^2CO^3 + 3ZnHO$	274.75
— Chloride	ZnCl	68.25
— Sulphate, <i>cryst.</i>	$ZnSO^2 + 3\frac{1}{2}Aq$	143.75
— Sulphide	ZnS	48.75
Zirconia	ZrZrO	60.
Zirconium	Zr	22.

ELEMENTARY EXPERIMENTS.

THE object of this set of Elementary Experiments is to render the student familiar with some of the more important chemical operations, without a knowledge of which he cannot proceed a step in safety. Being only introductory to the extended systematic course of experiments, their subjects are very simple. I have endeavoured to render them as easy of performance as possible; and I believe that, if the instructions are strictly followed, the student will meet with few difficulties.

The experiments are so contrived that they can be performed, either by a single student, or by a considerable number at the same time, working according to dictation. I make this remark to account for the precision of the details that are given under some heads, and the peculiarity of the style.

ALTERATION OF VEGETABLE COLOURS BY ACIDS AND ALCALIES.

a. Action of Nitric Acid on Blue Litmus.

Half fill a conical test glass with water.

Add to it three drops of diluted nitric acid.

Stir the mixture with a glass rod.

Dip into it a slip of blue litmus test paper.

Observe that the *blue* colour changes to *red*.

Put the stirrer to your tongue and *taste* the mixture.

You will find it to have a *sour* or *acid* taste.¹

¹ The test glass that is best adapted for these experiments, is of a conical shape with a lip. It is called Clark's Test Glass, fig. 1. Water in small quantities is conveniently supplied by means of the water-bottle, fig. 2. This apparatus consists of a glass bottle, to which two glass tubes are fitted by a cork. Through one tube, *a*, air enters the bottle, while water escapes through *b*, the other tube. It answers very well for giving a small quiet stream of water, for filling tubes, wetting papers, and the like.



2.



1.

b. Action of Nitric Acid on Yellow Turmeric.

Take the diluted nitric acid prepared in Experiment *a*.

Dip into it a slip of yellow turmeric test paper.

Observe that the yellow colour remains unchanged.

The drops of acid are most conveniently added by means of a straight pipette, or narrow glass tube, open at both ends, usually called the dropping tube, fig. 3. It may be 6 inches long, and not less than $\frac{1}{8}$ inch in diameter, having a very small orifice but not a capillary point, at one end. See Griffin's "*Chemical Manipulation*," from which the following quotation is made:—

“In using such a tube in testing, it is seldom necessary to suck with the mouth. On dipping the tube into the test, a

3. portion enters, more or less of it, according to the depth of the dip. As much as may be required is allowed to enter, and is retained by applying a moistened finger to the top of the tube,—and just as much as may be wished is allowed to drop into the solution under examination, by a partial or complete removal of the finger.

“A modification of this method of applying tests by dropping tubes, may be advantageously employed where a large number of students in a class are furnished with solutions for analysis, and are all to apply the same tests to their solutions.

Two-ounce bottles should be provided with large and good corks, perforated and fitted with pieces of straight glass tube of the width represented in the margin, and so long as to rise half an inch above the cork, and to descend

4. nearly to the bottom of the bottles. The lower end of the tubes may be a little contracted.

The test solutions are to be put into these bottles, and the tubes used to remove them as required. The cork must stand so high above the bottle as to be easily caught by the thumb and middle finger of the right hand, while the forefinger is left at liberty to close or open the upper part of the tube, as may be required. The tests are under complete control in this apparatus, so that any quantity which an experiment may demand, can be administered with facility. When a very small quantity of the re-agent is required, you lift the tube without closing its upper end. It then acts like a glass rod, and takes up only a drop or two. When you want a larger quantity, you lift the tube out of the liquid, close the upper end by your forefinger, plunge the closed tube into the liquid, and remove your finger. The air in the bottle then presses the liquid up the tube con-

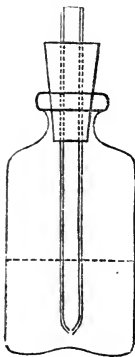

5.

c. *Action of Ammonia on Yellow Turmeric.*

Half fill a conical test glass with water.

Add to it three drops of Liquid Ammonia.

Stir the mixture with a glass rod.

Dip into it a slip of yellow turmeric test paper.

Observe that the *yellow* colour changes to *brown*.

Put the stirrer to your tongue and *taste* the mixture.

You will find it to have an *acid* or *alkaline* taste.

siderably higher than the level in the bottle. The tube can then be lifted with what it contains."

Another excellent form of bottle for containing liquors to be used in testing, is shown by fig. 6. It has a wide mouth, and, instead of a stopper, is furnished with a glass cap, ground to fit the outside of the neck. It is also provided with a pipette, the orifice of which is so small that it cannot deliver above one drop of liquor at a time, though, at the pleasure of the operator, it can give many drops in succession. The pipette always remains in the bottle. Of course, it is always ready for use, requires no cleaning, prevents the waste of the reagent, and is an effectual check on the overdosing of any liquor that is to be tested.



6.

Every test glass should be accompanied by a stirrer of the size and form of fig. 7.

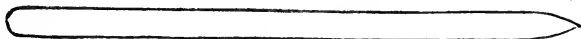

7.

The slip of test paper may be $2\frac{1}{2}$ inches long, $\frac{1}{8}$ inch wide. Such slips are to be had bound up in little books, like banker's cheque books, fig. 8.

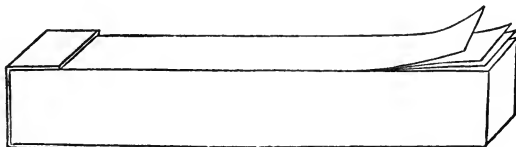

8.

The test papers made of this size are coloured carefully for delicate testing. When the purpose for which they are used is merely demonstrative, as in Lectures, it is better to use larger papers more strongly coloured, that the changes of colour may be easily seen at a distance. Such test papers are now prepared for sale.

d. Action of Ammonia on Blue Litmus.

Take the diluted ammonia prepared in Experiment *c*.

Dip into it a slip of blue litmus test paper.

Observe that the blue colour remains unchanged.

e. Counter-Actions of Nitric Acid and Ammonia.¹

Take the diluted nitric acid prepared in Experiment *a*.

And the diluted ammonia prepared in Experiment *c*.

Dip into the acid a slip of blue litmus test paper.

Dip the reddened paper into the ammonia.

Observe that the *redness* disappears and the *blue* colour returns.

Dip into the ammonia a slip of yellow turmeric test paper.

Then dip the brown part into the acid.

Observe that the brown colour disappears and the yellow colour returns.

f. Action of Carbonate of Soda on Red Litmus.

Take a slip of red litmus test paper.

Wet it with water from the water bottle.

Put on the wet paper a crystal of carbonate of soda.

Observe that the *red* colour changes to *blue*.

g. Action of Carbonate of Soda on Yellow Turmeric.

Take a slip of yellow turmeric test paper.

Wet it with water from the water bottle.

Put on the wet paper a crystal of carbonate of soda.

Observe that the *yellow* colour changes to *brown*.

h. Other Counter-Actions of Acids and Alkalies.

Half fill a conical test glass with blue cabbage liquor.²

Add to it a few drops of diluted sulphuric acid.

Observe that the *blue* colour changes to *red*.

Take a straight pipette in your left hand.

Take up in the pipette some solution of potash.

¹ Instead of nitric acid, you may take muriatic, sulphuric, acetic, or oxalic acid; and instead of ammonia you may take caustic potash or caustic soda, for these experiments. The effects produced by the reagents of each set will be similar.

² To prepare blue cabbage liquor, chop up some leaves of blue cabbage, pour boiling water over them, and after some hours decant the blue liquor for use. It soon becomes mouldy, but can be preserved by adding to it as much oil of vitriol as will make it strongly red. When required for use, a solution of soda or potash must be added to neutralise the acid.

Add the potash gradually to the coloured liquor.
 Stir the mixture with a glass rod held in your right hand.
 Observe that the *red* liquor regains its *blue* colour.
 And that with more potash it becomes *green*.
 With another pipette take diluted sulphuric acid.
 Add it gradually to the green mixture.
 Stir the mixture with a glass rod.
 Observe that the *green* colour changes first to *blue*, and finally to *red*.

Results of these Experiments :

i. We have demonstrated,—
 That blue litmus is changed to red by acids.¹
 That yellow turmeric is not changed in colour by acids.
 That brown turmeric is changed to yellow by acids.
 And from these demonstrations, we draw the general conclusion, that
acids change blue litmus to red, and brown turmeric to yellow.
 We have also found, that acids or substances which change blue litmus
 to red, have a peculiar *sour* or *acid* taste.

k. We have demonstrated,—
 That yellow turmeric is changed to brown by alcalies.
 That red litmus is changed to blue by alcalies.
 That blue litmus is not changed in colour by alcalies.
 And from these demonstrations we draw the general conclusion, that
alcalies change red litmus to blue, and yellow turmeric to brown.
 We have also found, that alcalies, or the substances which change red
 litmus to blue, have a peculiar *acid* or *alkaline* taste.

l. The experiments on the counter-actions of acids and alcalies, prove
 that these bodies have the faculty of *neutralising each other's power*.
 Hence, acids restore colours that have been altered by alcalies, and
 alcalies restore colours that have been altered by acids.

m. As respects the *application* of the knowledge derived from these
 experiments, I may remark, that when a substance reddens blue litmus,
 it is said to be *acid*; when it makes red litmus turn blue, or yellow

¹ These conclusions presuppose that the reactions have been tried,
 as suggested in Note ¹ page 34, with a few other acids and alcalies than
 those named in the text. It would hardly be right to draw sweeping
 general conclusions from the behaviour of one acid and one alcali
 towards the coloured tests; yet it would have been tedious to put more
 experiments in the text. The student can increase or vary the examples
 at pleasure.

turmeric turn brown, it is said to be *alkaline*. But the possession of this acid property is not sufficient to constitute what chemists call AN ACID, nor is the possession of the alkaline property sufficient to constitute AN ALCALI; because the power of altering vegetable colours is possessed by some substances which, properly speaking, are neither acids nor alkalies—as, for example, carbonate of soda, used in Experiment *f*. This substance is a *salt*, containing both carbonic acid and soda, that is, both an acid and an alkali. It cannot, therefore, be called *an acid*, nor yet *an alkali*, but it can very properly be said to be *alkaline*, for this term describes simply a property which the substance actually possesses, namely, that of alkalinity. There are other salts which contain both an acid and an alkali, and which, nevertheless, manifest an *acid reaction* on vegetable colours. Many salts of the metals have this property, and they are said to have *an acid reaction*. There is a third class of salts that have *no* action on vegetable colours, and that are neither acid nor alkaline in taste. Common salt is an example of this kind. Such substances are said to be *neutral*.

BLEACHING OF VEGETABLE COLOURS BY CHLORINE.

a. Bleaching of Blue Cabbage Liquor.

Put into a conical test glass a little blue cabbage liquor.

Add to it a few drops of solution of chlorine.¹

Stir the mixture with a glass rod.

The colour of the cabbage liquor is destroyed, and the mixture becomes white.

b. Bleaching of Indigo.

Half fill a conical test glass with water.

Add to it a few drops of sulphate of indigo.

Stir the mixture with a glass rod.

Add to it a small quantity of solution of chlorine gas,

Or of a clear solution of bleaching powder.

Stir the mixture with a glass rod.

The blue colour disappears and is succeeded by a pale greenish yellow.

c. Bleaching of Litmus Paper.

Half fill a conical test glass with solution of chlorine.

Dip into it a slip of blue litmus test paper.

Observe that the blue colour is bleached to white.

¹ A solution of chlorine gas in water can be preserved for some time in a good state for use, if closely corked up in an opaque bottle of salt-glazed stoneware. Directions for preparing the solution will be given under the head of Chlorine.

d. Bleaching of Pink Paper.

Take the solution of chlorine used in Experiment c.

Dip into it a slip of pink paper.

Or use any kind of paper stained with vegetable colours, or unbleached calico, or any kind of cloth tinged by colours of vegetable origin.

Observe that the colour is almost immediately destroyed (bleached).

e. Result of this Experiment :—Chlorine destroys vegetable colours. The experiment illustrates the art of bleaching cotton cloth by means of chlorine.

CHEMICAL METAMORPHOSES.

WHEN certain chemical bodies are placed in contact under particular circumstances, they combine together and produce new compounds possessed of new properties. These changes are evidenced to the eye by changes of colour and form, of taste and smell, of temperature and of bulk, which frequently are of a very surprising nature. The experiments adduced in proof of these facts will not, I hope, be considered out of place in a work devoted to CHEMICAL "RECREATIONS."

EXPERIMENTS WITH COLOURED LIQUIDS.

To produce a beautiful Green Liquid by mixing a Blue one with a Colourless one.

To produce a beautiful Crimson Liquid by mixing a Blue one and a Colourless one.

To change the Colour of a Liquid from Green to Red, by adding a Colourless one to it.

To make the same Liquid alternately Red and Green by the addition of two Colourless Liquids.

The methods of producing all these effects are detailed in Process *h*, on the Reactions of Acids and Alkalies with vegetable Colours, page 34.

A Liquor which is Crimson at the bottom, Purple in the middle, and Green at the top.—Nearly fill a tall cylindrical glass with water, and colour it blue by adding a tablespoonful of tincture of cabbage—then make it green at the top by gently adding a little liquid ammonia, and afterwards introduce a little sulphuric acid by means of a pipette, or glass tube, long enough to reach to the bottom of the vessel; upon which the effect above mentioned will be produced. If you stir the mixture with the glass tube, it will be blue, green, or red, according to the predominance of one or other of the ingredients. See page 35. If you add a little liquid chlorine, the colour will be totally destroyed. Page 36.

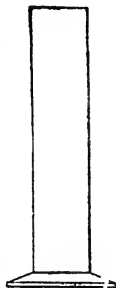



10.

Three different Colours produced from the same vegetable infusion by the addition of three Colourless Liquids.—Into each of three test glasses put a little diluted blue tincture of cabbage. To one add a solution of alum, to the second a solution of potash, and to the third a few drops of muriatic acid. The product of the first mixture will have a purple colour that of the second a bright green, and that of the third a beautiful crimson.

A beautiful Blue Liquid produced by mixing two Colourless ones.—Add a few drops of a solution of nitrate of copper to a glass of water—the mixture will be colourless if sufficiently dilute: pour a little liquid ammonia into it—the mixture will then assume a fine blue colour.—*Rationale.* The alkali precipitates the copper, and then re-dissolves it, forming a blue solution of the ammonia-nitrate of copper.

To produce a Colourless Liquid by mixing a deep Blue one with a Colourless one.—Add a little nitric acid to the blue liquid produced in the preceding experiment: upon which the colour instantly disappears.—*Rationale.* The blue compound is decomposed, and nitrate of ammonia and nitrate of copper are formed. These salts remain in solution in the water, the quantity of which renders the blue colour of the nitrate of copper insensible.

Coloured Liquors which become Colourless on the addition of a Colourless Liquor.—A solution of chlorine in water, or a solution of chloride of lime, deprives all vegetable solutions of their colour. Page 36.

ACTION OF ACIDS AND ALCALIES ON A VARIETY OF VEGETABLE COLOURS.—These experiments may be performed in conical test glasses or small test tubes.

Brazil Wood.—Boiled in 16 times its weight of water. A deeply-coloured red liquor. Alkalies turn it purple or violet. Iron salts turn it brown. Caustic potash in 200,000 parts of water acts upon it. Strong acids make it bright rose-red. Sulphuric acid has the most powerful action. The acid red liquor is a fine colour for prints on paper, but it injures the paper. Sulphurous acid bleaches it. Some of the weaker acids turn it yellow.

Paper saturated with Indigo dissolved in sulphuric acid.—Chlorine bleaches it. Boiling nitric acid does the same. Chromates and bromides bleach it cold. Iodides do the same, but leave a red stain on the paper that gradually disappears in the air.

Litmus.—Solution in water or alcohol. Blue. Acids redden it. Alkalies restore the blue colour.

Rhubarb infused in water. A bright yellow solution. Alkalies turn it reddish-brown. Very readily affected.

Rose leaves macerated in alcohol. Yellowish-brown liquid. Alkalies turn it green. Acids made it rose-red. The changes of colour in this solution are effected by an exceedingly small portion either of acid or alkali.

Turmeric.—Infusion in water, or tincture in alcohol. Yellow liquids. Alcalies turn them reddish brown.

Violets.—A violet liquor. Alcalies turn it green and acids red.

Logwood.—Gives a brownish decoction. Acids render it yellow or reddish. Alcalies give it a splendid purple colour. If a drop of a solution of logwood and another of liquid ammonia are put on the same plate, but at a distance from each other, the vapour of the alkali very soon changes the colour of the logwood.

TWO LIMPID LIQUORS CONVERTED BY MIXTURE INTO A SOLID MASS.

Process 1. If a saturated solution of chloride of calcium be mixed with a saturated solution of carbonate of potash, both of which are transparent liquids, the result is the formation of an opaque and almost solid mass. Mutual decomposition of the salts takes place—chloride of potassium and carbonate of lime are formed; and the latter absorbs the whole of the water of solution, and produces a degree of solidity.



II.

Process 2. Drop sulphuric acid into a saturated solution of chloride of calcium; in this case also an opaque mass is produced.—The chloride of calcium is decomposed, and sulphate of lime, a highly insoluble salt, is formed.

Process 3. Pour a saturated solution of caustic potash into a saturated solution of sulphate of magnesia (Epsom salt), a nearly solid mass is produced. The sulphuric acid leaves the magnesia (which then combines with water and is precipitated in the form of a white powder) in order to combine with the potash.

If a little nitric acid be added to the product of *Process 1*, the solid mass will be converted into a transparent liquid: the insoluble carbonate of lime being converted into the soluble nitrate of lime.

A solid white powder produced by mixing two colourless liquids.—This is an effect of common occurrence in chemical experiments. See the article on *Precipitation*. The solids produced by the mixture of different liquids are of every variety of colour and form, and it is a very amusing and instructive exercise, to examine the effect of various precipitating agents on different metallic solutions. I shall add an example in the *test for muriatic acid*.—Add a drop of muriatic acid to a quart of water; pour some of the mixture into a test glass, and let fall into it a single drop of a solution of nitrate of silver—the whole will instantly be pervaded by a milkiness, because the chlorine of the muriatic acid combines with the silver and forms chloride of silver, a salt highly insoluble. So great is the power of this test, that if a single grain of common salt is dissolved in 42,250 grains of water, the muriatic acid is detected, though amounting to only 1 part in 108,333 of the weight of the solution.

A fluid produced by rubbing together two solid metals.—Triturate an amalgam of lead with an amalgam of bismuth—the product will be

fluid, like mercury. Fluids are likewise produced when any of the mixtures which follow are triturated; acetate of lead and sulphate of zinc—or, sulphate of soda and nitrate of ammonia—or sulphate of soda and carbonate of potash.—These salts should be all fresh crystallised.

A green coloured solid produced by mixing a blue one with a white one.—Triturate crystallised sulphate of copper with crystallised superacetate of lead. In this process, acetate of copper, which has a green colour, is formed.

To make a solid green paint by mixing a blue liquor with a colourless liquor.—Add to a hot solution of blue sulphate of copper, a little solution of colourless carbonate of soda—a beautiful powder, known by the name of French green, will be precipitated.—The powder is a subcarbonate of copper. The liquor may be separated by filtration.

Two pungent and invisible gases unite and form an inodorous solid.—*Process 1.* Fill a jar with ammoniacal gas, and another with muriatic acid gas, in the manner described in a subsequent part of this work. Apply the two jars mouth to mouth, and the above-mentioned effect will instantly be produced, chloride of ammonium being formed and precipitated on the sides of the jars.



12.

Process 2. Dip a clean feather into muriatic acid, and moisten with it the interior of a glass such as is depicted by fig. 12, and in like manner moisten the interior of a similar glass with liquid ammonia. The glasses, in this state, will seem empty, but if they be put mouth to mouth together, the whole included space will be filled with a dense white vapour; which in the end settles on the sides of the glasses in the form of a white powder, solid chloride of ammonium.

Process 3. If two jars, one containing ammoniacal gas, and the other containing carbonic acid gas, are thus put together, solid carbonate of ammonia will be formed.

Two highly-odorous liquids produce a mixture totally without odour.—Mix liquid ammonia with muriatic or nitric acid, till the resulting liquor is neutral. The smell of both the ingredients disappears, and the saline product has neither the acid nor the alkaline taste possessed by the two odorous liquids.

Two bodies devoid of odour produce a compound highly odorous and volatile.—Mingle together in a mortar equal parts of sal-ammoniac and quicklime. The mixture disengages ammoniacal gas, which has a very pungent odour.

To deprive a red rose of its colour, and to restore the colour again.—Hold a red rose over the blue flame produced by burning sulphur. You can do this by fastening the rose to the top of an inverted glass jar. This flame diffuses a gas which has the property of depriving vegetables of their colour. It is called sulphurous acid gas. Whenever it comes

into contact with the rose, the colour is so discharged as to make the rose either beautifully variegated or entirely white. If you afterwards dip the rose into water its red colour is restored to it.

A substance which may be eaten, produced by the admixture of two powerful poisons.—A solution of muriatic acid and a solution of caustic soda are both poisonous. If mixed together in such proportions as to make a neutral solution, they produce common kitchen salt.

The method of making such mixtures in proper proportions, is explained in the article on Equivalent Test Liquors.

Explanation.— $9\frac{1}{2}$ parts of muriatic acid contain 9 parts of chlorine and $\frac{1}{2}$ part of hydrogen. $10\frac{1}{2}$ parts of caustic soda contain 6 parts of sodium, 4 parts of oxygen, and $\frac{1}{2}$ part of hydrogen. When these quantities of the ingredients, in a state of aqueous solution, are mingled together, new combinations take place. 9 parts of chlorine and 6 parts of sodium, produce 15 parts of common salt, also called chloride of sodium; and 4 parts of oxygen and $\frac{1}{2}$ part of hydrogen, produce $4\frac{1}{2}$ parts of pure water. Thus nothing is lost or left at liberty. The chloride of sodium dissolves in the water at the moment of formation, but can be obtained in the state of crystals by evaporating the solution.

To Dissolve Metallic Copper in a Liquid.—Dissolve a grain of thin copper wire or foil in six drops of nitric acid, using a tube of the following form. Observe the effervescence that is produced; the pro-



13.

duction of red gas just above the liquor, the change of the liquor to green, the heat which is produced, the peculiar smell that is disengaged. In one minute the copper will be dissolved, the liquor remaining green. Blow into the tube by a smaller tube held in the mouth. This expels the red gas, and turns the green liquor blue. Alternately shake the tube and blow air into it, until the green colour and red gas no more return. The smell goes away with the gas. Look *into* the tube and not *across* it, to see the colour of the liquor and gas. Boil it next over a spirit lamp. White fumes of nitric acid go away. When the liquor gets thick and pasty, allow it to cool. It will form a mass of blue crystals, proceeding like rays from the centre. This is nitrate of copper. Apply heat; the crystals then melt, get drier, and stick about the sides of the glass as a hard cake. The salt now decomposes, and a strong smell of nitric acid is disengaged. When the bulb is cold, half fill it with water. Part of the hard matter dissolves, producing a blue solution of nitrate of copper; part remains undissolved as a bluish-green

powder. This is a nitrate with excess of base, which is insoluble in water. Add a single drop of nitric acid, and the whole will dissolve. With the resulting solution, you can apply the different tests for detecting copper, which are described under the head of Copper.

SYMPATHETIC INKS.

SYMPATHETIC inks are liquids which, being used for writing or drawing, form figures or letters, which, under certain circumstances, or after certain operations, become changed in colour, or from being illegible become conspicuous. Liquids of this kind known at present are very numerous, and the experiments executed with their assistance are some of the most entertaining which modern chemistry affords. Several varieties were known in very ancient times. We find Ovid teaching young women to deceive their guardians by writing billets to their lovers with new milk, letters formed with which are rendered legible by coal-dust or soot. And Ausonius proposes the same thing to Paulinus. Pliny, in whose time it was known that any colourless, glutinous juice would attract black powder as well as milk, recommends for this purpose the milky sap of certain plants.

There are several metallic solutions, entirely colourless, or having a very weak tint, which, if applied to paper, produce figures that remain invisible, either till washed with another colourless solution, or exposed to its vapour. Among these, there is none more curious or capable of exciting greater astonishment, than that which consists of a solution of sugar of lead, which becomes black on exposure to sulphuretted hydrogen gas, even at a considerable distance. The mountebank performers of mechanical tricks and chemical experiments, whom the people have been pleased to term conjurers, derive considerable aid from the service of bodies such as those under consideration. How potent must he appear to ignorant eyes, who causes a figure to grow, as it were, on a paper untouched by any hand, and exposed meanwhile to view! Yet, to do this, requires only that the person use the ink just named, and manage the business with a little dexterity.

Whatever is written with a solution of sugar of lead, with a clean pen, remains invisible while dry; but, when the writing is washed over with liquid sulphuretted hydrogen, it becomes instantly black. The most extraordinary circumstance is this, that, though sheets of paper without number, and even a board, be placed between the invisible writing and the reviving liquid, the same effect will take place as in the former case; the writing being turned black by a vapour which penetrates the substance of the wood and the folds of the paper.

It is instructive to look back upon the hypotheses which successive speculators set up to explain the causes of various effects observed in

ature. The phenomena which appeared to take place without any visible agency, were ascribed in the middle ages to certain "occult qualities." This doctrine gave way to the idea of magnetic effluvia, which was succeeded by a something termed sympathy; and sympathy itself was exploded by attraction and electricity. In future times our own method of tracing out causes will, no doubt, be reckoned as absurd as the ridiculous modes which have preceded it.

Another remarkable kind of sympathetic ink is that prepared from cobalt, the invention of which, though generally ascribed to Hellot, is affirmed by Pott to have been detailed by a German lady, very early in the seventeenth century. But it must be older than this, if it be true that, by means of this invention, Theophrastus Paracelsus could, in the same picture, represent alternately summer and winter. Such is the nature of this ink of cobalt, that the traces of it in writing or drawing are colourless when cold, but when moderately heated become of a beautiful green colour; which colour, however, vanishes as the paper cools, but can be made to reappear by a fresh application of heat.

I shall now mention a few of these inks out of the great number which but a slight acquaintance with chemistry will suggest to the student.—NOTE. The sympathetic inks may be laid on paper either with a camel-hair pencil or a common quill pen; but, whichever is used, it is necessary that the instrument be perfectly clean—the presence of the smallest quantity of any foreign body will go nigh to spoil the effect. The best thing to use is a clean fresh-cut quill pen.

1. Write with weak tincture of galls: the characters will be invisible. Moisten the paper with a feather, dipped in a weak solution of sulphate of iron—the writing will become black. To understand this phenomenon, you have only to know that a black liquid commonly termed ink is formed by adding infusion of galls to a solution of sulphate of iron.

2. Write with a weak solution of prussiate of potash—the letters will be invisible. Moisten the paper, as in the preceding experiment, with a weak solution of sulphate of iron—the writing will assume a fine *blue* colour.—*Rationale.* Prussian blue is here formed.

3. Wash paper with a solution of sulphate of iron, and suffer it to dry: when written upon this paper, dilute solution of prussiate of potash produces *blue* letters, and tincture of galls *black* ones; but upon common paper they make colourless marks.

4. Most acids, diluted and written with, leave marks which are invisible till the paper is heated, when they become *black*: the heat concentrating the weak acid, and enabling it to char the paper.

5. Write with a dilute solution of nitrate of silver, and let the writing dry *in the dark*—it will be invisible; fold up the paper so as to keep the writing in the dark—it will continue invisible; but, expose the writing to the light of the sun—it will become *black*.—*Rationale.* The

nitrate of silver has the property of being decomposed by light; a black colour being acquired by the metallic oxide.

6. Characters written with a solution of equal parts of sulphate of copper and sal-ammoniac, have a *yellow* colour when heated, but are invisible when cold.

7. Write with a dilute solution of chloride of copper. The writing is invisible when cold, but *yellow* when heated.

8. Write with a dilute solution of chloride of gold, and dry the writing in the dark—it will be invisible. Moisten the paper, by means of a feather or bit of sponge, with a solution of chloride of tin—the writing will then assume a purple colour, occasioned by the presence of a minute portion of the purple precipitate of Cassius, a compound of tin and gold.

9. Write with a solution of nitrate of bismuth—the writing will be invisible. Immerse the paper in water—the characters will then be legible.—*Rationale.* The water decomposes the salt, and causes a white compound of bismuth to be precipitated in a solid form.

10. Expose a paper upon which you have written with nitrate of bismuth, to the vapour of water impregnated with sulphuretted hydrogen—the writing will become black. It is the property of bismuth to be thus affected by sulphuretted hydrogen. The black substance is sulphide of bismuth.

11. Let a paper upon which you have written with nitrate of bismuth be moistened with solution of prussiate of potash the writing will assume a beautiful *yellow* colour; cyanide of bismuth being formed.

12. Write with a solution of sulphate of copper—no writing will be visible. Wash the paper with solution of prussiate of potash—the writing will then get a *reddish-brown* colour; cyanide of copper being formed.

13. Write with a solution of acetate of lead—the writing will be invisible. Hold the paper over a saucer containing liquid sulphuretted hydrogen—the writing will become, first black, and then glittering like silver. The metallic salt is here decomposed by the sulphuretted hydrogen, which produces black sulphide of lead.

14. Upon a fire-screen let there be drawn a representation of winter, with trees destitute of foliage, and ground covered with snow. Let, however, every part of the picture which, if the scene represented summer, would be green, be covered with the sympathetic ink, produced by dissolving zaffre or impure cobalt in aqua regia, which is a mixture of nitric and muriatic acids. Draw, for instance, leaves on the trees, and grass on the ground. These marks will not be visible; the picture will still bear the aspect of winter. But, let the fire-screen be placed for a short time near the fire, *then* the view will exhibit all the verdure of summer. When allowed to cool, the verdure disappears; but

it may be again revived, by the same means as before, and that as often as is desired, provided the paper be not heated beyond a certain point; for, if heated too much, the ink will assume a permanent brown colour. A solution of pure chloride of cobalt will not answer the above purpose, as it gives a blue and not a green sympathetic ink. The green tint is due to the presence of arsenic and iron among the impure cobalt.

15. A jar is filled with clear water. A piece of white pasteboard is put into it. The whole may be then covered from view. After a few minutes, the white pasteboard is taken out, and found to have an inscription upon it in blue letters. *Explanation*: The clear water is a weak solution of iodide of potassium, mixed with a few drops of sulphuric acid. The white pasteboard has had the writing previously made upon it with starch paste. Such writing is invisible on white pasteboard; but in the experiment, a blue compound is formed by the combination of iodine and starch.

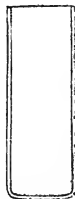

14.

My youthful readers will probably not take it amiss if I add here a few other examples of

CHEMISTRY FOR HOLIDAYS.

Such of them as visit the Polytechnic Institution, may like to know how they can imitate the wonderful exploits performed in that and similar establishments for public entertainment; some few of these popular experiments do not depend solely upon philosophical principles, but are aided in some degree by sleight of hand. It is not my business to teach the art of conjuring, but it is impossible to explain these experiments without describing the extent of the trickery which forms part of them.

The Enchanted Bottle.—The conjuror's bottle from which you pour when required, water, milk, blue dye, port wine, sherry, or champagne, is a popular experiment, akin to these depending on such chemical changes as have been described in the preceding section, but aided by a little trickery.

As the experiment is usually performed, the conjuror seems to pour from the same black bottle into different wine-glasses, all the above liquors in the order in which the audience demands them.

The bottle contains actually but one liquor, which is a solution of sulphate of iron, containing both protosulphate, and persulphate, and a little free sulphuric acid. This mixture is put into a black wine bottle, because it has a brown colour, which the audience ought not to see. The trickery is chiefly with the wine-glasses, in which are placed beforehand small quantities of such chemical reagents as suffice to produce the desired changes of colour. These reagents are as follow :—

For *water*, nothing. The slight colour of the liquor is not recognized in the wine-glass. For *milk*, a solution of chloride of calcium, or chloride of barium. For *blue dye*, solutions of red and yellow prussiate of potash mixed. For *port wine*, a solution of sulpho-cyanide of potassium. For *sherry*, a very small quantity of the same. For *champagne*, a solution of bicarbonate of soda.

All these solutions should be as strong as possible, the entire inside of the glass should be wetted with them, just before the experiment is performed, but there should be as little as possible of the reagents left in the glasses, and that should be hid by a finger of the hand that holds the glass. Duplicates of each prepared glass should be ready, in case a second glass of any one sort should be demanded by the company.

The volatile plum-pudding.—At dinner, when the cover is removed from the plum-pudding, the pudding leaves its dish and rises to the ceiling of the dining-room.

Explanation.—The pudding is a sham one, consisting of a globular balloon, about six inches in diameter, painted with spots like a plum-pudding, and filled with hydrogen gas. Under the head of HYDROGEN, I shall give full instructions for preparing the gas, and filling balloons.

Loaf-sugar contains charcoal.—Place a large test glass upon a plate.



15.

Half fill the glass with lumps of loaf-sugar and put over them as much hot water as will thoroughly moisten them. Then add about a quarter of a fluid ounce of oil of vitriol. The mixture soon smokes, becomes black, and froths up. You may stir it with a glass rod. It sometimes rises over the edge of the glass, which is the reason that you must put the glass in a plate or a stoneware pan.

When the effervescence is at an end, you may wash the black mass into a large glass jar, and stir it up with a pint of water. It will be seen to contain a quantity of black powder. Let this settle; then pour off the acid liquor, and wash the powder with fresh water. If the powder is then collected and washed on a filter in a funnel, and afterwards dried, it will be found to be charcoal. The method of proving it to be charcoal will be decided in a subsequent experiment (page 59). Sugar consists of carbon, oxygen, and hydrogen. The oil of vitriol converts the oxygen and hydrogen into water, and leaves the carbon (or charcoal) free, and this substance being insoluble, is easily separable from the liquid products of the decomposition.



16.

Cambric handkerchiefs and fine lace consist of charcoal and water.—The composition of cotton and linen is analogous to that of sugar. They contain carbon, oxygen, and hydrogen, and they can be decomposed, like sugar, by warm oil of vitriol.

Fix a porcelain capsule of about 3 inches in diameter on a retort

stand, fig. 17, and put into it about half a fluid ounce of strong sulphuric acid. Place a spirit lamp below it to warm it, but do not make it boil, because the boiling of sulphuric acid is a dangerous operation, and the acid for this experiment requires only to be gently warmed. Put into the acid some small pieces of calico or linen cloth, and stir them about with a six-inch glass rod. The cloth will very soon be decomposed by the acid, as the sugar was in the preceding experiment. A similar black mixture is produced, from which, by washing in a large quantity of water, and afterwards on a filter, the charcoal can be obtained in powder.

Vinegar is contained in dry wood.—If hard dry wood, oak, for example, or even a piece of dry cambric, is heated to redness in a glass tube closed at one end, in the manner described in a subsequent set of experiments on the identification of vegetable substances, the wood fibre will be decomposed, and a liquor will be expelled from it which contains vinegar, while charcoal in the solid form will remain behind in the glass tube. See pages 58 to 64.

A metal that takes fire when it touches cold water.—This is a property of the metal called potassium, which is extracted from the alkali potash. This metal is soft, lighter than water, and as brilliant as silver. It is preserved from the air in mineral naphtha, a liquid which contains no oxygen. A small globule, about a quarter of an inch in diameter, being thrown upon the surface of water contained in a flat pan of 9 to 12 inches diameter, immediately takes fire and burns with a violet-coloured flame and a hissing noise, swimming rapidly about the liquor and ending with a slight explosion. In this experiment, the potassium decomposes the water, sets free some hydrogen which burns with flame, and combines with the oxygen and part of the hydrogen to produce caustic potash, which dissolves in the water and renders it alkaline, as may be shown by means of red litmus test paper, which it turns blue.

A Fountain of Fire—formed by Phosphuretted Hydrogen Gas.—Put 15 grains of finely granulated zinc, and 6 grains of phosphorus, cut into small pieces under cold water, into a conical glass. Mix, in another glass, a drachm by measure of sulphuric acid, with two drachms of water. Now, take the two glasses into a dark room, and there pour the diluted acid over the zinc and phosphorus in the other glass: in a short time phosphuretted hydrogen gas will be produced, and beautiful jets of bluish flame will dart from all parts of the surface of the liquid, the mixture will be quite luminous, and a quantity of beautiful luminous smoke will rise in a column from the glass. *A Fountain of Fire* is a very apt name for the appearance that is produced. The experiment is very easily performed, and is a very beautiful one. But the operator must take care not to burn him-

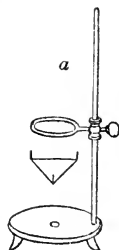

17.



18.

self. The phosphorus must always be kept in cold water. It must not be touched by the fingers unless when it is covered by cold water. Burns from it are painful and difficult to heal.

Coloured Flames.—Coloured alcohol flames are best produced by forming a wick of asbestos filaments, fixing it in a glass tube, and moistening it with the concentrated saline solution that is intended to communicate the colour to the burning alcohol. A cotton wick soaked in a strong solution of the salt can be also made use of. In either case the wick is to be put into a common glass spirit lamp, containing spirits of wine. The solutions which give a colour to flame are those of chloride of strontium, boracic acid, chloride of barium, nitrate and muriate of copper.

A stream of oxygen gas directed upon a spirit lamp, coloured in this manner, produces an intense coloured flame.

The Fire Cloud.—Mix 5 parts of chloride of strontium with 1 part of nitrate of copper. Saturate about a pint of alcohol or pyroxilic spirit with these mixed salts. Put this into a metallic fountain, condensing into it a quantity of air by a syringe. A small jet being affixed, the mixture is pressed out with considerable force. If allowed to play upon the roof of a room, and there kindled, a brilliant cloud of variegated fire is produced.

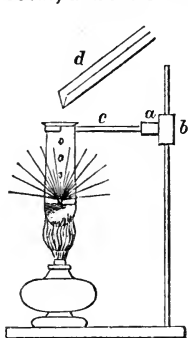

Brilliant Deflagration.—Use the apparatus shown in the following vignette. It consists of a thin hard Bohemian glass tube, 3 inches long and nearly 1 inch wide. It is supported by a narrow crook of tin-plate, *c*, fixed by means of a cork, *a*, into the sliding socket of a tube-holder, *b*. As much nitrate of potash is used as fills about half-an-inch of the tube when melted. The heat of a small spirit lamp is sufficient for this quantity. When the nitrate of potash is in fusion, remove the lamp, and put a basin of water below the tube: then, by means of a slip of tin-plate, *d*, pour into the tube a small quantity of well-dried charcoal powder. Remove your hand instantly:

a splendid combustion will occur in the tube. If the tube breaks, the contents fall into the water and do no harm.

In the same manner a small bit of sulphur, or of phosphorus, may be deflagrated. The latter should not exceed the eighth of an inch in diameter.

In these experiments, the combustible bodies combine energetically with the oxygen that is set free from the fused nitrate of potash.

The holiday amusements being over, we return to the philosophical consideration of our science.

EXAMPLES OF CHEMICAL OPERATIONS.

SOLUTION.

Take a two-ounce flat-bottomed solution bottle, fig. 19. Put into it a quarter of an ounce of alum in coarse powder. Add half an ounce, by measure, of water.¹

Light your spirit lamp. Push down the wick till the

flame is not above an inch long. If you use gas, make the flame of the same size. Hold the bottle with your right hand two or three inches above the flame. As soon as you see dew formed on the bottom of the bottle, wipe it with a dry cloth. Again hold the bottle over the flame, and again wipe off the dew. Move the bottle continually to keep the flame from heating one spot only, which would cause the bottle to break.



19.

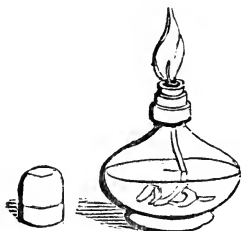

20.

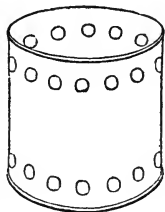

21.

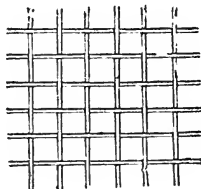

22.

Now place the stone-ware furnace cylinder round the lamp, to make the flame burn steadily. Put the wire trellis upon the top of the cylinder, and the bottle upon the trellis, exactly over the lamp. Lift the bottle occasionally, and gently shake it with a circular motion, to agitate the powder in the liquid.

¹ For the weighing of solids, you will require a set of small apothecaries' scales and weights. For measuring liquids, a glass measure graduated from a drachm to an ounce (eight drachms).



In a short time the water boils, and the alum disappears; that is to say, the water *dissolves* the alum. Extinguish the flame by putting on the cover of the lamp. Allow the solution to cool.

While it is cooling,¹ I will explain to you a few chemical terms relating to the operation of solution. A solid which thus disappears in a liquid is said to be *soluble* in it. The liquid in which it dissolves is called the *solvent* or *menstruum*. The resulting liquid is a *solution*. When the solution contains as great a quantity of the solid matter as it is capable of dissolving, it is *saturated*. A solution is *known* to be saturated when fresh solid matter of the same sort, on being put into it, *remains undissolved*. When a saturated solution is mixed with pure water, it is said to be *diluted*.

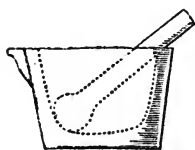

23.

Take a small porcelain mortar, two inches in diameter. Put into it a quarter of an ounce of kitchen salt. Half fill the mortar with water, and grind the salt in the water till the latter is saturated, which will be the case in a very few minutes. But if all the salt disappears during the grinding, you must add more to the same water, till you find the water to be saturated, and unable to dissolve any more salt.



24.

Allow the mixture to settle. Pour the clear part of it into a porcelain evaporating capsule of 3 inches diameter. Only half fill the capsule. Light your spirit lamp. Put round it the furnace cylinder. Place on the cylinder the perforated iron plate, fig. 25.

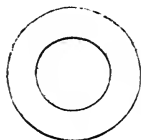

25.

Put the capsule in the perforation. Let all rest thus till the solution boils. Then put into the solution dry powdered kitchen salt, and see if it dissolves in the boiling solution. Watch the salt at the bottom to see if it diminishes in bulk, and watch also the solution at the top, to see if any change takes place there.

You will observe two results:—1st, That the additional salt does not dissolve;—2nd, That as the water of the solution diminishes by evaporation, the salt previously dissolved in it is reproduced in the solid form.

We now return to the solution of alum, which some time ago was left to cool.

If it is cold, you will find that a portion of the alum is deposited in it in the solid state.

We are enabled by these experiments to draw the following—

¹ The teacher is supposed to be dictating, and the students to be performing the experiments; hence the peculiar phraseology of this section.

Inferences respecting the Solubility of Alum and Salt.

a. Alum dissolves in larger quantity in hot water than it does in cold.

b. Kitchen salt dissolves equally well in hot water and cold water.

You perceive in this difference of solubility a chemical character whereby alum is distinguished from kitchen salt.

EVAPORATION.

It is necessary to prove to you that when a hot saturated solution of alum deposits a quantity of solid alum upon becoming cold, it does not deposit the whole of its alum.

Take a slip of window-glass an inch wide and six inches long. Hold this by one end in a flat position. Place upon it, near the other end, a drop of distilled water, so as to make a mark about half an inch in diameter, as I now show you, [see the mark *f* in the margin.]

Light your lamp, and warm the drop of water over the flame till it all flies off in steam. It will leave no solid residue.

Upon the same glass slip, put a similar drop of the clear liquor that rests above the solid alum in the solution bottle. Warm this drop over the lamp till the glass is again dry. You will observe that a solid white substance is left upon the glass where the drop of solution was warmed. This solid white substance is alum.

In the operation of solution, a solid is made to disappear in a liquid. In the operation just performed, the reverse is the case; for here a liquid is made to disappear by means of heat, and the solid that was dissolved in it resumes its visible form. This operation is termed *evaporation*.

PRECIPITATION.—TESTING.

You can prove by another experiment, that the supernatant liquor in the solution bottle contains alum.

Take a conical test-glass and a glass rod. Pour into the glass a few drops of the liquor from the solution bottle. Add to it *Liquid Ammonia*, a few drops at a time, and stir the mixture with a glass rod after each addition of ammonia. When, after being stirred, the liquor in the test-glass smells of ammonia, enough of the latter has been added.¹

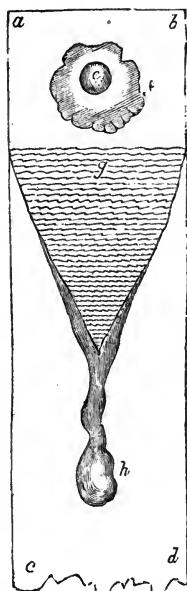

26.

¹ The young student must take care not to smell at ammonia incautiously, as it may produce much pain.

Observe that the effect produced by the addition of ammonia to the liquor presumed to contain alum, is the production of a solid substance having a white colour and a gelatinous consistence, which sinks slowly to the bottom of the test glass.

The substance thus produced is alumina, and its appearance proves that the clear liquor above the crystals still contains alum.

This application of any given chemical substance to prove the presence of another, by causing a particular phenomenon to take place, is termed *Testing*. The substance thus added is termed a *Test*, sometimes a *Reagent*. When the product happens to be, as it is in this case, a solid substance, the operation is called *precipitation*, the solid produced thus, a *precipitate*, and the liquid employed to produce it, a *precipitant*.

There is another test by which the presence of alum in the clear liquid can be made manifest by precipitation.

Take a conical test glass and a glass rod. Pour into the glass a few drops of the clear liquor resting above the crystals of alum in the solution bottle. Add to it a few drops of a clear solution of *Chloride of Barium*. Stir the mixture with the glass rod. You will observe that a white powder is produced. The chemical name of this powder is sulphate of barytes.

DISSOLVING POWER OF DIFFERENT LIQUIDS.

Take a test tube of the form I now show you, in size about six inches long, and half an inch wide. Fill an inch of it with water. Put into

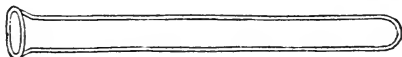

27.

it a piece of camphor the size of a pea. Light your spirit lamp. Hold the tube near the mouth, by the thumb and second finger of the right hand, close the mouth by the application of the forefinger. Hold the bottom of the tube about three inches above the flame of the lamp. Gradually bring it down till it touches the top of the flame. Keep it there for one minute.

The closing of the tube by the forefinger must take place *before* you apply heat. It is too late when the heat is applied. The use of it is to retain a certain quantity of air in the tube, above the liquid. This air becomes condensed at the top of the tube, by the steam that is produced, and keeps the tube cold enough to be held by the fingers. But if the forefinger is removed for an instant, the air escapes, hot steam rushes forth, and the tube is made too hot to be held.

The camphor will not dissolve in the hot water.

Pour off the water. Add to the camphor, as much strong spirit of wine as fills an inch of the tube, and again expose it to a boiling heat.

The camphor dissolves in the spirit of wine.

Add to the solution of camphor, in alcohol, twice its bulk of water. Close the mouth of the tube with the forefinger; shake the mixture; then let it settle.

You will observe that the camphor is precipitated, that is to say, is reproduced in the solid state.

Hence camphor is insoluble in water, soluble in alcohol, but insoluble in diluted alcohol.

Take a similar test tube. Put into it half the bulk of a pea of pounded alum. Fill half an inch of the tube with alcohol. Boil the mixture over the spirit lamp.

You will find that the alum will not dissolve.

Yet you found that alum dissolved readily in water.

Here, then, is a chemical difference between alum and camphor, in respect to solubility. Alum dissolves in water, but not in alcohol. Camphor dissolves in alcohol, but not in water.

You will observe that these experiments show it to be necessary, in speaking of the solubility of a substance, to name the liquid in which it is soluble; and in speaking of its solubility in any particular quantity of the liquid, to name at what temperature the solution is effected, whether at the usual temperature of the air, or at a boiling heat.

CRYSTALLISATION.

Take a flat glass plate. Put upon one end of it a drop, as large as a sixpence, of the saturated solution of kitchen salt, prepared in a former experiment (p. 50). Light your spirit lamp. Hold the drop of solution over the flame till the edges of the drop begin to look white and dry, then remove it from the flame and let it cool.

You will observe, that in proportion as the water flies off in steam, the kitchen salt resumes the solid state, in the form of *cubes* or *dice*.

Take another glass plate. Put upon it a drop of the liquor produced by cooling the hot solution of alum, prepared in a former experiment (p. 49). Boil this drop of solution for an instant over the spirit lamp, then remove it and let it cool.

You will observe that the salt will be deposited in the solid state, in the form of square and triangular pyramids, larger in size than the little dice deposited by the kitchen salt.

Take a bit of nitre, the eighth part of an inch in diameter. Powder it, and put it on the end of a flat glass plate. Add a drop of water, sufficient to spread as wide as a sixpence, over the nitre. [See letters *e* and *f* in the figure in p. 51.] Apply below it the flame of a spirit lamp. The nitre will soon dissolve and form a solution. Retain the solution in a moderate heat till it begins to look dry at the edges. Then remove it from the flame and let it cool.

You will observe that the salt will be deposited, in this case, under a

form, differing both from that of the kitchen salt and of the alum. It will appear like many masses of fibres, all radiating from centres, as do the spokes of a wheel, or the bones of a lady's fan.

I recommend you to repeat these experiments at your leisure, upon larger quantities of the three salts; and for this purpose, I shall give you the following directions:—

CRYSTALLISATION OF KITCHEN SALT.—Take half an ounce of kitchen salt. Dissolve it in water, by grinding it with water in a porcelain mortar, as was done in a former experiment (p. 50). Pour the solution from the mortar into a glass tumbler, and let any solid matter settle to the bottom. Then pour the clear solution into a porcelain capsule of 4 inches diameter. Light a small oil lamp,¹ containing sweet oil, and with the wick cut so short, that it burns without smoking. Put the furnace cylinder around the lamp, and the perforated iron plate upon the cylinder; fix the capsule in the perforation.

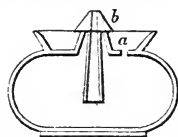

28.

The flame of the lamp should not be much more than half an inch long, otherwise the heat will be too strong, and the evaporation too rapid. The object to be gained, is to evaporate the water continually, but slowly.

Kitchen salt being equally soluble in hot and cold water, it can only be separated from its solutions by the evaporation of its water. The slower this evaporation takes place, the larger and the more complete in their form are the solid pieces of salt, the *dice* before spoken, which are produced in the course of the process. The solid pieces of determinate form thus produced in aqueous solutions, in consequence of the abstraction of part of the water, are in chemical language termed *crystals*. They are geometrical figures, possessing a certain number of plane surfaces, and consequently a certain number of edges and angles. The form which is assumed by kitchen salt, when slowly separated from its solution, is that of the *dice* or *cube* which I now show you.



29.

¹ The above figure represents a stoneware oil lamp, useful for slow evaporations. *b* represents the wick-holder. At the upper part is a cup for collecting the oil that overflows during the combustion, and for returning it, by the hole *a*, into the lamp.

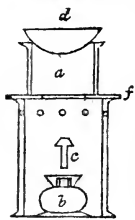

30.

The annexed figure exhibits a mode of effecting a slow evaporation: *b* is the lamp, *c* the wick-holder shown apart, *f* the perforated iron-plate, resting on the lamp cylinder, and supporting an extra stoneware cylinder *a*. The capsule containing the solution to be evaporated is marked *d*.

CRYSTALLISATION OF ALUM.—In the same manner as directed in the preceding article, prepare and evaporate a solution of half an ounce of alum. Be again careful to evaporate slowly, and do not allow the solution to boil. When the evaporation has been carried so far that a thin film, or skin, begins to appear on the surface of the solution, you are to remove the capsule from the lamp, and set it aside upon a thick woollen cloth or cushion to cool.

The film which appears upon a solution when undergoing concentration by evaporation, marks the stage at which the hot liquor is perfectly saturated with the salt, and at which, if deprived of any more of its water, it will begin to deposit a corresponding quantity of its salt. At such a stage, if the solution contains a salt less soluble in cold water than in hot, it will, if allowed to cool slowly, deposit in crystals a quantity of salt equivalent to the reduction of temperature, and these crystals will be the more perfect in proportion to the slowness with which the cooling is permitted to take place. Now, alum is a substance of this character, and if its solution is brought to a proper state of concentration, and permitted to cool with a proper degree of slowness, it will produce crystals bearing a resemblance to the figure which

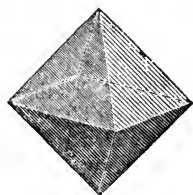

31.

I now show you—a figure not unlike two Egyptian pyramids joined base to base, and which in scientific language is called an *octahedron*. It is an approximation, more or less near, to this form, which produces the little square and triangular pyramids which appear when a drop of solution of alum is evaporated upon a slip of glass (p. 53).

You find, therefore, in the result afforded by the careful crystallisation of alum and kitchen salt, another character which serves to distinguish these two substances from one another. Namely, that whereas the faces of the crystals of alum are triangular, those of the crystals of kitchen salt are square; and that whereas a perfect crystal of alum possesses *eight faces*, a perfect crystal of kitchen salt possesses only *six*. The first is an octahedron, the last a cube.

I showed you that when a hot solution of alum was cooled, a certain quantity of alum was deposited, but not all that the water held in solution. This is a constant result in similar operations. The liquor left above a mass of crystals produced by concentrating or by cooling a hot solution, is, in all cases, still a cold saturated solution of the salt in question; for only so much of the salt separates in crystals from the cooling liquid as cannot be held in solution at the diminished temperature. Consequently, on pouring off the liquor from a mass of crystals, and again subjecting it to evaporation and to cooling, a second crop of crystals can be procured from it. And by carrying as far as possible this alternate heating and cooling of the solution, you may separate in

crystals nearly the whole quantity of the salt held in solution. The technical term for a liquid poured off from a deposit of crystals, is the *mother-liquor*.

By the solution, evaporation, and crystallisation of half an ounce of nitre, performed exactly in the same manner as the last experiment with alum, you will obtain crystals of nitre in long *six-sided prisms*.

A similar experiment made with *sulphate of soda* will produce crystals that are *four-sided prisms*.

The evaporation of a drop of the solution of sulphate of soda upon a flat glass plate, readily produces four-sided prisms, mostly so very flat as to resemble knife-blades. In general they are radiated, but not in so decided a manner as the crystals of nitre described in a former experiment.

EFFLORESCENCE.

If you dry the crystals of sulphate of soda on the glass plate by pressing a bit of paper upon them, and then expose them on the glass to dry air for an hour, you will find that they will lose their transparency, turn white, and fall to powder. This phenomenon is called *efflorescence*. It occurs when crystals which contain water of crystallisation readily part with it to dry air. Most of the salts of soda are of this kind.

DELIQUESCENCE.

Take half an ounce each of dry carbonate of potash and crystallised carbonate of soda, both in fine powder. Expose them in two separate weighed porcelain capsules to the free air for at least a day; then weigh them again. The carbonate of soda will be found to have *lost weight*. The carbonate of potash to have *gained weight*. The air of the atmosphere takes water *from* the carbonate of soda, or, as it is said, causes it to *effloresce*; but it gives water *to* the carbonate of potash, or causes it to *deliquesce*. Deliquescent salts are difficult to crystallise and easy to dissolve.

EFFERVESCENCE.



32.

Take a conical test glass. Half fill it with water. Put into it two pieces as big as a pea of chalk or of carbonate of soda. Then add a few drops of muriatic acid. You will immediately observe a sort of boiling up, which in chemical language is termed *effervescence*. This effect is produced by the production, and escape through the water, of a quantity of gas.

If you perform this experiment with larger quantities of materials than is mentioned here, it is proper to place the conical glass in the middle of a flat-bottomed glass capsule. In that case, when the acid boils over, it does not soil the table.



33.

SUBLIMATION.

Sublimation is a process by which volatile substances are converted by heat into vapours, and by the withdrawal of heat again condensed into solids. In small experiments undertaken to prove that a substance will sublime when heated in close vessels, or that, when it sublimes, it produces a particular kind of vapour, as respects its colour or smell, or that it produces crystals: or in experiments made to ascertain whether a substance is volatile or not, or whether or not it can be converted into a volatile substance; in these, and many other analytical cases of sublimation, it is now common to use no other apparatus than a glass tube closed at one end, and formed of very infusible glass. The substance to be sublimed is placed at the bottom of the tube, and is then exposed to heat. The sublimate, if any is produced, condenses upon the upper part of the tube, and is there examined. The quantity of matter taken for such an experiment need not in general be more than will lie upon this figure.

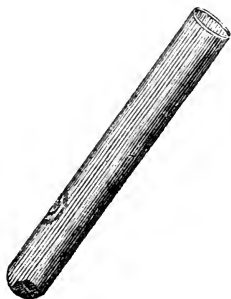

34.



35.

These general directions will enable you to comprehend readily the following experiments:—

1. Spread a small quantity of grossly-powdered gum-benzoin on the bottom of a porcelain basin, invert over it a glass tumbler, and apply to it a gentle heat by means of the lamp-furnace: the gum will melt, and dense fumes will immediately rise from it and deposit themselves on the sides of the glass in beautiful silky crystals of benzoic acid.

2. Take a large glass jar, containing at its top a sprig of rosemary or some such shrub, and invert it over a flat thick piece of heated iron on which coarse powder of gum-benzoin has just been spread—then, the benzoic acid which rises, as in the preceding experiment, will be deposited on the branches of the shrub, producing a singular and beautiful representation of hoar frost.

3. Put a little camphor on a tin plate. Invert a conical test glass over it. Apply the heat of a spirit lamp below. The camphor readily sublimes.

4. Put a grain of iodine into a small flask, or glass tube, and apply heat. Splendid violet vapours of iodine soon fill the tube. When the sublimation of iodine is effected slowly, crystals are formed.

5. Sublime a grain of cinnabar in a tube one-third of an inch wide.



36.



37.

6. Sublime a grain of calomel in a similar tube. These two mercurial compounds will be found to be less easily volatilized than camphor, iodine, benzoic acid, and some other substances.

7. Put a grain of red oxide of mercury into a very small glass tube, and apply heat till the red oxide is entirely volatilized. Metallic mercury will condense on the sides of the tube, and oxygen gas escape at the mouth.

DISCRIMINATION OF VEGETABLE, ANIMAL, AND MINERAL BODIES.

A.—SOME OF THE PROPERTIES OF NITRATE OF POTASH, AS DISTINGUISHED FROM CARBONATE OF POTASH.

Prepare the nitrate of potash as follows:—Take a test spoonful¹ of it in powder. Put it into a test tube half an inch wide by 3 or 4 inches long; add two drachms of water, and apply heat by means of the spirit



38.

lamp. If the solution thus produced is turbid, filter it through a small paper filter, supported in a filter ring laid on a beaked tumbler. The filter is not to be washed, nor the solution to be diluted.

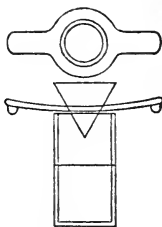

41.

1. Put a few drops of the solution of nitrate of potash into a conical test glass. Add two or three drops of nitric acid. There will be no effervescence, and no visible change.



40.

2. Put into a similar conical test glass, a few drops of a concentrated solution of carbonate of potash. Add two or three drops of nitric acid. There will be a strong effervescence, and a discharge of colourless inodorous carbonic acid gas.



39.

¹ The test spoon is made of German silver. The bowl of it is hemispherical, and about a quarter of an inch in diameter. A *test spoonful* is as much of anything as can be conveniently lifted and carried in this spoon without spilling any of it. I use this term instead of the more indefinite term, a "*small quantity*." The handle of the test spoon is formed into a spatula, and serves for mixing powders with fluxes, in blowpipe experiments, &c.

3. Put a few drops of the solution of nitrate of potash into a conical test glass. Add two or three drops of a solution of nitrate of lime. Stir the mixture with a glass rod. No change will take place.

4. Put into a similar conical test glass a few drops of a solution of carbonate of potash. Add two or three drops of a solution of nitrate of lime. Stir the mixture with a glass rod. An abundant *white precipitate* will appear. Add a few drops of nitric acid, and again stir the mixture. The white precipitate will effervesce and disappear.

5. *Results of this Experiment.*—The student is furnished with a process by which he can always distinguish *carbonate* of potash from *nitrate* of potash. The use of this will be shown presently.

B.—SOME OF THE PROPERTIES OF CHARCOAL.

Light your spirit lamp. Take a bulb glass tube of this size: [represented by the engraving, fig. 42.] Hold it by the open end. Warm it over the flame to dry it. Take a piece of charcoal the size of a pea, that is to say, a ball of a quarter of an inch in diameter. Put it

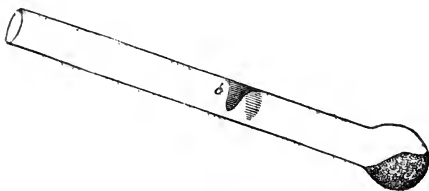

42.

into the tube. Hold the tube with the thumb and middle finger of the right hand in a horizontal position, or nearly so. Close the mouth of it with your forefinger, and heat the bulb over the flame till the charcoal becomes red hot.

1. Now observe,

That water appears upon the inner sides of the neck of the tube.

That the charcoal remains apparently unaltered.

2. Push a narrow slip of blue litmus test paper into the tube so as to become wetted by the water.

Do the same with a slip of red litmus or of yellow turmeric test paper.

Observe that the water expelled by heat from charcoal produces no change in these vegetable colours. It is, in fact, merely hygroscopic moisture, and is neither acid nor alkaline.

3. Take a small thin porcelain cup one inch in diameter, and fix it

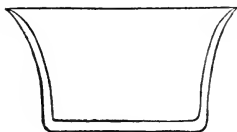

43.

upon a thin wire triangle over the flame of a spirit lamp. Instead of the porcelain cup, you may use a very short glass tube closed at the bottom, or still better, a platinum cup one-third of an inch or half an inch in diameter. If the latter has a handle, it may be held by means of the small tongs, p. 61. If not it may be supported on a very thin iron triangle.¹



44.

Into this vessel put a test spoonful of nitrate of potash. Light the lamp and bring the nitrate of potash into full fusion. Then, without removing the flame, add to the melted nitre a few pieces, each as big as a pin's head, of the charcoal that was previously heated in the glass tube. You will observe that **DEFLAGRATION** takes place, that is to say, explosion accompanied by fire, within the cup; and that the charcoal swims about red hot on the nitre, and finally disappears.

4. When the porcelain cup is become nearly cold, half fill it with water, and boil the water to produce a solution of the substance, afforded by the deflagration of the charcoal in the nitre. If you use a platinum cup, it can be put into a glass tube and boiled with the water. Filter the resulting solution in the manner described at Exp. A, page 58.

5. Put a few drops of this solution into a conical test glass. Add two or three drops of nitric acid. There will be a strong effervescence.

6. Put a few drops of the solution into a conical test glass. Add two or three drops of a solution of nitrate of lime. There will be a white precipitate. Add to this two or three drops of nitric acid, and stir the mixture with a glass rod. The precipitate now dissolves with effervescence.

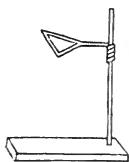

45.

¹ The fixing of the cup at a proper distance above the flame, is effected by means of the *retort holder*, which consists of a perpendicular metal rod, a wooden foot, and a horizontal arm of thin brass wire, terminated at one end by a triangle, and at the other by a coil, which runs on the perpendicular rod, and which can be fixed at any height above the foot, by simple pressure upon the triangle. The size of the triangle can be diminished by smaller triangles of very fine wire, bent as I now show you (fig. 46), and placed across the larger triangle.

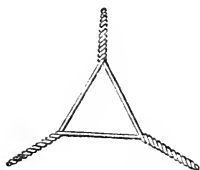

46.

The porcelain cup can also be fixed above the spirit lamp by means of the cylinder of the lamp furnace. A flat iron top is put on the cylinder, and a fine iron triangle placed upon it. The cup is then fixed in the triangle.

7. Support a splinter of the same charcoal before the flame of the blowpipe,¹ or near the edge of the spirit lamp; holding it on a piece of platinum foil, or in a platinum cup held spoon-fashion by means of the platinum tongs.



47.

Observe that the charcoal burns without flame, gradually diminishes in size, and finally disappears, except a very small quantity of a white incombustible ash.

Result.—Experiments B, 3 to 6, in conjunction with Experiments A, 1 to 5, prove that the deflagration of nitre with charcoal changes NITRATE of Potash into CARBONATE of Potash.

C.—NATURE OF VEGETABLE BODIES.

1. Take a piece of dry writing paper an inch square. Crush it up into a lump the size of a pea. Put it into a glass tube, such as that in

¹ The sort of blowpipe to be used in these experiments is represented in the following figure. For instructions as to the method of

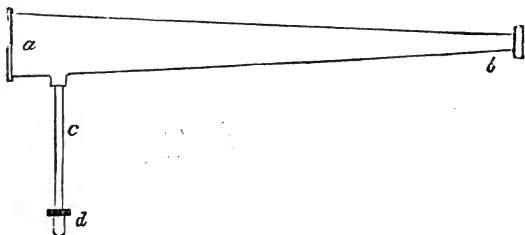

48.

using it, I refer you to my "*Treatise on Chemical Manipulation,*" wherein I have treated comprehensively of the use of this instrument.

I make no apology for introducing the use of the blowpipe thus early into an elementary course of experiments, because I am persuaded that such a course cannot be carried on cheaply and conveniently unless the blowpipe is made to replace the furnace as often as possible. Besides, there is no reason why the use of this instrument ought to be deferred. The presumed difficulty of learning to use it is quite imaginary, as I do not doubt it will be found by all who take the trouble to consult the work to which I have referred.

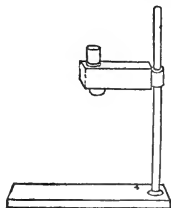

49.

The lamp used for experiments with the blowpipe is represented in the margin (fig. 49).

which you ignited the piece of charcoal, Exp. B. Take a slip of blue litmus test paper, and a slip of yellow turmeric test paper, and slightly moisten both of them with clean water, by means of the water bottle, page 31. Now ignite the piece of paper by holding the bulb of the tube in the flame of the spirit lamp. As soon as you see a white smoke in the tube, dip into it the blue test paper. After a moment take out the blue paper and put in the yellow paper.

2. Observe, that the white paper heated in the tube is converted into a black substance, preserving the same size and shape.

3. That a brown oily liquid is deposited on the sides of the tube.

4. That the blue test paper turns red, and that the yellow test paper remains unchanged, in the volatile matter given off during the ignition.

5. Fix a porcelain cup, by means of a wire triangle, over the spirit lamp. Melt in it three grains of nitre. Throw into the hot melted nitre, part of the black substance produced by the charring of the paper in the tube.

6. Observe that deflagration is produced, and that the black substance, after swimming about in the nitre red hot, finally disappears, precisely as the charcoal was observed to do in Exp. B, 3.

7. Boil water in the porcelain cup to dissolve the salt produced by the deflagration. Filter the solution without diluting it, and divide it into two portions in conical test glasses.

8. Add to one portion a few drops of nitric acid, which will occasion an effervescence.

9. Add to the other portion a few drops of a solution of nitrate of lime, which will produce a white precipitate; then add a few drops of nitric acid, and stir the mixture with a glass rod, whereupon the white precipitate will effervesce and re-dissolve.

10. Support the remainder of the black substance before the blow-pipe flame. Hold it upon platinum foil, or in the platinum cup. See B, 7.

11. Observe that it burns away without flame, and leaves nothing but a very small quantity of incombustible white ashes.

Inferences respecting the Nature of Vegetable Bodies, as exemplified by these experiments on paper.

a. They contain charcoal. The proof of this fact is afforded by the properties of the mixed black substance which is left when the paper is ignited in close vessels.

b. They contain the elements of a volatile acid, which acid they produce when subjected to the red heat in close vessels. This acid is vinegar.

This experiment will also enable you to understand the nature of the process by which vinegar is made from wood. Large iron vessels, fixed in a furnace, are filled with wood, and then shut close, with the excep-

tion of a pipe that is fixed into each of them. The fire is then lighted in the furnace, and the iron vessels are made red hot. Vinegar issues from the pipes, and when it is all passed out, the iron vessels are opened, and the wood is found to be converted into charcoal.

The vinegar thus produced is not in a pure state, but is mixed with the brown oily liquid that you found to condense on the sides of the glass tube during the ignition of the paper. It is freed from this liquid by subsequent operations.

D.—NATURE OF ANIMAL BODIES.

1. Take a dried cochineal insect, or a bit of a feather. Put it into a glass tube. Prepare moistened slips of blue and yellow test papers. Ignite the insect by holding the tube in the flame of the spirit lamp, and put into the tube during the ignition, first the blue test paper, and then the yellow test paper. The ignition need not last longer than one minute.

2. Observe that the ignited insect is converted into a black substance like charcoal.

3. That a brown oily liquid is deposited on the sides of the tube.

4. That there is a strong smell of burnt oil and hartshorn.

5. That the blue test paper remains unaltered, and the yellow test paper turns brown.

6. Fix a porcelain cup upon the wire triangle over the spirit lamp. Melt in it three grains of nitre. Throw into the melted nitre part of the black substance produced by the ignition of the cochineal.

Observe that deflagration is produced, and that the black substance disappears.

7. The product of the deflagration, if dissolved and filtered will be found, by the process formerly given, section C, Nos. 7, 8, 9, to contain carbonate of potash.

8. Hold the rest of the black substance in the platinum spoon before the blowpipe flame.

Observe that it burns away without flame, and leaves only a very small quantity of white ashes.

9. *Inferences respecting the Nature of Animal Bodies, as exemplified by the cochineal insect.*

a. They contain charcoal.

b. They contain the elements of a volatile alkali, which alkali they produce when subjected to a red heat in close vessels.

These experiments enable you to understand the nature of the process by which *spirits of hartshorn* is made.

Hartshorn, or more commonly the bones of animals, is ignited in iron vessels, shut quite close, with the exception of a pipe to carry off gases. What passes out of the vessels during the ignition, is the volatile alkali, ammonia, in company with the brown oil which in your

experiment is deposited on the sides of the glass tube. Spirits of hartshorn is just such a mixture. The volatile alkali, ammonia, is spirits of hartshorn deprived of its brown oil.

The fetid smell produced in your experiment, arises not so much from the alkali, as from the brown oil, which contains a variety of odorous compounds.

The fixed matter that remains in the iron vessels, after this operation, is of a black colour. It is ground into powder, and sold under the name of *bone black*, or *animal charcoal*. When ignited in the open air, this black substance burns away partly, and leaves a white residue, commonly called *bone ash*. The part that burns away is charcoal. The white residue is phosphate of lime. This is the solid matter of all bones, but is not a component part of flesh.

E.—I do not intend to pursue the Analysis of Organic Bodies any farther; but the following facts I beg you to bear in recollection:—

1. A substance that gives off volatile matter when ignited in a glass tube, and leaves a charred residue that deflagrates with melted nitre, is almost invariably of organic origin.

2. If the volatile matter disengaged during the ignition turns blue litmus red, the substance is almost always of vegetable origin.

3. If the volatile matter turns yellow turmeric brown, the substance is almost always of animal origin, or if not so, it is one of those vegetable bodies that contain nitrogen.

4. A substance that does not char when ignited in a glass tube, nor give off volatile matter, nor deflagrate with melted nitre, is certainly derived from the mineral kingdom.

5. If a substance chars in a tube, gives off volatile matter, and affords a residue that deflagrates with nitre, yet will not burn entirely away when heated in a platinum cup in free air, then it consists partly of an *organic*, and partly of an *inorganic* substance; as, for example, of a vegetable acid combined with an earth, or of a metallic acid combined with a vegetable alkali.

6. Several mineral bodies give off water in the tube, or turn black when heated, or deflagrate with nitre, or burn entirely away in the open air; but no single mineral substance can exhibit all the phenomena which have been described, as characteristic of organic bodies.¹

¹ *Substances to be given as Exercises on this Experiment.*—The teacher may give the student small quantities of some of the following substances for examination according to this process. Alum, salt, chalk, red lead, starch, ground rice, gum kino, peroxide of manganese, pounded charcoal, sulphur, acetate of lead, fibres of asbestos, fibres of cotton, fibres of silk, acetate of copper, with any kind of dried vegetable or animal substance.

QUALITATIVE ANALYSIS OF SALTS.

I PROPOSE to give in this section a COURSE OF TESTING adapted for beginners. The course may be followed by a single student, using the book as his guide; but the experiments are such as can also be performed by a large number of students, each provided with a set of apparatus, and all working simultaneously, under the direction of a teacher.

The object proposed is to analyse a certain number of the compound bodies termed Salts, embracing those of the most important Acids, Alcalies, Earths, and Metals; and in order that the solution of the problem may not be rendered too difficult, only such salts are to be taken as will dissolve in water.

SUBSTANCES TO BE SOUGHT FOR.¹

The instructions now to be given apply only to compounds which *dissolve in water*, and which *contain no other metals*, and *salts of no other acids*, than those I am about to name:—

These METALS—

1. Potassium.	12. Zinc.	21. Nickel.
2. Sodium.	13. Tin, protosalts.	22. Chromium.
3. Ammonium.	14. Aluminum.	23. Iron,
4. Barium.	15. Lead.	mixtures of
5. Strontium.	16. Tin, persalts.	persalts with
6. Calcium.	17. Antimony.	protosalts.
7. Manganese.	18. Mercury, proto-	24. Mercury, persalts.
8. Iron, protosalts.	salts.	25. Gold.
9. Magnesium.	19. Cobalt.	26. Iron, persalts.
10. Cadmium.	20. Copper.	27. Silver.
11. Bismuth.		

And these CLASSES OF SALTS—

1. Nitrates.	6. Sulphides.	11. Oxalates.
2. Chlorates.	7. Fluorides.	12. Carbonates.
3. Chlorides.	8. Phosphates.	13. Sulphates.
4. Iodides.	9. Arseniates.	14. Chromates.
5. Arsenites.	10. Borates.	

¹ From this point the text may be read as instructions to those who are to make the experiments.

Any single salt, soluble in water, and containing one of these 27 metals and one of the acids of these 14 classes of salts, can be analysed by the method now to be described.¹

¹ The teacher who gives out the salt to be examined takes care that these conditions are fulfilled, that the salt is pure, and that it contains no other substances than those I have enumerated.

Free acids and bases should not be given to pupils until they have had some experience in the testing of salts; because, in many cases, they do not, until neutralized, act towards the reagents in the same manner as their respective salts. And when they are for the first time given to the pupils, notice should also be given that free acids and bases may be found among the substances given for analysis.

LIST OF THE APPARATUS REQUIRED BY EACH STUDENT FOR THIS SET OF EXPERIMENTS.

a. APPARATUS FOR INDICATING TESTS.

Small porcelain pestle and mortar.	Water bottle to supply water to tubes.
Test spoon (German silver).	Glass funnel and support.
Flat-bottomed flask, to hold 1 or 2 ounces of water.	2 straight pipettes, small size.
Pipette graduated to 25 septems.	8 conical test glasses with spout.
Glass spirit lamp.	8 glass stirrers, 3 inch.
Cotton wick for lamp in a box.	Rest for stirrers and pipettes.
Small brass tongs to trim the wick.	Boiling tube, 6 inches by 1 inch.
Lamp furnace cylinder with holes.	Handle to hold the boiling tube while hot.
Trellis top for lamp furnace.	Book of red litmus test paper.
Box with 100 circular filters $2\frac{3}{4}$ inches diameter.	Book of blue litmus test paper.
Filter-ring to hold the filter over a test glass.	Pair of tubes for testing with sulphuretted hydrogen.
9 capped bottles with pipettes (fig. 6, p. 33), about 2 oz. size, containing solutions of the following tests:—	
Carbonate of Soda.	Nitrate of Silver.
Liquid Ammonia.	Nitrate of Lead.
Caustic Potash.	Chloride of Calcium.
Red Prussiate of Potash.	Nitric Acid.
Nitrate of Barytes.	
2 wide-mouthed stoppered bottles with the following dry tests:—	
Sulphide of Calcium.	Bisulphate of Potash.

b. APPARATUS FOR CONFIRMING TESTS.—See page 83.

That you may have an idea of the compounds with which you must expect to meet, I now show you a list of salts, acids, and bases, that may be presented to you for analysis.

NITRATE OF	CHLORIDE OF	FLUORIDE OF	SULPHATE OF
1. Potash.	31. Calcium.	59. Potassium.	87. Chromium.
2. Soda.	32. Manganese.	60. Silver.	88. Iron, per- and proto- salts mixed.
3. Ammonia.	33. Iron, proto.		89. Iron, perox.
4. Barytes.	34. Magnesium.	PHOSPHATE OF	
5. Strontian.	35. Cadmium.	61. Soda.	
6. Lime.	36. Bismuth.	62. Ammonia.	CHROMATE OF
7. Magnesia.	37. Zinc.		90. Potash.
8. Cadmium.	38. Tin, proto.	ARSENIATE OF	91. Soda.
9. Bismuth.	39. Aluminum.	63. Potash.	
10. Zinc.	40. Tin, perch.	64. Soda.	FREE BASES, <i>soluble in water.</i>
11. Tin, prot- oxide.	41. Antimony.		92. Potash.
12. Alumina.	42. Cobalt.	BORATE OF	93. Soda.
13. Lead.	43. Copper.	65. Potash.	94. Ammonia.
14. Tin, per- oxide.	44. Nickel.	66. Soda.	95. Barytes.
15. Mercury, protoxide.	45. Chromium.	67. Ammonia.	96. Strontian.
16. Cobalt.	46. Iron, mixed per- and pro- tochloride.	OXALATE OF	97. Lime.
17. Copper.	47. Mercury, perchloride.	68. Potash.	
18. Nickel.	48. Gold.	69. Soda.	FREE ACIDS <i>in aqueous solution.</i>
19. Chromium.	49. Iron, perch.	70. Ammonia.	98. Nitric.
20. Mercury, peroxide.			99. Chloric.
21. Silver.	IODIDE OF	CARBONATE OF	100. Muriatic.
	50. Potassium.	71. Potash.	101. Hydriodic.
CHLORATE OF	51. Sodium.	72. Soda.	102. Arsenious.
22. Potash.		73. Ammonia.	103. Sulphuret- ted Hydro- gen.
23. Barytes.	ARSENITE OF	SULPHATE OF	104. Hydro- fluoric.
24. Lime.	52. Potash.	74. Potash.	105. Phosphoric.
25. Silver.	53. Soda.	75. Soda.	106. Arsenic.
		76. Ammonia.	107. Boracic.
CHLORIDE OF	SULPHIDE OF	77. Manganese.	108. Oxalic.
26. Potassium.	54. Potassium.	78. Iron, proto.	109. Carbonic.
27. Sodium.	55. Sodium.	79. Magnesia.	110. Sulphuric.
28. Ammonium.	56. Ammonium.	80. Cadmium.	111. Chromic.
29. Barium.	57. Barium.	81. Bismuth.	
30. Strontium.	58. Calcium.	82. Zinc.	
		83. Alumina.	
		84. Cobalt.	
		85. Copper.	
		86. Nickel.	

PREPARATION OF A SOLUTION OF THE SALT.

You are now supposed to be furnished with a set of testing apparatus, with reagents, and with a salt intended to be analysed.¹ You are therefore ready to proceed.

The first thing you have to do is to make a *solution* of part of the substance for analysis.

Pulverize your salt in the small porcelain mortar, till it feels no longer gritty between the finger and thumb. Put the half of the powder upon the end of a slip of glazed writing-paper, and insert it, as I now show you,² into a one-ounce or two-ounce flat-bottomed solution flask. Next, pour into the graduated measure one drachm of water. Add this to the powder in the flask. Be sure not to spill any of the water on the outside of your flask, or if you *do* spill it, be sure and wipe the flask dry.

¹ *Advertisement to Teachers.*—The quantity of dry salt supplied for the first experiment may be 10 grains to each pupil; one half to be used in forming a solution for examination by the Indicating Tests; the other half to be kept in the solid state for examination by the Blowpipe, or by the Confirming Tests. The salt may be also presented upon the first occasion in its crystallised state, in order that the beginner may have the advantage of any information he can derive from the physical properties of the substance. In subsequent experiments, the quantity of the salts should be gradually reduced from 10 grains to 1 grain, and it should be presented in fine powder.

In some cases, and perhaps generally after the first two lessons, the compounds for examination may, in order to save time, be presented to the class in a state of solution, each pupil being furnished with a small bottle containing one or two drachms of the liquid that is to be tested. In this case, the teacher or his assistant prepares the solution previous to the assembling of the class, observing the precaution of making the solutions of the same strength that they would have been had they been prepared by the class individually, according to the instructions given in the text.

² *Method of inserting powders into deep narrow vessels.*—Take a long slip of highly-glazed writing-paper, as wide as the diameter of the mouth of the vessel into which the powder is to be inserted. Fold this longitudinally into a sort of gutter, and place the powder upon one end of it. Hold the vessel in a horizontal position, and insert the paper gutter into it, the end bearing the powder first. Then hold the vessel upright, upon which the powder falls from the paper to the bottom of the vessel. Withdraw the paper in such a manner as not to soil the deck of the vessel.

As the half of your salt is 5 grains, and the drachm of water is 60 grains, your solution will contain 1 in 12 of solid matter, which is a good proportion for most solutions.¹

Light your spirit lamp.² Push down the wick till the flame is not above an inch long. Hold the flask over the flame. Move it gently round in a small circle about an inch above the flame, so as to warm all parts of its bottom, and to mix the powder with the water by the gyration. You will soon see dew formed on the bottom of the flask. Wipe the dew away with a cloth. Again hold the flask over the flame. Again wipe off the dew.

Now place the furnace cylinder round the lamp—put the wire trellis upon the cylinder, and set the flask upon the trellis, exactly over the flame. Lift the flask about once a minute, and gently shake it round, to mix the powder with the water. As you have different salts to

¹ *To the Teacher.*—As you lessen the quantity of solid matter, you must prescribe the application of less water, else the solutions will become too dilute. The proportion of 1 to 12 may serve as a general rule, though sometimes more water is necessary.

² When this lesson is to be taught to a number of students, and gas is at command, spirit lamps may be economically dispensed with.

A long plank, about a foot broad (or two feet broad if the locality permits it), and two inches thick, is supported horizontally with the surface at 33 to 36 inches above the floor. A gas-pipe is fixed upon the centre of the upper side of this plank, and runs its whole length. At 18 inches distance from each other there are upright jets rising from this gas-pipe, the whole of which are under the control of the teacher, who stands at one end of the plank, where there is a stop-cock to regulate the issue of the gas—

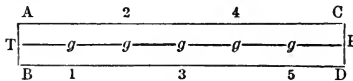

50.

The lines A B C D represent the upper surface of the plank. P is the gas-pipe running down its centre; g g g g g represent the jets of gas. T is the position of the teacher, who is able to see everything that is transacted the whole length of the board. The pupils who are to be exercised in experimenting, stand on both sides of the board, one opposite to every gas-light, as shown by the numbers 1, 2, 3, 4, 5.

If stoneware furnaces (fig. 21, p. 49) are to be used to support vessels over the gas jets, the long gas-pipe must be sunk into the surface of the plank; or it may be affixed to the under surface of the plank, and the jets be passed up through the plank. Each jet may also be provided with a separate stop-cock, where the cost can be afforded.

examine, your solutions will not all be produced in the same time, for some salts require more water than others, and more time to dissolve. What I have now to say will therefore concern only some of you. In three or four minutes the water will boil, and if present in sufficient quantity will dissolve the salt. But if the salt, after two or three minutes' boiling, does not dissolve, you must remove the flask from the lamp, let the boiling cease, insert a funnel into the flask, and add half a drachm more water. Then boil again.

The solution being thus effected is next to be filtered. Extinguish the flame; let the solution cool; and, in the meantime, prepare your filter.

Take a funnel-holder. Fix the horizontal branch of it at six inches above the foot. Put into the horizontal branch a glass funnel of $1\frac{1}{2}$ inch diameter. Take a circular filter of $2\frac{3}{4}$ inches diameter. Fold it

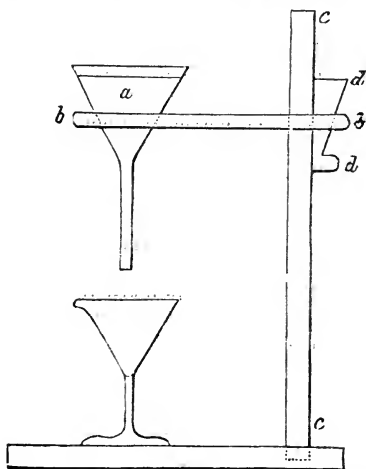

51.

into a quadrant. Open one of the folds so as to make a cone. Place it in the funnel, and sprinkle water over the paper by means of the washing bottle, till it is made wet enough to sit close to the bottom of the funnel. There must be a space of one-eighth of an inch between the top of the filter and the edge of the funnel; that is to say, the filter must be so much smaller than the funnel. Place a conical ounce test glass below the neck of the funnel, as I now show you. [See the cut.] Now pour the solution from the flask into the filter. Take care not to pour in so much at a time as to rise above the top of the filter. When the solution is all run through the filter into the test glass, you have it prepared for testing.

CLASSIFICATION OF TESTS.

I divide Tests into two Classes. The *First Class* comprises those which are most general in their reactions, and which, on being applied in proper order to the solutions prepared for testing, serve to *indicate* the metals and acids which *probably* compose the compounds subjected to analysis.

The *Second Class* comprises those more particular tests which on being applied to a compound *presumed*, from the action of tests of the first class, to be composed of certain constituents, serve either to *confirm* or to *disprove* the presumed composition of the substance submitted to analysis.

The first class are called *Indicating Tests*; the second class *Confirming Tests*.

I.—INDICATING TESTS.

I shall begin with the *Indicating Tests*, which are of two kinds, such, namely, as serve to point out the *metals* contained in the salts, and such as point out the *acids*.

A.—TESTING FOR METALS.

The application of tests always commences with the application of the Indicating Tests for Metals. These are five in number, namely:—

1. Carbonate of Soda.
2. Liquid Ammonia.
3. Caustic Potash.
4. Red Prussiate of Potash.
5. Sulphuretted Hydrogen Gas.

The first four of these tests you have ready in solution; the last you will prepare at the moment when it is required. I proceed to tell you how these tests are to be applied.

Experiment 1.—Pour six drops of the solution of the unknown salt into a conical test glass, fig. 52. Add to it three drops of *Carbonate of Soda*. Stir the mixture with a glass rod. If no precipitate appears, add three drops more of the carbonate of soda. Again stir the mixture.

You will get A PRECIPITATE OR NO PRECIPITATE. In either case, you are to record the result on the ASSAY NOTE, which I now hand to you, and upon which you will find directions for filling up the blanks.¹



52.

¹ *To Teachers.*—The ASSAY NOTE affords an easy and effectual check on the pupil's carefulness of manipulation and power of observation. A

If Carbonate of Soda produces *no precipitate*, the metal contained in the salt is one of these three:

- No. 1. Potassium.
2. Sodium, or
3. Ammonium.

In this case, you need apply none of the other Indicating Tests to your solution, for they can give no farther information. You will discriminate these three metals by means of the *Confirming Tests*, of which I shall speak after going through the set of indicating tests.

If, on the contrary, the carbonate of soda produces *a precipitate*, you write P on the Assay Note, and then proceed to apply the next test to your solution. The *colour* of the precipitate produced by carbonate of soda is of no importance in the present case, and need not be marked on the Assay Note.

Experiment 2.—Pour six drops of the unknown solution into another test glass, and add six drops of *Liquid Ammonia*. Stir the mixture.

If *no precipitate* is produced, the metal contained in the salt is

- No. 4. Barium.
5. Strontium, or
6. Calcium.

How to discriminate these three metals, I shall show you hereafter by means of *Confirming Tests*. You can get no farther information respecting any of them from the Indicating Tests.

If, however, you get *a precipitate* with *Liquid Ammonia*, you write P on your Assay Note, and proceed to the next reagent. In the present case, as in the last, the *colour* of the precipitate need not be marked on the Assay Note.

contrivance of this kind is quite essential when the number of pupils is so considerable that the teacher cannot readily see what every one of them is doing. Suppose that 20 students are engaged in simultaneous Testing. They are furnished with 20 different substances selected from the list given at page 67, and numbered 1 to 20. They are also provided with printed copies of the Assay Note, which at the conclusion of the Lesson are returned to you, duly filled up and subscribed by the 20 different analysts. As you know beforehand what ought to be written in every vacant space of each Assay Note, it is, of course, easy to check either an inaccurate experiment, or an erroneous deduction.

The superintendence of such a class, and the examination of the Assay Notes, can be intrusted to an assistant, provided he be furnished with a set of Assay Notes, filled up to correspond with the indications that would be afforded by all the substances enumerated at page 67.

ASSAY NOTE, No.

TESTS FOR THE METAL.

Carbonate of Soda	
Ammonia	
Potash	
Red Prussiate of Potash	
Sulphuretted Hydrogen	
METAL INDICATED	

TESTS FOR THE ACID.

Nitrate of Barytes	
Nitrate of Silver	
Nitrate of Lead	
Chloride of Calcium	
ACID INDICATED	

DIRECTIONS.—Against the word No. , write the number that is marked upon the envelope of the salt, or upon the bottled solution which is presented to you for analysis. Fill up the blank spaces opposite the names of the tests as follows:—If you get no precipitate, insert a cipher, 0. If you get a precipitate, write P, and add the colour of the precipitate, thus: *P white*, or *P brown*. If the precipitate dissolves in an excess of the test, add S after the colour, as *P white S*, *P brown S*. When the metal and the acid are indicated, write their names in the spaces provided for that purpose. Sign your name below.

_____, *Analyst*.

Date _____

Experiment 3.—Pour six drops of the unknown solution into an ounce-test glass. Then take a quantity (one or two fluid drachms) of *Caustic Potash* in a dropping tube such as I now show you. Hold the dropping tube in your left hand, and let the potash fall, *one drop at a time*, into the solution under analysis. Stir the mixture with a glass rod after each addition of potash.



53.

You will, in this case, *be sure to get a precipitate*, and you have two things to observe in respect to it—first, what *colour* it has, and secondly, whether, subsequent to its first production by means of a *small* quantity of potash, it can be dissolved, or made to disappear, by adding a *larger* quantity of potash.

The *colours* of the precipitates produced by caustic potash are *white, black, blue, green, yellow, and brown*. The white precipitates are distinguishable into two varieties; those which *dissolve* in an excess of potash, and those which *do not*.

Although it is impossible to apply potash at this stage of the analysis without causing precipitation, yet it is very possible to add, in carelessness, too much of the potash at once, and so to render the resulting precipitate invisible at the instant of its production. This is the reason why I tell you to add the potash *gradually*, that you may see the precipitate when first produced, and notice its colour before it is re-dissolved.

Fill up your Assay Notes according to what you observe, write P for precipitate, then the name of the colour, and add S when the precipitate is soluble in an excess of the potash.

I proceed to notice the different kinds of precipitates produced in this experiment, beginning with those of a *white* colour.

The *white precipitates* that are *insoluble* in an excess of potash indicate these five metals:—

No. 7. Manganese.

8. Iron, its protosalts.

9. Magnesium.

No. 10. Cadmium.

11. Bismuth.

I have now to tell you how to distinguish these five metals from one another.

Experiment 4.—Take six drops of the unknown solution in a test glass, and add two or three drops of a solution of *Red Prussiate of Potash*.

A *Brown* precipitate indicates Manganese.

A *Blue* precipitate indicates Protosalts of Iron.

No precipitate indicates Magnesium.

Any other precipitate is to be disregarded.

This leaves Cadmium and Bismuth undiscriminated.
Fill up your Assay Note, and proceed to the next test.

Experiment 5.—Take a few drops of the solution in a test glass, and add to it a drop or two of nitric acid. Dip into the mixture the end of a small glass tube, *b*, fig. 54, so as to take up a small film of the liquor.



54

Expose this to the action of *Sulphuretted Hydrogen Gas* as follows:—

Mix together one part of a Sulphide of Calcium, and three parts of Bisulphate of Potash, and insert the mixture into a small glass tube, in the manner shown by fig. 54 *a*. The figure shows the size of the tube and also the quantity of salts necessary to be used. Put the tube *b* into its place, warm the mixture at *a*, by holding the tube over a flame, or by putting it for a moment into your mouth. Then blow gently into the tubes at the end *c*.

Sulphuretted hydrogen gas will be disengaged from the mixed salts in the tube *a*, will act upon the solution at the end of *b*, and throw a coloured precipitate on the sides of that tube.

Under the given circumstances the colour must be either yellow or black.

Yellow indicates Cadmium.

Black indicates Bismuth.

Experiment 6.—The *White precipitates* which were produced by caustic potash, and *re-dissolved* by an excess of that test, indicate six metals, namely:—

No. 12. Zinc.

13. Tin, its protosalts.

14. Aluminum.

No. 15. Lead.

16. Tin, its persalts.

17. Antimony.

To distinguish betwixt these metals, take a fresh portion of the unknown solution, and add to it a few drops of the solution of *Red Prussiate of Potash*.

A *Yellow-red* precipitate indicates Zinc.

A *White* precipitate indicates Tin, protosalts.

Any other precipitate gives no useful indication.

Experiment 7.—Take four drops of the unknown solution, mix with it one drop of nitric acid, and expose a little of the mixture to an atmosphere of *Sulphuretted Hydrogen Gas*, in the manner related in Experiment 5. If a precipitate is produced, observe its colour.

No precipitate indicates Aluminum.

A *Black* precipitate indicates Lead.

A *Yellow* precipitate indicates Persalts of Tin.

An *Orange* precipitate indicates Antimony.

Experiment 8.—The *Black precipitate* produced by potash indicates
No. 18. Mercury, its protosalts.

Sometimes, however, potash produces a *slight* black precipitate with Gold. These black precipitates can be discriminated thus:—

To a fresh portion of the unknown solution, add a few drops of *Red Prussiate of Potash*.

A *Red-brown* precipitate indicates Mercury.

No precipitate indicates Gold.

Experiment 9.—The *Blue precipitates* produced by potash indicate
No. 19. Cobalt, and
20. Copper.

These two metals are discriminated¹ as follows:—

Pour both the solution and the precipitate into a small flask, or a test tube,² and boil the mixture over the spirit lamp till the precipitate changes colour.

If it turns *Red*, the metal is Cobalt.

If it turns *Black*, it is Copper.

Experiment 10.—The *Green precipitates* produced by potash indicate three metals, namely:—

No. 21. Nickel.

22. Chromium, and

23. Iron, mixtures of persalts with protosalts.

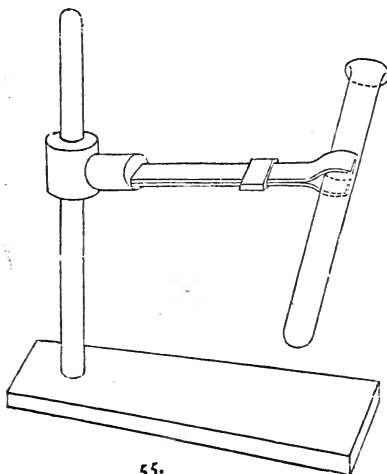

¹ Most solutions of cobalt have a red colour. Those of copper are blue or green.

² The annexed figure represents a tube-holder, an instrument by which a tube or small flask can be readily supported over a spirit-lamp flame, when a solution is to be boiled. The arm that holds the tube moves round in the socket that is affixed to the upright rod, so that the tube can be held in any desired position.

Another holder for tubes and flasks is shown on page 77.

You discriminate these three metals as follows:—

To a fresh portion of the unknown solution, add a few drops of a solution of *Red Prussiate of Potash*.

A *Yellow-green* precipitate indicates Nickel.

No precipitate indicates Chromium.

A *Light-blue* precipitate indicates Iron.

Experiment 11.—The *Yellow precipitates* produced by potash indicates two metals, namely:—

No. 24. Mercury, persalts.

25. Gold.

These are discriminated thus:—

To a fresh portion of the solution, add a few drops of a solution of *Red Prussiate of Potash*.

A *Yellow-red* precipitate indicates Mercury.

No precipitate indicates Gold.

No precipitate however also indicates the Perchloride of Mercury.

The discrimination of Perchloride of Mercury from Gold, I shall show you how to effect, when I come to speak of the confirming tests.

Experiment 12.—The *Brown precipitates* produced by potash indicate two metals.

No. 26. Iron, persalts.

27. Silver.

These you discriminate as follows:—

To a fresh portion of the solution, add a few drops of a solution of *Red Prussiate of Potash*.

No precipitate indicates Persalts of Iron.

A *Brown* precipitate indicates Silver.

Thus far we have considered the reactions of the Precipitants which indicate the *metals* or BASES of the salts we are examining. I proceed next to specify the reactions of the Precipitants which indicate their ACIDS.

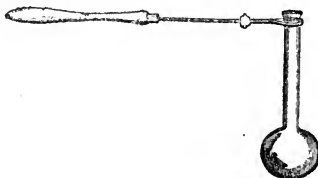

B.—TESTING FOR ACIDS.

The number of *Indicating Precipitants for Acids* is four. Their names are—

- | | | |
|------------------------|--|-------------------------|
| 1. Nitrate of Barytes. | | 3. Nitrate of Lead. |
| 2. Nitrate of Silver. | | 4. Chloride of Calcium. |

These you have already in solution, and you are to apply them in small quantities of 4 or 5 drops at a time, to similar small quantities of the unknown solution contained in separate test glasses, in the same manner as you applied the indicating precipitants for the metals.

The *results* of the testing you will carefully mark down upon the ASSAY NOTE as you proceed.

Experiment 13.—First of all, you take in a test glass a few drops of the unknown solution, and add to it a few drops of the solution of *Nitrate of Barytes*.

You will observe one of three results, to wit—

- No Precipitate.
- A White Precipitate.
- A Yellow Precipitate.

Experiment 14.—The salts which give *no precipitate* with Nitrate of Barytes, are of six kinds, namely:—

- | | | |
|------------------|--|-----------------|
| No. 1. Nitrates. | | No. 4. Iodides. |
| 2. Chlorates. | | 5. Arsenites. |
| 3. Chlorides. | | 6. Sulphides. |

To discriminate these from one another, you take a fresh portion of the solution, and test it with the solution of *Nitrate of Silver*.

No precipitate indicates Nitrates and Chlorates.

A White precipitate indicates Chlorides.

A Black precipitate indicates Sulphides.

Any other precipitate is to be disregarded.

The Indicating Tests can give you no farther information conducive to the discrimination of Nitrates from Chlorates. I shall hereafter show you how to effect this discrimination by means of *confirming tests*.

Experiment 15.—The Iodides and Arsenites are to be discriminated thus:—You test a fresh portion of the solution with a few drops of a solution of *Nitrate of Lead*, and notice the *colour* of the precipitate:—

Yellow indicates Iodides.

White indicates Arsenites.

Experiment 16.—The salts which give a *white precipitate* with Nitrate of Barytes, are of seven kinds, namely:—

- | | | |
|-------------------|--|-------------------|
| No. 7. Fluorides. | | No. 11. Oxalates. |
| 8. Phosphates. | | 12. Carbonates. |
| 9. Arseniates. | | 13. Sulphates. |
| 10. Borates. | | |

To proceed in the discrimination of these seven classes of salts from one another, you are to mix the solution which contains the white precipitate with a few drops, or not more than its own bulk, of *Nitric Acid*, and to stir up the mixture with a glass rod. This process separates the white precipitates into three classes, to wit:—

Those which *dissolve* in nitric acid *without effervescence*.

Those which *dissolve* in nitric acid *with effervescence*.

Those which *do not dissolve* in nitric acid.

Experiment 17.—The *white precipitates* which are produced by Nitrate of Barytes, and which *dissolve* in nitric acid *without effervescence*, and are accordingly denoted in your ASSAY NOTE—by P white S—indicate five salts, namely:—

Fluorides.

Phosphates.

Arseniates.

Borates.

Oxalates.

To distinguish these from one another you are to test a fresh portion of the solution with *Nitrate of Silver*.

No precipitate indicates Fluorides.

A *Yellow* precipitate indicates Phosphates.

A *Brown* precipitate indicates Arseniates.

Any other precipitate is to be disregarded.

Experiment 18.—Take in an ounce conical test glass two drops of the unknown solution, and add one drop of the solution of *Chloride of Calcium*. You will see a white precipitate, let whatever will be present. Now by means of the water bottle, page 31, slowly add *distilled water* to the mixture under continual stirring, till the precipitate dissolves, or till the test glass becomes nearly full.

If the precipitate is *soluble*, the salt is a Borate.

If it is *insoluble*, the salt is an Oxalate.

The *white precipitates* which are produced by Nitrate of Barytes, and which *dissolve* in nitric acid *with effervescence*, and are accordingly denoted in your ASSAY NOTE—by P white S eff.—indicate Carbonates.

The *white precipitates* which are produced by Nitrate of Barytes, and which *do not dissolve* in nitric acid, indicate Sulphates.

The *yellow precipitates* which are produced by Nitrate of Barytes indicate

No. 14. Chromates.

Such are the reactions of the indicating tests for acids.

I shall now present you with a synoptical view of these Indicating Tests, arranged in two separate TABLES, one of them showing the precipitants for *Metals*, the other the precipitants for *Acids*.

INDICATING PRECIPITANTS FOR METALS IN SALTS.

Solutions to be Neutral.				Solutions to be Acid.	METALS Indicated.	
Carbonate of Soda.	Ammonia.	Potash.	Red Prussiate of Potash.	Sulphuretted Hydrogen Gas.		
None None None					1 Potassium. 2 Sodium. 3 Ammonium.	
	None None None				4 Barium. 5 Strontium. 6 Calcium.	
		White White White White White	All 5 are insoluble in excess.	Brown Blue None	Yellow Black	7 Manganese. 8 Iron, protosalts. 9 Magnesium. 10 Cadmium. 11 Bismuth.
		White White White White White White	All 6 are soluble in excess.	Yellow-red White	None Black Yellow Orange	12 Zinc. 13 Tin, protosalts. 14 Aluminum. 15 Lead. 16 Tin, persalts. 17 Antimony.
		Black, See Gold, No. 25.		Red-brown		18 Mercury, its protosalts.
		Blue, If boiled, Red. Blue, If boiled, Black.				19 Cobalt. 20 Copper.
		Green Green Green		Yellow-green None Light Blue		21 Nickel. 22 Chromium. 23 Iron, persalts & protosalts mixed.
		Yellow Yellow. sometimes slight and black.		Yellow-red but none from the Perchloride. None		24 Mercury, its persalts. 25 Gold.
		Brown Brown		None Brown		26 Iron, persalts. 27 Silver.

INDICATING PRECIPITANTS FOR ACIDS IN SALTS.

Nitrate of Barytes.		Nitrate of Silver.	Nitrate of Lead.	Chloride of Calcium.	SALTS Indicated.
None		None	Yellow White		1 Nitrates.
None		None			2 Chlorates.
None		White			3 Chlorides.
None					4 Iodides.
None					5 Arsenites.
None		Black			6 Sulphides.
White	All 5 soluble in Nitric Acid, without Effervescence.	None		White, Sol. in water. White, Insol. in water.	7 Fluorides.
White		Yellow			8 Phosphates.
White		Brown			9 Arseniates.
White					10 Borates.
White					11 Oxalates.
White	Soluble in Acids with Effervesc.				12 Carbonates.
White	Insol. in Acids.				13 Sulphates.
Yellow					14 Chromates.

Before proceeding farther, I request you to compare these TABLES with your ASSAY NOTES, and to draw conclusions, from the results of your experiments, in regard to the nature of the substance which you have had to examine.

First, as to the METALS—suppose your ASSAY NOTE to read thus:—

Carbonate of Soda	P.
Ammonia	P.
Potash	P. Brown.
Red Prussiate of Potash	P. Brown.
Sulphuretted Hydrogen	

The interpretation must be as follows:—

Carbonate of Soda = P., shows that the metal is not one of the three first of those on the list of components given at page 65.

Ammonia = P., shows that the metal is not one of those from No. 4 to No. 6 in that list.

Potash = P. *brown*, shows that the metal is either Iron, No. 26, or Silver, No. 27. See Exp. 12, p. 77.

Red Prussiate of Potash = P. *brown*, shows finally that the metal is *Silver*.

Next, as to the ACIDS—let your ASSAY NOTE read thus:—

Nitrate of Barytes	P. white, sol.
Nitrate of Silver	o.
Nitrate of Lead	
Chloride of Calcium . . .	

Nitrate of Barytes = P. *white, sol.*,—shows the salt to be one of those from No. 7 to No. 11, in the list of salts given at page 65.

Nitrate of Silver = o, shows it to be a *Fluoride*.¹

¹ *To Teachers*.—At this point the teacher may either collect the ASSAY NOTES, and revise what has been done, or he may go on with the Confirming Tests, and leave the ASSAY NOTES with the pupils, until the testing is entirely finished.

The manner of teaching the methods of applying the Confirming Tests must be regulated by the number of persons to be taught, and the quantity of time and apparatus at command. All the students may go through the whole series of experiments, or each of them may be instructed to perform only those particular experiments which relate to the Metal and Acid indicated by his ASSAY NOTE.

But, indeed, a student can scarcely have a better set of elementary experiments, than that which consists in trying the action of Tests with all the salts at his command, so as to make himself acquainted with the *colours*, consistence, changeableness, &c., of the various precipitates which characterise different kinds of salts.

CONFIRMING TESTS.

WHEN you have applied the set of Indicating Tests, and imagine that you have detected both the base and the acid of your salt, it is proper to make use of the *Confirming* Tests, in order to convince yourself that there is no mistake.

These tests also are unavoidably necessary whenever you have to do with a nitrate, a chlorate, an alkali, or an alkaline earth—all of which compounds are left undiscriminated by the Indicating Tests which we have employed.

To guard against the possibility of error, the rule is good, to test the unknown substance, or its solution in water, with as many different precipitants, or by as many different experiments as you can conveniently employ—paying especial attention to the action of such tests as serve to distinguish the particular elements of your compound from such other elements as most nearly resemble them.

The set of Confirming Tests that I am about to give you, applies only to simple soluble salts, not to mixtures of salts, nor to impure salts, nor to salts that are insoluble in water, or that contain other metals or acids than those that were enumerated at the beginning of these Instructions (page 65).

Finally, these Confirming Tests presuppose the use of the Indicating Tests. They are consequently *Confirming* only when taken in conjunction with the reactions of the *Indicating* Tests. The reason of this is, that *all* the characteristics necessary to fix the identity of the different acids and bases are, for the sake of brevity, not brought into this section; but only so many as are necessary to accomplish the particular end in view, namely, that of discriminating the substances contained in the limiting Table given at the beginning of these Instructions. (See page 65).

Consequently, you are always to begin an analysis with the Indicating Tests, and conclude it with the Confirming Tests.

APPARATUS FOR CONFIRMING TESTS.

THE apparatus here cited is required for performing the Confirming Tests of this section. It is not necessary in teaching a CLASS, to supply each student with a complete set of this apparatus, because the same substances need not be given to all the students at the same time. Each set of apparatus for the Confirming Tests may suffice for four or six pupils.

Porcelain cup 1 inch diameter.
Round Retort Stand, with 1 ring
and 1 triangle.

Blowpipe.

Blowpipe Lamp on support.

2 Platinum Blowpipe wires.

2 Slips of Platinum foil for the
Blowpipe.

Platinum pointed tongs, fig. 60.

Thin Copper wire for Blowpipe
Experiments.

Box of Oxidating Pastiles.

Box of Reducing Pastiles.

3 Wires for holding Blowpipe
Pastiles.

Hammer.

Steel Anvil.

3 Tubes for sublimations, hard
glass, 2 inches by $\frac{1}{2}$ inch.

Box of Books of Test papers.

Support to show sublimates
before the blowpipe.

Blowpipe Fluxes in boxes:—

Borax.

Carbonate of Soda.

Microcosmic Salt.

Bottle for solution of Cobalt,
with pipette or long stopper.

Bottles for Reagents in solution,
2 oz. size, with stoppers, con-
taining:—

Yellow Chromate of Potash.

Red Chromate of Potash.

Yellow Prussiate of Potash.

Sulphate of Lime.

Antimoniate of Potash.

Molybdate of Ammonia.

Sulphuric Acid, concentrated.

Muriatic Acid.

Bottles with wide mouths, to
contain the following dry
Tests, 1 ounce size:—

Protosulphate of Iron, cryst.

Peroxide of Manganese.

Protochloride of Tin, cryst.

Sulphate of Copper, cryst.

Acetate of Lead, cryst.

Sulphate of Magnesia, cryst.

Chloride of Sodium, cryst.

The following Tests are only
required occasionally. It will
be sufficient if 1 bottle of each
is in the Laboratory.

Chloride of Platinum.

Chloride of Gold.

A.—CONFIRMING TESTS FOR METALS.

POTASSIUM, SODIUM, AMMONIUM.—See Experiments, 1, page 71.



56.

1. Take a porcelain cup of this size. Mix in it
a test spoonful of the dry salt, with a test spoonful
of carbonate of soda, and a few drops of water.
Support it over a spirit lamp and apply heat.
If the *odour of Ammonia* is produced, the salt
contains *Ammonium*.



57.

duced gas or spirit lamp flame, or else hold it before the blowpipe oxidating flame in this manner:—



58.

If a *strong yellow flame* is formed round the assay, *c, d*, the salt contains *Sodium*. If a *violet colour* or *no colour* is given to the flame, the salt contains *Potassium*.

You will observe that I suppose, throughout, that the salts under analysis are in a state of purity. The tests which I direct to be applied are not qualified to act upon *mixtures* of salts in the same manner as upon *simple* salts. Thus, for example, if a salt of *Potassium* is mixed with a salt of *Sodium*, the mixture submitted to the last experiment, gives only the character of *Sodium*, even if the mixture contains three hundred parts of Potassium to one part of Sodium. The person, therefore, who provides you with the *salts that are to be analysed*, and with the *tests that are to be applied to them*, must guard against any source of error of that description.

But since the presence of Sodium in salts of potassium is very common and very difficult to avoid, it is proper to apply the following *direct tests* for Potassium, in every analysis you make of an alkaline salt, whether it gives the yellow flame of soda or not.

3. Add to a concentrated solution of the salt, a drop of a solution of CHLORIDE of PLATINUM in spirit of wine.

A *yellow precipitate* indicates *Potassium*.

No precipitate indicates *Sodium*.

4. Add to a concentrated solution of the salt, which must not have any free acid, a few drops of a concentrated solution of ANTIMONIATE of POTASH. 59.

No precipitate indicates *Potassium*.

A *white crystalline precipitate* slowly formed indicates *Sodium*.



BARIUM, STRONTIUM, CALCIUM.— See Experiment 2, page 72, where the salts of Barytes, Strontian, and Lime, are distinguished from those of Potash, Soda, and Ammonia, by means of a solution of carbonate of soda. They may also be distinguished from the same salts by DILUTED SULPHURIC ACID, which gives a *white precipitate* with these Earths, but not with the Alcalies.

These three metals are most readily discriminated from one another by the conjoint action of solutions of YELLOW CHROMATE OF POTASH and BICHROMATE OF POTASH.

5. To a few drops of the concentrated solution of the unknown salt, add a few drops of a solution of BICHROMATE OF POTASH.

If you get a *precipitate*, the metal is *Barium*.

If you get no precipitate, test another portion of the concentrated solution of the unknown salt with a few drops of a solution of YELLOW CHROMATE OF POTASH.

If you get a *precipitate*, the metal is *Strontium*.

If you get *no precipitate*, the metal is *Calcium*.

ACTION of the two Chromates of Potash, with concentrated solutions of the Alcaline Earths.

Metals under Examination.	Bichromate of Potash.	Yellow Chromate of Potash.
Barium.	Precip.	Precip.
Strontium.	○	Precip.
Calcium.	○	○

These reactions do not, however, take place with distinctness in *dilute* solutions of these metals.

6. Take a bit of the solid salt in the platinum blowpipe tongs, moisten it with water, and dip it into the upper part of the blowpipe flame, in

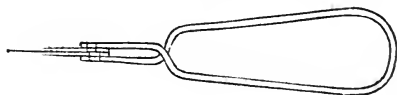

60.

this manner, fig. 61, where *c* represents the points of the tongs, and *b* the point of the blowpipe:—

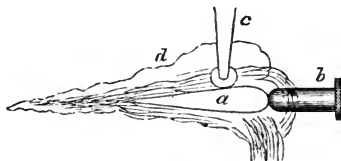

61.

If it gives a pale *green* colour to the upper part of the flame, as at *d*, it is *Barium*.

If it gives a *red* colour to the flame, it is *Strontium* or *Calcium*.

The last two metals are distinguished as follows :—

7. To a solution of the salt, add a solution of **SULPHATE OF LIME**, prepared by boiling precipitated Sulphate of Lime in water.

If it gives a precipitate, the metal is *Strontium*.

If not, the metal is *Calcium*.

MANGANESE.—See Experiment 4, page 74.

8. Take a platinum blowpipe foil, mix on it a bit of the dry salt with a test spoonful of dry **CARBONATE OF SODA**, and fuse the mixture before the blowpipe. The melted mass acquires a *green* colour.

9. Make a bead of Borax on the platinum wire before the blowpipe, and melt in it a little of the dry salt. Use the outer blowpipe flame. See Experiment 31, page 90. The bead acquires an *amethyst* colour.

IRON.—See Experiments 4, 10, and 12, pages 74, 76, and 77.

10. Add a few drops of a solution of **YELLOW PRUSSIAN OF POTASH** to a solution that contains a *salt of iron*.

A *white* precipitate indicates a *Protosalt* of Iron.

A *dark-blue* precipitate indicates a *Persalt* of Iron.

A *pale-blue* precipitate indicates a mixture of the two species.

11. Expose a solution of a *Protosalt of Iron* to an atmosphere of **SULPHURETTED HYDROGEN GAS**, See Experiment 5, page 75. It gives *no precipitate*.

12. Add to the solution of the *Protosalt of Iron* as much **AMMONIA** as gives it a strong smell of Ammonia, and again expose it to the atmosphere of **SULPHURETTED HYDROGEN GAS**. A *black* precipitate is produced.

13. Treat in the same manner a solution of a *Persalt* of Iron. Without *Ammonia*, it gives a *white* precipitate; and *with* Ammonia, a *black* precipitate.

MAGNESIUM.—See Experiment 4, page 74.

ALUMINUM.—See Experiment 7, page 75.

ZINC.—See Experiment 6, page 75.

14. Mix a test spoonful of the salt with a little water, spread it on charcoal in a flat cake of this size, and ignite it before the blowpipe. Then moisten the ignited salt with a drop of a strong solution of nitrate of cobalt, and again heat it before the blowpipe to redness. ○
When it is cold, examine the change of colour produced :— 62.

A salt which acquires a *flesh-red* colour from this treatment contains *Magnesium*.

If its colour is *blue*, the salt contains *Aluminium*.

If it is *green*, the salt contains *Zinc*.

These colours are best examined by daylight.

CADMIUM.—See Experiment 5, page 75.

15. Mix half a test spoonful of the salt with as much dry CARBONATE OF SODA, and heat it on charcoal in the inner (reducing) flame of the blowpipe.

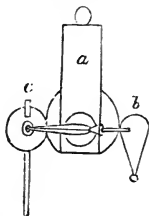

63.

A *brown powder* will appear round the assay, upon the charcoal.

[The figure shows the method of exposing a substance on charcoal to the flame of the blowpipe; *a* is the blowpipe lamp, *b* the blowpipe, *c* the assay upon a round disc of charcoal held by a bent slip of tin-plate.]

BISMUTH.—See Experiment 5, page 75.

16. Treat the salt in the same way as the salt of Cadmium, in Experiment 15.

A *yellow powder* is perceived on the charcoal, with a metallic bead in the centre of it.

Wrap the bead of metal in paper and give it a stroke with a hammer. You will find it to be *brittle*. See Experiment 19, below.

ZINC.—See Experiment 6, page 75.

17. I spoke of this metal in connection with Magnesium, Exper. 14. With SULPHURETTED HYDROGEN, zinc gives a *White precipitate*.

TIN.—See Experiments 6 and 7, page 75.

18. Mix a solution of a *Protosalt of Tin* with a few drops of a solution of CHLORIDE OF GOLD. A *purple precipitate* appears.

19. Mix a small bit, not larger than a pin's head, of a dry salt of tin, either containing the *protoxide* or the *peroxide*, with a test spoonful of dry CARBONATE OF SODA, and half that quantity of BORAX. Place the mixture on charcoal, and heat it strongly and for some time in the inner blowpipe flame, till the metal of the salt is reduced. See Experiment 31, page 90.

You will obtain a bright white metallic bead, which *flattens* when struck with the hammer. The malleability of beads of this metal, distinguishes them from beads of *Bismuth* produced in similar experiments. (Exp. 16.) Their brilliancy distinguishes them from *Lead*.

ALUMINUM.—See Experiment 7, page 75.

20. I spoke of this metal in connection with Magnesium. See Experiment 14.

Add to the solution of the salt of alumina a small quantity of solution of CAUSTIC POTASH, or CARBONATE OF POTASH, and then SULPHURIC ACID in slight excess, so that the mixture will redden blue litmus paper. After some delay, *crystals of alum* will be produced in the mixture.

LEAD.—See Experiment 7, page 75.

21. Mix half a test spoonful of the dry salt with a test spoonful of

dry CARBONATE OF SODA, place the mixture on charcoal and heat it in the inner blowpipe flame, till the metal is reduced.

You will obtain beads of METALLIC LEAD, and the charcoal acquires a coating of *yellow powder*.

These beads differ from those of *Tin* by being convertible into a volatile oxide, and from those of *Bismuth* by being *malleable* and not brittle.

22. Mix a drop of a solution of lead with a test glass full of water, and add a few drops of SULPHURIC ACID.

You will obtain a *white precipitate*.

ANTIMONY.—See Experiment 7, page 75.

23. Mix half a test spoonful of the dry salt with a test spoonful of dry CARBONATE OF SODA, and ignite the mixture on charcoal in the inner blowpipe flame till the metal is reduced.

You will obtain *globules of metal* from which a thick white smoke will rise.

If a melted bead of antimony is thrown on the ground, it divides into several globules which produce a thick white smoke (oxide of antimony).

MERCURY.—See Experiment 8, page 76.

24. Mix half a test spoonful of the dry salt with a test spoonful of dry CARBONATE OF SODA. Put the mixture into a little glass tube, and heat it over the spirit lamp.

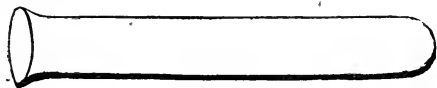

64.

You will soon see *metallic mercury* condensed upon the upper part of the tube.

25. Mix a solution of a salt of Mercury with a few drops of AMMONIA.

A *black* precipitate indicates a *Protosalt* of Mercury.

A *white* precipitate indicates a *Persalt* of Mercury.

COBALT.—See Experiment 9, page 76.

26. Make a glass bead with borax on a platinum wire before the blowpipe. To this add a bit of the salt of cobalt, much smaller than a pin's head, and melt it into the bead.

The glass acquires a dark-blue colour, both in the outer and inner flame.

27. Mix a few drops of a solution of cobalt with a solution of RED PRUSSIAN OF POTASH.

You get a *brownish-red* precipitate.

COPPER.—See Experiment 9, page 76.

28. Mix a few drops of a solution of copper with a solution of RED PRUSSIAN OF POTASH.

The precipitate is *yellowish-green*.

29. Mix the solution of copper with a *very small* quantity of AMMONIA. You get a *greenish* precipitate, which dissolves in a larger quantity of ammonia, and produces a splendid blue solution.

30. Mix the solution of Copper with a solution of YELLOW PRUSSIAN OF POTASH.

The precipitate is *reddish-brown*.

31. Melt a small quantity of the dry salt in a borax bead before the blowpipe.

In the *outer* flame, it gives a *transparent-green* glass.¹

In the *inner* flame, it gives an *opaque-brown* glass.²

NICKEL.—See Experiment 10, page 76.

32. Mix the solution of Nickel with a *very small* quantity of AMMONIA.

You get a *greenish* precipitate, which dissolves in a larger quantity of Ammonia, and gives a *violet* coloured solution.

33. Mix the solution of Nickel with a solution of YELLOW PRUSSIAN OF POTASH.

The precipitate is *pale green*.

¹ The following figure shows the method of exposing a substance to the *outer* or *oxidating* flame of the blowpipe.

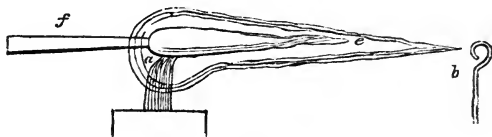

65.

² The following figure exhibits a bead exposed to the *inner* or *reducing* blowpipe flame.

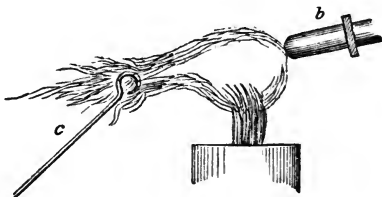

66.

CHROMIUM.—See Experiment 10, page 76.

34. Melt a little of the dry salt of oxide of Chromium in a borax bead before the blowpipe.

It gives a *transparent-green glass*, both in the inner flame and outer flame.

35. Mix the solution of oxide of Chromium with a few drops of AMMONIA.

The colour of the precipitate is *grey*, by candle-light *violet*.

36. Mix the solution of oxide of Chromium with YELLOW PRUSSIAE OF POTASH.

There is no precipitate.

GOLD.—See Experiments 8 and 11, pages 76, 77.

37. Mix the solution of Gold with a solution of PROTOSULPHATE OF IRON.

A *dark-brown* precipitate of metallic gold is produced.

38. Mix the solution of Gold with a solution of YELLOW PRUSSIAE OF POTASH.

The solution acquires an *emerald-green colour*.

39. Mix the solution of Gold with a solution of PROTOCHLORIDE OF TIN.

A *purple* precipitate is produced.

SILVER.—See Experiment 12, page 77.

40. Mix a diluted solution of Silver, with a few drops of MURIATIC ACID, or of a solution of ANY CHLORIDE.

You will get a *white precipitate*.

If you add AMMONIA to the mixture the precipitate dissolves.

If you add NITRIC ACID to the mixture the precipitate remains undissolved.

41. Mix the dry salt of Silver with dry CARBONATE OF SODA, and ignite the mixture on charcoal before the blowpipe.

Bright metallic silver appears on the charcoal.

B.—CONFIRMING TESTS FOR ACIDS.

NITRATES.—See Experiment 14, page 78.

42. Take a porcelain cup, and a test spoonful of the Nitrate. Prepare a solution. Add a few drops of sulphuric acid. Place a crystal of green sulphate of iron in the middle of the solution. Support the cup over the spirit lamp, and apply heat. You will see a dark-brown colour produced near the crystals. Shake the cup. The brown colour spreads through the whole liquor.



43. Mix the dry Nitrate with dry Bisulphate of Potash, a test spoonful of each. Put the mixture into a large test tube, and heat it over the spirit lamp.

You will observe the tube to be filled with *dark-yellow gas*. This experiment serves to distinguish Nitrates from Chlorates.

44. Put the dry Nitrate into a large test tube. Add Muriatic Acid. Apply heat.

White vapours of Nitric Acid are expelled. They redden litmus paper.

CHLORATES.—See Experiment 14, page 78.

45. Put a very small quantity of the dry Chlorate into a large test tube. Add Muriatic Acid. Apply heat.

A *yellowish-green gas* is expelled, having a very pungent odour.

46. Take a small test tube. Put into it a test spoonful of the dry Chlorate. Apply heat. The salt melts and oxygen gas soon after issues from the tube. In flame a bit of wood. Blow out the light, and hold the glimmering match to the mouth of the tube. The oxygen gas re-illumes the match. This experiment does not distinguish Chlorates from Nitrates.

47. Take a bit of thin copper wire. Make a coil at the end of it, and melt into the coil a crystal of microcosmic salt. Hold the coil over a small flame till the salt ceases to effervesce, and the wire becomes red hot. Now press the hot bead upon a bit of the dry

Chlorate, not larger than a pin's head. Reduce the flame of your lamp as low as you can without extinguishing it—so low as to leave only a small blue flame. Hold the coil with the Chlorate upon it, so that it shall just touch the top of the reduced flame. Thereupon a *bright blue flame* surrounds the subject of experiment. This experiment completely distinguishes Chlorates from Nitrates.

All substances that contain CHLORINE give this *blue flame*, and all substances that contain IODINE, treated in the same way, give a splendid *green flame*.

CHLORIDES.—See Experiment 14, page 78.

I have spoken already, Experiment 40, of the detection of Silver by solutions of CHLORIDES. The operation of detecting Chlorides by solutions of SILVER is the same.

The method of detecting Chlorine by means of microcosmic salt and a copper wire, explained already, in treating of CHLORATES, Experiment 47, is equally applicable to CHLORIDES.

48. Mix the dry salt with concentrated Sulphuric Acid in a large test tube, and apply heat.

White vapours of Muriatic Acid are formed. Hold a glass rod

moistened with Ammonia at the mouth of the tube. A thick *white smoke* is produced.

49. Take a test tube. Mix in it a test spoonful of the dry salt with a few drops of concentrated Sulphuric Acid and a test spoonful of *Peroxide of Manganese*. Apply heat.

In this case *Chlorine gas* is disengaged. It has a green colour and suffocating odour.

IODIDES.—See Experiment 15, page 78.

50. Take a large test tube. Put into it a test spoonful of the dry salt mixed with an equal quantity of dry BISULPHATE OF POTASH. Apply Heat.

You will see *Violet Vapours* of Iodine in the tube.

The method of detecting IODINE by means of a copper wire, I have explained in speaking of the CHLORATES, Exp. 47.

51. Mix a few drops of the Solution of the Iodide with a few drops of NITRIC ACID, and add a small quantity of STARCH PASTE prepared with hot water, or else use a test paper impregnated with starch.

A *blue colour* is produced. The paper turns *blue*.

52. Pour the Solution of the Iodide in which the Indicating Test, NITRATE OF LEAD, Experiment 15, page 78, has formed a yellow precipitate, into a test tube, and boil it with the precipitate.

When the solution cools, brilliant flat golden-yellow crystals appear in it.

ARSENITES.—See Experiment 15, page 78.

53. Mix the solution of the Arsenite with a solution of SULPHATE OF COPPER.

A *Green Precipitate* is produced.

54. Mix the solution of the Arsenite with a solution of NITRATE OF SILVER, and a very small quantity of AMMONIA.

A *yellow precipitate* is produced.

55. Mix the solution of the Arsenite with a drop or two of Muriatic acid, and expose the mixture to an atmosphere of SULPHURETTED HYDROGEN GAS (See Experiment 5, page 75).

A *yellow precipitate* is produced.

56. Mix half a test spoonful of the dry salt with a test spoonful of dry CARBONATE OF SODA. Heat the mixture on Charcoal in the inner blowpipe flame. After a short ignition, hold the charcoal under your nose. You will perceive *the odour of garlic*, by which metallic arsenic is specially characterised. Be cautious in smelling the vapour of arsenic, as it is poisonous.

SULPHIDES.—See Experiment 14, page 78.

57. Take a test tube. Mix in it a test spoonful of the dry Sulphide with a little *Muriatic Acid*. Apply Heat.

Effervescence is produced, and the odour of *Sulphuretted Hydrogen Gas* is perceived. A bit of white paper moistened with a solution of Lead, and held at the mouth of the tube, turns *black*.

58. Heat a test spoonful of the dry Sulphide on charcoal before the blowpipe.

The odour of SULPHUROUS ACID GAS will be perceived.

FLUORIDES.—See Experiment 17, page 79.

59. Take a small test tube. Mix in it the Fluoride with dry BISULPHATE OF POTASH, a test spoonful of each. Put a slip of moistened Brazil wood test paper into the upper end of the tube. Apply Heat.

Hydrofluoric acid will be disengaged by the mixture, and will *corrode* the inside of the tube, and change the red colour of the Brazil test paper to *yellow*.

Wash and dry the tube to render the corrosion visible.

PHOSPHATES.—See Experiment 17, page 79.

60. Precipitate a few drops of the solution of the Phosphate with a solution of ACETATE OF LEAD. Collect the white precipitate upon a filter. Wash it. Dry it. Place it upon Charcoal and melt it in the outer flame of the blowpipe.

When the bead cools, it will be of a dark colour, opaque, and *crystallised into numerous facets*. By this character the Phosphates are distinguished from the Arseniates. See Experiment 63, page 95.

61. Mix a solution of the Phosphate with a solution of SULPHATE OF MAGNESIA, and add AMMONIA.

You will get a *white precipitate*.

62. Add to a solution of MOLYBDATE OF AMMONIA as much Nitric Acid as will redissolve the precipitate which it first produces. Then add an extremely small quantity of the solution of the Phosphate, and *boil the mixture*. The operation should be performed in a test tube.

You will obtain a *yellow precipitate*.

This is the most delicate and certain test for phosphoric acid. No other acid, not even Arsenic acid, which resembles phosphoric acid in so many other particulars, can produce this yellow precipitate in an acidified solution of Molybdate of Ammonia.

ARSENIATES.—See Experiment 17, page 79.

In speaking of the *Arsenites*, I have shown in what manner the *Arsenic* which they contain can be detected before the blowpipe (see Experiment 56, page 93). The same experiment answers also with the Arseniates.

The differences between the Arsenites and Arseniates is best shown by the Indicating Tests, NITRATE OF BARYTES, Experiment 14, page 78, and NITRATE OF SILVER, Experiment 17, page 79.

The difference between the Arseniates and Phosphates, which agree in many respects, is shown by the Indicating Test, NITRATE OF SILVER, Experiment 17, page 79, and by the experiment just described, with MOLYBDATE OF AMMONIA, No. 61.

It is also exhibited in an experiment which I shall now give you.

63. Precipitate a solution of the Arseniate by a solution of ACETATE OF LEAD. Collect the white precipitate on a filter. Wash it. Dry it. Ignite it on charcoal, in the outer flame of the blowpipe.

When the bead cools, it will not be found crystallised into facets, as is the case with the precipitated *phosphate* of Lead.

64. Again, heat the fused bead of *Arseniate* of Lead in the *inner* flame of the blowpipe.

You will perceive a thick smoke which you will find to possess the odour of Arsenic, and you will get beads of metallic lead. These effects are not produced by *phosphate* of lead.

BORATES.—See Experiment 18, page 79.

65. Take a large test tube. Mix in it a concentrated solution of the Borate, with some SULPHURIC ACID. Boil the mixture, and let it cool.

You will perceive flat shining crystals of Boracic Acid.

66. Pour off the liquid. Wash the crystals from sulphuric acid with a little cold water. Repeat the washing several times. Then boil the crystals with water in a test tube. Test the solution with Litmus paper and Turmeric paper.

The blue litmus is turned *Red*.

The yellow turmeric is turned *Brown*.

67. Take a porcelain cup. Mix the solution of the Boracic Acid, or else a test spoonful of the solid Borate moistened with sulphuric acid, with a few drops of alcohol. Inflammate the mixture.

You will see a *green flame*.

OXALATES.—See Experiment 18, page 79.

68. Take a large test tube. Put into it three test spoonfuls of the dry oxalate. Add a few drops of concentrated sulphuric acid. Apply a moderate heat.

Effervescence takes place. The gas that escapes is a mixture of carbonic acid and carbonic oxide.

Apply a light to the mouth of the tube. The carbonic oxide *burns with a blue flame*.

69. Mix the solution of the oxalate with a solution of SULPHATE OF LIME.

You will get a *white precipitate*.

CARBONATES.—See page 79.

70. Mix the dry Carbonate with a little water. Add a few drops of MURIATIC ACID.

Effervescence takes place. The gas that escapes is *without odour*.

SULPHATES.—See page 79.

71. Mix a test spoonful of the dry sulphate with as much dry carbonate of soda. Place it on charcoal, and heat it in the inner flame of the blowpipe. Lay the fused mass on a piece of bright silver, and add to it a drop of water. After a minute's repose, wash the mixture from the silver.

You will perceive a *black mark* on the silver.

This experiment distinguishes the SULPHATES from all other salts in our list except the SULPHIDES, from which they are distinguished by Experiment 57.

CHROMATES.—See page 79.

72. Take a large test tube. Mix in it a test spoonful of the dry Chromate, with the same quantity of CHLORIDE OF SODIUM, and a few drops of concentrated SULPHURIC ACID. Apply heat.

Effervescence takes place, and the tube becomes filled with a *splendid red gas*.

73. Take a large test tube.¹ Mix in it a test spoonful of the Chromate, with a few drops of muriatic acid, and a few drops of alcohol, and boil the mixture over the spirit lamp.

The boiling liquor gives off muriatic ether, and the colour of it becomes *green*.

74. Before the *blowpipe*, the salts of chromic acid give the same results as the salts of oxide of chromium. See Experiment 34, page 90.

¹ Test tubes have been frequently directed to be used in the preceding experiments.



69.

As in such experiments scrupulous cleanliness is required, I may add a few words respecting the mode of cleaning such tubes. After each experiment they should be filled with water, before the products of the experiment have dried upon the surface. If the matters adhere, they may be removed by the use of a brush resembling fig. 69. Waste solutions of acids, alcalies, and alcohol, are used in cleaning glass vessels.

To Teachers.—Where Chemistry is taught only in Lectures, because no conveniences exist for teaching Practical Chemistry, it is an excellent practice for the teacher to give his pupils specimens of salts, such as are enumerated at page 67, to be analysed at their own houses. This method is practised at the German Universities with much success. The students apply themselves to these minute analyses with great zeal, and rapidly acquire considerable analytical skill.

ON THE PERFORMANCE OF ANALYTICAL EXPERIMENTS BY MEANS OF EQUIVALENT TEST LIQUORS.

CENTIGRADE TESTING.

CHEMICAL substances act upon one another in quantities that are represented by their atomic weights. I have explained that subject fully in another section. The weights given in the table at page 19 state a quantity of each substance, which, when weighed in English grains, constitutes what I call a *Test atom*. Thus, 56 grains is the test atom of hydrate of potash, KHO; and 49 grains is the test atom of hydrated sulphuric acid, HSO². See page 18.

When a test atom of any substance is dissolved in water, and the solution is farther diluted with water till it occupies the bulk of a decigallon, at the temperature of 62° F., I call that a *solution of one degree of strength*, and I mark it 1°. Hence, a solution of *hydrate of potash of 1°* contains 56 grains of that salt in a decigallon of solution. *Sulphuric acid of 1°* contains 49 grains of the hydrated acid in a decigallon of the diluted acid. If *five test atoms* of the dry test are contained in the same bulk of solution, I call its strength 5° (*five degrees*), &c. It is evident from this, that equal measures of solutions of the same degree are equivalent in chemical power to each other, and that any quantity by weight of a test can be taken by measuring off a corresponding quantity of its solution of a known degree of strength.

APPARATUS FOR CENTIGRADE TESTING.

For operating in this way it is necessary to be provided with graduated glass instruments, such as I shall now describe.

The bottle fig. 71 in the margin contains, when filled up to a mark on the neck, 1 decigallon, or 1000 septems, or $\frac{1}{16}$ gallon, of any liquor.

To prevent any misconception as to the relations and capacities of the DECIMAL MEASURES employed in Centigrade Testing, I must call the reader's attention to the Tables of Imperial Liquid Measures presented in page 98. The upper table shows the measures that are established by Act of Parliament. The lower table explains the decimal system, which I recommend for chemical use.

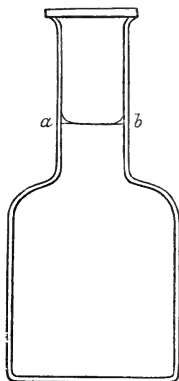

71.

IMPERIAL LIQUID MEASURE.

CORRESPONDENCE OF THE WEIGHT AND MEASURE OF WATER.
 Temperature 62° F. Barom., 30 inches. Weight, Avoirdupois.

Gallon.	Quarts.	Pints.	Pounds.	Fluid Ounces.	Cubic Inches.	Fluid Drachms.	Grains.
1	4	8	10	160	277·274	1280	70000
	1	2	2·5	40	69·3185	320	17500
		1	1·25	20	34·6593	160	8750
$\frac{1}{10}$			1	16	27·7274	128	7000
$\frac{1}{70}$			$\frac{1}{7}$	2·286	3·96106	18·286	1000
$\frac{1}{100}$			$\frac{1}{10}$	1·6	2·77274	12·8	700
				1	1·73296	8	437·5
				·5770	1·0	4·6164	252·458
				·2286	·396106	1·8286	100
				·2083	·361033	1·6667	91·1458
$\frac{1}{1000}$			$\frac{1}{100}$	·16	·277274	1·28	70
				·125	·216620	1·0	54·6875
$\frac{1}{10000}$			$\frac{1}{1000}$	·016	·027727	·128	7
				·0023	·003961	·01829	1

The figures that have a dot over them are inexact.

IMPERIAL LIQUID MEASURE.

DIVIDED DECIMALLY.

Gallon.	Deci-Gallons.	Centi-Gallons.	Milli-Gallons.	Septems.	Avoirdupois Weight of Water at 62° F.	
					Grains.	Pounds.
1·	10·	100·	1000·	10000·	70000·	10·
·1	1·	10·	100·	1000·	7000·	1·
·01	·1	1·	10·	100·	700·	·1
·001	·01	·1	1·	10·	70·	·01
·0001	·001	·01	·1	1·	7·	·001

1 Quart = 2500 Septems. 1 Fluid Ounce = 62·5 Septems.
 1 Pint = 1250 Septems. 1 Cubic Inch = 36·06543 Septems.
 1 Centimetre Cube = 2·2 Septems. 1 Litre = 2·2 Decigallons.

The unit of this system of decimal measures is called a SEPTEM, because it contains 7 grains of pure water at the Parliamentary Standard.

100 Septems = $\frac{1}{10}$ lb. of water = $\frac{1}{1000}$ gallon.

1000 Septems = 1 lb. of water = $\frac{1}{100}$ gallon.

10,000 Septems = 10 lbs. of water = 1 gallon.

I give the name of DECIGALLON to the measure that contains 1 lb. of water, or the tenth part of the Imperial Gallon.

The table itself explains all other relations.

Fig. 72 represents a CENTIGRADE TEST TUBE, more commonly called an *Alcalimeter*. It is a narrow glass jar, with a grooved stopper, by using which the contents can be poured out very slowly. It is graduated into a hundred equal parts, each part containing a septem, and the whole 100 parts being equal to a centigallon, or the tenth part of a decigallon.

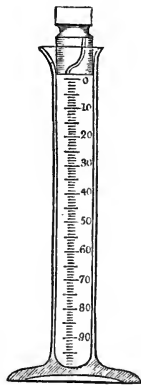

72.

This particular form of the centigrade test tube is not essential, and it may therefore be proper to add an account of one or two other varieties of that instrument.

Fig. 73 *d* in the margin represents the Pouret or Burette invented by M. Gay Lussac. This is a very convenient and delicate instrument, but rather fragile.

It is, in consequence, less suited for common workmen, than the instrument represented by fig. 72, but it gives more precise results.

I have added two or three little conveniences to the pouret, which I shall describe. *b*, Fig. 74, is a cylindrical block of wood, the ends of which are cut at right angles with the sides.

In the front is a vertical groove. When the block is placed on a horizontal table, *a*, Fig. 73, and the tube is pressed against the groove, the tube is placed at once in a perfectly vertical position, necessary for the accurate observation of the height of the liquor contained within it.

c is a japanned tin plate, with a horizontal opening covered with white tissue paper. When the surface of the liquor in the pouret is placed against this narrow screen, the height of the liquor can be observed with exactness.

The lower part of the curve formed by the surface of the liquor is taken in all cases as the true level, and this is well defined, when looked at before the screen.

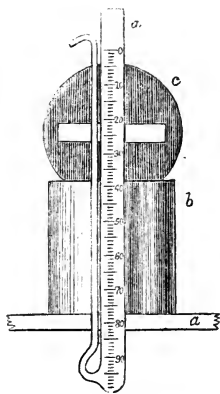

73.

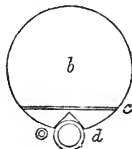

74.

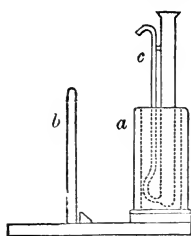

75.

As the pourer is round at the bottom, it requires a separate foot to support it when filled with test liquor. This foot is shown in the margin. *c* is the pourer; *a* is a wooden pillar perforated by an oval hole that supports the pourer in an upright position. When the pourer has been washed, it can be inverted on the peg *b* to drain.

The centigrade tube represented by fig. 76 in the margin is equally simple and delicate. It was suggested by Mr. Binks. The tube can be fixed in a vertical position by the levelling block described above, and be supported by a mahogany foot of the candlestick form.

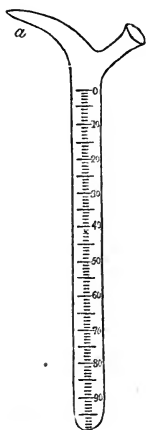

76.

In using these alcalimeters, they should be held close to the upper end, and when the one with a stopper, fig. 72, is used, the forefinger should be firmly pressed upon the stopper, to keep it in its place. The spout of the alcalimeter must be always greased with a mixture of tallow and wax, to hinder the test liquor from running down the outside of the tube. The tallow is best applied by means of a wooden syringe called a tallow-holder, represented by fig. 77. The mixture of wax and tallow is melted in a porcelain cup and poured warm into the holder, from which it is forced out by the piston as required. In applying the tallow to the beak of the pipette, it should be rubbed on pretty freely, and a small round hole should be pierced through the tallow with a needle. This hole regulates to some extent the force of the stream given by the alcalimeter.



77.

Another form of alcalimeter has recently been invented by Dr. Mohr of Coblenz, which, for most purposes, especially for the analysis of acids and alcalies, in chemical

manufactories, is more useful than any of the above forms. It consists of a straight graduated glass tube, *a*, fig. 78, open at both ends, and fixed vertically to a support with two branches, *b, b, b*. A small glass jet, *c*, is appended to the lower end, by means of a caoutchouc connector, across which a peculiar wire stopcock, *d*, acts. When the stopcock is untouched, the test liquor remains quiet in the tube. When the stopcock is pressed, the liquor descends in a stream, or in single drops, as may be required. When the action is completed, the quantity of test liquor expended is indicated by the centigrade scale, engraved on the tube between *e* and *f*; zero being made at *e*, and 100° at *f*.

Whatever the *form* of the alcalimeter, it must be divided into at

least 100 measures, each containing a septem. In general it is better to have a few more than 100 measures, but a smaller number is not convenient, except for special purposes.

I proceed to notice some other useful instruments.

TEST-MIXER.—Fig. 79 is a *Test-Mixer*, a tall narrow bottle, graduated into a hundred equal parts, and figured from below upwards. The capacity of it may be one, two, or five decigallons, according to the quantity of test liquor that may be required. For small operations, a test-mixer of one decigallon is sufficient. It must be well stoppered, and have a broad foot that it may stand steadily.

Very frequently a test-mixer of the form of fig. 80 is useful. It may contain 100, 200, or 250 septems, and must be graduated into 100 divisions, numbered from below upwards, so as to have zero (0°) of the scale at the bottom. In the figure, the graduation is numbered the wrong way. This instrument serves to prepare test solutions of graduated strength for analytical operations of every description.

PIPETTES TO DELIVER FIXED QUANTITIES OF TEST LIQUORS.—Fig. 81 is a pipette so graduated, that when filled up to the mark *a*, *b*, it delivers

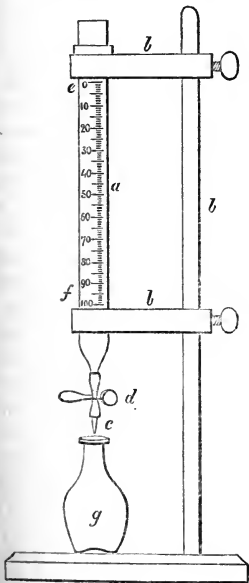

78.

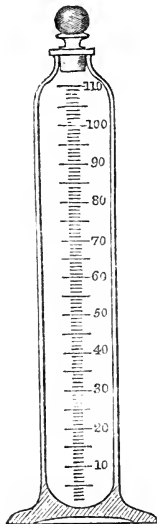

79.

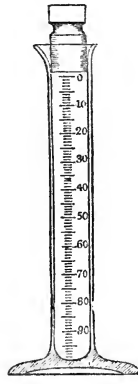

80.



81.

exactly 100 septems of solution, without reference to what adheres to the inner surface of the glass. The last drop must be blown from the point

by applying the mouth to the upper end of the tube, while the lower end touches the inside of the glass receiving-vessel.



82.

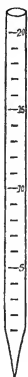

83.

Fig. 82 is a similar pipette, for the delivery of 10 septems of solution. It is useful to have other pipettes to deliver such quantities as 25 or 50 septems, or any arbitrary quantity necessary for a given purpose.

Fig. 83 represents a long narrow pipette, graduated to single septems, of which it may conveniently contain about 20 or 30. The use of this is, to deliver any small quantity of test liquor, such as 1, 2, 5, 10, or any uneven number of septems. See also fig. 87.

To use a Pipette.—Hold it by the thumb and middle finger of your right hand; slightly wet the ball of the forefinger; dip the lower end of the pipette into the liquor that is to be measured; apply your mouth to the upper end of the pipette, suck up the liquor, and watch its rise till it is a little above the mark on the neck of the tube; then cease to suck; rapidly slip your forefinger on the upper orifice of the tube, and press it firmly. In going through this process, *remember* that the test liquors are *poisonous*, and must not be sucked into your mouth. To prevent this accident, have a steady hand, keep the lower point of the pipette always below the surface of the liquor, and cease to suck at the moment you perceive the liquor above the mark on the neck of the pipette; or you can attach a short caoutchouc tube to the top of the pipette, and regulate the flow of liquor by pinching the tube. Having filled the pipette above the mark, hold it steadily before you, fix your eye upon the mark, gently lessen the pressure on the tube, and let the excess of liquor run out, till the curve formed by its surface touches the mark. Then remove the pipette to the receiving-vessel and deliver its contents. When using the narrow pipette, fig. 83, the liquor should be adjusted to some specific number, such as 5 or 10, and then the number of septems required should be slowly dropped out and counted as they fall. The bottom septem of such a pipette cannot deliver its contents accurately. All quantities must therefore be measured in the middle of the pipette.

By means of these instruments, solutions of acids, alkalies, and salts may be prepared of any desired degree of strength—the *limit of the strength of each being the solubility of the substance in water at 62° F.* The test atom of any substance can be easily divided into 100 or any smaller number of equal parts, or any fractional quantity of a test atom may be taken that is desirable for any particular purpose. With the addition of a few other glass vessels, these instruments afford the means of testing the strength and purity of alkalies, acids, solutions of metals, and many other articles of importance in the arts.

PREPARATION OF STANDARD SOLUTIONS.

I proceed to describe the processes employed to prepare standard solutions of acids and alcalies. These solutions form the basis of the system of centigrade testing, and they must be prepared with great accuracy. The rule to be followed is this: *to form a test liquor of 5°*, which is a very convenient strength for general purposes, dissolve five test atoms of the chemical preparation in so much water as will make a decigallon of solution at 62° Fahr. The table at page 19 gives the weights of the test atoms. What we have to study now is the practical means of weighing them and bringing them into solution; so as to secure the proper proportions of test and water.

CARBONATE OF POTASH OF $2\frac{1}{2}^{\circ}$.—The carbonates being bibasic solutions of $2\frac{1}{2}^{\circ}$ are equal in saturating power to acid solutions of 5°. See pages 107 and 114. Expose about 400 grains of pure carbonate of potash, in a porcelain crucible, to a red heat over a spirit lamp or gas light, to expel water from it. After 10 minutes' ignition remove the crucible from the spirit lamp, and let it cool, closely covered. In the meantime, counterpoise a large thin dry and warm porcelain crucible, containing 345 grains in weights. When the ignited carbonate of potash is cool enough to be weighed, remove the weights, and in their place put as much of the ignited salt as restores the equilibrium of the counterpoise. Transfer the weighed salt from the crucible into the decigallon measure, fig. 71, page 97. Add about 10 ounces of pure water, shake the vessel to diffuse the heat, and add more water till the vessel is *nearly* filled up to the mark *a, b*. It must then rest till the temperature of the solution sinks to exactly 62° F., which must be tried by a thermometer. When the liquor is come to that temperature, water is to be added by means of a dropping tube, till the measure is completed. This is the case when the engraved line *a, b*, coincides with the lower part of the curve formed by the surface of the liquor in the bottle. Cover the mouth of the bottle with a piece of thin writing paper, close it tight with the palm of your hand, and shake the bottle to mix the solution thoroughly. It may then be decanted into a stoppered bottle. It will have the strength shown by No. 13, in the table on page 114. This solution may be used in preparing test acids of 5°, with which it is equivalent measure for measure.

CARBONATE OF SODA OF $2\frac{1}{2}^{\circ}$.—A normal solution of this salt is prepared precisely in the same manner as the normal solution of carbonate of potash of $2\frac{1}{2}^{\circ}$. Expose about 300 grains of the pure anhydrous salt, in a porcelain crucible, to a red heat for ten minutes. As soon as it is cool, weigh out 265 grains. Dissolve this in distilled water in the decigallon bottle, fig. 71, dilute the solution nearly to the mark *a, b*, bring the temperature of it to 62° F., and then adjust the measure

exactly to the mark. The strength is shown by No. 14 in the table on page 114.

It is of the utmost consequence to prepare this solution with every attention to accuracy, because it is to form the standard for the strength of your acids, and indirectly of your alcalies, and if your normal solution of soda is inaccurate, all your subsequent analyses of acids and alcalies will be inaccurate in the same degree.

SULPHURIC ACID OF 5°.—Prepare a solution of *carbonate of soda* of 2½°, as described under that article.



84.



85.



86.

Take of that solution 100 septems, by means of the centigallon pipette, figs. 81 or 86. Put it into a conical mixing jar, fig. 84, or into a wide-necked flask, fig. 78 g. Add six drops of tincture of litmus. This is most conveniently done by means of a bottle pipette, such as fig. 85. Fill your centigrade alcalimeter with diluted sulphuric acid containing one part of oil of vitriol mixed with about 20 parts of water. This mixture is to be made by putting the water into a thin glass flask, *adding the acid to the water gradually*, and allowing the mixture to cool to 62° F. Neutralise the 100 septems of solution of soda with acid poured from the alcalimeter, and ascertain how many septems of acid are required. In doing this the following points are to be attended to carefully.

Place a sheet of white paper below the flask or jar, to enable you to see the changes of colour that occur. Add the acid in quantities of about four septems at a time. Shake the jar with a circular motion to facilitate the mixture. After a time the blue litmus becomes of a pale claret colour. The jar must now be placed over a spirit lamp until the mixture becomes boiling hot. The acid is then to be slowly added, one or two drops at a time, until the colour of the litmus changes from claret red to a pale scarlet colour. The purpose for which the liquor is made boiling hot, is to expel the carbonic acid gas that is liberated from the carbonate of soda by the action of the sulphuric acid. Carbonic acid gives to litmus a claret or crimson tinge, sulphuric acid gives it a scarlet-red hue. Towards the end of the neutralisation, after every addition of one drop of the acid and agitation of the liquor, a drop of it is to be taken on the fine point of a glass rod and applied to a piece of blue litmus paper. As soon as the alkali is perfectly neutralised, and the liquor contains the least excess of acid, the litmus paper turns red where touched by the wetted glass rod.

The number of septems of the diluted acid that are required to

neutralise the soda, shows the number of septems of the acid that contain one-tenth part of five test atoms of sulphuric acid, or that quantity which will form 100 septems of solution of 5° . The experiment must be repeated with great care, that you may be quite certain what this number is. I shall suppose it to be 40 septems. In that case, all that it is necessary to do to produce sulphuric acid of 5° , is to put 40 measures of the diluted acid into the test-mixer, fig. 79, page 101, and to add as much water as dilutes the 40 measures to 100 measures.

This dilution is to be effected with certain precautions. Supposing the test-mixer to contain 1000 septems, at first you add to 400 septems of the diluted acid about 400 septems of water. Then put in the stopper, and shake the mixture. Afterwards you add more water, at two or three times, until the measure is equal to 990 septems. The mixture is left to cool to the temperature of 62° F., which must be tried by a thermometer. When this temperature is attained, water is slowly added, at first 3 or 4 septems, and the remainder by a dropping tube that cannot deliver above 1 drop at a time, till the measure is exactly 1000 septems. This adjustment requires care, because not one drop of water must be added in excess.

OXALIC ACID OF 5° .—A test atom of crystallised oxalic acid weighs 63 grains; 5 test atoms weigh 315 grains. Take 315 grains of clean dry crystals of pure oxalic acid, dissolve them in the decigallon bottle, fig. 71, in water, and dilute the solution, at 62° F., to the bulk of a decigallon. It has, then, a strength of 5° ; consequently, one measure of it will neutralise one measure of carbonate of soda of $2\frac{1}{2}^{\circ}$.

The standard solutions of carbonate of soda and of oxalic acid may be considered to be the two bases of the entire system of tests, because all other alkaline and acid solutions are prepared or tested by means of these, and it is, perhaps, a matter of indifference which of these solutions you take for a standard. Yet, while Dr. Mohr prefers oxalic acid, I prefer carbonate of soda.

SOLUBILITY OF ACIDS AND ALKALIES.—In studying the action of equivalent test liquors, it is useful to know the degrees of solubility of those chemical compounds whose frequent recurrence renders them important.

I have observed at page 102, that solutions may be prepared of any degree of strength, consistent with the solubility of the respective substances in water. Generally speaking, the most soluble substances are the free acids and free alkalies. The limits of solubility of the most important of these are stated in the tables at pages 106 and 107.



TABLE OF THE SOLUBILITY OF ACIDS IN WATER.
Temperature 62° Fahrenheit.

Grains of Oxalic Acid, HCO_2 , in one Septem.	Grains of Muriatic Acid, HCl , in one Septem.	Grains of Acetic Acid, $\text{H}_2\text{C}^2\text{H}^3\text{O}^2$, in one Septem.	Grains of Nitric Acid, HNO_3 , in one Septem.	Grains of Sulphuric Acid, HSO_2 , in one Septem.	Test Atoms in one Decigallon, or 1000 Septems.	Septems containing one Test Atom.
				12·921	263·7	3·79
				12·74	260·	3·85
				12·25	250·	4·
				11·76	240·	4·17
				11·27	230·	4·35
				10·78	220·	4·55
				10·29	210·	4·76
				9·8	200·	5·
				9·31	190·	5·26
				8·82	180·	5·56
				8·33	170·	5·88
			10·647	8·281	169·	5·92
			10·08	7·84	160·	6·25
			9·45	7·35	150·	6·67
			8·82	6·86	140·	7·14
			8·19	6·37	130·	7·69
		7·41	7·781	6·052	123·5	8·1
		7·2	7·56	5·88	120·	8·33
		6·6	6·93	5·39	110·	9·09
		6·	6·3	4·9	100·	10·
	3·431	5·64	5·922	4·606	94·	10·6
	3·285	5·4	5·67	4·41	90·	11·1
	2·92	4·8	5·04	3·92	80·	12·5
	2·555	4·2	4·41	3·43	70·	14·3
	2·19	3·6	3·78	2·94	60·	16·7
	1·825	3·	3·15	2·45	50·	20·
	1·46	2·4	2·52	1·96	40·	25·
	1·095	1·8	1·89	1·47	30·	33·3
	·73	1·2	1·26	·98	20·	50·
	·5475	·9	·945	·735	15·	66·7
·5345	·4336	·713	·748	·582	11·88	84·2
·45	·365	·6	·63	·49	10·	100·
·225	·1825	·3	·315	·245	5·	200·
·09	·073	·12	·126	·098	2·	500·
·045	·0365	·06	·053	·049	1·	1000·
45	36·5	60	63	49	Weights of Test Atoms.	

TABLE OF THE SOLUBILITY OF ALCALIES IN WATER.
Temperature 62° Fahrenheit.

Grains of Carbonate of Soda, Na ² CO ³ , in one Septem.	Grains of Carbonate of Potash, K ² CO ³ , in one Septem.	Grains of Caustic Soda, NaHO, in one Septem.	Grains of Caustic Potash, KHO, in one Septem.	Grains of Anhydrous Ammonia, NH ³ , in one Septem.	Test Atoms in one Decigallon, or 1000 Septems.	Septems containing one Test Atom.
				2·125	125·	8·
				2·04	120·	8·33
				1·87	110·	9·09
			5·694	1·728	101·67	9·83
			5·6	1·7	100·	10·
			5·04	1·53	90·	11·1
		3·53	4·94	1·5	88·25	11·3
		3·2	4·48	1·36	80·	12·5
		2·8	3·92	1·19	70·	14·3
		2·4	3·36	1·02	60·	16·7
		2·	2·8	·85	50·	20·
	5·764	1·67	2·34	·71	41·77	23·9
	5·52	1·6	2·24	·68	40·	25·
	4·14	1·2	1·68	·51	30·	33·3
	2·76	·8	1·12	·34	20·	50·
	2·07	·6	·84	·255	15·	66·7
1·236	1·61	·47	·653	·198	11·66	85·8
1·06	1·38	·4	·56	·17	10·	100·
·53	·69	·2	·28	·085	5·	200·
·212	·276	·08	·112	·034	2·	500·
·106	·138	·04	·056	·017	1·	1000·
106 Bibasic.	138 Bibasic.	40 Monobasic.	56 Monobasic.	17 Monobasic.	Weights of Test Atoms.	

The Carbonates, being bibasic, neutralise twice as much acid as the monobasic Alcalies of the same degree, measure for measure. Consequently, if monobasic solutions of 5 test atoms per decigallon are adopted as standards, EQUIVALENT solutions of the carbonates must contain only 2½ test atoms per decigallon. See page 114.

Example:—

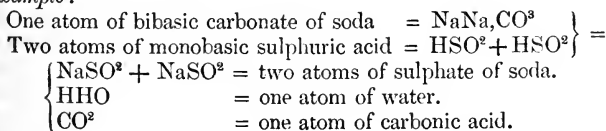

These Tables show the limits of solubility of the substances to which they refer. They show what degrees of strength are possible, and what are impossible. You can have sulphuric acid in the state of pure oil of vitriol of 264° . On the other hand, you cannot have oxalic acid of greater strength than 12° . It is curious to see that the solubility of the three mineral acids is nearly as the ratio of 1, 2, 3, namely:—

Muriatic Acid	.	.	.	94°
Nitric Acid	.	.	.	169°
Sulphuric Acid	.	.	.	264°

Considerable differences occur also among the alcalies. Ammonia can be made of 125° , but carbonate of soda not stronger than 12° .

The sixth column of the Tables shows the DEGREE of strength, or the number of TEST ATOMS per decigallon of each acid or alcali, that is equivalent to the weights named under the respective heads in the preceding columns.

The seventh column contains information of great importance for the preparation of dilute tests, namely, it states *the quantity, in septems, of each liquor, which contains one test atom*, and it applies equally to all the substances named in the Tables. These numbers are found by dividing 1000 by the number which represents the degree of each liquor. The mathematical scholar will find the numbers readily by means of a table of Reciprocals. I shall give such a table in a subsequent section.

I call this number the ATOMIC MEASURE of a test solution.

PREPARATION OF EQUIVALENT TEST LIQUORS.

ALCALIES.



88.

Determination of the Chemical Strength of Liquid Ammonia.—4 septems of the ammonia to be tried are mixed with 100 septems of water and 6 drops of solution of litmus. Use a wide-necked white glass bottle, fig. 88. The centigrade test-tube is to be filled with sulphuric acid of 5° , and the alcali is to be neutralised with all the precautions described in relation to sulphuric acid, page 104, excepting that, as no carbonic acid is present, the mixture does not require to be heated. The operation is finished when the blue mixture suddenly becomes red.

The strongest solution of ammonia at 62° F. contains 125° of ammonia, and 4 septems of such a solution contain half a test atom of ammonia. See page 107. This quantity of ammonia demands for its neutralisation 100 septems of sulphuric acid of 5° . All weaker solutions of ammonia require, of course, a smaller quantity of acid for their neutralisation.

In calculating the *result* of this analysis, the number of septems of

sulphuric acid which is required to neutralise the 4 septems of ammonia is first to be divided by 4, and then to be multiplied by 5. The product is the chemical strength of the ammonia expressed in test atoms.

Suppose the 4 septems of ammonia to require 100 septems of sulphuric acid of 5°, to neutralise them. We divide 100 by 4, to find how many septems of this acid are equal to 1 septem of the ammonia, and we find it to be 25. But the acid is of 5° of strength; and we multiply 25 by 5, to find the equivalent in septems of acid of only 1° of strength. The number we obtain is 125. Consequently, one septem of this ammonia will neutralise 125 septems of acid of 1°, or, in other words, the strength of the ammonia is 125°.

Again, suppose the 4 septems of ammonia to be neutralised by 96 septems of acid of 5°, then $96 \div 4 = 24$, and $24 \times 5 = 120$, which is the degree of the strongest commercial ammonia, the specific gravity of which, calculated by the rule given below, is

$$1000 - 120 = 880.$$

PREPARATION OF AMMONIA OF 5°.—Having determined by experiment the *degree* of your solution of ammonia, which I shall assume to be 120°, you have next to find its *atomic measure*, or the quantity of it, which contains 1 test atom of anhydrous ammonia. This, as I have stated in page 108, is done by dividing 1000 by the number that expresses the degree. Now $1000 \div 120 = 8.33$. Hence, to prepare a solution of 5°, you have to take 5 times $8.33 = 41.65$ septems of the strong ammonia and dilute it in the test-mixer to 1000 septems. It is then a solution of 5°.

AMMONIA-METER.—In commerce, liquid ammonia is usually valued according to its specific gravity. The hydrometer, however, indicates the strength of liquid ammonia in a very rough way; for 5 test atoms of ammonia per decigallon mark only 1 degree of a scale like that of Twaddell's hydrometer. I have recently contrived a hydrometer which has a convenient scale, when such a mode of testing is considered sufficiently precise. I have shown that at 62° F. a decigallon of the strongest ammonia contains 125 test atoms. The *ammonia-meter* contains 125°, each of which indicates 1 test atom of ammoniacal gas per decigallon of solution, or 170 grains per gallon.

This instrument is represented by fig. 89. A very extended table has been prepared to accompany it for the use of dealers in ammonia; it shows the weight of dry ammonia per gallon and per pound at every degree, and the corresponding money value of each solution.



89.

The relation of the specific gravity to the chemical strength of solutions of ammonia is remarkably simple. If the chemical strength is estimated in test atoms, and the specific gravity is written to three places of decimals, then the numbers which express the two powers are in all cases equal to 1000. Thus the specific gravity of ammonia of 125° is $\cdot 875$; that of 120° is $\cdot 880$, &c. See the subsequent article on Ammonia.

CAUSTIC POTASH OF 5° .—CAUSTIC SODA OF 5° .—A strong solution of caustic potash, or caustic soda, is to be tested in the same manner as the solution of ammonia. The degree having been found by experiment, the atomic measure is calculated, and dilution of 5 test atoms to 1000 measures is effected in the test-mixer.

ACIDS.

DETERMINATION OF THE CHEMICAL STRENGTH OF A SAMPLE OF NITRIC ACID.—*Process.*—Put into a flask of the capacity of 3 or 4 ounces, 100 septems of water. Add 6 drops of solution of litmus, then by means of the graduated pipette,



90.

fig. 83, page 102, put into the flask 5 septems of the nitric acid which is to be tested, and shake the mixture, which will have a bright-red colour. Fill the centigrade test tube with solution of ammonia of 10° of strength. Adjust the measure accurately to 0° . To do this easily, you may fill it rather above the mark, grease the lip of the test tube to prevent the liquor flowing down the outside, and pour the extra ammonia back into its bottle, drop by drop, till the proper measure is obtained. The next step is to neutralise the nitric acid with the ammonia, which is to be poured from the graduated tube into the flask in small portions of 2 or 3 septems at a time. After each addition of ammonia, the flask is to be shaken. When the bright-red colour of the acid begins to appear a little fainter, the ammonia must be added in quantities of 2 drops at a time. At last the red colour is suddenly converted into blue, at which point the acid is totally neutralised.

Result.—Having determined how many septems of solution of ammonia of 10° is required to neutralise 5 septems of nitric acid, the degree so found is to be divided by five, and then multiplied by 10, which gives its strength in test atoms. Suppose the nitric acid to be so strong that the 5 septems of it require for neutralisation no less than 84 septems of ammonia of 10° , then we have these calculations:—

$$84 \div 5 = 16.8 \text{ and } 16.8 \times 10 = 168.$$

Hence the nitric acid is of the strength of 168 test atoms per decigallon, or is within 1° the strongest possible at 62° F., as shown by the table at page 106.

PREPARATION OF NITRIC ACID OF 5°. You take nitric acid of any strength, and test its degree in the manner just described. I assume that you find the degree to be 165°, you then calculate the atomic measure, by dividing 1000 by the degree. $1000 \div 165 = 6.06$. Hence 5 times 6.06, say $30\frac{1}{3}$ septems of the strong acid, diluted with water in the test-mixer till it forms 1000 septems, produces nitric acid of 5°.

NITRIC ACID OF 10°.—After finding the strength of your nitric acid, as just described, take ten times 6.06 septems, or say $60\frac{2}{3}$ septems, and dilute it in the test-mixer to 1000 septems. It has then the strength of 10°.

MURIATIC ACID OF 10°.—Muriatic acid of 10° is prepared exactly in the same manner as nitric acid of that strength. This acid is required for testing limestones, and other substances that produce insoluble salts with sulphuric and oxalic acids.

GENERAL OBSERVATIONS ON THE PROCESS FOR TESTING THE STRENGTH OF ACIDS AND ALCALIES.—One test acid is sufficient for testing all the alcalies, and one test alkali for testing all the acids. 5° is a useful strength, but acids of 10°, 20°, 30°, &c., are required for other purposes. The choice of the test acid lies between sulphuric acid and oxalic acid. The former is much the cheapest of the two, and I think, on the whole, is preferable to the latter. The solution of oxalic acid can be made directly from the pure crystals. The former requires the use of pure carbonate of potash or of soda. But this is a disadvantage which is only felt in the preparation of the first solution, since all others are made by testing with caustic alkali.

The standard alkali may be either ammonia or caustic potash. I find that a solution of the former of 5° can be kept a considerable time in a cool place without much alteration. The caustic potash does not suffer a loss of strength, from the volatilisation of the alkali, and is preferable on that account. It can only be used, however, with Mohr's form of alcalimeter, fig. 78. None of the alcalimeters which have the spout at the top can be used with caustic potash. The reason is, that those alcalimeters require to have the spout greased with tallow, to hinder the test liquor from running down the outside of the tube, and caustic potash (and caustic soda also) washes the tallow away. Caustic soda has the disagreeable property of acting upon the graduated glass tubes.

When the standard test solutions and the apparatus are in good order, the analysis of acids and alcalies can be effected with very small quantities of liquor. 5 septems of a strong solution, or 10 septems of a weak solution, is commonly enough to operate upon. The best plan for general procedure is to begin with 5 septems, and neutralise it rapidly. You thus get a rough estimate of the strength of the liquor; after which you repeat the experiment carefully with 5 or 10 septems.

In all the preceding examples, I have given the method of calculating results in such a manner as to lead to the preparation of standard solutions of particular *degrees of strength*. But it often happens, in analytical processes, that you want to know the *exact weight* of some component of a substance submitted to examination. I have thrown into the form of a table some examples to show the manner in which experiments of this sort are to be managed. See the Table on pages 114 and 115.

Example.—Neutralise a small quantity—by weight if solid, or by measure if liquid—of one of the acids named in the table from 1 to 7, using a test alkali of 5° with an alcalimeter. Observe how many septems of test alkali are required. Let it be 30. Then, under the head of 3 *septems* in the table, and on the horizontal line of the acid submitted to examination, you find a number, which, after the removal of the decimal point, one place to the right hand—to convert 3 septems into 30—show the *number of grains of the acid contained in the quantity that was submitted to the test*. Thus, if the subject of assay was acetic acid, it contained 9 grains of acid. If it was tartaric acid, the quantity was 11.25 grains. In like manner, the weight of an alkali can be reckoned from the quantity of test acid required to neutralise it.

APPLICATION OF THE PRINCIPLES OF CENTIGRADE TESTING TO MERCANTILE AND MANUFACTURING OPERATIONS.—The process of centigrade testing is employed as an easy and rapid method of analysis, to direct the operations of the manufacturing chemist, or to determine the commercial value of his products. It is therefore used to determine the strength of the liquid acids, the purity of carbonate of soda, the bleaching powder of chloride of lime, and for the solution of numerous other technical problems upon which my space does not permit me to enter into details; but I shall give two or three examples to show the method and importance of such operations.

Testing of Impure Carbonate of Soda.—Commercial carbonate of soda contains water and neutral salts. The object of the analysis is to find how much carbonate of soda it contains. Weigh out $2\frac{1}{2}$ atoms, namely, 265 grains, of the impure carbonate of soda, and make with it a decigallon of solution, in the manner described at page 103. Then measure off 100 septems of the solution, and test it with sulphuric acid of 5°, in the manner described at page 104. The number of septems of test acid used shows the per centage of carbonate of soda contained in the impure sample.

Testing of Vinegar.—Take 50 septems of vinegar, dilute it with its bulk of pure water, add a few drops of litmus, and neutralise it with test alkali of 5°. Observe the number of septems required, and divide that number by 50 and multiply it by 5, or, what comes to the same result, divide it by 10. The product is the degree of the vinegar. If the number of septems is 50, then $50 \div 50 = 1$, and $1 \times 5 = 5$; so

also $50 \div 10 = 5$; which is the strength of the vinegar in test atoms per decigallon. The strength of good vinegar is about $6\frac{1}{4}$ degrees.

Testing of Limestone and Marls.—The value of limestone commonly depends upon the quantity of carbonate of lime which it contains. This is true, whether the limestone is to be used as a flux for ironstone in the blast furnace, or to be burnt for mortar or for manure. Marls usually contain from 50 to 80 per cent. of carbonate of lime, the residue consisting of sand or clay. On the contrary, fine English chalk and Irish limestone are almost pure carbonate of lime.

The following method of testing limestones is extremely easy, and gives very good results. The flask must be chosen of about the capacity of 6 ounces of water, and with a cylindrical neck, about 6 inches long and 1 inch in diameter. The flask may have the form of fig. 91 *a*, or fig. 92, but it must be thin at the bottom, to bear exposure over a spirit lamp. Fig. 91 *b*, is a tube of thin glass, that fits the neck of the flask pretty close, but slips easily up and down; it is filled with cold water, and stopped by a large cork, *c*.

Weigh out on a watch-glass, for analysis, 50 grains of the limestone, previously reduced in a porcelain mortar to a fine powder. Put into the flask *a*, 100 septems of muriatic acid of 10° . To do this easily and accurately, use a pipette of the form of fig. 93, graduated to deliver 100 septems. Dip this into the prepared acid, adjust the measure, and then transfer the pipette to

the flask *a*, without soiling the neck of the flask. Add the pulverised limestone gradually to the muriatic acid, agitating the mixture after every addition of powder. When the powder has been all added, if any of it sticks about the neck of the flask, it must be washed down into the acid by means of a washing-bottle. Put the tube *b* into the flask, and apply heat to the flask by means of the spirit-lamp. This completes the action of the acid on the limestone, and expels the disengaged carbonic acid, which lifts up the tube *b*, and escapes. The cold water is intended to condense any vapour of muriatic acid that may be produced by the heat, and so prevent its escape from the flask. When the liquor has been raised to a boiling heat, the flask may be removed from the lamp. The outside of the tube *b* is to be washed by the spiriting bottle, and the washings added to the contents of the flask. Add 6 drops of solution of litmus to the mixture, which will become

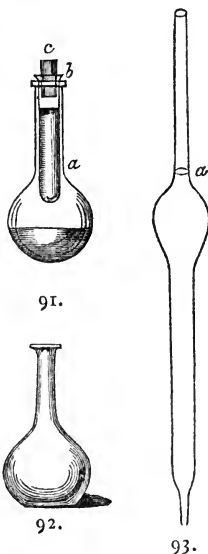
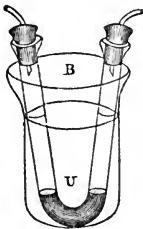

TABLE OF TEST EQUIVALENTS,

		Weight of 1 Test Atom.	Weight of 5 Test Atoms.	
1	Acetic Acid	$\text{H}_2\text{C}^2\text{H}^3\text{O}^2$	60·	300·
2	Muriatic Acid	HCl	36·5	182·5
3	Nitric Acid	HNO^3	63·	315·
4	Oxalic Acid	HCO^2	45·	225·
5	— — <i>crystallised</i>	HCO^2, HHO	63·	315·
6	Sulphuric Acid	HSO^2	49·	245·
7	Tartaric Acid, <i>crystallised</i>	$\text{H}_2\text{C}^2\text{H}^3\text{O}^4$	75·	375·
8	Carbonic Acid	CO^2	44·	220·
9	Ammonia	NH^3	17·	85·
10	Potash, hydrate	KHO	56·	280·
11	Soda, hydrate	NaHO	40·	200·
12	Lime, hydrate	CaHO	37·	185·
13	Potash, carbonate * $2\frac{1}{2}$ atoms	K^2CO^3	138·	345·*
14	Soda, carbonate * $2\frac{1}{2}$ atoms	Na^2CO^3	106·	265·*

red, and then, by means of a centigrade test-tube, add solution of ammonia or potash of 10° until the mixture turns blue. *Result.*—Every septem of ammonia required to be added to neutralise the mixture in the flask, indicates 1 per cent. of impurity in the limestone. Thus, if 20 septems of ammonia are used, the limestone contains 80 per cent. of carbonate of lime. The reasons are obvious: 50 grains of carbonate of lime, 100 septems of acid of 10° , and 100 septems of ammonia of 10° , all contain equivalent quantities of the respective reagents, provided all are pure. Hence, if carbonate of lime is deficient, the ammonia supplies its place and indicates the quantity *per cent.*



94.

TESTING OF AMMONIA.—In the examination of impure salts of ammonia, used for manure and other purposes, it is necessary to ascertain the quantity of ammonia. The impure compound is heated in a flask with a solution of caustic soda, which disengages ammonia in the state of gas. To determine the quantity of this ammonia, you collect it in such an apparatus as is represented by fig. 94, where U is a bent tube containing 100 septems of acid of 5° , and B a glass with cold water for condensation. Such a quantity of the ammoniacal compound must be operated upon as will liberate a smaller quantity of gas than 100 septems of acid of 5° can absorb. The table at page 115, column 1 septem, line 9, shows that that quantity of ammonia is 8·5 grains.

SOLUTIONS OF FIVE TEST ATOMS IN A DECIGALLON.

	1 Septem.	2 Septems.	3 Septems.	4 Septems.	5 Septems.	6 Septems.	7 Septems.	8 Septems.	9 Septems.
1	·3	·6	·9	1·2	1·5	1·8	2·1	2·4	2·7
2	·1825	·365	·5475	·73	·9125	1·095	1·2775	1·46	1·6425
3	·315	·63	·945	1·26	1·575	1·89	2·205	2·52	2·835
4	·225	·45	·675	·9	1·125	1·35	1·575	1·8	2·025
5	·315	·63	·945	1·26	1·575	1·89	2·205	2·52	2·835
6	·245	·49	·735	·98	1·225	1·47	1·715	1·96	2·205
7	·375	·75	1·125	1·5	1·875	2·25	2·625	3·	3·375
8	·22	·44	·66	·88	1·1	1·32	1·54	1·76	1·98
9	·085	·17	·255	·34	·425	·51	·595	·68	·765
10	·28	·56	·84	1·12	1·4	1·68	1·96	2·24	2·52
11	·2	·4	·6	·8	1·	1·2	1·4	1·6	1·8
12	·185	·37	·555	·74	·925	1·11	1·295	1·48	1·665
13	·345	·69	1·035	1·38	1·725	2·07	2·415	2·76	3·105
14	·265	·53	·795	1·06	1·325	1·59	1·855	2·12	2·385

At the end of the distillation, the excess of acid must be neutralised by test alkali of 5° , and the number of septems of test alkali being deducted from 100, the residue shows the equivalent of ammonia. Thus, if 30 septems of alkali are required, the ammonia must have neutralised 70 septems of test acid, and, according to the table at page 115, column 7 septems, line 9, that indicates the presence of 5·95 grains of ammonia.

In the analysis of guano, the nitrogen it contains is converted into ammonia by ignition with soda and lime; but the ammonia, when disengaged, can be estimated in this manner.

MISCELLANEOUS EXPERIMENTS WITH EQUIVALENT TEST LIQUORS.

A great variety of salts can be quickly and economically prepared in small quantities for examination by tests, &c., by this process, which is therefore strongly recommended to students. Solutions of the principal acids, alcalies, and alkaline carbonates, all of 10° or of 5° of strength, are first prepared by the processes described under the respective articles, setting out with the normal solution of carbonate of soda, described at page 103. Solutions of the principal salts should also be prepared of 10° , 5° , or 1° of strength. But as, of such solutions, a student will not require so large a quantity as a decigallon, he should be provided with a centigallon (100 septems) test-mixer of the form shown by fig. 80, page 101, or with a bottle like fig. 95, which holds 100 septems when filled up to a mark on the neck. To prepare solutions

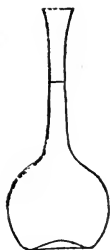

95.

of 1° with this instrument, $\frac{1}{10}$ part of a test atom of each salt is required for 100 septems of solution. That is to say, the numbers in the table at page 19 require the decimal point to be moved one figure to the left. Thus, 12.2 grains of crystallised chloride of barium will give 1 centigallon of solution of 1° at 62° F.—A bottle of this sort, graduated to 250 septems, requires $\frac{1}{4}$ of a test atom of the salt, and gives 4 fluid ounces of solution.—When the student has prepared a series of such solutions, he can proceed to make a series of other salts as follows:—By adding 10 septems of sulphuric acid of 10° to 10 septems of solution of potash of 10° . The measure is best effected by a pipette, graduated so as to deliver 10 septems of liquid, independently of what adheres to the tube, fig. 82. The mixture may be made in a capsule of glass or porcelain, in which the product can be evaporated for the purpose of crystallisation. No filtration is necessary, because the liquors are all considered to be pure. The above mixture yields, if the operation is correctly performed, neutral sulphate of potash, the quantity of which should agree with the indications of the table at page 114. 10 septems of sulphuric acid of 10° contain 4.9 grains of the acid HSO^3 , and the same quantity of solution of caustic potash of 10° contains 5.6 grains of the alkali KHO . The sulphate of potash produced by their mixture should therefore weigh $4.9 + 5.6 - 1.8$ ($\frac{1}{10}$ atom of water) = 8.7 grains. The decomposition is as follows: $\text{HSO}^3 + \text{KHO} = \text{KSO}^3 + \text{HHO}$.—Other salts may be produced in a similar way. If 10 septems of muriatic acid of 10° are put into a test tube, and 5 grains of pure calcareous spar are added, and the liquor is boiled when the effervescence ceases, the muriatic acid should be entirely neutralised, and the liquor contain neutral chloride of calcium. For 10 septems of acid of 10° is the 10th part of a test atom, and 5 grains of calc spar is the 20th part of a test atom, and these are therefore equivalent quantities.—If the resulting solution of chloride of calcium is diluted with water to the bulk of 100 septems, then the solution will be of 1° of strength, and 10 septems of it should be exactly precipitated by 10 septems of solution of nitrate of silver of 1° of strength.

In the same manner 10 septems of nitric acid of 10° should dissolve the 10th part of a test atom, namely, 3.175 grains, of metallic copper, producing the 10th part of a test atom of nitrate of copper. The various compounds that may thus be formed can be evaporated and crystallised, or preserved in the liquid state, or be tested by the reagents, or be converted by double decomposition into other salts. Thus 10 septems of chloride of barium of 10° mixed with 10 septems of sulphate of soda of 10° will be totally decomposed, producing the 10th part of a test atom of insoluble sulphate of barytes, and the 10th part of a test

atom of soluble chloride of sodium. By filtration, washing, and evaporation to dryness, both may be obtained separately in the solid state. It is quite evident that a vast number of accurate experiments may thus be performed with facility and great economy.

EXPERIMENTS WITH TEST LIQUORS OF 5°.

These experiments are to be performed in the manner just described. 10 septems of each liquor are to be measured by means of a graduated pipette, fig. 96. The liquors are to be mixed in a glass flask, fig. 97, or a beaked tumbler, fig. 98, both thin enough at the bottom to bear heating over a spirit-lamp. When there is a precipitate, it is to be collected on a paper filter placed in a glass funnel, fig. 99, and to be washed with pure water, by means of the washing-bottle, fig. 100, the water from which is expelled by the tube *b*, when you blow into the tube *a*. The washings are to be added to the solution, which is to be poured into a small porcelain evaporating basin, and to be evaporated as directed at page 55, that the salt it contains may crystallise. If you possess a microscope, a drop of the solution, with some of the precipitated salt, should be placed on a glass slider, and examined under the microscope. Sulphate of lime

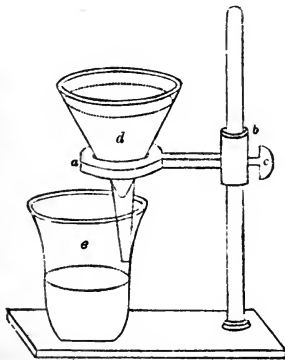
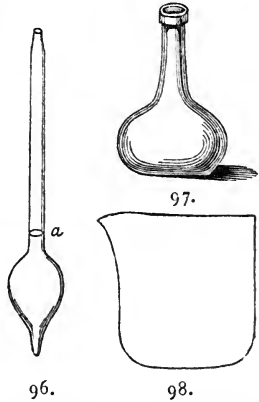

99.

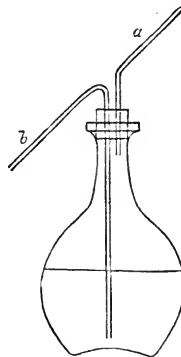

100.

and other precipitates often show very beautiful and characteristic

crystals. A drop of the filtered solution after concentration by heat should also be examined thus, when the forms of the different salts will be distinctly perceptible.

Experiments on the Composition of Salts.

1. Mix sulphuric acid with ammonia. Evaporate and crystallise. The product is sulphate of ammonia.
 2. Mix sulphuric acid and soda. Evaporate and crystallise. Product, sulphate of soda.
 3. Mix sulphuric acid and potash. Crystallise. Product, sulphate of potash.
 4. In the same way, muriatic acid and ammonia produce chloride of ammonium.
 5. Muriatic acid and soda produce chloride of sodium.
 6. Muriatic acid and potash produce chloride of potassium.
- Nos. 5 and 6 can be crystallised by slowly evaporating the water.
7. Nitric acid and ammonia produce nitrate of ammonia. Crystallise.
 8. Nitric acid and soda produce nitrate of soda. Crystallise.
 9. Nitric acid and potash produce nitrate of potash. Crystallise.
 10. The salts produced by mixing caustic alcalies with acids can also be produced by mixing the carbonates of the alcalies with acids, the carbonic acid being discharged in the state of gas.
 11. When equal measures of an acid and an alkaline test solution of the same degree are mixed together, the resulting solution has only *half the degree* of the components. 1000 septems of sulphuric acid of 10° , and 1000 septems of soda of 10° , produce 2000 septems of sulphate of soda of 5° ; because there is present in all only 10 test atoms of sulphate of soda, and that is dissolved in 2000 septems of solution.

Double Decomposition of Salts.

In these experiments use 10 septems (or, if you prefer it, 25 septems) of each liquor. Boil the mixture and let it cool. The precipitates are to be separated by filtration, and the salts remaining in solution are to be crystallised. Double decomposition of salts, effected by equivalent quantities of solution, is rarely quite complete. Sometimes part of one of the original salts is carried down by the precipitate: sometimes part of what should precipitate remains dissolved in the mother liquor. Nevertheless, this set of experiments gives very striking and instructive results.

12. Mix sulphate of soda and chloride of calcium. Boil. Products, sulphate of lime crystallised, and chloride of sodium in solution.
13. Mix sulphate of soda and nitrate of lime. Products, sulphate of lime crystallised, and nitrate of soda in solution.
14. Mix sulphate of soda and chloride of barium. Products, sulphate of barytes in powder, and chloride of sodium in solution.

Experiments with Phosphate of Soda of 1°.

15. Mix 5 measures of this solution with 1 measure of chloride of calcium of 5°. Product, phosphate of lime precipitated and chloride of sodium in solution.

16. Mix 5 measures of the phosphate of soda of 1° with 1 measure of nitrate of lime of 5°. Product, phosphate of lime precipitated and nitrate of soda in solution.

These experiments give examples of the manner in which the nature and relations of *saline manures* may be explained in schools where agricultural chemistry is taught.

The teacher can not only show the substances in their crystallised condition, and say, "This is nitrate of soda—this is sulphate of soda—that is gypsum," &c., but he can demonstrate the properties of the proximate elements of these salts; he can exhibit experimentally the differences between acids and bases, and can use the tests by which the individuals of each class are severally identified. He can then with facility and certainty *compose the salts* before the eyes of the pupils, making common salt and nitre, and glauher's salts and sal-ammoniac, by the mixture of corrosive acids and alcalies; and producing insoluble gypsum and bone-earth by the mixture of limpid solutions. It cannot be doubted that, in agricultural schools, experiments of this practical kind, made, as they could be made, thoroughly intelligible to the pupils, would be productive of very beneficial results. The *nature* of the saline manures would be better comprehended, and the *cheating* practised by dealers in manures, would be in a great measure prevented. No young farmer who had performed, or had seen performed, the analytical experiments described in the preceding pages, would ever pay the price of guano for a mixture of brickdust and spent bark, or even pay the price of good saltpetre for a mixture containing forty per cent. of common salt—examples of agricultural economy which stand on record, and are perhaps not unfrequent. Teaching of this sort might induce farmers to let their sons remain at school a little longer than they are now contented to do for the sake of acquiring what they are apt to regard as unmarketable book learning.

Experiments with these equivalent test liquors might be multiplied to an indefinite extent. Besides those which depend upon the action of two such liquors, you can, on the one hand, take a given quantity of a test acid, say 10 septems ($\frac{1}{100}$ test atom), and act upon it with various metals, oxides, carbonates, &c., and ascertain the quantity of salt produced; and, on the other hand, you can, with the same quantity of a test alkali, examine the saturating powers of various acids, and the

quantity of salt thus produced. With little trouble and with little expense, you can in this manner carry out a very extensive series of chemical researches. You do not, indeed, make conflagrations and explosions at every step, you miss the thunder and lightning of the lecture-room, you escape from the hilarity of holiday chemistry; but you gradually acquire the knowledge, the resources, and the power of the philosophical chemist.

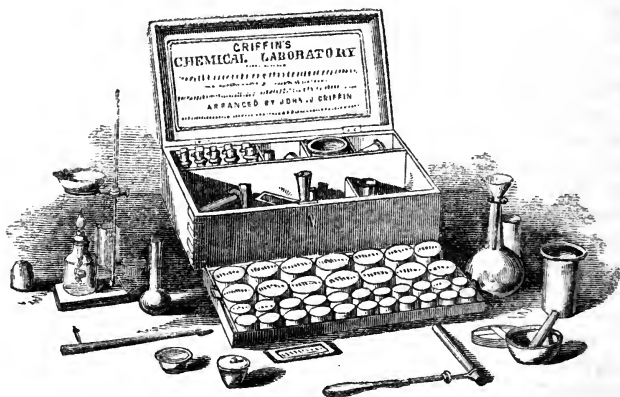

THE RADICAL THEORY.

ACCORDING to the Radical Theory, the chemical compounds which commonly bear the name of SALTS are not composed, as they are usually assumed to be composed, of *Acids* and *Bases*, but are held to be quite free from *Acids* and *Bases*, and to have for their proximate constituents substances which are called RADICALS.

Thus, for example, sulphate of lead is not to be considered as a compound of the base called oxide of lead = PbO , with the acid called sulphuric acid = SO^3 , but as a compound of the *Basic Radical* called Lead = Pb , with the *Acid Radical* called Sulphur = S , in connection with a certain quantity of Oxygen = O^2 . On the radical theory, the atomic weight of oxygen is doubled, which reduces the number of atoms present in this compound from four to two.

The notion that sulphate of lead contains oxide of lead combined with sulphuric acid is repudiated, because it cannot be proved, by experiment or by argument, to be true, and because, indeed, all existing evidence which bears upon the point tends more to disprove than to prove the truth of such an assumption. It can only be proved by experiment that the substance in question contains lead, and sulphur, and oxygen; but no evidence is available to show in what manner the oxygen is divided between the lead and the sulphur, or whether it is all fixed in combination with the one element or with the other. For these reasons, the advocates of the radical theory restrict themselves to the declaration that sulphate of lead is a compound of lead and sulphur, oxidised or combined with oxygen in some unknown manner, and they express this limited knowledge of the composition of the salt by writing the formula thus: $PbSO^2$, which states only to the least possible extent what is *conjectured* in addition to what is *known*.

Some reader may perhaps consider that this is a step rather backwards than forwards in chemical theory. He may think that the theory which is expressed in the formula PbO,SO^3 , is more exact, or, at any rate, more explanatory than that which is expressed by the formula $PbSO^2$. But he must bear in mind that chemistry is, or ought to be made to be, a *science of FACTS*, and that when, without knowledge or proof of truth, we assume that the oxygen which is present in sulphate of lead is absolutely divided in such a manner that one-fourth of it is combined with the lead and three-fourths of it with the sulphur, we quit the firm ground of certainty to plunge into the slough of conjec-

ture. We are no longer occupied with the science of facts, but wander in the region of fanciful plausibilities.

The Radical Theory, then, is an attempt to keep chemical reasoning connected as closely as possible with chemical facts, in order to restrain the practice of building flimsy scientific speculations upon insecure foundations—ornamenting the domain of chemistry with castles in the air.

Let it not be imagined that the discussion of this subject is unsuited to the pages of a work devoted to teaching the rudiments of the science. In the present condition of chemistry, the experimental part of which is becoming reduced to methods of great precision, while the theoretical part is flooded with hypotheses of the most discordant character—some of them sober and reasonable, some splendid but fantastic—it is essential for every student to acquire for himself, not only the art of patient examination of facts, but the power of independent judgment as to theories.

I shall state in a few words the principles of the Radical Theory, which will afterwards be illustrated by numerous examples. The point to which I wish particularly to direct the reader's attention, is, that the great phenomena and most important facts of chemistry can be more satisfactorily explained by the radical theory than by any other theory.

According to the radical theory, *Every Salt is composed of two Radicals. These radicals may be simple or compound. The salt may be oxidised or not oxidised.*

Every element, except oxygen, can act as a radical. Oxygen never acts as a simple radical, nor forms part of a compound radical. The quantity of an element which constitutes a radical is an atom, or as much as forms a single volume of gas. Some of the metallic elements form two radicals which differ in weight and properties. The following is a Table of the simple or elementary radicals, with their symbols and atomic weights. I have added to the Table the atomic weights adopted by Professor MILLER, to show the divarications in the instances where I admit that *one element can produce two different radicals*. The facts and arguments which justify this assumption—that one element can form two different chemical radicals—two combining atoms of different weights and different properties, each equivalent in chemical force to the other atom and to the radicals formed by every other element—are given at length in my treatise on the Radical Theory,¹ to which work I must refer those readers who wish to become thoroughly acquainted with this subject. I shall, however, bring forward in several chapters of this volume the principal facts and arguments which support this theory of double equivalents.

¹ *The Radical Theory in Chemistry.* By John J. Griffin. London, 1858.

EQUIVALENT WEIGHTS OF ELEMENTARY RADICALS.

ELEMENTS.	Symb.	Griffin.	Miller.	Abridged Names.
Aluminum	Al	13.5	13.7	Al- ous.
—	Alc	9.		Al- ic.
Antimony	Sb	120.	120.	Stib- ous.
—	Sbc	40.		Stib- ic.
Arsenic	As	75.	75.	Ars- ous.
—	Asc	25.		Ars- ic.
Barium	Ba	68.5	68.5	Baryt.
Bismuth	Bi	210.	213.	Bism- ous.
—	Bic	70.		Bism- ic.
Boron	B	3.5	10.9	Bor.
Bromine	Br	80.	80.	Brom.
Cadmium	Cd	56.	55.7	Cadm.
Calcium	Ca	20.	20.	Calc.
Carbon	C	12.	6.	Carb.
Cerium	Ce	46.	46.	Cer- ous.
—	Cec	30.66		Cer- ic.
Chlorine	Cl	35.5	35.5	Chlor.
Chromium	Cr	27.	26.3	Chrom- ous.
—	Cre	18.		Chrom- ic.
Cobalt	Co	29.5	29.5	Cob- ous.
—	Coc	19.66		Cob- ic.
Copper	Cu	63.5		Cupr- ous.
—	Cuc	31.75	31.75	Cupr- ic.
Didymium	D	48.	48.	Didym.
Erbium	E			Erb.
Fluorine	F	19.	19.	Fluor.
Glucinum	G	4.7	7.	Gluc.
Gold	Au	196.5	196.6	Aur- ous.
—	Auc	65.5		Aur- ic.
Hydrogen	H	1.	1.	Hydr.
Ilmenium	Il			Ilm.
Iodine	I	127.	127.	Iod.
Iridium	Ir	99.	98.6	Irid- ous.
—	Irc	66.		Irid- ic.
Iron	Fe	28.	28.	Ferr- ous.
—	Fec	18.66		Ferr- ic.
Lantanum	La	46.	46.	Lant.
Lead	Pb	103.5	103.6	Plumb.
Lithium	L	6.5	6.5	Lith.
Magnesium	Mg	12.	12.16	Magn.
Manganese	Mn	27.5	27.6	Mang- ous.
—	Mnc	18.33		Mang- ic.

ELEMENTS.	Symb.	Griffin.	Miller.	Abridged Names.
Mercury	Hg	200.		Mer- ous.
—	Hgc	100.	100.	Mer- ic.
Molybdenum	Mo	48.	45.	Molybd- ous.
—	Moc	16.		Molybd- ic.
Nickel	Ni	29.55	29.5	Niccol- ous.
—	Nic	19.66		Niccol- ic.
Niobium	Nb			Niob.
Nitrogen	N	14.	14.	Nitr.
Osmium	Os	99.5	99.4	Osm- ous.
—	Osc	66.33		Osm- ic.
Oxygen	O	16.	8.	Ox.
Palladium	Pd	53.2	53.2	Pall- ous.
—	Pdc	26.6		Pall- ic.
Pelopium	Pe			Pelop.
Phosphorus	P	31.	31.	Phosph.
Platinum	Pt	99.	98.6	Plat- ous.
—	Ptc	49.5		Plat-ic.
Potassium	K	39.	39.	Potass.
Rhodium	Rh	52.	52.2	Rhod- ous.
—	Rhc	34.66		Rhod- ic.
Ruthenium	Ru	52.	52.	Ruth- ous.
—	Ruc	34.66		Ruth- ic.
Selenium	Se	40.	39.6	Sel.
Silicon	Si	7.	14.24	Sil.
Silver	Ag	108.	108.	Argent.
Sodium	Na	23.	23.	Natr.
Strontium	Sr	44.	43.8	Stront.
Sulphur	S	16.	16.	Sulph.
Tantalum	Ta			Tant.
Tellurium	Te	64.	64.	Tellur- ous.
—	Tec	32.		Tellur- ic.
Terbium	Tb			Terb.
Thorium	Th	59.5	59.5	Thor.
Tin	Sn	59.	58.8	St- ous.
—	Snc	29.5		St- ic.
Titanium	Ti	12.	24.2	Tit.
Tungsten	W	92.	92.	Tungst.
Uranium	U	60.	60.	Ur- ous.
—	Uc	40.		Ur- ic.
Vanadium	V	68.4	68.5	V- ous.
—	Vc	22.8		V- ic.
Yttrium	Y			Yttr.
Zinc	Zn	32.75	32.5	Zinc.
Zirconium	Zr	22.	33.6	Zirc.

COMPOUND RADICALS.

Compound radicals are of several kinds, such as—

- (1) Compounds of carbon and hydrogen.
- (2) Compounds of carbon and nitrogen.
- (3) Compounds of nitrogen, phosphorus, arsenic, or antimony, with hydrogen.

The quantity of a compound which constitutes a radical is as much as forms a single volume of gas. When the compound is not gaseous, the radical quantity is as much as is equivalent in saturating capacity to a single volume of hydrogen or of chlorine.

VICE-RADICALS are compounds that contain carbon and hydrogen or nitrogen and hydrogen; but in which some, or all, of the hydrogen has been replaced, atom for atom, by chlorine or any other element, oxygen alone excepted. These vice-radicals form salts in nearly the same manner, but not with quite the same energy, as the normal radicals from which they are derived.

Every GASEOUS Salt measures *two volumes*, which is the measure of its two radicals, whether they are simple or compound. When a gaseous salt contains oxygen, that element adds to the weight but not to the measure of the gas: it increases its specific gravity, but not its volume. Oxygen measures nothing in any gaseous salt whatever.

Though a compound radical that measures one volume in the state of gas, still measures one volume when combined with one or more atoms of oxygen, the oxygen is not to be considered as a constituent part of the radical, but only as an addition to it.

Muriatic acid, HCl, may be taken as the model of a salt. Any basic radical, simple or compound, may replace H, and produce a chloride = MCl, such as chloride of potassium = KCl, or chloride of methyl = CH³.Cl. Any acid radical, simple or compound, may replace Cl, and produce another hydride, such as HBr, HS, or H,C⁶H⁵.

When either or both radicals of a salt are oxidised, the compound is an oxygen salt. It is in all cases impossible to determine whether the oxygen of a salt is combined exclusively with either of the two radicals, or divided, equally or unequally, between them. In framing equations for the purpose of explaining theoretical opinions respecting the constitution or transformations of compounds, we may place the oxygen in that manner which best answers our special intention; but in the construction of formulæ for purposes of classification or nomenclature, the oxygen should, in all cases, be put together at the end of the formulæ.

Since all gaseous salts that contain two radicals form two volumes of gas, whether the radicals are simple or compound, oxidised or not oxidised, it is assumed, that every compound radical, if isolated and brought into the gaseous state, would measure one volume. In justifica-

tion of this assumption, it may be added, that every gaseous compound radical that has yet been isolated measures one volume, and is the equivalent of one volume of hydrogen or of chlorine.

Salts combine with one another, so as to form double, triple, quadruple, and other forms of compound salts.

Radicals, whether simple or compound, are divisible into two classes, namely,—

ACID radicals, or *Electro-Negative* radicals.

BASIC radicals, or *Electro-Positive* radicals.

Among the simple substances, the Metalloids, or Non-metallic elements form Acid radicals, while the Metals generally form Basic radicals, though several of them form Acid radicals. The element Hydrogen holds an intermediate rank. It is a basic radical when in combination with a metalloid. It is an acid radical when in combination with a metal. The presence or absence of Oxygen does not change this relationship. Thus:—

HCl	= Hydrochloric acid	}	Have acid properties depending upon Cl and S.
HSO ²	= Hydrated sulphuric acid		
BaHO	= Hydrate of barytes	}	Have basic properties depending upon Ba and K.
KHO	= Hydrate of potash		

The properties which bear the names of *Acidity* and *Alcalinity* depend upon the presence of Hydrogen, and cannot be manifested in its absence. Blue litmus and Red litmus are not affected in colour by any substance that is free from hydrogen.

One principle on which the Compound radicals may be separated into Basic and Acid will be explained in the section on hydrocarbons. But there is no specific line of demarcation between basic and acid radicals, not even of those which are elementary. What has been stated of the varying power of hydrogen is true of the radicals produced by most other elements. They act as basic radicals under one set of circumstances and as acid radicals under another set. We can, nevertheless, give to the Elements a classification which approximates to correctness, and which, though subject to numerous exceptions and corrections, affords useful general views of the relations which the elementary radicals bear to one another in respect to their principal faculty of combining together to form salts.

CLASSIFICATION OF ELEMENTARY RADICALS.

Class I.

THE ONLY ELEMENT WHICH DOES NOT ACT AS A RADICAL.

1. Oxygen. *Symbol* = O.

Class II.

THE ELEMENT WHICH ACTS AGAINST THE METALS AS AN ACID RADICAL,
AND AGAINST THE METALLOIDS AS A BASIC RADICAL.

2. Hydrogen = H.

Class III.

ELEMENTS WHICH PRODUCE ACID RADICALS.

3. Nitrogen	= N	17. Fluorine	= F
4. Carbon	= C	18. Boron	= B
5. Sulphur	= S	19. Silicon	= Si
6. Selenium	= Se	Chromium :	
Tellurium :		20. The Chromous radical	= Cr
7. The Tellurous radical	= Te	21. The Chromic radical	= Cr
8. The Telluric radical	= Tec	Molybdenum :	
9. Phosphorus	= P	22. The Molybdous radical	= Mo
Arsenic :		23. The Molybdic radical	= Moc
10. The Arsenous radical	= As	Vanadium :	
11. The Arsenic radical	= Asc	24. The Vanadous radical	= V
Antimony :		25. The Vanadic radical	= Vc
12. The Stibous radical	= Sb	26. Tungstenum	= W
13. The Stibic radical	= Sbc	27. Titanium	= Ti
14. Chlorine	= Cl	28. Tantalum	= Ta
15. Bromine	= Br	29. Pelopium	= Pe
16. Iodine	= I	30. Niobium	= Nb

Class IV.

ELEMENTS WHICH PRODUCE BASIC RADICALS.

Section I.—Metallic Radicals of the Alkalies.

31. Potassium	= K	33. Lithium	= L
32. Sodium	= Na	34. [Ammonium]	= Am

Section II.—Metallic Radicals of the Alkaline Earths.

35. Barium	= Ba	38. Magnesium	= Mg
36. Strontium	= Sr	39. Lantanium	= La
37. Calcium	= Ca		

Section III.—Metallic Radicals of the Non-Alkaline Earths.

Aluminum :		46. Terbium	= Tb
40. The Aluminous radical	= Al	47. Erbium	= E
41. The Aluminic radical	= Alc	Cerium :	
42. Glucinum	= G	48. The Cerous radical	= Ce
43. Yttrium	= Y	49. The Ceric radical	= Cec
44. Zirconium	= Zr	50. Didymium	= D
45. Thorium	= Th		

Section IV.—*Metals proper.*

Iron :		Mercury :	
51.	The Ferrous radical = Fe	70.	The Mercurous radical = Hg
52.	The Ferric radical = Fec	71.	The Mercuric radical = Hgc
Manganese :		72.	Silver = Ag
53.	The Manganous radical = Mn	Gold :	
54.	The Manganic radical = Mnc	73.	The Aurous radical = Au
Nickel :		74.	The Auric radical = Auc
55.	The Niccolous radical = Ni	Platinum :	
56.	The Niccolic radical = Nic	75.	The Platinous radical = Pt
Cobalt :		76.	The Platinic radical = Ptc
57.	The Cobaltous radical = Co	77.	Ilmenium : = Il
58.	The Cobaltic radical = Coc	Iridium :	
Copper :		78.	The Iridous radical = Ir
59.	The Cuprous radical = Cu	79.	The Iridic radical = Irc
60.	The Cupric radical = Cuc	Osmium :	
Uranium :		80.	The Osmous radical = Os
61.	The Urous radical = U	81.	The Osmic radical = Osc
62.	The Uric radical = Uc	Palladium :	
Bismuth :		82.	The Pallous radical = Pd
63.	The Bismous radical = Bi	83.	The Pallic radical = Pdc
64.	The Bismic radical = Bic	Rhodium :	
Tin :		84.	The Rhodous radical = Rh
65.	The Stannous radical = Sn	85.	The Rhodic radical = Rhc
66.	The Stannic radical = Snc	Ruthenium :	
67.	Lead = Pb	86.	The Ruthous radical = Ru
68.	Zinc = Zn	87.	The Ruthic radical = Ruc
69.	Cadmium = Cd		

Those who have been accustomed to consider the chemical equivalent of an element to be *one indivisible atom* may feel averse to admit that that time-honoured doctrine is fallacious. Yet, that it is fallacious is clearly the fact. There is no evidence to prove the existence of indivisible atoms, and consequently none to prove that each element has only one atom or combining quantity; while the existing groups of chemical phenomena demand for their explanation the assumption of the double equivalents, or double radicals, which are enumerated in this Table.

To give a general notion of the nature of these double radicals, I may explain that the salts which are commonly called *protosalts*, or salts of the assumed protoxides of the metals, contain the larger of the two equivalents, or that which I call the *BASYLOUS atom*, while the salts which are commonly called the *sesquisalts*, or *persalts*, being the salts produced by the so-called sesquioxides or peroxides of the metals, are those which contain the smaller of the two equivalents, or that which I call the *BASYLIC atom*.

The basylous and basylic atom of the same element are each equivalent in chemical force to the other and to a single volume of hydrogen. Each radical can make a salt with the same quantity of any acid radical, simple or compound, organic or inorganic, oxidised or not oxidised. They have, under all circumstances, that perfect chemical equivalency to one another which distinguishes the atoms of two different metals, and as their compounds all differ essentially from one another as well in chemical properties as in weight, the two radicals might be taken for two different metals were it not for the peculiarity that they are readily convertible one into the other, under circumstances that are perfectly intelligible and perfectly under our control. Thus—

1. When *BASIC Radicals* in excess are exposed to the action of a limited quantity of *ACID Radicals*, the *BASIC Radicals* assume the *BASYLOUS* state.
2. When *BASIC Radicals* in limited quantity are exposed to the action of an excess of *ACID Radicals*, the *BASIC Radicals* assume the *BASYLIC* state.

These laws are the exponents of experimental facts, and they present striking evidence in favour of the electrical theory of binary combination. One basic radical can combine with only one acid radical. There is no such thing as combination in multiple proportions. That doctrine is fallacious and deceptive. The basic metals produce their small or their large atoms according to the requirements of the metalloids or acid radicals with which they are at any time placed in action. The physical or metaphysical question respecting the constitution of atoms has nothing to do with this consideration. I am speaking of acting chemical quantities, such as we have actually to work with in our laboratories. I find there that a metal can and often does give us two different chemical combining quantities, each possessing the powers and properties of a perfect chemical atom. If this is true, and if it disagrees with the Atomic Theory, we must next inquire whether the Atomic Theory is true. But without prejudging that question, this much may be safely assumed, that, whatever may prove to be the constitution of matter, whatever may be the physical nature of atoms, all the substances which we call elements act chemically in quantities which we call equivalents, whilst several elements produce two such chemical equivalents, different from one another in weight and in the properties of their salts, but alike in chemical force or saturating capacity, exercising, therefore, the functions of two different radicals, and requiring to be so esteemed.

The radical theory modifies in a peculiar degree the chemical character which is usually ascribed to oxygen. Hitherto, chemists have been accustomed to consider oxygen as a centre round which all other elements gyrate—the sun of the chemical planetary system. It exercised the most extensive and most antagonistic functions. It was essential to the constitution of a Base. It was essential to

the constitution of an Acid. The Base and the Acid combined to form a salt, in which the oxygen must have played two opposite characters, or if, in the salt, the oxygen played but one part, then the base and the acid must have ceased to have two separate existences. But the plain fact is, that there does not exist the slightest evidence to prove the truth of the assumption that salts contain acids and bases, and that in these acids and bases the oxygen is divided between the metalloids and metals in certain unequal ratios—such as, 2 to 1, 3 to 1, 5 to 1, 7 to 1, &c. All these assumed intercombinations of atoms is only a play of the fancy—mere guess-work, which ought not to be considered as sober scientific knowledge. The salts contain metals and metalloids, or compound radicals which are equivalent to them, atom for atom. There is no doubt of that. They also sometimes contain oxygen, though we do not know in what condition. The radical theory proves to us, that the substantive elements of a salt, whether it is acid, alkaline, or neutral, are the two radicals which it contains. Without two radicals there can be no salt. Without oxygen we can have many salts. Any two radicals, simple or compound, can form a salt, with no oxygen, with one atom, or two, or three, or four atoms of oxygen. The equivalency of the radicals is not affected by the presence or absence of oxygen. Those salts which have no oxygen are as perfect in their characters as those which have much oxygen. Those salts which are gaseous have no increase in volume from the acquisition of oxygen. A volume of hydrogen in combination (not forming part of a radical) measures a volume; so does a volume of chlorine. One, two, or three volumes of oxygen in combination with two radicals, measure nothing beyond the measure proper to the two radicals. Oxygen, therefore, is not a radical, or *salt-former*, in the sense in which hydrogen, chlorine, the metals, and the hydrocarbons are radicals. A volume of it is not the equivalent, either of one volume, or of two volumes, of hydrogen or of chlorine. Its action is peculiar to itself, and not a property which it holds in common with other elements. In forming our notions of salts, and in framing our plans for their classification, we should consequently do so without regard to the presence or absence of oxygen. For that reason, we say that a compound of two radicals is a salt, whether the radicals are oxidised or not. And by enlarging our conception of the word “radical,” so that it signifies either elements or compound radicals, we are provided with a theory of the salts that applies equally to inorganic and to organic chemistry.

Oxygen is not only unnecessary to the existence of a salt, but it is not even the *acid-former* in the sense that many chemists so consider it. Even among inorganic compounds, oxygen, as was many years ago pointed out by Davy, is not the cause of acidity. Chloride of potassium = KCl is a neutral salt, and when three atoms of oxygen are added, producing chlorate of potash = KClO_3 , the salt is still neutral. The hydrate of chloric acid = HClO^3 is an acid. Remove all the oxygen,

leaving hydrochloric acid = HCl, and the compound is still acid. So, among compound organic radicals, the presence or the quantity of oxygen is not the cause of acidity. An acid requires the presence of an acid radical. An acid radical can sometimes be produced by the action of oxygen on non-acid compounds, but even then the acid is seldom the result of the mere addition of oxygen. Other circumstances operate to this end, and, among these, one of the most important, as I shall show in treating of the hydrocarbons, is the *right apportionment of their hydrogen to their carbon*.

THE CONSTRUCTION OF FORMULÆ.

It should be adopted by chemists as an inflexible rule, to use no letters, figures, or other symbols in writing formulæ, but such as can be printed by the types commonly kept in every printing-office. There should be no crossed letters, and no brackets, or copulæ that require an unusual description of type.

The theory of the constitution of the salts which I am now advocating, namely, that every salt consists of two radicals, simple or compound, oxidised or not oxidised, is one that leads to a simple and regular method of writing formulæ. For example, the benzoate of methyl contains the two radicals benzyl and methyl, combined with two atoms of oxygen. We may consider the two radicals to be each combined with one atom of oxygen, and may represent the salt as a combination of the two oxidised radicals $\text{CH}^3\text{O} + \text{C}^7\text{H}^5\text{O}$; but, considering that, in cases of double decomposition, the division of the components of this salt seems to take place, not where the sign + is placed, in the above formula, but in the following manner: $\text{CH}^3 + \text{O}, \text{C}^7\text{H}^5\text{O}$, so that all the oxygen appears to go with the acid radical, it is expedient in this and all cases of oxidised salts, to put the whole of the oxygen together at the end of the formula, thus: $\text{CH}^3, \text{C}^7\text{H}^5\text{O}^2$. We have here distinctly placed before us the two acting substances of the salt; first, the basic radical, and next, the acid radical, while the subjunctive oxygen is thrown to the end. It is not to be understood, from this proposal, that I wish it to be considered an ascertained fact, that in every salt the oxygen is wholly combined with the acid radical. It may be so, but we have no proof that it is so, and I do not pretend to decide this difficult question. The proposal to indicate all the oxygen in one sum is simply to give regularity to the formula, and, as I shall show presently, to facilitate the construction of a systematic nomenclature.

When there are several radicals, as in all cases of compound salts, they are to be written in a straight line, separating them from one another by a comma, and placing a semicolon before the acid radical. Thus—

Na, C^5H^9 ; S^2O^3 . . . Sulphite of soda and valeryl.
 Na, NH^4 , H; PO^4 . . . Phosphate of soda and ammonia.

This method of writing formulæ is equally applicable to the salts of inorganic radicals. Thus, the sulphates are to be written MSO^2 , the oxalates MCO^2 , the carbonates M_2CO_3 , the nitrates MNO_3 , &c.

It does not appear to me to be advisable to adopt abridged symbols for the hydrocarbon radicals, such as Et for ethyl, A for acetic acid, and the like. The full symbol for the radicals of such compounds is only C^mH^n ; so that little is gained by abridgment, while we lose the important advantage presented to the eye by the factors which belong to the full symbols. One need not object to Cy instead of CN, because it does not tax the memory; but the symbols of the basic and acid compound radicals containing H and C should never be abridged.

SYSTEMATIC NOMENCLATURE.

I have defined a salt to be a compound of two radicals, simple or compound, with or without oxygen. I proceed to show in what manner such compounds can be provided with simple and accurate names.

The name of each salt is to consist of two words, the first of which is to designate the basic radical, and the second to designate the acid radical, and to specify the number of atoms of oxygen, if any is present. The names of simple radicals are, of course, to be the names of elements or some convenient abridgments of them, such as I have proposed for consideration in the last column of the Table at page 123. The names of compound radicals of the hydrocarbon series, may be such words as ethyl, acetyl, and benzyl. Of these there must be one for every hydrocarbon known to exist. In the selection of such names, it is advisable to avoid those which indicate numbers: trityl, octyl, and the like.

The atoms of oxygen are to be indicated by a change in the termination of the name of the acid radical of each salt. The numerals which I propose for this purpose are as follow:—

1 ate.	4 ote.	6 aze.	9 oze.
2 ete.	5 ute.	7 eze.	10 uze.
3 ite.		8 ize.	

This system is sufficient for all compounds that consist of two radicals in combination with oxygen; but in order to provide names for compounds that contain more than two radicals, and for those which contain no oxygen, it is necessary to provide terminal numerals which are to be used for radicals only, and are not to indicate oxygen. I propose the following:—

1 a, an, or ane.		6 ad or ade.
2 e, en, ene.		7 ed ede.
3 i, in, ine.		8 id ide.
4 o, on, one.		9 od ode.
5 u, un, une.		10 ud ude.

Such of the elements as give two radicals already possess characteristic terminations—*ous* and *ic*, which must not be displaced by the numerals. See the Table of Elements at page 123. I propose to insert the numerals between the root of each name and its terminal *ous* or *ic*. Thus :—

Ferranous = Ferr-an-ous = one ferrous atom.
 Ferrinic = Ferr-in-ic = three ferric atoms.

But when only one atom is spoken of, the numeral may in all ordinary cases be omitted, and, without causing any doubt to arise, we may say—

Ferrous . . for one ferrous atom.
 Ferric . . for one ferric atom.

In some compound words it may be proper, for the sake of brevity, to omit the terminal *ous*, but the same liberty must never be taken with the terminal *ic*, otherwise the distinction between the two kinds of radicals would be lost.

When speaking in a general sense of the non-oxidised salts, I propose to use the termination *ane*, as in the following examples :—

<i>Present Names.</i>	<i>Proposed Names.</i>
Fluorides or hydrofluates	= Fluoranes.
Chlorides or Hydrochlorates	= Chloranes.
Iodides or hydriodates	= Iodanes.
Bromides or hydrobromates	= Bromananes.
Sulphides or hydrosulphates	= Sulphanes.
Phosphides or phosphurets	= Phosphanes.
Carbides or carburets	= Carbanes.

But in speaking of individual compounds of this kind, I prefer the use of the termination *a*. Thus :—

Muriatic acid = HCl	= Hydra chlora.
Chloride of sodium = NaCl	= Natra chlora.
Sulphuret of potassium = KS	= Potassa sulpha.
Fluoride of Calcium = CaF	= Calca fluora.

The following examples show the relation of the names required for oxidised salts to those required for non-oxidised salts :—

Hydrochloric acid	= HCl	= Hydra chlora.
Hydrated chloric acid	= HClO ³	= Hydra chlorite.
Chloride of barium	= BaCl	= Baryta chlora.
Chlorate of barytes	= BaClO ³	= Baryta chlorite.
Sulphuretted hydrogen	= HS	= Hydra sulpha.
Hydrated Sulphuric acid	= HSO ²	= Hydra sulphete.

Sulphuret of iron	= FeS	= Ferrous sulpha.
Protosulphate of iron	= FeSO ^o	= Ferrous sulphete.
Hydrocyanic acid	= HCy	= Hydra cyana.
Hydrated cyanic acid	= HCyO	= Hydra cyanate.
Cyanide of Potassium	= KCy	= Potassa cyana.
Cyanate of potash	= KCyO	= Potassa cyanate.

When a hydrated acid becomes a salt, the basic hydrogen is replaced by a basic radical, and in the nomenclature, a corresponding change takes place, the abridged word *hydra*, signifying hydrogen, being replaced by the *abridged name* of the basic radical (see page 123), while the name which indicates the acid radical of the salt, and which, at the same time, enumerates the oxygen, remains unchanged. Thus, substituting Barytes for Hydrogen,—

Hydra chlora	= HCl,	becomes Baryta Chlora	= BaCl.
Hydra chlorite	= HClO ^o ,	„ Baryta Chlorite	= BaClO ^o .

In the designation of compound salts, I propose to abridge certain phrases, as follow :—

<i>Combined with one atom of</i>	by the word	<i>cum.</i>
<i>Combined with two atoms of</i>	„	<i>bis.</i>
<i>Combined with three atoms of</i>	„	<i>tris.</i>

To denote WATER OF CRYSTALLIZATION, I propose to abridge the term *aqua* to AQU, and to add the terminals of the oxygen series. Thus :—

Aquate	will signify	one atom of water.
Aquete	„	two atoms „
Aquite	„	three atoms „
Aqueze	„	seven atoms „
Aquabete	„	twelve atoms „

A more complete explanation of this new nomenclature, with examples of its application to compounds of every description, will be found in my work on the Radical Theory. It would be out of place in this elementary treatise to press the subject unduly upon the reader's attention. I content myself with giving this short general explanation, to be followed in the body of the work by some examples. It is not likely that, in the present disorganised condition of theoretical chemistry, *any* systematic nomenclature will be generally adopted; but it may be useful to the student to know what can be done in that direction, with a view to changes that must necessarily take place not long hereafter. When the schools come generally to admit the non-existence of acids and bases, they will renounce the use of a nomenclature which implies the profession of a faith that will then be out of fashion.

THE CONSTITUTION OF GASES AND VAPOURS.

Among the methods that have been suggested for determining how much of an element constitutes a combining proportion, the one which is apparently least liable to error is that which considers the specific gravities of elementary gases to be the expression of their combining proportions. Upon that idea,

the atomic weight of oxygen is	=	16
that of hydrogen is	=	1
„ chlorine is	=	35.5
„ nitrogen is	=	14

It was pointed out by Gay-Lussac in the year 1809, that the combining weights of elements which produced gases, actually had this relation to the weights of single volumes of gases, so that combination actually took place either between even volumes of gases or between simple multiples of even volumes. It is consequently made a fundamental principle of the Radical Theory, that a gaseous element has an atomic measure of one volume, which means that its specific gravity is equal to its chemical equivalent, or its atomic weight, or its combining proportion.

A second axiom of the Radical Theory is, that every compound radical which acts as the equivalent of an atom of hydrogen or of chlorine, measures, in the gaseous state, like its equivalents, one volume. In all cases, where these compound radicals have been isolated and weighed, they have been found to agree with this axiom. Thus one volume has been found by experiment to be the atomic measure of the following organic compounds:—

C H Formyl.	C ² H ⁵ Ethyl.	C ⁵ H ¹¹ Amyl.
C H ² Vinyl.	C ³ H ⁵ Allyl.	C ⁶ H ¹³ Hexyl.
C H ³ Methyl.	C ⁴ H ⁹ Butyl.	AsC ² H ⁶ Cacodyl.
	CN Cyanogen.	

In the third place, compounds of two radicals, whether the radicals are simple or compound, oxidised or not oxidised, are assumed to form two volumes of vapour, because their two radicals *combine without condensation*. The groups of compounds presented in the Table of gases and vapours, show many proofs of the correctness of this assumption, among the hydrocarbons, to which I may add the following compounds, each of which forms two volumes of gas:—

HHO	Water.	HCy	Cyanhydric acid.
HCl	Chlorhydric acid.	CyBr	Bromide of cyanogen.
HBr	Bromhydric acid.	CyCl	Chloride of cyanogen.
HI	Iodhydric acid.	C ⁶ H ⁵ Cy	Cyanide of phenyl.

So far the atomic measures, both of elements and compounds, are all regular. There is one volume for an atom of a radical, and two volumes for an atom of a compound of two radicals. But the above compounds amount to less than half the number of known gases and vapours, and we have now to consider the compounds whose measures are apparently irregular.

The fact has already been pointed out, that oxygen, which, in the free state, measures one volume, measures nothing when in combination with two radicals, but serves only to increase the *weight* of the compound into which it enters. I cannot account for that fact, and will not dwell upon it, but proceed to the consideration of the properties of other elements, a summary of which is presented in the Table printed on pages 138 and 139. In this Table, the gasifying powers of those elements which become constituents of volatile compounds, are discriminated with precision. Thus, the Table shows, with regard to each radical,

- 1) Its atomic weight, which, in the cases of O, H, Cl, Br, I, N, and Hgc, is the weight of one volume of its gas or vapour.
- 2) Its atomic measure when isolated.
- 3) Its atomic measure when it exists in the state of a salt, that is to say, when it forms part of a compound in which two radicals, (exclusive of oxygen) are present.
- 4) The condensing power of one atom of the radical on each volume of every radical with which it is in combination.

The last two particulars have been hitherto overlooked by chemists.

I have added to the list of gasifying elements a short list of gasifying compounds, and a Table of Exceptions which exist among inorganic gases. In my larger work I have described a few irregularities among organic compounds.

It is not a little remarkable that those gases which are most conformable to general laws, are the gases which are produced by organic compounds—gases which up to a recent period were considered to be most irregular in their constitution and most incapable of subjection to general laws; while those gases which are actually most irregular and most incapable of reduction to the laws which are applicable to the great body of gases and vapours, are the inorganic gases which have hitherto been held by chemists to be most orderly and regular.

Method commonly employed by Chemists to find the specific gravity of Compound Gases.

The usual method of calculating the specific gravities of compound gases is described by Sir Robert Kane as follows (Elements of Chemistry (1849), page 290). "The simplicity shown to exist between the volumes of the constituent and compound vapours, enables us very often to calculate beforehand what the specific gravity of a vapour should be, and thus to ascertain how closely the numbers found experimentally approach to absolute correctness. . . . The general rule is to multiply the specific gravities of the simple gases or vapours respectively, by the volumes in which they combine, to add these products together, and then to divide the sum by the number of volumes of the compound gas produced."

To be able to put this rule into practice, we must know the specific gravities of the gases, as commonly expressed in terms referring to the density of air as unity, and we must also know the assumed combining volume of each elementary gas, and the measure of the compound gas.

Advantages of the method suggested by the Radical Theory.

On the radical theory, we require only the formula of the compound gas, and the data presented in the following Table, to be able to calculate not only the specific gravity of the compound gas, but its atomic measure also, which is a quantity that the ordinary rule requires to be given as one of the data from which to calculate the specific gravity.

Examples:—

$\text{HHO} = \text{Water}$. Atomic weight $1 + 1 + 16 = 18$. The two atoms of hydrogen measure two volumes, and the oxygen measures nothing. Hence the atomic measure is two volumes, and the specific gravity is $18 \div 2 = 9$. To find the specific gravity in terms referring to air taken at 1.00 , the specific gravity 9 must be divided by 14.47 , which represents the specific gravity of atmospheric air when unity is hydrogen ($\text{H} = 1$).

$\text{SnCl} = \text{Chloride of Tin}$. Atomic weight $29.5 + 35.5 = 65$. The atom of tin measures nothing in combination, and reduces the measure of the chlorine from one volume to half a volume. Hence the atomic measure is half a volume, and as it requires two atoms of the compound to complete one volume, the specific gravity is $65 \times 2 = 130$.

$\text{C}^2\text{H}^5\text{S} + \text{HS}$. *Mercaptan*. The hydrosulphate of sulphide of ethyl. Atomic weight, $29 + 16 + 1 + 16 = 62$. The atom of ethyl, like all the compound organic radicals, measures one volume in combination. The atom of hydrogen measures one volume. The two atoms of sulphur measure nothing. No condensing power is present. The total measure is consequently two volumes, and the specific gravity is $62 \div 2 = 31$.

[Continued at page 139.]

Radicals which produce Gases.	Atomic Weight.	Atomic Measure when Isolated.	Atomic Measure in Salts.	Condensing Power of one Atom of the Radical on each Volume of every Radical with which it combines.
ELEMENTS.				
Oxygen . . . O	16	I	O	O.
Carbon . . . C	12		O	O.
Sulphur . . . S	16	$\frac{1}{8}$	O	O.
Selenium . . . Se	40		O	O.
Tellurium . . . Te	64		O	O.
Zinc . . . Zn	32.75		O	O.
Chromium . . . Cr	27		O	O.
Hydrogen . . . H	1	I	I	O.
Chlorine . . . Cl	35.5	I	I	O.
Bromine . . . Br	80	I	I	O.
Iodine . . . I	127	I	I	O.
Fluorine . . . F	19		I	O.
Nitrogen . . . N	14	I	I	O.
Mercury . . . Hgc	100	I	O	O.
— . . . Hg	200		I	O.
Phosphorus . . . P	31	$\frac{1}{2}$	$\frac{1}{2}$	I volume to $\frac{1}{2}$ volume.
Arsenic . . . Asc	25	$\frac{1}{8}$	$\frac{1}{6}$	I volume to $\frac{1}{2}$ volume.
Antimony . . . Sbc	40		$\frac{1}{6}$	I volume to $\frac{1}{2}$ volume.
Bismuth . . . Bic	70		$\frac{1}{6}$	I volume to $\frac{1}{2}$ volume.
Boron . . . B	3.5		$\frac{1}{6}$	I volume to $\frac{1}{2}$ volume.
Silicon . . . Si	7.		O	I volume to $\frac{1}{2}$ volume.
Titanium . . . Ti	12		O	I volume to $\frac{1}{2}$ volume.
Tin Snc	29.5		O	I volume to $\frac{1}{2}$ volume.
COMPOUNDS.				
Radicals . . . C ⁿ H ²ⁿ⁺¹		I	I	O.
Radicals . . . C ⁿ H ²ⁿ⁻¹		I	I	O.
Radicals . . . C ^m H ^{2m}			O	O.
Vinyl . . . CH ²	14	I	O	O.
Succinyl. . . C ² H ²	26		O	O.
Salicyl . . . C ⁷ H ⁴	88		O	O.
Amidogen . . NH ²	16		I	O.
Cyanogen Cy = CN	26	I	I	O.
Cyanyl Cyl = CN	26		$\frac{1}{6}$	I volume to $\frac{1}{2}$ volume.

Radicals which produce Gases.	Atomic Weight.	Atomic Measure when Isolated.	Atomic Measure in Salts.	Condensing Power of one Atom of the Radical on each Volume of every Radical with which it combines.
EXCEPTIONS AMONG INORGANIC GASES.				
Carbonic Oxide . CO	28	2	0	0.
Carbonic Acid . CO ²	44	2	0	0.
Deutoxide of Nitrogen . . } NO	30	2	1	0.
Peroxide of Nitrogen . . } NO ²	46	2	1	0.
Sulphurous Acid SO	32	1	0	0.
Selenious Acid . SeO	56	1	0	0.
Sulphuric Acid, } SSO ³	80	2	0	0.
Anhydrous .				
— Hydrated . HSO ²	49	2	1	0.
Chloric Oxide . ClO ²	67.5	2	1	0.
Xanthyl . . . CS ⁴	76	2	0	0.

H, C²H⁵O. *Alcohol*. Atomic weight, 1 + 29 + 16 = 46. The hydrogen and the ethyl measure in combination one volume each, and the oxygen measures nothing. Hence the atomic measure of alcohol is two volumes, and its specific gravity is 46 ÷ 2 = 23.

It is unnecessary to quote other examples, because the Table of Gases, presents them in abundance.

In contrast with the simplicity of the mode of calculation afforded by the radical theory, I will quote Poggendorff's account (*Handwörterbuch der Chemie*, Band II, pp. 478, 488) of the gaseous constitution of the last two compounds, the aspect of which shows the difficulties and uncertainties of the ordinary mode of reckoning:—

	Component Volumes in 1 Vol. of Compound.	Condensation.	Atoms in 1 Vol.	Specific Gravity.
Mercaptan	$\left\{ \begin{array}{l} \text{CH}_3\text{S}\frac{1}{6} \\ \frac{1}{2}\text{C}_2\text{H}_5\text{S}\frac{1}{6} + \frac{1}{2}\text{HS}\frac{1}{6} \\ \text{CH}_2 + \text{HS}\frac{1}{6} \end{array} \right.$	25 : 6	$\frac{1}{2}$	2,15822
		1 : 1		
		2 : 1		
Alcohol	$\left\{ \begin{array}{l} \text{CH}_3\text{O}\frac{1}{2} \\ \frac{1}{2}\text{C}_2\text{H}_5\text{O}\frac{1}{2} + \frac{1}{2}\text{HO}\frac{1}{2} \\ \text{CH}_2 + \text{HO}\frac{1}{2} \end{array} \right.$	9 : 2	$\frac{1}{2}$	1,60049
		1 : 1		
		2 : 1		

One of the marvels of modern chemistry is the persistence of its professors in the practice of comparing the specific gravities of gases with that of common air taken as unity. To be consistent, they should adopt the additional absurdity of taking the composition of common air as the standard of the atomic weights. Just look at these two examples of specific gravities! The atomic weight of mercaptan is 62, and its specific gravity is 31; the atomic weight of alcohol is 46, and its specific gravity is 23; but these numbers are too simple to have the proper look of philosophical profundity, so The Authorities of our science fix the specific gravity of mercaptan at 2.15822, and of alcohol at 1.60049—beautiful numbers! which contain the quantity of Egyptian darkness necessary to render them grand and mysterious, and which confer upon the scientific world the remarkable advantages that always flow from the statement of simple facts in terms which no memory can retain.

TABLE showing the COMPOSITION, SPECIFIC GRAVITIES, ATOMIC WEIGHTS and ATOMIC MEASURES of GASES and VAPOURS.

The compounds are arranged in this Table alphabetically, according to the names in common use. The following particulars are given of each:—

1. Its formula according to the system described in this essay.
2. The observed specific gravity of the gas, stated against that of atmospheric air taken as unity.
3. The atomic weight of each compound on the hydrogen scale.
4. The specific gravity on the same scale, H = 1.
5. Under the head of atomic measure I have given the number of volumes which contain an atom, or equivalent, of each gas.

The original Table of gases, of which the present is an abstract, contains also the following particulars:—

6. The names of the chemists by whom the observed specific gravity of each gas was determined.
7. The observed specific gravity stated against the specific gravity of hydrogen gas taken as unity; showing the close approximation of the observed and calculated densities.

These particulars will be found in my work on the Radical Theory, page 50. They present the *evidence* upon which the present Table is founded; but in this place, for the sake of brevity, I take the results only and omit the evidence. Yet this Table affords the means of readily comparing the evidence with the theoretical conclusions. The relations between the densities of hydrogen gas and atmospheric air are as follow:—

Air	14.47	1.00
Hydrogen	1.00	0.0693

Consequently, the specific gravities on the hydrogen scale, when divided

by 14.47 give those on the air scale, and conversely those on the air scale, when multiplied by 14.47, give those on the hydrogen scale.

In connection with the proposal to mark the specific gravities of gases in numbers relating to their atomic weights, I take this opportunity of suggesting, that the vessels in which chemists are accustomed to measure gases, might be graduated in such a manner as to indicate the weight of the gases. This can be effected by adopting, as a standard gas measure, a vessel that contains one grain of hydrogen gas, the volume of which at 60° F., and 30 ins. Bar., is 46.7 cubic inches. This vessel may be divided into 100 spaces, each of which will contain $\frac{1}{100}$ grain of hydrogen gas. A vessel, one-tenth of that size, = $4\frac{2}{3}$ cubic inches, divided into 100, would have divisions, each = $\frac{1}{1000}$ grain of hydrogen gas. The weight of any gas measured in these vessels would be found by multiplying the measure of the gas by its specific gravity, according to the theoretical number given in the following Table. Thus, 80 measures of dry nitrogen gas collected in the small tube, at 30 ins. Bar. and 60° F., would weigh $0.080 \times 14 = 1.12$ grain. Of course, corrections upon the measure of a gas, collected over water at another temperature, and under a different pressure, would have to be made as usual. Vessels thus graduated would be useful for class experiments, as well as for analytical purposes. To give one example,—A receiver for showing the combustion of phosphorus in oxygen gas, may be known to contain 10 grains of hydrogen gas. The question is, how much chlorate of potash will afford oxygen gas sufficient to fill it? 10 grains of H = 10 atoms of H = 10 atoms of O. The formula of chlorate of potash being KClO_3 , the quantity required is $3\frac{1}{3}$ atoms, and taking the atom of this salt at 122.5 grains, we find that $122\frac{1}{3} \times 3\frac{1}{3} = 408\frac{1}{3}$ grains of the chlorate of potash will give the requisite quantity of oxygen gas.

NAME OF GAS.	Composition.	Atomic Weight.	Atomic Measure.	Specific Gravity H = 1.	Observed Sp. Grav. Air = 1.
Atmospheric Air . . .				14.47	1.00
Acetic Acid, Hydrate . . .	$\text{H}, \text{C}^2\text{H}^3\text{O}^2$. . .	60.	2	30.	2.08
— Anhydrous	$\text{C}^2\text{H}^3, \text{C}^2\text{H}^3\text{O}^3$. . .	102.	2	51.	3.47
Acetone	$\text{CH}^3, \text{C}^2\text{H}^3\text{O}$	58.	2	29.	2.022
Acetylamine	$\text{NH}, \text{C}^2\text{H}^3; \text{H}$	43.	2	21.5	1.522
Acetyl, Bromide	$\text{C}^2\text{H}^3, \text{Br}$	107.	2	53.5	3.691
— Chloride	$\text{C}^2\text{H}^3, \text{Cl}$	62.5	2	31.25	2.116
— Iodide	$\text{C}^2\text{H}^3, \text{I}$	154.	2	77.	4.78
— Oxychloride	$\text{C}^2\text{H}^3, \text{ClO}$	78.5	2	39.25	2.87
— Hydrate (Aldehyd)	$\text{H}, \text{C}^2\text{H}^3\text{O}$	44.	2	22.	1.532

NAME OF GAS.	Composition.	Atomic Weight.	Atomic Measure.	Specific Gravity H = 1.	Observed Sp. Grav. Air = 1.
Allyl	C^3H^5	41.	1	41.	2.92
Acrolein	H, C^3H^3O	56.	2	28.	1.897
Allyl, Sulphocyanide	$C^3H^5, Cy; S^2$	99.	2	49.5	3.4
Ammonia	$NH^3 = H, NH^2$	17.	2	8.5	0.597
— Carbamate	$NH^4, NH^2; CO^2?$	78.	6	13.	0.899
— Hydrochlorate	$H, NH^2 + HCl$	53.5	4	13.375	0.89
— Hydrocyanate	$H, NH^2 + HCy$	44.	4	11.	0.802
— Hydrosulphate, Acid	$H, NH^2 + (HS)^2$	51.	4	12.75	0.901
— — Neutral	$H, NH^2 + HS$	34.	3	11.33	0.785
— Hydrotellurate	$H, NH^2 + HTe$	82.	4	20.5	1.32
Amyl	C^5H^{11}	71.	1	71.	4.899
— Hydride	H, C^5H^{11}	72.	2	36.	2.483
— Alcohol	$H, C^5H^{11}O$	88.	2	44.	3.147
— Borate	C^5H^{11}, BO	90.5	$\frac{4}{3}$	135.75	10.55
— Chloride	C^5H^{11}, Cl	106.5	2	53.25	3.8
— Cyanide	C^5H^{11}, Cy	97.	2	48.5	3.335
— Iodide	C^5H^{11}, I	198.	2	99.	6.675
— Acetate	$C^5H^{11}, C^2H^3O^2$	130.	2	65.	4.458
— Nitrite	C^5H^{11}, NO^2	117.	2	58.5	4.03
— Oxalate	C^5H^{11}, CO^2	115.	1	115.	8.4
— Silicate	C^5H^{11}, SiO	94.	$\frac{1}{2}$	188.	11.7
— Sulphide	C^5H^{11}, S	87.	1	87.	6.3
— Hydrosulphide	$C^5H^{11}, H; S^2$	104.	2	52.	3.631
— Valerianate	$C^5H^{11}, C^5H^9O^2$	172.	2	86.	6.17
Anilin	$NH, C^6H^5; H$	93.	2	46.5	3.219
Antimony, Terchloride	$SbcCl$	75.5	$\frac{4}{3}$	113.25	7.8
Antimoniuretted Hy- drogen	$SbcH$	41.	$\frac{4}{3}$	61.5	4.562
Arsenic	As or Asc^3	75.	$\frac{3}{8}$	150.	10.367
—	Asc	25.	$\frac{1}{8}$	150.	10.367
— White Oxide	$Asc, AscO$	66.	$\frac{3}{8}$	198.	13.85
— Chloride	$AscCl$	60.5	$\frac{4}{3}$	90.75	6.30
— Iodide	$AscI$	152.	$\frac{4}{3}$	228.	16.1
Arseniuretted Hydrogen	$AscH$	26.	$\frac{4}{3}$	39.	2.695
Arsentriethyl	$AscC^2H^5$	54.	$\frac{4}{3}$	81.	5.278
Benzoic Acid, Cryst.	$H, C^7H^5O^2$	122.	2	61.	4.27
Benzoile, Chloride	C^7H^5, ClO	140.5	2	70.25	4.987
Bismuth, Chloride	$BicCl$	105.5	$\frac{4}{3}$	158.25	11.16
Boron, Chloride	BCl	39.	$\frac{4}{3}$	58.5	3.942
— Fluoride	BF	22.5	$\frac{4}{3}$	33.75	2.312

NAME OF GAS.	Composition.	Atomic Weight.	Atomic Measure.	Specific Gravity H = 1.	Observed Sp. Grav. Air = 1.
Bromine	Br	80.	1	80.	5.54
Bromhydric Acid	HBr	81.	2	40.5	2.731
Butyl-Amyl	C^4H^9, C^5H^{11}	128.	2	64.	4.465
Butyl-Hexyl	C^4H^9, C^6H^{13}	142.	2	71.	4.917
Butyl	C^4H^9	57.	1	57.	4.053
— Acetate	$C^4H^9, C^2H^3O^2$	116.	2	58.	4.073
— Butylic Alcohol	H, C^4H^9O	74.	2	37.	2.589
— Hydride	H, C^4H^9	58.	2	29.	
— Bromide	C^4H^9, Br	137.	2	68.5	4.72
— Chloride	C^4H^9, Cl	92.5	2	46.25	
— Iodide	C^4H^9, I	184.	2	92.	6.217
— Cyanide (Valeroni- trile)	C^4H^9, CN	83.	2	41.5	2.892
Butylic Mercaptan	$H, C^4H^9; S^2$	90.	2	45.	3.1
Butyrine, or Butylene	H, C^4H^7	56.	2	28.	1.993
Butyral	H, C^4H^7O	72.	2	36.	2.61
Butyric Acid, hydrate	$H, C^4H^7O^2$	88.	2	44.	3.3
— — anhydrous	$C^4H^7, C^4H^7O^3$	158.	2	79.	5.38
Butyrene	C^3H^7, C^4H^7O	114.	2	57.	3.99
Cacodyl	AsC^2H^6	105.	1	105.	7.101
— Oxide (Alkarsin)	$(AsC^2H^6)^2O$	226.	2	113.	7.555
— Chloride	AsC^2H^6, Cl	140.5	2	70.25	4.56
— Cyanide	AsC^2H^6, Cy	131.	2	65.5	4.63
— Sulphide	AsC^2H^6, S	121.	1	121.	7.72
— Oxychloride	$\left\{ \begin{array}{l} 6(AsC^2H^6, Cl) \\ + (AsC^2H^6)^2O \end{array} \right\}$	1069.	14	76.36	5.46
Campholic Acid	$H, C^{10}H^{17}O^2$	170.	2	85.	6.058
Camphor	C^5H^9, C^5H^7O	152.	2	76.	5.317
Caprylene. Octylene	H, C^8H^{15}	112.	2	56.	3.86
Caproic Alcohol	$H, C^6H^{13}O$	102.	2	51.	3.53
Caproic Acid	$H, C^6H^{11}O^2$	116.	2	58.	4.26
Caprylic Alcohol	$H, C^8H^{17}O$	130.	2	65.	4.5
Carbonic Oxide	CO	28.	2	14.	.968
— Acid	CO ²	44.	2	22.	1.529
Carbon, Sulphide (Xanthyl)	CS ⁴	76.	2	38.	2.645
Chlorine	Cl	35.5	1	35.5	2.47
— Chloric Oxide	ClO ²	67.5	2	33.75	2.315
— Hypochlorous Acid	Cl, ClO	87.	2	43.5	2.977
— Chlorous Acid	Cl, ClO ³	119.	3?	39.67	2.646
— Chlorhydric Acid	HCl	36.5	2	18.25	1.247

NAME OF GAS.	Composition.	Atomic Weight.	Atomic Measure.	Specific Gravity H = 1.	Observed Sp. Grav. Air = 1.
CHLORINE COMPOUNDS.					
Chloride of Formyl . . .	CH, Cl . . .	48.5	1	48.5	3.321
Vinyl, containing Cl ¹ ? . . .	C(HCl) . . .				
Protochloride of Carbon . . .	CCl ² . . .	83.	1	83.	5.82
Ethelene, Bibromide . . .	C ² H ⁴ Br ² . . .	188.	2	94.	6.485
Vinyl, Bromide . . .	CH ² Br . . .	94.	1	94.	
Oil of Olefiant Gas . . .	CH ² , Cl . . .	49.5	1	49.5	3.478
Dutch Liquid . . .					
Vinyl, Chloride . . .	CH, Cl ² . . .	84.	1	84.	5.767
Perchloride of Formyl . . .					
Methyl, containing Cl ² ? . . .	C(HCl ²) . . .	118.5	1	118.5	8.157
Sesquichloride of Carbon } Methyl, containing Cl ³ ? }	CCl ³ ? . . .				
Chloroform	H, CCl ³ . . .	119.5	2	59.75	4.199
Chloride of Methyl . . .	CH ³ , Cl . . .	50.5	2	25.25	1.736
Bichloride of Carbon . . .	CCl ³ , Cl . . .	154.	2	77.	5.33
Monochlorinated Me- thylic Ether . . . }	CH ² Cl, CH ² ClO	115.	2	57.5	3.908
Bichlorinated Ditto . . .	CHCl ² , CHCl ² O	184.	2	92.	6.367
Bichloride of Methylene Hydride of Bichlori- nated Methyl . . . }	CH ² Cl, Cl } H, CHCl ² }	85.	2	42.5	3.012
Phosgene Gas.	CCl, ClO . . .	99.	2	49.5	3.46
Chloraldehyd	C ² Cl ³ , ClO . . .	182.	2	91.	6.32
Acetyl, Oxychloride . . .	C ² H ³ , ClO . . .	78.5	2	39.25	2.87
Chloracetic Acid	H, C ² Cl ³ O ² . . .	163.5	2	81.75	5.3
Chloral	H, C ² Cl ³ O . . .	147.5	2	73.75	5.13
Chloral, Hydrate	H ³ , C ² Cl ³ O ² . . .	165.5	4	41.375	2.76
Acetyl, Chloride	C ² H ³ , Cl . . .	62.5	2	31.25	2.116
Ethyl, Chlorocarbonate } Chlorovinic Formiate }	C ² H ⁵ , CClO ² . . .	108.5	2	54.25	3.823
Perchlorovinic Formiate	C ² Cl ⁵ , CClO ² . . .	281.	2	140.5	9.31
Butylene Chloride . . . }	C ² (H ⁴ Cl) . . .	63.5	1	63.5	4.426
Ethyl, containing Cl ¹ ? }					
Monochlorinated Vinic } Ether }	(C ² H ⁴ Cl) ² O . . .	143.	2	71.5	4.93
Ethyl, Chloride	C ² H ⁵ , Cl . . .	64.5	2	32.25	2.219
Monochlorinated Hy- drochloric Ether . . . }	C ² H ⁴ Cl, Cl . . .	99.	2	49.5	3.478

NAME OF GAS.	Composition.	Atomic Weight.	Atomic Measure.	Specific Gravity H = 1.	Observed Sp. Grav. Air = 1.
Bichlorinated Hydrochloric Ether	$C^2H^3Cl^2, Cl$.	133.5	2	66.75	4.53
Terchlorinated Ditto	$C^2H^2Cl^3, Cl$.	168.	2	84.	5.799
Quadrichlorinated Ditto	$C^2H Cl^4, Cl$.	202.5	2	101.25	6.975
Hydrochlorate of Chloro-etherose	H, C^2Cl^5 .	202.5	2	101.25	7.087
Sesquichloride of Carbon Acetyl, Perchloride	$C^2Cl^5, Cl?$. C^2H^3, Cl^3 .	237.	2	118.5	8.157
Hydride of Terchlorinated Ethyl	$H, C^2(H^2Cl^3)?$.	133.5	2	66.75	4.7
Chlorbenzid	$H, C^6H^2Cl^3$.	181.5	2	90.75	6.37
Chloro-Nitrous Gas	$ClNO$.	65.5	2	32.75	
Chromium, Oxychloride	$ClCrO$.	78.5	1	78.5	5.5
Chlorosulphuric Acid	$ClSO$.	67.5	1	67.5	4.665
Sulphite of Perchloride of Carbon	$CCl^3SO + ClSO$	218.	2	109.	7.43
—					
Cumenyl, Hydride	H, C^9H^{11} .	120.	2	60.	3.96
Cumyl, Hydrate	$H, C^{10}H^{11}O$.	148.	2	74.	5.24
Cyanogen	$CN = Cy$.	26.	1	26.	1.806
— Bromide	$CN, Br = CyBr$.	106.	2	53.	3.607
— Chloride	$CN, Cl = CyCl$.	61.5	2	30.75	2.111
— Solid Chloride (of Cyanyl)	$CyCl$.	61.5	$\frac{4}{8}$	92.25	6.35
Cyanhydric Acid	$H, CN = HCy$.	27.	2	13.5	.948
Ethyl	C^2H^5 .	29.	1	29.	2.004
— Ether	C^2H^5, C^2H^5O .	74.	2	37.	2.586
— Alcohol	H, C^2H^5O .	46.	2	23.	1.613
— Acetate	$C^2H^5, C^2H^3O^2$.	88.	2	44.	3.05
— Benzoate	$C^2H^5, C^7H^5O^2$.	150.	2	75.	5.406
— Borate	C^2H^5, BO .	48.5	$\frac{4}{8}$	72.75	5.14
— Bromide	C^2H^5, Br .	109.	2	54.5	3.754
— Butyrate	$C^2H^5, C^4H^7O^2$.	116.	2	58.	4.04
— Caproate	$C^2H^5, C^6H^{11}O^2$.	144.	2	72.	4.965
— Caprylate	$C^2H^5, C^8H^{15}O^2$.	172.	2	86.	6.1
— Carbamate (Urethane)	C^2H^5, NH^2, CO^2	89.	2	44.5	3.14
— — Ethylurethane	$\left\{ \begin{array}{l} C^2H^5, NH, C^2H^5; \\ CO^2, \text{ or } H, C^2H^5, \\ C^2H^5; CNO^2 \end{array} \right\}$	117.	2	58.5	4.071
— Carbonate	$(C^2H^5)^2CO^3$.	118.	2	59.	4.243

NAME OF GAS.	Composition.	Atomic Weight.	Atomic Measure.	Specific Gravity H = 1.	Observed Sp. Grav. Air = 1.
Ethyl Chloride . . .	C^2H^5, Cl . . .	64.5	2	32.25	2.219
— Cinnamate . . .	$C^2H^5, C^9H^7O^2$. . .	176.	2	88.	6.557
— Cuminate . . .	$C^2H^5, C^{10}H^{11}O^2$. . .	192.	2	96.	6.65
— Cyanate . . .	C^2H^5, CyO . . .	71.	2	35.5	2.475
— Cyanurate (Cyany- late) . . .	$C^2H^5, Cy1O$. . .	71.	$\frac{4}{3}$	106.5	7.4
— Formiate . . .	C^2H^5, CHO^2 . . .	74.	2	37.	2.593
— Hydride . . .	H, C^2H^5 . . .	30.	2	15.	1.075
— Iodide . . .	C^2H^5, I . . .	156.	2	78.	5.417
— Laurate . . .	$C^2H^5, C^{12}H^{23}O^2$. . .	228.	2	114.	8.4
— Methyl, Vinylate . . .	$\left\{ \begin{array}{l} C^2H^5, CH^2O \\ CH^3, CH^2O. \end{array} \right\}$. . .	104.	2	52.	3.475
— Nitrite . . .	C^2H^5, NO^2 . . .	75.	2	37.5	2.626
— Oxalate . . .	C^2H^5, CO^2 . . .	73.	1	73.	5.087
— Phosphite (Tribasic)	$(C^2H^5)^3; PO^3$. . .	166.	2	83.	5.8
— Pyromucate . . .	$C^2H^5, C^5H^3O^3$. . .	140.	2	70.	4.859
— Succinate . . .	$C^2H^5, C^2H^2O^2$. . .	87.	1	87.	6.11
— Silicate . . .	C^2H^5, SiO . . .	52.	$\frac{1}{2}$	104.	7.32
— Sulphide . . .	C^2H^5, S . . .	45.	1	45.	3.1
— Bisulphide . . .	C^2H^5, S^2 . . .	61.	1	61.	4.27
— Hydrosulphide (Mercaptan) . . .	$H, C^2H^5; S^2$. . .	62.	2	31.	2.11
— Sulphite . . .	$C^2H^5, C^2H^5; S^2O^3$. . .	138.	2	69.	4.78
— Sulphocyanide . . .	$C^2H^5, Cy; S^2$. . .	87.	2	43.5	3.018
— Valerianate . . .	$C^2H^5, C^5H^9O^2$. . .	130.	2	65.	4.558
— Vinylate, Acetal . . .	C^2H^5, CH^2O . . .	59.	1	59.	4.141
— and Amyl Oxide . . .	$C^2H^5, C^5H^{11}O$. . .	116.	2	58.	4.042
— and Methyl Oxide . . .	CH^3, C^2H^5O . . .	60.	2	30.	2.158
— and Methyl, Oxalate . . .	$CH^3, C^2H^5; C^2O^4$. . .	132.	2	66.	4.677
— -Enanthyl Ether . . .	$C^2H^5, C^7H^{15}O$. . .	144.	2	72.	5.095
— Zinc-Ethyl . . .	ZnC^2H^5 . . .	61.75	1	61.75	4.251
— Stib-Ethyl . . .	$SbcC^2H^5$. . .	69.	$\frac{4}{3}$	103.5	7.438
— Arsen-Ethyl . . .	$AscC^2H^5$. . .	54.	$\frac{4}{3}$	81.	5.278
— -Butyl . . .	C^2H^5, C^4H^9 . . .	86.	2	43.	3.053
— -Amyl . . .	C^2H^5, C^5H^{11} . . .	100.	2	50.	3.522
Ethylamine . . .	$NH, C^2H^5; H$. . .	45.	2	22.5	1.577
Formyl? (Klumene) . . .	CH . . .	13.	1	13.	
Formic Acid, at 322° F.	H, CHO^2 . . .	46.	2	23.	1.61
Hydrogen . . .	H . . .	1.	1	1.	.069
Hexylene (Caproiline) . . .	H, C^6H^{11} . . .	84.	2	42.	2.875
Hexyl . . .	C^6H^{13} . . .	85.	1	85.	5.983

NAME OF GAS.	Composition.	Atomic Weight.	Atomic Measure.	Specific Gravity H = 1.	Observed Sp. Grav. Air = 1.
Iodine	I	127.	1	127.	8.716
Iodohydric Acid	HI	128.	2	64.	4.443
Mercury	Hgc	100.	1	100.	6.976
Mercurous Bromide	HgBr	280.	2	140.	10.14
— Chloride	HgCl	235.5	2	117.75	8.35
Mercuric Bromide	HgcBr	180.	1	180.	12.16
— Chloride	HgcCl	135.5	1	135.5	9.8
— Iodide	HgcI	227.	1	227.	15.9
— Sulphide	HgcS	116.	1½	77.33	5.51
Methyl	CH ³	15.	1	15.	1.075
— Hydride, Marsh Gas	H,CH ³	16.	2	8.	.558
— Methylic Ether	CH ³ ,CH ³ O	46.	2	23.	1.617
— Methylic Alcohol	H,CH ³ O	32.	2	16.	1.12
— Acetate	CH ³ ,C ² H ³ O ²	74.	2	37.	2.563
— Benzoate	CH ³ ,C ⁷ H ⁵ O ²	136.	2	68.	4.717
— Borate (Terbasic)	CH ³ ,BO	34.5	¾	51.75	3.66
— Bromide	CH ³ ,Br	95.	2	47.5	3.155
— Butyrate	CH ³ ,C ⁴ H ⁷ O ²	102.	2	51.	3.52
— Caprylate	CH ³ ,C ⁸ H ¹⁵ O ²	158.	2	79.	5.45
— Chloride	CH ³ ,Cl	50.5	2	25.25	1.736
— Caproate	CH ³ ,C ⁶ H ¹¹ O ²	130.	2	65.	4.623
— Cyanide (Acetonitrile)	CH ³ ,CN	41.	2	20.5	1.45
— Cyanurate (Cyanurate)	CH ³ ,Cy1O	57.	¾	85.5	5.98
— Sulphocyanide	CH ³ ,Cy; S ²	73.	2	36.5	2.57
— Fluoride	CH ³ ,F	34.	2	17.	1.183
— Formiate	CH ³ ,CHO ²	60.	2	30.	2.084
— Hexyl	CH ³ ,C ⁶ H ¹³	100.	2	50.	3.426
— Iodide	CH ³ ,I	142.	2	71.	4.883
— Nitrate	CH ³ ,NO ³	77.	2	38.5	2.653
— Salicylite	CH ³ ,C ⁷ H ⁵ O ²	152.	2	76.	5.42
— Succinate	CH ³ ,C ² H ² O ²	73.	1	73.	5.29
— Sulphide	CH ³ ,S	31.	1	31.	2.115
— Bisulphide	CH ³ ,S ²	47.	1	47.	3.298
— Sulphate	CH ³ ,SO ²	63.	1	63.	4.565
— (Xanthic Ether)	CH ³ ,CH ³ ,CS ⁴ O	122.	2	61.	4.266
— Sulphocarbonate	CH ³ ,CH ³ ,CS ⁴ S ² ?	138.	2	69.	4.652
— Xanthate	CH ³ ,C ² H ⁵ ; CS ⁴ O	136.	2	68.	4.652
— Vinylate	CH ³ ,CH ² O	45.	1	45.	

NAME OF GAS.	Composition.	Atomic Weight.	Atomic Measure.	Specific Gravity H = 1.	Observed Sp. Grav. Air = 1.
Methyl and Amyl Oxide	$\text{CH}_3, \text{C}_5\text{H}_{11}\text{O}$	102.	2	51.	3.73
Methylal	$\text{CH}_3, \text{C}_2\text{H}_5\text{O}^2$	76.	2	38.	2.625
Methylamine	$\text{NH}, \text{CH}_3; \text{H}$	31.	2	15.5	1.08
Nitrotoluine	$\text{C}_7\text{H}_7, \text{NO}^2$	137.	2	68.5	4.95
Naphtha	C^3H^5	41.	1	41.	2.833
Naphthaline	$\text{H}, \text{C}^{10}\text{H}^7$	128.	2	64.	4.528
Nicotine	$\text{NH}, \text{C}^5\text{H}^6?$	81.	1	81.	5.607
Nitrogen	N	14.	1	14.	.971
— Protoxide	N, NO	44.	2	22.	1.527
— Deutoxide	NO	30.	2	15.	1.039
— Nitrous Acid	N, NO^3	76.			
— Peroxide, Hyponitric Acid	NO^2	46.	2	23.	1.72
— Anhydrous Nitric Acid	N, NO^5	108.			
— Nitric Acid, Hydrate	$2\text{HNO}^3 + 3\text{HHO}$	180.	10	18.	1.273
— Ceanthyllic Acid	$\text{H}, \text{C}^7\text{H}^{13}\text{O}^2$	130.	2	65.	4.535
— Ceanthol	$\text{H}, \text{C}^7\text{H}^{13}\text{O}$	114.	2	57.	4.1
Oxygen	O	16.	1	16.	1.106
Paraffine	$\text{C}^{10}\text{H}^{21}?$	141.	1	141.	10.
Phenyl Hydride (Benzole)	$\text{C}^6\text{H}^5, \text{H}$	78.	2	39.	2.77
— Cyanide (Benzonitrile)	$\text{C}^6\text{H}^5, \text{CN}$	103.	2	51.5	3.7
— Nitrite (Nitrobenzide)	$\text{C}^6\text{H}^5, \text{NO}^2$	123.	2	61.5	4.4
Phosphorus	P	31.	$\frac{1}{2}$	62.	4.42
— Terchloride	PCL^3	137.5	2	68.75	4.875
— Pentachloride	PCL^5	208.5	3	69.5	4.85
— Oxychloride	Cl^3PO	153.5	2	76.75	5.4
Phosphuretted Hydrogen	PH^3	34.	2	17.	1.178
— Hydriodate of	PH^3, HI	162.	4	40.5	2.769
— Hydrobromate of	PH^3, HBr	115.	4	28.75	1.906
Propionic Aldide	$\text{H}, \text{C}^3\text{H}^5\text{O}$	58.	2	29.	2.111
Propylic Alcohol	$\text{H}, \text{C}^3\text{H}^7\text{O}$	60.	2	30.	2.02
Propyl Butyrate (Butyrene)	$\text{C}^3\text{H}^7, \text{C}^4\text{H}^7\text{O}$	114.	2	57.	3.99
Propylene. Tritylene	$\text{H}, \text{C}^3\text{H}^5$	42.	2	21.	1.498
Salicylous Acid	$\text{H}, \text{C}^7\text{H}^5\text{O}^2$	122.	2	61.	4.276
Selenious Acid	SeO	56.	1	56.	4.03

NAME OF GAS.	Composition.	Atomic Weight.	Atomic Measure.	Specific Gravity H = 1.	Observed Sp. Grav. Air = 1.
Seleniuretted Hydrogen	HSe . . .	41.	1	41.	2.795
Silicon, Chloride . . .	SiCl . . .	42.5	$\frac{1}{2}$	85.	5.939
— Fluoride	SiF . . .	26.	$\frac{1}{2}$	52.	3.6
— Chlorosulphide . . .	Si ³ Cl ² S . . .	108.	$1\frac{1}{2}$	72.	5.08
Sulphur	S	16.	$\frac{1}{8}$	96.	6.564
— Sulphurous Acid . . .	SO	32.	1	32.	2.247
— Sulphuric Acid, } Anhydrous }	S, SO ³	80.	2	40.	3.
— — Hydrate	HSO ²	49.	2	24.5	1.58
— Hydrosulphuric Acid	HS	17.	1	17.	1.191
— Chloride	ClS	51.5	1	51.5	3.685
— — Dichloride	ClS ²	67.5	1	67.5	4.7
— Pentasulphate of } Terchloride of } Sulphur }	(ClSO) ² + S, SO ³	215.	4	53.75	4.481
Telluretted Hydrogen	HTe	65.	1	65.	4.49
Tin, Chloride	SnCl	65.	$\frac{1}{2}$	130.	9.2
Titanium, Chloride . . .	TiCl	47.5	$\frac{1}{2}$	95.	6.836
Toluine (Toluol)	H, C ⁷ H ⁷	92.	2	46.	3.26
Retinnaphtha	H, C ⁷ H ⁷ ?	92.	2	46.	3.23
Turpentine, Essence . . .	C ⁵ H ⁹ , C ⁵ H ⁷	136.	2	68.	4.76
Valeryl (compounds of) :					
— Valerine (Amylen)	H, C ⁵ H ⁹	70.	2	35.	2.386
— Valeral	H, C ⁵ H ⁹ O	86.	2	43.	2.93
— Valerianic Acid	H, C ⁵ H ⁹ O ²	102.	2	51.	3.67
Vinyl (Olefiant Gas) . . .	CH ²	14.	1	14.	.967
— Oxide	CH ² , CH ² O	44.	2	22.	1.42
Water	HHO	18.	2	9.	.623
Zinc Ethyl	ZnC ² H ⁵	61.75	1	61.75	4.251

No hypothetical specific gravities are given in this Table. No gases are admitted but such as have been actually produced, and, with a few exceptions, weighed. Hence carbon, fluorine, boron, silicon, antimony, zinc, tellurium, &c., are excluded. The Table therefore presents in its weights and measures a mass of facts. The formulæ alone are theoretical. It enables us to take a comprehensive and trustworthy survey of that chemical region which consists of gases and vapours. It shows us on experimental evidence the weight, the measure, and the ultimate composition, and theoretically the proximate constitution, of about three

hundred well-known volatile bodies. Of that large field we have an accurate bird's-eye view. WHAT DO WE SEE THERE?

First of all we perceive, that all the hydrocarbons that act as radicals, all those which in combination displace an atom of hydrogen or of chlorine, have, in an isolated state, an atomic measure of one volume. They are consequently the equivalents of one volume—of one atom—of one equivalent of hydrogen. That is the case with all the radicals that have yet been isolated; with methyl, whose specific gravity is 15, with ethyl = 29, with allyl = 41, with butyl = 57, and with amyl, whose specific gravity is 71; all these radicals differing so greatly in their density, have an atomic measure equal to that of hydrogen, whose specific gravity is 1. Dr. Frankland fixed the atomic measures of ethyl, of methyl, and of amyl, at two volumes each, and Dr. Hofmann argued that it ought to be four volumes. But from the peculiar point of view which is recommended in this Essay, the theoretical measure is seen to be only one volume, and the experimental evidence proves that each compound radical is equivalent to one volume of hydrogen.

Secondly, it appears that two-fifths of the whole have in common these two properties: they form two volumes of vapour, and they contain two radicals. These radicals are in some cases simple, in others compound; sometimes they are oxidised; sometimes not oxidised; but the compounds all agree in the two leading characters, that there are two radicals in every compound, and that every compound forms two volumes of gas.

A third and very important particular which this assemblage of facts proves is, that oxygen, when contained in a salt, that is to say, when in combination with two radicals, has no gaseous measure. No other element behaves in this remarkable manner. All other elements act as radicals. Oxygen never does so.

These characters fix with precision the idea of a SALT. *It is a compound of two radicals, which may be either simple or compound, oxidised or not oxidised.*

The normal measure of a gaseous salt is *two volumes*, but it is subject to modification from the gasifying powers of different radicals, as shown at pages 138 and 139.

The definition which I have given of the word *salt* brings under that head many substances that are not at present termed salts. That is a desirable result. If it is granted that oxygen is not an essential constituent of a salt, there can be no objection to this plan. But if non-oxidised binary compounds are not salts, then kitchen salt is not a salt. If we fly from this conclusion, and admit chloride of sodium to be a salt, then chloride of calcium is a salt, and if chloride of calcium, why not fluoride of calcium? and if fluoride, why not sulphide?

The suggestions which I have offered in regard to radicals, to formulæ, and to nomenclature, point to very convenient and uniform

methods of arranging and naming salts, in regard to which all existing systems are very defective. Take the case of the salts of calcium: all the non-oxidised salts of that metal are termed salts of calcium, while all the salts in which that metal is assumed (without proof) to be oxidised are called salts of lime. Thus we have:—

CaS = Sulphide of calcium.

CaO,SO^3 = Sulphate of lime.

CaCl = Chloride of calcium.

CaO,ClO^5 = Chlorate of lime.

On the radical theory these salts become:—

CaS = Calca sulpha.

CaSO^2 = Calca sulphete.

CaCl = Calca chlora.

CaClO^3 = Calca chlorite.

There can be no question that the latter names possess over the former the advantages of greater regularity and explicitness.

From these notices of general principles I pass to the investigation of the powers and properties of the chemical elements and their salts.

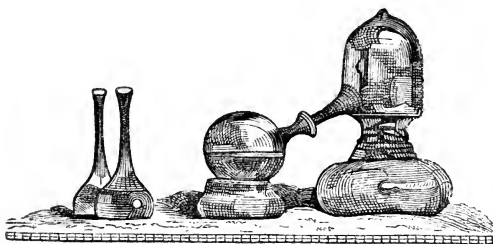

1. OXYGEN.

Symbol, O; Equivalent, 16; Specific gravity of Gas, 16; Atomic Measure when isolated, 1 volume; Atomic Measure when present in Gaseous Salts, 0; Condensing power on Gaseous Radicals, 0.

Occurrence. Oxygen occurs in greater abundance than any other element: probably one-half of the whole earth is oxygen. Water contains $\frac{8}{9}$ of its weight, and air nearly $\frac{1}{3}$ of its bulk, of this element. Sand contains almost $\frac{1}{2}$ of its weight of oxygen, and clay and limestone nearly as much. It is essential to the existence, and enters largely into the composition, of vegetables and animals. See page 10.

Properties. Oxygen forms a colourless, tasteless, invisible, and inodorous gas, which is nearly insoluble in water, has no action on lime-water, and does not change the colour of tincture of litmus. It is distinguished from other gases by supporting combustion with great vigour. If a glowing match is held in a glass containing oxygen gas, the match instantly inflames, and burns quicker and with much greater heat and brilliancy than in common air. Various gases which cannot alone support combustion acquire that property when mixed with oxygen. This is the reason that combustible bodies burn in common air, which contains one part of oxygen gas mingled with about four parts of nitrogen gas. Animals live longer in a given bulk of oxygen gas than in the same bulk of common air.

Oxygen gas is heavier than common air, in the proportion of 16 to 14.47, or 1.10563 to 1.0000, *Regnault*. The number 16 is taken in this work to represent the specific gravity of oxygen gas, in order that the specific gravity and atomic weight may coincide. A cubic inch of oxygen gas, taken when the barometer stands at 30 inches, and the thermometer at 60° F., weighs 0.3418, or nearly one-third, of a grain. Its atomic measure when isolated is one volume. When it is a constituent of gaseous salts it adds nothing to their atomic measure. It has no condensing power on the radicals with which it combines to form gaseous salts. The gases of irregular measure into which it enters are shown at page 139. Its atomic weight is fixed at 16, hydrogen being 1. It has never been procured either in the liquid or solid state.

It has recently been discovered that oxygen possesses magnetic properties, and that the intensity of its magnetism is affected by radiations from the sun. When the atmosphere of the sun is disturbed by those commotions which produce what are popularly called *spots in the sun*, the force of the magnetic radiations is increased, and the magnetism of the earth and of the oxygen of its atmosphere become so intensely excited as to produce in and around our earth the phenomena which

have been called magnetic storms. It has been found that the magnetism of oxygen diminishes with an increase of temperature, and it has thence been suspected that the daily variation in the direction of the magnetic needle is owing to the manner in which the presence or absence of solar radiation influences the magnetic force of the earth and its atmosphere.

Ozone. It is assumed by many chemists that a peculiar substance named *ozone* is a modified form of oxygen, but as the experimental evidence appears to me to show that ozone is an oxide of hydrogen, I shall describe it in the section on Hydrogen.

OXIDES.—When a body is burnt in oxygen gas, it combines with the oxygen and produces a compound which is termed an *Oxide*. This oxide equals in weight the joint weight of the body subjected to burning and of the gas burnt. Thus:—

When sulphur is burnt in oxygen gas to saturation the gas remains unaltered in volume, but its density is increased from 16 to 32. The compound contains, therefore, equal weights of each element, and requires the symbol SO. See page 149.

When carbon is thus burnt in oxygen gas, the volume remains unchanged and the density is increased from 16 to 22. Its composition is, therefore, O, 16 parts and C, 6 parts. When this compound gas is passed over charcoal at a red heat its density becomes reduced to 14, and a volume of it is found, on analysis, to contain O, 8 parts and C, 6 parts. But the atomic weight of oxygen being fixed at 16 and that of carbon at 12, the numbers representing these two compounds must be doubled, when we find the results to be—

For the first gas, $O, 32 + C, 12 = CO^2$; atomic measure two volumes.

For the second $O, 16 + C, 12 = CO$; atomic measure two volumes.

The compound denoted by CO^2 is called carbonic acid, and that denoted by CO is called carbonic oxide. See pages 139 and 143. Why the atomic measure of the oxidised radical SO, is one volume, and that of the oxidised radicals CO and CO^2 is two volumes, is unknown.

Compounds possessing very different properties are formed by the combination of oxygen with other elements. Thus, water consists of oxygen and hydrogen; air of oxygen and nitrogen; sulphurous acid of oxygen and sulphur; aquafortis of oxygen, nitrogen, and hydrogen; caustic potash of oxygen, hydrogen, and potassium; black oxide of copper of oxygen and copper; lime of oxygen and calcium. Some of these compounds are usually called OXIDES, others ACIDS; but none of them exhibit either acid or alkaline properties in the absence of hydrogen. I propose to limit the meaning of the word *oxide* to compounds which contain only one radical in combination with oxygen, and the word *acid* to compounds which contain one negative or acid radical in combination with hydrogen as a basic radical and either with or without oxygen.

The compound which is usually called *peroxide of barium*, and written BaO^2 , is more probably the normal oxide of barium; and its formula should be written BaO , the atomic weight of oxygen being doubled. What is commonly called *barytes*, and written BaO , must be doubled to make it agree with the radical theory, because the atomic weight of the oxygen is doubled. It then becomes Ba^2O , or, as it is more correctly written, Ba_2BaO . This compound is to be considered *a salt*, having Ba as a basic radical, and BaO as an oxidised acid radical.

When a salt of this kind comes into action with a single equivalent of a hydrated acid, it is half neutralised and half converted into a hydrate:—

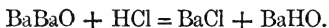

When it comes into action with two atoms of a hydrated acid it is entirely neutralised, and its decomposition is attended with the formation of an atom of water:—

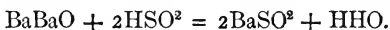

This principle is applicable to all the protoxides. The protoxide of iron, therefore, which is commonly marked FeO , becomes, on the radical theory, Fe_2FeO .

In the same manner, water, which is usually written by English chemists HO , where $\text{O} = 8$, becomes, on the radical theory, H_2HO , where $\text{O} = 16$, each atom of H in both examples being = 1.

When a protoxide combines with water to form a hydrate, such as hydrate of barytes, and which is usually marked thus, $\text{BaO} + \text{HO}$, we must, on the radical theory, consider the two atoms of oxygen $\text{O} + \text{O}$, to be only one atom = O , and must therefore write the formula thus, Ba_2HO , where the compound is represented as *a salt* in which Ba is the basic radical and H , the acid radical. When an atom of a hydrated metallic oxide comes into action with an atom of a hydrated acid, neutralisation is effected, under separation of an atom of water, thus:—

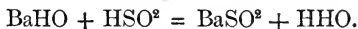

Sometimes when a hydrated protoxide is ignited it gives off water and leaves the anhydrous protoxide. Thus slaked lime becomes quicklime:—

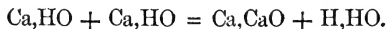

The reaction takes place upon two atoms of the hydrated oxide, because each atom of the hydrate contains only one atom of hydrogen, while two atoms of hydrogen are required to form one atom of water; and it may be taken as a universal rule that, *in all reactions where water is produced, as much decomposition necessarily takes place as will liberate two atoms of hydrogen.*

These remarks refer to protoxides and peroxides. There is an inter-

mediate kind of oxide which is called a *sesquioxide*. The red oxide of iron gives an example of this kind of oxide. In this case, to twice the quantity by weight of the metal of the protoxide there is three times the quantity of oxygen. Thus the two oxides, as usually written, are:—

FeO = protoxide of iron.

Fe^2O^3 = sesquioxide of iron.

Reckoning each atom of oxygen at 16, I must double these formulæ, and then I have for the two compounds Fe^2O and Fe^4O^3 . But this is a case in which the proposed double equivalents of the metal come into play. On that view, the protoxide of iron contains two ferrous atoms to one atom of oxygen, and the sesquioxide contains two ferric atoms to one atom of oxygen (or six ferric atoms to three atoms of oxygen), and the two salts are perfectly parallel and equivalent, and are composed of the same number of ultimate atoms, thus:—

Fe, FeO = protoxide of iron.

Fec, FecO = peroxide of iron.

When I come to treat of the salts of iron, and of the salts formed by chlorine and cyanogen, it will be shown that the atom Fec is under all possible circumstances the equivalent of the atom Fe , and that both are equally the equivalent of an atom of H . The theory of the sesquioxides and of the salts of the sesquioxides are remarkable examples of the prevalence of undoubted fallacies.

Explanation of the terms OXIDATION and REDUCTION.—When oxygen is combined with an element, the element is said to be *oxidised*, and the process of combination is termed *oxidation*; when oxygen is taken away from an oxide, and the element is left in its simple state, it is said to be *reduced*, and the operation is called *reduction*. Thus, if copper is converted into black oxide of copper, the process is one of oxidation. If black oxide of copper is brought into the condition of metallic copper, it is a process of reduction. In these senses the terms seem sufficiently explicit. But they are, nevertheless, often greatly misapplied by chemists in reference to the so-called sesquioxides; and I will give one or two examples to warn the student how necessary it is, in the study of theoretical chemistry, to watch with logical rigour the relations of facts to words, if he would avoid being misled by explanations which mystify what they affect to clear up.

I quote from a popular introductory work, “*Die Schule der Chemie*” of Dr. Stöckhardt:—

“*Experiment.* Dissolve in a test-tube a little green vitriol (sulphate of protoxide of iron) in water, mix the solution with a few drops of sulphuric acid, and then add some solution of chlorine in water. [He gives a figure to show the application of heat to the test-tube.] The mixture immediately acquires a yellow colour. In this process water is decomposed; the hydrogen goes to the chlorine, but the oxygen is

not set free, because it is in presence of a body which indeed already possesses oxygen, but which is capable of taking up more, namely, the protoxide of iron. This becomes more highly oxidised, and the yellow solution then contains the sulphate of the peroxide of iron:—

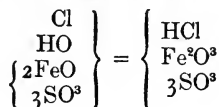

We have, consequently, in chlorine water a powerful *means of oxidation* by which we can easily convert salts of protoxides into salts of peroxides.”

Now, on the radical theory, the explanation of this process is entirely different, as is represented in the following equation:—

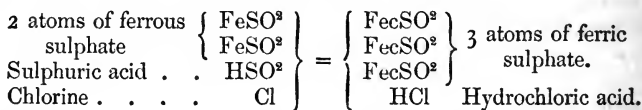

When free chlorine is added to a solution of sulphate of protoxide of iron, namely, Ferrous sulphate = FeSO^2 , you fulfil the conditions which I have described at page 129, namely, you put a limited quantity of basylous radicals into the presence of an excess of acid radicals. The consequence is that the basylous radicals become basylic radicals. In this case $\text{Fe} + \text{Fe}$ become $\text{Fec} + \text{Fec} + \text{Fec}$. These three ferric radicals require three acid radicals to saturate them. Accordingly, some hydrated sulphuric acid = HSO^2 is directed to be added (not anhydrous acid, as shown in Dr. Stöckhardt's formula), the sulphur radical of which goes to the third radical and gives up its hydrogen to the chlorine, which remains in the state of muriatic acid. There is no decomposition of water and no oxidation either demanded or effected. The relation of the oxygen to the several radicals employed in the experiments remains perfectly unchanged during the whole operation. The chlorine removes one basic radical = H, and leaves the sulphur at liberty to act on the ferrous radicals. It is absurd to call this a process of oxidisation, since nothing is oxidised. There is, moreover, no evidence afforded by this experiment of the presence in the original salt of the *protoxide of iron*, or in the new salt of the *sesquioxide of iron*, or of the assumed fact, that in the new salt all the iron, all the sulphur, and all the oxygen is combined into one atom of one salt—the monobasic triacid sulphate of sesquioxide of iron. The radical theory that this conglomeration of atoms forms three salts instead of one salt is simple and more probable.

Just as the process called oxidation, when applied to such cases as the above, signifies the conversion of basylous radicals into basylic radicals, so the converse process of reduction, instead of intimating the sepa-

ration of oxygen, often signifies nothing more than the change of basylic radicals into basylous radicals.

“Fuchs,” says Professor Rose, “has given us an excellent method for the quantitative estimation of iron, founded upon the fact that copper is not dissolved by hydrochloric acid if air is excluded; whilst sesquioxide of iron, if dissolved in this acid, is reduced by copper to protoxide of iron” This is the commonly received notion of reduction.

Now the process in question is, on the Radical Theory, to be explained as follows:—

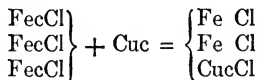

Under the influence of one free cupric radical = Cuc, three ferric radicals Fec^3 become converted into two ferrous radicals Fe^2 , and one atom of the chlorine is thus relinquished to the cupric radical. The presence of hydrochloric acid in excess does not prevent this reaction, because its hydrogen already saturates its chlorine. Here is, evidently, no case of reduction—no taking away of oxygen from anything. The original salt contains no sesquioxides, and the resulting salts contain no protoxides, and it is opposed to the true spirit of science to retain modes of explanation which obscure facts that are otherwise distinctly visible.

Theory of the Oxidising action of Permanganic Acid.—One of the most powerful among the so-called *oxidising* agents is the *permanganic acid*; and as this compound is of great use in centigrade testing, and as its mode of operation illustrates in a remarkable manner the nature of the process of *oxidation*, I will explain its action.

The manganate of potash is represented by the formula KMnO^2 ; the permanganate of potash by the formula KMnc^3O^4 : the last-named salt is that which is used as an oxidising agent, and that to which these remarks apply. The formula usually given to it is $\text{KO, Mn}^2\text{O}^7$; but, on the radical theory, the oxygen is reduced to O^4 , and as the action of the compound depends, as I shall presently show, upon the presence of Mnc^3 , and the reduction of Mnc^3 to Mn^2 , I make a change in its formula.

The permanganate of potash is decomposed by many organic bodies, and by most of those metals which produce two chemical equivalents. I will instance *oxalic acid* and *ferrous salts*:—

Example A.

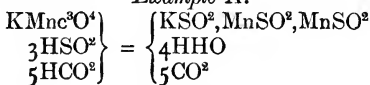

Example B.

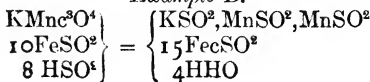

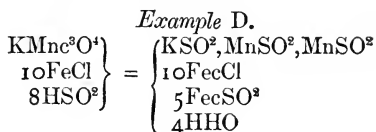
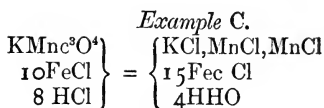

In all the examples a large supply of hydrated acid is present for two purposes: first, to prevent the deposition of insoluble hydrates of manganese; secondly, to provide the hydrogen that is required to take up the liberated oxygen. In every example all the oxygen of the permanganate goes to form 4 atoms of water; none of it becomes attached to the bodies which are commonly said to be oxidised by its decomposition; which in these instances are the carbon and the iron.

In every example the three manganic radicals Mnc^3 become changed into two manganous radicals, Mn^2 , and these, with the potass radical K, take up three of the acid radicals that are set free by the withdrawal of the hydrogen.

It is quite evident that the acting quantities in every experiment are regulated by the necessity of supplying each of the four atoms of liberated oxygen with two atoms of hydrogen to convert it into water. All other effects depend upon this fundamental action.

In Example A the oxygen takes 3H from the sulphuric acid, and then 5H from the oxalic acid, separating 5 atoms of carbonic acid in the state of gas. There is clearly no ground for stating that this carbonic acid is indebted for any part of its oxygen to the permanganate, since the relation by weight of the carbon to the oxygen is the same in oxalic acid and in carbonic acid.

In Example B, 10 atoms of ferrous sulphate are changed into 15 atoms of ferric sulphate; but though it is true that in the ferrous salts there are collectively 20 atoms of oxygen, and in the ferric salts 30 atoms, it is clear that none of this oxygen is derived from the permanganate, which possesses in all only 4 atoms, and gives up the whole of that to form water. The common explanation which is given of this reaction, namely, that the protoxide of iron is converted into the peroxide at the cost of oxygen supplied by the permanganic acid is therefore unquestionably erroneous. The circumstance that in this example the action falls upon 10 atoms of FeSO^2 depends upon two particulars; first, that H^8 being abstracted by O^4 , leaves at liberty 8 atoms of SO^2 ; of this quantity of oxidised radicals 3 SO^2 are taken up by the 3 basic radicals supplied by the decomposed permanganate and 5 SO^2 are left to be supplied with 5 other basic radicals; secondly, as Fe^2 yield Fec^3 , or

Fec^1 free, so 10 atoms of Fe must be acted upon to liberate Fec^5 , the quantity of radicals required to neutralise the 5 atoms of SO^2 .

In Example C the action is exercised upon acids and salts that contain no oxygen. How are we, in this case, to explain the process by which protoxide of iron is converted into peroxide of iron?

In Example D we have a specimen of the combined action of an oxidised acid and an acid that is non-oxidised. This difference has no effect on the general action. There is the same product of water, and the same number of individual salts produced as in examples B and C.

All the examples concur to prove that the prime occurrences in these reactions are the conversion of manganic radicals into manganous radicals, and of ferrous radicals into ferric radicals; that these conversions are effected by the action of acid radicals which are set free by the abstraction of H^9 by the O^4 which is abandoned by the decomposed permanganate of potash. The alleged *oxidation* of carbon and iron in these processes is an entire misapprehension of what actually occurs.

It is of the greatest importance for the young chemist to acquire a clear idea of what takes place in these cases of so-called oxidation and reduction. The slovenly method of stating facts, and the careless quotation of illogical arguments, in which many writers indulge, render it indispensable for every student to acquire habits of independent judgment on all points of theory, and to that end the nature of such processes as these must be thoroughly comprehended.

I refer the reader who wishes to examine the experimental evidence more extensively to my Treatise on the Radical Theory.

PREPARATION OF OXYGEN GAS.

I shall describe the preparation of this Gas, and the conduct of experiments with it at considerable length, in order to be enabled to give a description of the pneumatic apparatus employed for experiments with gases in general. The preparation of other gases will be described more briefly.

A. MATERIALS FROM WHICH OXYGEN GAS IS PROCURED.

a). *From Chlorate of Potash.*—Equal parts by weight of Chlorate of Potash and Black Oxide of Copper, well dried and finely pounded, are intimately mingled. This mixture is well adapted for the extemporaneous preparation of oxygen gas. When exposed to a gentle heat, over a small spirit lamp, it becomes red hot, and disengages a rapid current of pure oxygen gas. The best vessel to use for the experiment is a stout tube of hard German Glass, about an inch wide and six inches long, connected by a long and sound cork with a gas-leading tube, 20 inches long and of not less than half-an-inch bore: a

narrower gas-leading tube, such as is used for hydrogen and other gases that are prepared in the wet way, will not carry off oxygen gas with sufficient rapidity.

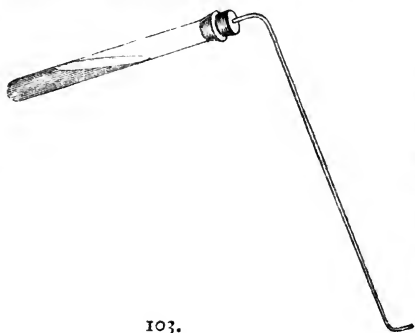

103.

The tube-retort may be half filled with the mixture, and must be placed nearly in a horizontal position, over a small spirit-lamp. The incandescence appears very soon after the flame is applied to the tube. It rapidly extends through the whole mixture, and the operation is then at once ended; the discharge of gas ceases suddenly. When the cessation is observed, that is to say, when the gas ceases

to bubble up through the water of the gas-receiver, the distilling apparatus must be withdrawn from the trough, otherwise the cold water will soon rise up into the tube and crack it. What remains in the tube is a dry coarse black powder, resembling gunpowder, which does not adhere to the glass, but can be readily shaken out, provided the mixture used for preparing the gas was perfectly dry. It consists of black oxide of copper and chloride of potassium. The latter can be removed by washing, and the former recovered for a repetition of the process, for which it serves any number of times; so that the use of the oxide of copper does not increase the cost of the oxygen gas.

The composition of chlorate of potash is as follows:—

K	39·	or	·318
Cl	35·5	„	·290
O ³	48·	„	·392
	122·5		1·000

So that 1 grain of chlorate of potash gives ·392 grain of oxygen, leaving ·608 grain of chloride of potassium, KCl. Estimating the weight of 1 cubic inch of oxygen gas at ·34 grain, this product is equal to 1·153 cubic inches. I find, practically, that 2 grains of the black mixture above described, containing 1 grain of chlorate of potash, give just this quantity of oxygen gas. Hence it appears, that in this process, the chlorate of potash is completely decomposed, and its oxygen entirely discharged in the state of gas; while, notwithstanding the incandescence that occurs, the black oxide of copper remains unchanged in composition and properties, and merely mixed with the chloride of potassium produced from the decomposed chlorate of potash. Thus, $\text{KClO}_3 = \text{KCl} + \text{O}_3$.

Advantages of this Process.—It is easy to obtain materials of such a quality as always to ensure the prompt production of pure gas. Excepting a trace of chlorine and a little sublimed salt, both of which are absorbed by the water of the pneumatic trough, the oxygen gas produced by this process is free from all impurities, especially from carbonic acid; one economical advantage of which is, that it can be used for many class experiments, largely diluted with common air. No distilling apparatus is required except a small glass tube, which is not injured by the operation. There is no expense incurred for fuel, no dirt produced, and no danger to be apprehended.

The process is not only of easy and rapid execution, but is one that can be always depended upon, so as to save loss of time and materials. When any quantity of oxygen gas is required, it is only necessary to gauge the vessels that are to be filled, and to weigh off 1.75 grain of the black mixture for every cubic inch of gas required. 175 grains of the mixture produce 100 cubic inches of gas in five minutes. With a charge of 486 grains of the mixture in a six-inch tube, a receiver of the capacity of a gallon can be filled with oxygen gas in less than a quarter of an hour, without previous preparation and without fail. There need consequently be no waste either of time or materials in preparing oxygen gas by this process. By many experiments with different quantities of the mixture, I have ascertained that the process is always to be depended upon for producing a determinate bulk of gas from a given weight of materials. The cause of this certainty in the result is the remarkable incandescence which takes place when the mixture is heated. This ensures the prompt and total decomposition of every particle of the chlorate of potash submitted to experiment.

It is convenient to mark upon the bottle in which the black mixture is kept, the weight of it necessary to be taken for the purpose of filling with oxygen gas the principal gas-holders and receivers which may happen to be in common use. The quantity of mixture in grains required for each vessel is found by multiplying the capacity of the vessel, expressed in cubic inches, by 1.75. Thus, if 100 cubic inches of gas are required, the quantity of black mixture to be taken is 100×1.75 (or $100 + 50 + 25$) = 175 grains. For a cubic foot of gas, the quantity of mixture required is 1728×1.75 (or $1728 + 864 + 432$) = 3024 grains. In other terms, if x is the capacity of a gas-holder, expressed in cubic inches, then the arithmetical equivalents of $x + \frac{1}{2}x + \frac{1}{4}x$ show the number of grains of the black mixture necessary to be taken to fill the gas-holder with oxygen.

Oxygen gas can be prepared from chlorate of potash by heating it alone in a glass vessel. But the process is very troublesome, and generally attended by the destruction of the retort. This arises from the violent boiling of the fused salt at a certain period of the operation. Several different powders can be used to abate the effervescence,

namely, chloride of potassium, peroxide of manganese, brick dust, and pumice-stone; but these are all inferior in convenience to the black oxide of copper. They demand more heat and disengage more chlorine. When pumice-stone is used the chloride of potassium is often strongly alkaline. Next to oxide of copper, the best thing to use is good peroxide of manganese, which must be quite free from carbonates. It is a very cheap substance, and may be thrown away after being once used. This saves the trouble which is caused by washing and drying the black oxide of copper after each experiment.

To find if Peroxide of Manganese is free from Carbonates.—Mix the powder with water in a test-glass and let it settle. Then add to the water a little nitric or muriatic acid. If effervescence occurs and a colourless gas is given off, the oxide contains carbonates. Such manganese is not worth the cost and trouble of purification, because good manganese is very cheap and easily procurable.

When oxygen gas is wanted only at distant intervals, it does not answer to keep the mixture ready-made, because it readily imbibes moisture, especially if oxide of copper is used. It is better to keep the powders apart, and to dry both thoroughly *before mixing them* for each distillation. If moisture is present, it is liable to cause the fracture of the retort. I have heard of explosions having taken place during the preparation of oxygen gas in this manner. But these explosions must have arisen either from the delivery-tube being too small, or from the neglect of the operator to dry the powders before mixing them. Of course the most careless operator will take care that no charcoal or other organic substance is present in his mixture, unless he desires expressly to prepare an explosion.

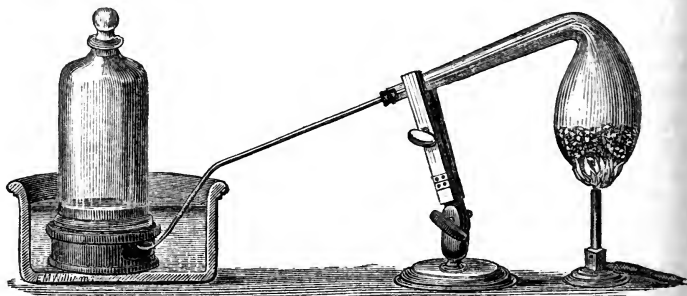

104.

When a large quantity of gas is required, a hard glass retort or long-necked flask may be used. The end of the gas-leading tube, of half an inch or more in bore, should be pushed into the body of the retort or flask, and the retort and tube may be connected together by a cork, or a short tube of vulcanised india-rubber.

Figure 104 represents an apparatus of this description ; consisting of a retort, and a long gas-delivery tube. The tube is pushed far into the retort, or flask, in order to keep the hot gas as much as possible from contact with the cork connector. The wooden support shown in this figure is very convenient in the arrangement of small distilling apparatus. The heat is supplied by means of a Bunsen's gas-burner.

A gas-holder, of the capacity of six gallons, or about 1700 cubic inches, may be filled with oxygen gas in ten minutes, using a retort of this sort, and a charge containing 4 ounces each of chlorate of potash and peroxide of manganese.

When five or six cubic feet of gas are required, namely, to fill the gas-bag of a magic-lantern, to serve for a two-hours' lecture, a copper still may be used over an ordinary fire, and the gas should be passed through water, in a wash-bottle, to cool it before it is passed into the cloth gas-bag.

OTHER PROCESSES FOR PREPARING OXYGEN GAS.

b). *From Peroxide of Manganese and Sulphuric Acid.*—Pour oil of vitriol into a tubulated retort, through a funnel, till the retort is one-third filled. Take an equal weight of black oxide of manganese, and pour it into the retort through a warm, dry funnel, taking care to shake the retort from time to time, so as to incorporate the two ingredients thoroughly. Apply heat by means of a large lamp or charcoal fire, and let it be well sustained, so that the water of the pneumatic trough may not run back into the retort and break it. The dry sulphate of manganese is afterwards removed from the retort, by being soaked and softened with water. It is however difficult to prevent the bursting of the retort by the expansion of the sulphate of manganese, so that, since the reduction in price of the chlorate of potash, and the discovery of its ready decomposition in the presence of the oxides of copper and manganese, this process is seldom used.

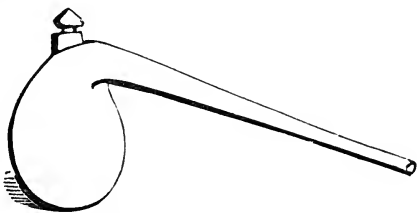

105.

Theory :—Two atoms of peroxide of manganese, and two atoms of hydrated sulphuric acid, produce two atoms of sulphate of manganese, one atom of water, and one atom of free oxygen.



In this case, and in all the equations which follow, the atomic weights are those which are quoted in the Table given at page 123, column 3,

and the constitution of the different compounds is represented in accordance with the radical theory.

The reaction takes place between two atoms of each ingredient employed, for the reason explained at page 154, namely, because two atoms of hydrogen are necessary to produce one atom of water, and in all reactions, where water is produced, as much decomposition necessarily takes place as will liberate two atoms of hydrogen. We might, *à priori*, expect this decomposition to be:—

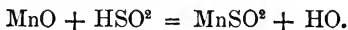

But HO, the simple oxide of hydrogen, is not permanent—cannot exist for an instant—in the presence of oxide of manganese, but is resolved into water and oxygen gas. $\text{HO} + \text{HO} = \text{HHO} + \text{O}$.

c). *From Peroxide of Manganese.*—When a large quantity of oxygen gas is required, it is usual to ignite dry peroxide of manganese in an iron retort, or a quicksilver bottle, or a gun-barrel, placed in a furnace or open fire.

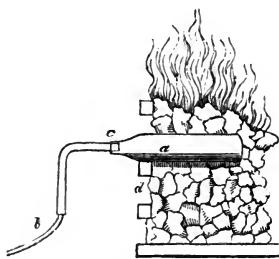

Letter *a*, in figure 106, is a cast-iron bottle, *c* an iron pipe screwed or ground to fit it, *b* a tube of lead proceeding to the gas-holder, *d* a section of a common fire-place.

The peroxide of manganese should be previously washed with diluted nitric acid, to free it from carbonate of lime, &c.

Theory:—Peroxide of manganese, MnO , when ignited, does not become reduced to the protoxide MnMnO by loss of half its oxygen; but is reduced to some intermediate state, according to the temperature employed.

Thus it may be:

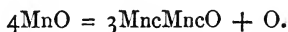

In that case, it gives off one-fourth of its oxygen. When it is more strongly heated, the decomposition becomes:



In which case it gives off one-third of its oxygen. The compound marked MnMnc^2O^2 is a double salt of the form $\text{MnMncO} + \text{MncMncO}$, a form intermediate between the so-called sesquioxides and the protoxides, a form of double salt which is common to iron and to other metals which produce sesquioxides as well as to manganese.

The mineral called Manganite is a hydrate corresponding to the

oxide $MnMnc^3O^2$. Its formula is $HMnc^3O^2$. When this mineral is ignited its decomposition takes place thus :

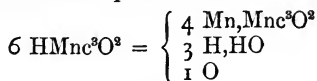

Here we perceive that only one-twelfth part of the oxygen is set free.

The Manganite is equally disadvantageous for the preparation of chlorine gas. To set free 1 atom of chlorine = Cl, you must use 1 atom of MnO, weighing 43.5, and 2 atoms of HCl, weighing 73; whereas 1 atom of $HMnc^3O^2$ weighs 88, and requires 3 atoms of HCl, weighing 109.5, for the same end. Hence there is an additional loss of half the manganese and one-third of the acid. The equations are :

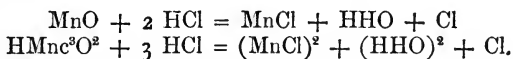

The constitution of manganite is similar to that of permanganic acid, except that it possesses only half as much oxygen to the same quantity of radicals.

d). *From Red Oxide of Mercury.*—Put a small quantity of red oxide of mercury into a very small hard glass tube, and apply heat by means of a large spirit-lamp, or a chauffer. The oxide is decomposed, metallic mercury volatilises and condenses in the receiver, if one is placed to receive it, and oxygen gas, in a state of great purity, is disengaged from the extremity of the apparatus.

Theory :— $HgcHgcO = Hg + O$.

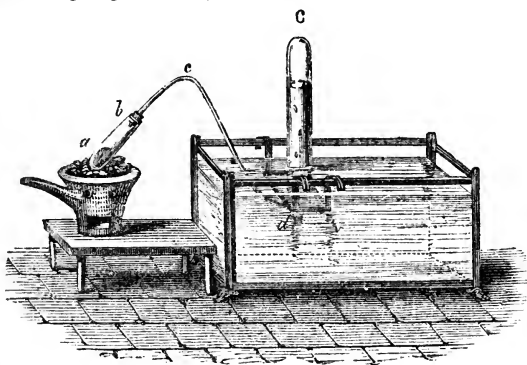

107

Figure 107 represents an apparatus that may be used for this experiment. *a* and *b* represent the tube-retort; *c*, the gas-delivering tube;

V, a pneumatic trough formed of plate-glass, bound with brass edges; *d*, is a sliding shelf; and *C*, the receiver for the gas. This kind of pneumatic trough is well adapted for lectures, because it permits the transfer of the gas to be distinctly seen, but it is expensive.

e). *From Oxide of Silver*.—Oxide of Silver heated in a glass tube gives off pure oxygen gas, and leaves metallic silver. *Theory* :—

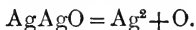

The apparatus represented on page 76, the tube being of thin hard Bohemian glass may be employed for reducing small quantities of the oxides of mercury and silver. A slip of wood inflamed at one end and blown out, but inserted into the tube while still retaining a red-hot point, will be immediately re-inflamed by the oxygen gas.

f). *From Nitrate of Potash*.—Saltpetre distilled in earthen retorts at a red heat gives off impure oxygen gas.

Theory :— $\text{KNO}^3 = \text{KNO}^2 + \text{O}$. That is to say, one-third of the oxygen is driven off, and the *Nitrate* is reduced to the *Nitrite* of potash (using the existing nomenclature). At a greater heat it is resolved into potash, nitrogen, and oxygen: $2\text{KNO}^3 = \text{KKO} + \text{N}^2 + \text{O}^5$. The oxygen prepared by this process always contains nitrogen, and the distilling vessel is commonly destroyed, because the potash combines with the silica of the vessel.

g). *From Water by Electrolysis*.—This process will be described in the section on Hydrogen.

B. METHODS OF COLLECTING GASES.

When glass jars, or any other vessels, open only at one end, are plunged under water, and inverted after they are filled, they will remain full, notwithstanding their being raised out of the water, provided their mouths be kept immersed; for, in this case, the water is sustained in the jars by the pressure of the atmosphere, in the same manner that mercury is in a barometer. It may without difficulty be imagined, that if common air, or any other fluid resembling common air in lightness and elasticity, be suffered to enter these vessels, it will rise to the upper part, and the water will subside. If a bottle, or cup, or any other vessel, in that state which is usually called empty, though in reality full—of *air*, be plunged into the water with its mouth downwards, scarcely any water will enter, because its entrance is opposed by the elasticity of the included air; but if, while the vessel is immersed, its mouth be turned upwards, the air will rise in bubbles to the surface of the water, leaving the water to occupy its place in the vessel. Suppose this operation to be performed under one of the jars which are filled with water, the air will ascend as before; but, instead of escaping, it will be detained in the upper part of the jar. In this manner, therefore,

we see, that air may be emptied out of one vessel into another by an inverted pouring. Just in this manner are gases collected in vessels placed in what is termed a pneumatic trough: the jars which are to receive certain elastic fluids, are filled with water, and placed, mouth downward, upon a shelf, and the necks of retorts, and ends of tubes, from which gases are evolved, are directed below holes made in the shelf under the jars; then the gases, as they issue forth, rise in bubbles through the water, enter the jars, driving thence the water, and occupying its place. When, therefore, the jars are thus emptied of water, they are filled with gas.

The pneumatic trough is simply a wooden tub, or vessel of tin-plate, filled to within two inches of its top with water. It should be provided with a shelf, placed an inch below the surface of the water, or with a wooden block, cut into the form shown by the figure, and plugged with lead to make it sink in water. When you wish to fill a jar with gas, you place it full of water, in an inverted position, over the hole cut in the block, and you direct the point of the tube whence the gas is to issue into this same hole. The water in the tub must rise about an inch above the top of the block. The size or form of the trough is quite immaterial. A wash-hand basin answers the purpose very well for jars of a small size. The annexed figure exhibits the mode of putting together a pneumatic apparatus, such as has been here described.

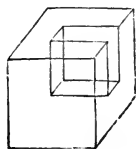

108.

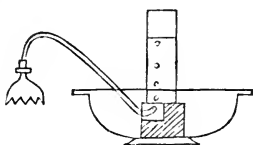

109.

I shall describe a different sort of shelf and pneumatic trough presently.

RECEIVERS FOR GASES.—Any kind of glass vessel can be employed as a *receiver* for gases: in the last figure, a plain cylinder is represented; but certain experiments require vessels of a particular size and form. This will be adverted to when necessary. Lecturers on chemistry generally employ a metallic gas-holder to contain large quantities of oxygen or hydrogen gas. If at any time a large quantity of oxygen gas is prepared, when no gas-holder is at hand, it may be put into glass bottles, and corked up. Each bottle should be placed aside, bottom upwards, with the mouth plunged into a little pot of water. The gas will not escape.

Various useful forms of receivers for gases are represented by figures 110 to 116.—(See p. 168.)

Before filling a stoppered deflagrating jar with gas, the jar should be cleaned, and its condition be carefully examined, particularly as to the accurate fitting of the ground stopper. To this end, after the jar is cleaned, the stopper and the ground mouth of the jar should be rubbed

with tallow or pomatum (using the tallow-holder described at p. 100);



110.



111.



112.



113.



114.

after which, upon turning the stopper in the mouth of the jar, it will be seen if it presses everywhere alike. The jar should then be filled with water and placed on the shelf of the pneumatic trough. If there is any leakage, the pressure of the atmospheric air will cause the water to sink in the jar. In such a case the stopper must be re-ground before the jar is used.



115.



116.

When a bottle has been filled with gas in the manner described above, it may be corked



117.

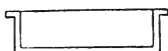

118.

under water, and then removed from the trough. If a jar with a wide mouth has been filled, you must fill a shallow tray (figures 117 and 118) with water, and slide the filled jar from the shelf into the tray, the small quantity of water contained in which will prevent the escape of the gas from the jar. (Figure 119.)

This removal of jars from the pneumatic trough in trays requires additional precautions when the jars are open at both ends, and have either ground stoppers, like figures 110 and 115, or are closed with flat discs of ground glass, such as *c*, fig. 116. When you slide the jar off the shelf down into the water,



119.

you must take care that the upward pressure of the gas, condensed by that movement, does not lift up the glass stopper or cover of the jar. To prevent that accident, a finger should be placed on the cover, or stopper, while the hand holds the jar by the neck.

When you want to transfer gas from a wide-mouthed into a narrow-mouthed vessel, you must hold a funnel in the mouth of the latter. All transfers of gas must be effected under water, and, as it has been expressed above, by an inverted pouring. As water emptied in air descends, so air emptied in water ascends. This is the principle upon which depends the decantation of gases.

Filling of Bladders with Gases.—As it is frequently necessary to fill bladders, or indian-rubber bags, with gases, I shall describe the method of doing it. The following figure represents an apparatus employed for this purpose. *a* is a glass receiver, supposed to contain gas; it is open at the bottom, and provided with a brass cap and stop-cock at the top. A vessel six inches in diameter and twelve inches high, is sufficiently large for such experiments. *d* is a bladder, in the mouth of which a stop-cock is fastened by means of a ferrule. *f* is the side of a pneumatic trough. *h* is the shelf, *g* the level of the water, *e* and *b* are the stop-cocks by which the bladder and receiver are connected.

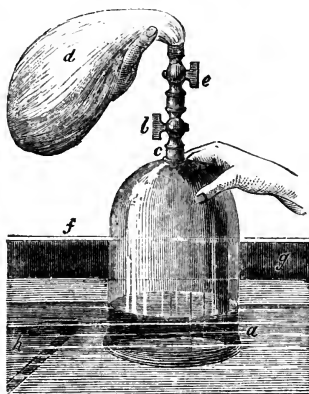

120.

Moisten the bladder with water to render it flexible, squeeze it close to expel the common air from it, then shut the stop-cock *e*, and screw it to the stop-cock *b*, on the top of the receiver, which is supposed to be placed on the shelf in the trough. Next, open both the stop-cocks, hold the apparatus in the manner shown by the figure, gently slide the receiver off the shelf, and press it down into the water; the gas will soon enter and fill the bladder, being forced through the opening by the upward pressure of the water. The stop-cocks are then to be closed, the receiver replaced on the shelf, and the two vessels disunited. Previously to undertaking experiments on gases, the young student should accustom himself to the dexterous management of gases, by performing the processes of decantation, filling of bladders, &c., with common air.

Several contrivances for use instead of bladders may now be procured. *a*). A solid bag of vulcanised caoutchouc, which expands when gas is forced into it. *b*). A bag of thick goldbeater's skin, formed like

the hydrogen balloon. This is elegant and handy, but expensive and fragile. *c*). A bag made of water-proof cloth, made in a pillow shape. This is durable, and can be conveniently pressed between two boards, or by the hand. See figure 158. Gas can be conveyed from any of these bags by means of vulcanised indian-rubber tubes.

When bladders are used, they are more convenient to handle after they have been well rubbed with a mixture of one part of glycerine with two parts of water.

STONEWARE GAS-HOLDER.

In all cases where a *series* of experiments with the same gas are to be performed, as when a teacher has to demonstrate the properties of oxygen gas or hydrogen gas, it is convenient to begin by preparing a quantity of gas sufficient for the performance of the whole series, and then to proceed uninterruptedly with the experiments. I shall here describe a cheap and handy apparatus for storing gas for this purpose.

Letter *a* in figure 121 is a stoneware bottle of about a gallon and a

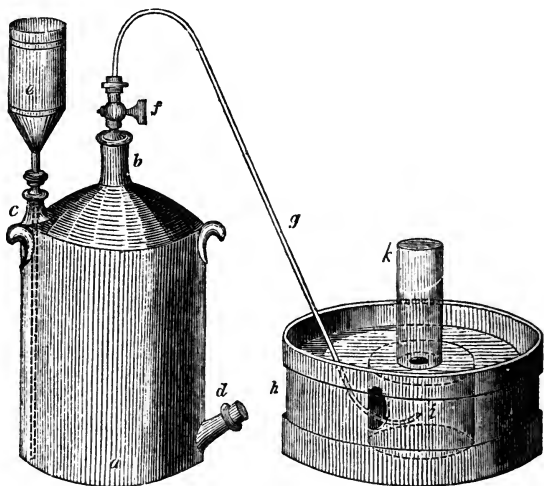

121.

half capacity, or about ten inches in diameter and thirteen inches in height. It is furnished with three necks, *b*, *c*, *d*. The neck *d* is fitted with a cork. The neck *b* is provided with a stop-cock, *f*, which is cemented into it. The neck *c* is cemented round the upper end of a metal tube,

which descends very nearly to the bottom of the bottle. There is a coupling-screw soldered to the top of this tube, to which the large japanned iron funnel *e* can be connected when necessary. *g* is a flexible metallic pipe two feet in length, connected to *f* by a screw.

To fill this Gas-Holder with Water.—Close the neck *d* with its cork. Open the stop-cock *f*, and pour water into the funnel *e*, till it runs out at *f* (the tube *g* being supposed away).

To fill the Gas-Holder with Gas.—Close the stop-cock *f*. Take out the cork at *d*, and pass into the neck *d*, the delivering-tube which comes from the bottle in which the gas is being prepared. The gas will then rise in the vessel *a*, and an equivalent bulk of water will flow out at *d*. Of course, the gas-holder must be placed during this process over a tub sufficiently large to receive the water that runs out. The quantity of the water thus collected, shows the quantity of gas that has entered the gas-holder. When water ceases to run out of the mouth *d*, notwithstanding the continuance of the delivery of the gas into it, the gas-holder is filled with gas.

STONEWARE PNEUMATIC TROUGH.—Before noticing the method of expelling the gas from this gas-holder, it is proper to describe a new form of pneumatic trough which is to be used with it.

h, in figure 121, is this trough. It is a pan of stoneware eleven inches in diameter, and five inches deep. The shelf for supporting the jars in this trough, and for gathering the gas beneath the jars, is the most peculiar part of it. This is represented by letter *i* in the above figure, and under different points of view by figure 122. This shelf is an inverted stone pan, cylindrical on the outside, but shaped like a bee-hive within. It

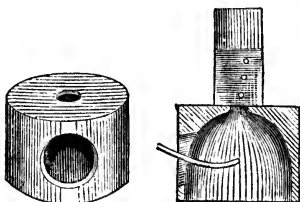

122.

is four inches broad, and three inches and a half high, or any other convenient size. On the side it has a round opening of two inches diameter to admit the entrance of retort necks and gas-delivering tubes, and in the top it has an opening of half an inch in diameter, to permit the passage of gas from the bee-hive below, into the jars placed upon it. When this shelf is put into the trough, but close to one side of it, there is room left for working with pretty large cylinders. The gas is collected very effectually from any sort of delivering-pipe, and with great readiness, and without any loss, it is conveyed even into narrow-mouthed flasks, placed in the position indicated by figure *k* in figure 121.

To pass Gas from the Gas-Holder into a Jar.—The flexible metal-pipe is first placed in the position shown by figure 121, and is adjusted

to the bee-hive and trough, which is filled with water to within half an inch of the top. The jar is filled with water, inverted, and placed upon the bee-hive in the trough. The funnel *e* is filled with water. You have then only to open the stop-cock *f*, when the gas immediately passes into the jar *k*. When the jar is as full as you wish it to be, you close the stop-cock *f*.

In experimenting with this apparatus it is advisable always to use cylinders of a smaller capacity than the funnel *e*, in order that one filling of the funnel may be sufficient for each experiment.

To fill a Bladder or a Balloon with Gas from the Gas-Holder.—Attach the compressed bladder to the end of the pipe *g*, pour water into the funnel *e*, and open the stop-cock *f*.

In the same manner can the gas be forced out upon any given object. Thus, oxygen gas can be forced out upon burning charcoal to cause the fusion and combustion of metals, &c.

Figure 121 was drawn and the above description was written before the invention of vulcanised indian-rubber tubes, the use of which has much facilitated operations with gases. Flexible caoutchouc tubes are now used instead of the metal tube described above. The bee-hive shelf, of which this was the first published description, has now been adopted in almost every chemical laboratory, and is made of a great variety of sizes to suit jars of different diameters.

GLASS GAS-HOLDERS.

I have made many attempts to prepare glass gas-holders on the plan of the stoneware gas-holder, but these have generally been unsuccessful in consequence of the impossibility of getting the glass-maker to put on properly the neck *d* of figure 121. Nine times out of ten they either put on this neck at a wrong angle, or else anneal it so badly that the vessel cracks and is destroyed after very little using. The stoneware gas-holder has the disadvantage of being opaque, so that you cannot see the height of the gas in it. Attempts to rectify this defect, by applying a gauge-pipe, make this kind of apparatus more expensive than one formed of metal. As the result of a good many trials of different gas-holders, I now recommend the *school gas-holder*, figure 127, as an economical and useful kind for class experiments with moderate quantities of gas.

PEPYS'S GAS-HOLDER.

The most convenient size of this apparatus is when the receiver *a*, figure 124, is sixteen inches in height and twelve inches in diameter. The apparatus is unwieldy if larger. Its use is pretty much the same as that of the stoneware gas-holder already fully described, save that

the pneumatic trough, *b*, is in this case situated above the gas-holder. To fill it with water, close the neck *g*, put water into the cistern *b*, close *d*, and open *f* and *c*. The water descends by *s*, and the air escapes by *f*. When it is full up to *f*, close that cock and open *d*, by which the rest of the air will escape. *e* is merely a support. *k* is a glass-tube by which the height of the water in *a* is seen. It has a scale showing the number of cubic inches of air contained in *a* above the level of the water. The tube *i* is open at the bottom and connected with the cock *c*, *s*. The

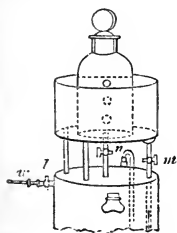

123.

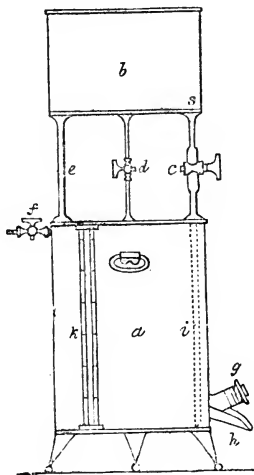

124.



125.

end *r*, and the end *q*, of the pipe *p*, attached to the funnel *o*, figure 125, are adapted to the opening *s*. When *r*, the end of the funnel, is put into the socket *s*, and the funnel is filled with water, the gas contained in *a* is forced out through *f* or *d*, with a pressure of a column of six feet of water. The spout *h* is intended to carry off the water that escapes from the opening *g*, during the collection of a gas. To fill a receiver with gas from this apparatus, the receiver is filled with water and inverted over the pipe *d* (or *n* in figure 123). Water is then poured into the trough, or into the funnel, and the stop-cocks *d* and *c* (or *n* and *m*) are both opened. The gas then rises in the glass-receiver, as shown by figure 123.

SIR HUMPHRY DAVY'S GAS-HOLDER.

Figure 126 is copied from Sir Humphry Davy's *Chemical Philosophy*. It represents a gas-holder by which a stream of oxygen gas may be

thrown upon ignited charcoal, for the purpose of fusing or burning bodies, &c.

This apparatus is constructed, like an ordinary gasometer, of a bell-jar counterpoised over a water-tank. There is commonly a hollow block in the middle of the tank, to lessen the weight of water.

To fill the receiver with water.—Remove the blowpipe, open the stop-cock, and depress the bell-jar into the water. The air escapes by the stop-cock. The jar may be forced down by the hands, or by lessening the weights in the two pans, or by putting weights on the top of the jar, which must be made flat to receive them.

To fill the receiver with gas.—Attach the gas-delivery tube, which comes from the gas-generator to the stop-cock, either by screws or by a connector of caoutchouc, and add to the pans sufficient weights to counterbalance the receiver, so that it may readily rise with the pressure of the incoming gas.

This form of gas-holder is more expensive than the other forms. The advantage it offers over the others is, that its water always remains in the same place, and does not require to be alternately put into and expelled from the gas-holder into another vessel. It is, consequently, generally employed when very large quantities of gas are required.

GRIFFIN'S SCHOOL GAS-HOLDER.

This gas-holder differs from that of Pepys's only in the absence of the inconvenient upper cistern. It is usually made of japanned tin-plate or zinc; in size, eighteen inches high and ten inches and a half diameter; its contents about 1,500 cubic inches. The gauge-pipe is of stout glass, about half-an-inch in the bore, and is graduated into spaces of fifty cubic inches. It is fixed in its place by rings of caoutchouc, and if broken can be easily replaced, the upper collar being closed by a brass screw *h*.

The gas is introduced, as already explained, by the pipe *a*, and is expelled through the caoutchouc-tube *l*, by the pressure of water

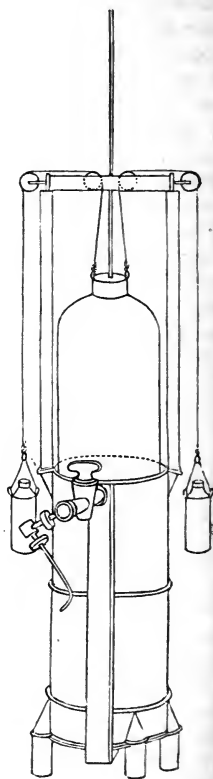

126.

in the funnel, the pipe of which reaches to the bottom of the gas-holder. At the end of the caoutchouc-pipe, *l*, is a glass tube, *d*, which can be held by a suitable support in such a position as to deliver the gas where it is required. The stop-cock, *e*, is replaced by a blank nut, when the apparatus is used as a gas-holder. The funnel unscrews at *f*, for the convenience of travelling, or to admit the insertion of another length of pipe when greater pressure is demanded.

After what has been already said, it is needless to describe how either gas or water is to be put into, or expelled from, this apparatus.

Use of the School Gas-Holder as an Aspirator.—Screw in the stop-cock, *e*, without the tubes, *i*, *k*, remove the tube, *l*, close the pipe, *a*, fill the gas-holder with water, and connect the stop-cock, *g*, with the vessels through which air is to be drawn. Turn on the stop-cock, *e*. The water will then escape, and air will be drawn through the stop-cock, *g*, to replace it in the gas-holder. When the water is exhausted, close the stop-cocks, *g* and *e*, open the screw, *h*, and fill with water by the funnel.

Use of the School Gas-Holder in Hydrostatic Experiments.—Attach a flexible vulcanised caoutchouc-tube, *i*, to the stop-cock, *e*. Fill the gas-holder and funnel with water. By this means the water can be conveyed in any direction, and various problems in hydrodynamics can be illustrated.

Put the gas-holder on a high shelf, carry the flexible pipe down to the ground and attach it to a jet, such as a bent glass tube with a fine orifice, *k*. Turn on the water, upon which a fountain will be produced more or less high, according to the length of the pipe, *i*, and the height of the water in the funnel, *c f*.

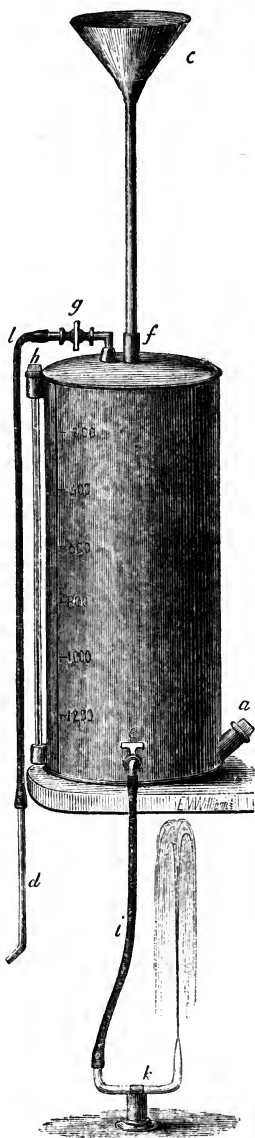

WILLIAMS'S GAS-HOLDER.

Professor Williams, of Birmingham, has recommended the employment of a gas-apparatus on the following plan, which can be used with mercury, if made of small size.



128.

As the gas is generated, it passes from the gas-tube into the receiver, displacing the water by forcing it up the water-tube. The outer end of this tube should dip into the fluid contained in the vessel which receives the water driven out, in order to prevent regurgitation of air, which would otherwise take place when the gas in the flask and receiver is cooling, after the generation of gas has ceased. When the gas is to be used immediately, it will be found convenient to slip a piece of plate-glass over the neck of the receiver with the left hand at the moment the cork holding the tubes is removed with the right. When the gas is to be kept for any length of time, of course a stopper will be required.

“The apparatus is especially valuable for chlorine, as hot water can be readily used with it; and it is well adapted for class experiments in schools, as a receiver full of oxygen can be made and used in five minutes, and the whole process be seen by the pupils.”

JAPANNED METAL WATER TROUGH.

Figure 129 represents a very light and convenient pneumatic trough made of japanned tin-plate. It is adapted for experimenting with jars of sixty cubical inches and under. The trough is ten inches long, six inches and a half wide, and four inches deep. The clear water-way, *a*, measures ten inches by four inches. The shelf, *b*, is half-an-inch wide. The shelf, *c*, is one inch and a half wide. These shelves are made by bending a tin-plate into the form shown by the end of the trough, *e*. At the corner of the trough, *f*, there is a small tube which carries off the water that descends from jars when filling with gas, as soon as the level of the water in the trough arrives within half-an-inch of the edge. A separate tray, of the size of the cavity, *a*, is provided for that purpose under the side, *f*, of the trough. The shelf, *d*, is movable, and slides between the shelves *b* and *c*, the

whole length of the trough. A small box is made below the shelf, *d*, to catch the gas from the delivering-pipe, which is brought below it, and a small hole in the upper part of the box permits the gas to pass into jars placed above it. In operating with this trough, you place it cross-wise on the table before you, with the end, *e*, to your right hand. The bottle in which you are preparing the gas that is to be collected, must be placed upon your left hand, with the delivering-tube dipping into the water-trough just low enough to go under the box soldered below the shelf, *d*. You then fill the glass jar with water, invert it, and place it upon the shelf, *d*, and adjust the latter over the mouth of the delivering-tube. When the jar is full, you remove it upon a small tray, and place it, if you wish to set the small tray at liberty, in the long tray which serves to catch the overflowing water from the trough. By this means the long tray is rendered equivalent to extra shelf-room in the trough. A trough of this pattern, twenty-one inches long, fifteen inches broad, and eleven inches deep, is sufficient for a lecturer who has a large audience. It is adapted for jars fourteen inches long and seven inches wide.

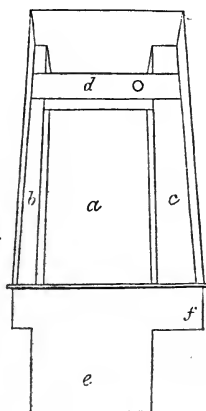

129.

Pneumatic Trough for experiments on small quantities of gases in glass tubes. — Figure 131 represents an earthenware pan about two inches deep and twelve inches in diameter. In the centre is a loose bee-hive shelf, figure 130, also of earthenware, about two inches in diameter, and one inch in height. This is a convenient apparatus for collecting gases in glass tubes.

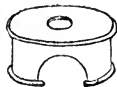

130.

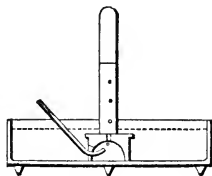

131.

TATE'S PNEUMATIC TROUGH.

Figures 132 and 133 represent a pneumatic trough designed by Mr. Thomas Tate, and which is constructed in such a manner as to serve the double purpose of a pneumatic trough and a hydraulic blow-pipe suitable for glass-blowing. Figure 132 represents it as arranged for a pneumatic trough. It is sixteen inches long, twelve inches wide, and fourteen inches deep outside. The well will fill jars of twelve inches high by six inches wide. *a* is the fixed shelf of the trough, *b* a movable shelf, which must be lifted when a large jar is to be filled, *c* is the gas-

delivery tube coming from the gas-generator. The tubes *d* and *e* belong to the blow-pipe, the arrangement of which is represented by

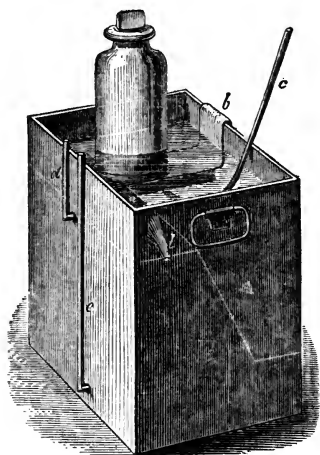

132.

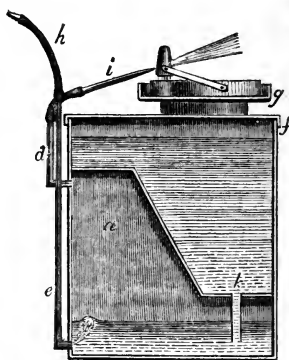

133.

figure 133. *f* is a cover which closes the trough and supports the glass-blower's lamp, *g*. Air is blown into this blow-pipe, through the pipe *e*, by the mouth applied to the mouth-piece, *h*. The air is forced out towards the lamp through the pipe *d* and the glass jet, *i*. The water-pressure which expels the gas acts through the pipe, *k*. Though the water of the trough has no great height for pressure, yet the quantity so far compensates for want of head that the pressure is sufficient for most small operations in glass-blowing. *l*, in figure 132, is an overflow-pipe, which carries off the water that descends from the jar in proportion as the jar fills with gas. The use of this overflow-pipe is to prevent the water rising so high in the trough as to cause the jar to swim and fall over. Such an overflow-pipe should be put to all pneumatic troughs of small size.

GENERAL OBSERVATIONS REGARDING THE MANAGEMENT OF GASES.

The tube which is to convey the gas from the vessel in which it is generated to the gas-holder, or receiver, must be of sufficient diameter to allow the gas to pass as rapidly as it is produced, otherwise an explosion may occur in the generating-vessel. A very sound and carefully-bored cork should be used to connect the tube with the gas-bottle, or retort. When the orifice of the latter is above an inch in diameter, it is advisable to cement a flat piece of wood to the top of the cork, as it is

rare to find so large a cork air-tight. The point of the tube that enters the gas-bottle should be cut aslant, to let drops of liquid fall readily back. The other point should be turned a little upwards, to facilitate the delivery of the gas.

When the conducting-tube is fixed into the bottle, apply your mouth to the open end of the tube, and *suck* strongly: you will thus ascertain whether or not the joinings of the apparatus are completely air-tight, and if not, they must be made so. You will, of course, make this trial when the bottle is empty, and not while gas is being generated within it. You will also take care to see previously that the end of the tube is quite smooth, and has no sharp points or edges capable of cutting the lips or the tongue. If the joinings are not air-tight, they may sometimes be rendered so by applying a small quantity of a cement; but it is better to fit new and sound corks on the tubes.

For many purposes corks can be usefully replaced by vulcanised indian-rubber connectors made after the following patterns:—

The wide part of the cap is put over the neck of the bottle, and the gas-tube is fixed in the narrow pipe. These caps do not bear so much pressure as corks, but they are very handy for many common purposes.



134.



135.



136.



137.



138.



139.

The above figures represent gas-bottles fitted up with such caoutchouc caps. Figure 137 is a simple bottle for preparing such gases as require the aid of liquids. Figure 139 represents such a bottle with an acid funnel, and a wash-bottle for freeing the gas from impurities. It also represents the sort of apparatus that is to be employed when a gas is to be absorbed by a liquid. Figure 138 is another form of Woulff's bottle fitted up for passing gases through liquids, having in the middle

a safety-tube. Before the invention of caoutchouc-tubes and of cork-borers it might have taken a whole day to fit up such a bottle by means of cork and cement, while it can now be effectively done in less than five minutes.

The materials put into a bottle to produce a gas must never exceed in bulk the third or fourth part of the capacity of the bottle, otherwise they are apt to boil over when the action comes to be powerful, and the disengagement of gas rapid. When the materials consist of a liquid and a fine powder, the liquid should be put into the vessel first, and the powder afterwards, and the two should be carefully mixed by shaking the vessel. You must take care not to respire an atmosphere contaminated by deleterious gases. Sulphuretted hydrogen gas is a particularly powerful poison, and it is fortunate that its noisome odour gives timely notice of its presence. Chlorine gas is exceedingly difficult to breathe, but it is not so injurious as the preceding. Arseniuretted hydrogen gas is very deadly; a celebrated German chemist was killed by smelling it. Carbonic acid gas occasions suffocation if mixed with the air in large proportions. Experiments with deleterious gases ought not to be made in a close apartment, but either under a large chimney or in the open air. The first portion of gas, of whatever kind it may be, evolved from the vessel in which it is formed, is always contaminated with the common air with which the vessel was filled at the beginning of the operation. A quantity of the first gas received, equal in bulk to twice the capacity of the generating vessel, must, therefore, in order to avoid accidents and failures, be thrown away. The measuring of this quantity is effected by collecting it in glass jars over water.

The moment requires to be watched when gas ceases to come over from a glass vessel. The gas-leading tube must then be immediately taken from the water-trough, otherwise the cold water is liable to go back into the hot bottle, or retort, and break it.

In certain cases care must be taken not to mix gases with atmospheric air. When a gas-delivery pipe is attached to a gas-holder, the first gas which it delivers will be contaminated by atmospheric air, unless the atmospheric air be first displaced by filling the tube with water.

EXPERIMENTAL ILLUSTRATIONS OF THE PROPERTIES OF OXYGEN GAS.

Oxygen Gas supports Combustion.—*Process 1.*—Fill a bottle with oxygen gas, and provide a small taper fixed at the end of a wire passed through a cork, as shown in the figure. Light the taper, and plunge it into the gas, taking care to put the light in the middle of the vessel, and not near its sides, otherwise the heat will crack the glass. The flame of the taper will become extremely bright while it is burning in the oxygen gas.

Process 2.—Fill a small tube with oxygen gas, and hold in it a lighted splinter of wood.

Process 3.—If the light of a taper be blown out, and the taper be let down into a glass of this gas, while the snuff (which should be a thick one) remains red hot, it instantly rekindles, with a slight explosion. When the taper is relighted, it continues to burn, as in the preceding case, with a rapidity, a brilliancy of flame, and an evolution of light truly wonderful.

This experiment can be more conveniently performed in a deflagrating jar with a wide mouth, such as is represented by figures 110 and 115, page 168.

Results of Combustion.—During combustion in oxygen gas the volume of the gas often decreases, and, if the combustion continues long enough, the gas wholly disappears. This is owing to a combination which takes place between the oxygen of the oxygen gas, and the body that is burnt in the oxygen gas.

Sometimes the product of such combustion is a gaseous body, and sometimes a solid. Thus, sulphur produces sulphurous acid gas, and carbon produces carbonic acid gas;—but phosphorus produces phosphoric acid, which is deposited in a *solid* state, and a vacuum is produced in the vessel wherein the combination of the two elements takes place.

During combustion great heat and light are often produced, but combustion can occur without any sensible production of either light or heat.

When combustion takes place in *common air*, the same phenomena occur, but less rapidly, and to a less extent. By burning substances in a given portion of common air, the bulk of that portion of air is diminished one-fifth, and the remaining quantity will support neither combustion nor animal life. The portion of air thus abstracted has been proved to be oxygen, and the air remaining is nitrogen. And by mixing nitrogen gas and oxygen gas in the above-mentioned proportions, a compound is obtained which possesses precisely the same properties as common air. Thus, therefore, the composition, and the proportions of the constituents, of atmospheric air, is proved both by analysis and synthesis.

The grand uses of air being to support life and combustion, and its pure part being abstracted thereby, a continual supply becomes necessary wherever those processes are carried on. This shows us how important it is to renew the fresh air of the rooms we live in, in order that



140.

141.

breathing, and the burning of fires and candles, may be readily carried on.

The subject of *combustion* will be more fully investigated in the article on carbon.

CHARCOAL BURNS BRILLIANTLY IN OXYGEN GAS, AND PRODUCES CARBONIC ACID GAS.—*Process 1.*—Fill a bottle with oxygen gas, or else use a deflagrating jar, which is open at bottom and has a wide mouth that can be closed by a stopper. When full of gas, this jar should stand in a tray containing water. Then put a piece of red-hot charcoal into a *deflagrating spoon*, and plunge it into the gas; allowing the instrument to be sustained in its place by the cork, or a flat piece of tin plate, *a*, which is laid upon (not fastened into) the neck of the bottle. The ignited charcoal must not be allowed to go near the sides of the vessel or the glass will crack. As soon as the red-hot charcoal comes into contact with the gas, it begins to burn very vividly, its combustion proceeds with great splendour, and brilliant scintillating sparks are thrown out in all directions.

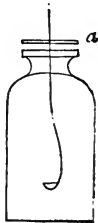

142.

When the combustion is at an end, it will be found that the oxygen gas has been converted into carbonic acid gas. The reason that the cork to which the spoon is attached must not be screwed tight into the neck of the bottle, is that the gas, upon being heated, expands, and would burst the bottle were it closely fastened up.

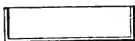

143.

The *deflagrating spoon* is made of iron, the bowl about as big as a shilling, with a long wire handle, which can be passed through a cork, contained in a short metal cylinder, soldered to a flat plate of metal, serving to close the mouth of a jar containing the gas submitted to trial.



144.



145.

The deflagrating spoon may also be made of brass, to this pattern, the handle passing through a stuffing-box.

Process 2.—The preceding experiment may be performed on a smaller scale, by employing a jar that holds less gas, and using a wire, with a bit of charcoal fastened to the end of it. In this case, beautiful sparks will be thrown out, as before. The charcoal should be made from a piece of bark such as oak-bark, in order that it may burn with sparks.

Process 3.—The combustion of charcoal in oxygen gas can be exhibited in a very striking manner as follows:—A quantity of dry saltpetre, about 3 ounces, is put into a florence flask or similar thin hard glass vessel, and is heated over the argand spirit-lamp *g*, till the salt is in full fusion. The pan *p*, filled with water is then put below the flask. You have ready (previously prepared) about half an ounce of charcoal in fine powder, and perfectly dry. The lamp is turned round from under the flask, and the charcoal dust is immediately poured through a dry wide-necked funnel, into the flask, where it produces a splendid deflagration. If the flask breaks, the contents fall into the water and do no harm.

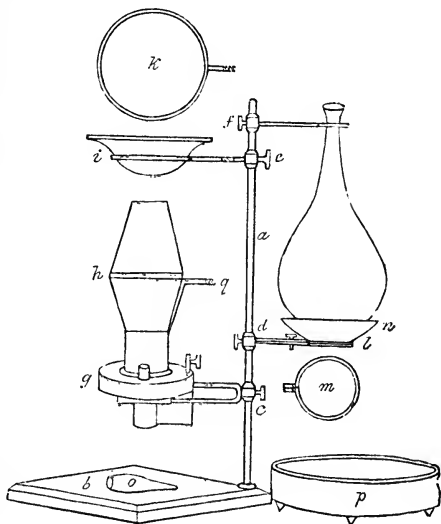

146.

Process 4.—The same experiment may be performed very easily with the help of the little apparatus figured in the margin. It consists of a thin hard Bohemian glass tube, 3 inches long and nearly an inch wide. It is supported by a narrow crook of tin-plate *c*, fixed by means of a cork *a*, into the sliding socket of a tube-holder *b*. As much nitrate of potash is used as fills about half an inch of the tube when melted. The heat of a small spirit-lamp is sufficient for this quantity. The dry charcoal powder is inserted by means of a slip of iron *d*. The lamp may be moved aside. The deflagration is very brilliant even with this small quantity of saltpetre.

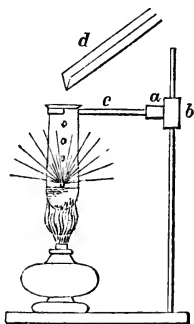

147.

Theory :—

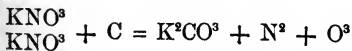

Two atoms of nitrate of potash = KNO^3 are decomposed because the

resulting carbonate of potash is bibasic = KKCO^3 or $\text{KO}, \text{KO}, \text{CO}$. See the explanation of this point in the article on the carbonates. * The nitrogen and part of the oxygen is set free. If charcoal is in excess, part of O^3 becomes CO^2 .

In this simple manner, not only charcoal, but sulphur, phosphorus, and a spiral of iron wire may be burnt in oxygen gas, forming very brilliant experiments.

Examination of the Gas produced by Burning Charcoal in Oxygen Gas.—When charcoal has been burnt in oxygen gas, as described at page 182, it is proper to show that the gas is changed in properties. Remove the jar to the pneumatic trough, and transfer the gas into several small jars of this sort, sliding each off into a small tray.



148.

Invert one of these jars, and put into it a slip of moistened blue litmus paper, which will immediately turn red.

Into a second, pour a little clear lime-water, and shake it with the gas; it will immediately become turbid.

Into a third, put a lighted candle. The flame will immediately be extinguished.

These results are such as do not occur with oxygen gas, and such as always occur with carbonic acid gas, into which the oxygen has been changed by combination with carbon. Thus $\text{C} + \text{OO} = \text{CO}^2$.

SULPHUR BURNS BEAUTIFULLY IN OXYGEN GAS, AND PRODUCES SULPHUROUS ACID.—*Process 1.*—A piece of sulphur, the size of a pea



149.

is put into the iron spoon, set fire to by a candle and blowpipe, and plunged into the same jar, and in the same manner as directed for performing the experiment with charcoal. See page 182. The sulphur burns with a beautiful violet-coloured scintillating flame, and the jar becomes filled with sulphurous acid gas. If superfluous oxygen and a little water be present, the latter is converted into very weak oil of vitriol.

Process 2.—The apparatus described in Process 2, page 183, may also be used to show the combustion of sulphur, which may be added to the melted nitre in powder or in very small bits.

Theory:— $\text{KNO}^3 + \text{S}^2 = \text{KSO}^2 + \text{N} + \text{SO}$. That is to say, the products of the deflagration are sulphate of potash, free nitrogen gas, and sulphurous acid gas.

SPLENDID COMBUSTION OF PHOSPHORUS IN OXYGEN GAS, AND PRODUCTION OF PHOSPHORIC ACID.—*Process 1.*—The light of phosphorus in combustion in oxygen gas, is one of the most splendid that can be produced. Place a stick of phosphorus, about half an inch long, in a little hemispherical copper cup, raised by means of a wire-stand about six inches

above the surface of water contained in a tray. Fill a large globular receiver with oxygen gas, and then press over the mouth of the receiver, after lifting it from the shelf of the pneumatic trough, a circular piece of pasteboard, rather exceeding its diameter. Bring the receiver filled with oxygen gas immediately over the phosphorus; let the latter be ignited by an assistant, then remove the pasteboard, and bring down the receiver so as to cover the phosphorus, and immerse it in an atmosphere of oxygen. Several holes should be pierced in the foot that supports the cup, through which the gas expanded by heat may escape. When the oxygen gas is pure, it is sufficient to fill only *half* the receiver. Then, when the phosphorus is ready, the receiver is lifted vertically from the water and put over the phosphorus, without paying regard to the common air that enters, which does no harm. The inflammation of the phosphorus is so extremely brilliant, that it is almost impossible for the eyes to bear the light. The white odorous compound produced by the combustion is anhydrous phosphoric acid, which settles on the sides of the receiver in white flakes, and finally dissolves in the water, with which it combines, and produces a solution of hydrated phosphoric acid:

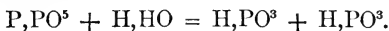

Figures 150 and 151 represent the apparatus necessary for this important and brilliant experiment. Figure 150 represents the cast-

iron table and phosphorus cup. Figure 151 shows the whole apparatus in position: *a* is the glass globe; *b*, the phosphorus cup; *c*, the iron table; *d*, a stoneware pan filled with water to about a quarter of an inch above the surface of the table *c*. The globe *a*, should be at least 8 inches in dia-

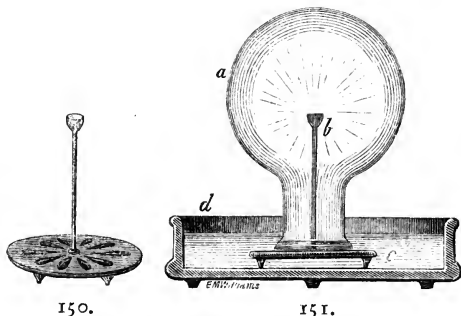

meter, the neck of it about 3 inches in length and the same in diameter. For a large theatre, the globe may be 12 inches in diameter. It should be strongly welded, and ground flat at the mouth, that it may stand steadily. The pan must be 12 inches in diameter, and not more than two inches deep. When these proportions are observed, the apparatus is easy to handle, and the experimenter incurs no risk of failure or of breaking the globe. If the neck of the globe is too short to be readily grasped by the hand, or if the water-pan is deeper than two

inches, it is better to lift the globe by applying one hand to each side of the body.

Process 2.—When a small quantity of phosphorus and gas is employed, the experiment may be performed in the way exhibited by figure 152, where *a* is a cylindrical receiver containing oxygen, and *d* a support for the phosphorus, standing in water.

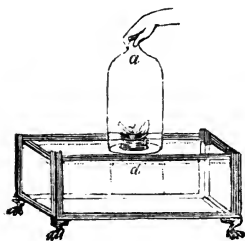

152.

Process 3.—The foregoing experiment may also be performed by fastening a bit (of the size of half a pea) of phosphorus to a wire, or putting it in the iron spoon, and then immersing it in a bottle of oxygen gas.

Process 4.—Phosphorus in small bits not much larger than pins' heads, may be dropped into a tube containing fused nitre. See Process 4, page 183.

Caution.—The student is particularly cautioned against using larger pieces of phosphorus than those directed, because phosphorus produces very painful burns, and when it is in a liquid and burning condition it is liable to be scattered about by any careless movement. The pieces should be rapidly but thoroughly dried, but without being rubbed, on blotting-paper. They should always be smaller than the spoon in which they are to be burnt—never so large as to project over its sides—and they should be inflamed by being heated on the surface with a hot wire, and not by holding the spoon over a flame.

IRON MAY BE BURNED IN OXYGEN GAS: THE COMBUSTION IS ATTENDED BY A BRILLIANT LIGHT, AND THE PRODUCT IS A METALLIC OXIDE.—



153.

Prepare a bottle of oxygen gas and a wire as described below. Light the inflammable matter at the bottom of the wire, and plunge it into the bottle, suspending the whole by the cork. The flame will be instantly communicated to the wire, which will continue to burn with an appearance inconceivably brilliant and striking: proceeding with a meteor-like body, in a spiral form, and throwing out beautiful sparks in all directions.

These sparks, upon being examined when cold, are found to be very different from the iron of which they have been formed.—They are brittle and destitute of metallic lustre. The weight of the drops, too, is greater than that of the metal made use of; so that, in burning, something must have been added to them: this something is oxygen. The term applied to this compound is *oxide of iron*, or iron and oxygen. When the drops fly off in their fused state, they are so hot, that unless the bottom of the bottle be covered an inch or two with sand or water, they are apt to crack it.

The marginal figure represents a *spiral iron wire*, with a cork on its

upper part that fits the neck of a gas-bottle. The kind of wire to be used is about 1-30th of an inch thick, and is called by the ironmongers *binding-wire*. In order to bring it into the spiral, or cork-screw shape, it is coiled lightly round a stick of one-third of an inch diameter, and then drawn off. Afterwards, the cork is fitted on, it is drawn out to a proper length, say three-fourths that of the bottle, and has a morsel of tinder, charcoal, or thread dipped in brimstone or turpentine, fixed upon its lower end. A more effective method of burning iron wire, when it can be procured very fine, is to twist several pieces of it together like the fibres of a cord. This makes a finer experiment, and is less likely to fail, because a single wire sometimes burns in the middle, and the lower half drops off, finishing the combustion untimely. When iron wire is burnt in a jar with an open bottom, such as fig. 145, the oxygen gas being pure, and the cork fitting tight into the neck of the jar, the gas disappears and the water rises to the top of the jar.



154.

A steel watch spring can be burnt in pure oxygen gas, exhibiting a very brilliant appearance. Steel wire gives a more brilliant light than iron wire.

The spiral of wire may be fastened to a hook and rod passing through a stuffing-box with a brass flange.

COMBUSTION OF ZINC, AND FORMATION OF OXIDE OF ZINC.—Substitute, for phosphorus in the experiment above described, a small ball formed of turnings of zinc, in which about a grain of phosphorus is enclosed. Set fire to the phosphorus, and cover it expeditiously with the jar of oxygen. The zinc will be inflamed, and burn with a beautiful white light.

CAOUTCHOUC, CAMPHOR, and many other combustible substances burn in oxygen gas with great energy.

PROOF THAT METALS ARE INCREASED IN WEIGHT BY COMBINING WITH OXYGEN.—Coil up a drachm of very slender iron wire, put it into the bowl of a tobacco-pipe, and place it in a clear fire. Have ready a bladder filled with oxygen gas. When the iron in the pipe is red hot, force from the bladder through the pipe a stream of oxygen gas. The iron will burn very rapidly, and, by combining with the oxygen, be converted into oxide of iron. If the bowl of the pipe is kept free from dust, the iron will be found to have increased considerably in weight by its oxidation.

The experiment last cited can be made in a more accurate manner as follows:—Letter *b* represents a bent tube of hard German glass, in size 10 inches long by $\frac{3}{4}$ inch diameter. It is supposed to be half full of oxygen gas, and to be standing over mercury in the trough *a*. By means of tongs that have a receiver consisting of two small hemispheres, *a, a*, that fit close together, a weighed piece of metal, such as Arsenic

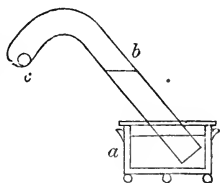

155.

or Potassium, is put through the mercury and lodged in the upper bent part of the tube, *c*, where it comes into contact with the oxygen gas.



156.

Heat is then applied to the metal externally, by means of a spirit-lamp, upon which the oxygen is absorbed and the mercury rises in the tube. The amount of absorption can be ascertained from a graduated scale engraved on the tube.

USE OF PEPYS'S GAS-HOLDER AS A BLOWPIPE.

The oxygen gas is compressed in the gas-holder, by water poured into the trough, or when greater force is desired, by water poured into the long funnel described at page 175. The gas then escapes with

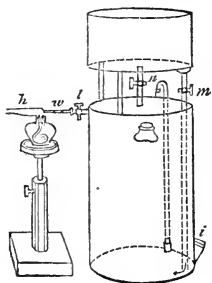

157.

velocity through the horizontal stop-cock marked *g* in the figure at page 175, and *l* in the present figure. Inflamed bodies, such as are referred to in the preceding experiments, held against this jet of gas, burn with vigour. Even a steel watch-spring can be burnt thus, the combustion being commenced by first passing the oxygen gas through the flame of a spirit-lamp, which is afterwards removed. A brass or platinum blowpipe jet with a fine orifice, *w*, is screwed upon the cock *l*. The gas is forced through the flame of a spirit-lamp, or into a hydrogen gas flame (the philosophical candle), and produces a blowpipe jet, *h*, of intense power. Platinum, and many other substances commonly considered infusible, can be melted in this jet.

Blowpipe with Gas-Bag.—A bag of waterproof cloth, figure 158, can be conveniently used as an oxygen blowpipe. The bag is filled with

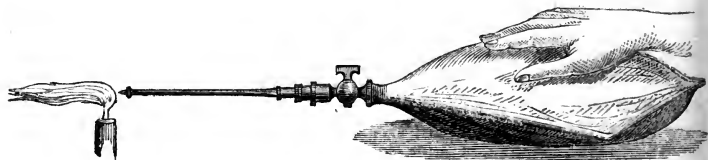

158.

gas by screwing the stop-cock to the gas-cock of a gas-holder, or to the gas jar, figure 120. When it is filled a jet is attached. Such a bag can either be squeezed by the hand or placed under the arm, and the jet be easily presented in any required direction. This, observe, relates to

oxygen gas, and not to oxyhydrogen gas; for experiments with which this apparatus could not be used in such a manner without imminent danger.

When a cheap apparatus of this description is required, the neck of a broken flask may be cut off and tied into the neck of a good bladder, softened with glycerine. To the glass neck two corks should be fitted; one of these should be perforated by a piece of glass tube, having a connector to adapt it to the gas-delivery tube; the other should have a jet-pipe formed either of brass or hard glass. The mouth of the jet-pipe can be closed for a time with a lump of wax. With the use of the first cork the bladder is filled with gas, and the corks are then exchanged; after which the bladder and jet can be used as a blow-pipe.

MITSCHERLICH'S ETHER-LAMP.

This apparatus consists of a glass spirit-lamp, in which sulphuric ether can be burnt instead of alcohol, and in which a contrivance is made for forcing a current of oxygen gas into the middle of the flame.

See figure 159. *A* is the spirit-lamp, *b* a cork adapted to a hole drilled in the bottom of the lamp, *a a* is a bent tube for bringing oxygen gas from a gas-holder. This supply-pipe ends in a blowpipe jet at *c*. *B* is a wooden foot. *d* is a tube to lead away from the flame, the ether-gas which is formed when the lamp becomes heated. The wick used for this lamp should be larger than for an ordinary spirit-lamp. When this lamp is lighted, and the oxygen gas set on under pressure, the flame becomes very small, and gives little light, but it has such intense heating power as to be able to melt both platinum and quartz. The tube that holds the wick should fit tight into the neck of the lamp, otherwise atmospheric air enters and forms an explosive mixture with the ether-gas. It is, however, difficult to prevent slight explosions with this lamp, but if care is taken they are not dangerous.

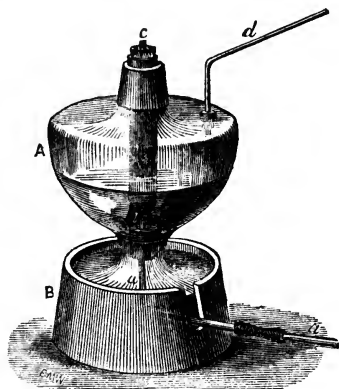

159.

The following little apparatus, which is easy of construction, produces also a powerful heat. *a a*, is a glass tube about three inches long and one inch in diameter; *b*, a cork, through which passes a narrow metallic-pipe, *c c*, having a blowpipe orifice at the upper end, and

adapted below, by means of the cork, *d*, to a gas-holder or other vessel containing oxygen gas. *e*, a stoneware or metal wick-holder, such as forms part of a small spirit-lamp. The wick is of asbestos, and the lamp is to be filled with sulphuric ether. The point of the pipe *c* must be close to the surface of the asbestos wick.

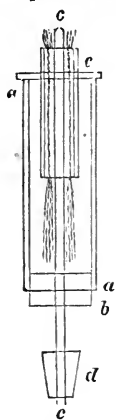

160.

Distinguishing Test for Oxygen Gas.—Half fill a jar with oxygen gas over water, and pass up into it, by means of a second jar, some nitric oxide gas. When these two colourless and permanent gases come into contact they produce a dark orange red coloured vapour, which is soon absorbed by the water of the jar. Only oxygen gas, and gaseous mixtures containing oxygen, act thus with nitric oxide gas.

EXAMINATION OF THE COMPOUNDS PRODUCED BY THE COMBUSTION OF METALS, METALLOIDS, &c., IN OXYGEN GAS.—I have, at page 184, recommended that the gas produced by burning charcoal in oxygen gas, be subjected to certain experiments to prove the acquisition of new properties. In like manner may the products of the combustion of other substances, whether gaseous, liquid, or solid, also have their properties developed by the action of suitable tests. It will then be found, that the products of the combustion of the metalloids when dissolved in water are acid, and those of the combustion of the metals are either alkaline or neutral, according to the special nature of the metals that are submitted to trial in each combustion.

2. HYDROGEN.

Symbol, H; Equivalent, 1; Specific Gravity of Gas, 1; Atomic Measure when isolated, 1; Atomic Measure when acting as a radical in salts, 1; Condensing action on the Atomic Measure of other Radicals, 0.

Occurrence.—It exists in water, nine parts by weight of which contain one part of hydrogen. It is also an essential constituent of all animal and vegetable substances. This element is therefore of immense importance as a constituent of the material world. See page 9.

Properties.—At the ordinary temperature it is a gas, colourless, tasteless, inodorous, insoluble in water, and without action on test-papers. It is easily combustible, and if inflamed at the mouth of a pipe in oxygen or air, it gives a flame of intense heat, but scarcely any light. If hydrogen gas and oxygen gas are mixed, and then inflamed, they burn with violent explosion. The gases disappear in the proportion of two volumes of hydrogen to one volume of oxygen. The product is water. Hydrogen gas is unfit for respiration, yet may be safely breathed once or twice if pure, and is said to give a shrillness to the voice. But it is difficult to procure hydrogen gas perfectly pure, and fatal to breathe it when containing certain impurities.

Hydrogen gas is the lightest known body, its specific gravity bearing to that of air the relation of 1 to 14.47, and to that of oxygen the relation of 1 to 16. When the specific gravity of air is fixed at 1.000, that of hydrogen becomes 0.069108, and was found experimentally by Regnault to be 0.06927. See page 140. It seems to me to be absurd to make the density of atmospheric air the unit or standard of gaseous densities, because it gives a very uneven number, for every gas without exception; whereas, by making hydrogen the standard of comparison, as well for density of gas as for weight of equivalent, great regularity is obtained, and all gaseous densities are expressed in simple numbers directly referring both to their chemical equivalents, and their atomic measures. Why do chemists plague themselves and puzzle their students by adopting for the specific gravities of gases, a standard of comparison which is ridiculously inconvenient? A century ago, when chemists first began to discriminate gases, it was natural enough to compare their properties, both chemical and physical, with those of atmospheric air. But in the present state of gaseous chemistry, the retention of such a standard is a barbarism.

The weight of a cubic inch of hydrogen gas is 0.021379 grain. 46.775 cubic inches = 1 grain. Barometer, 30 inches. Thermometer, 60° F. Its atomic measure is one volume. Its atomic weight = 1.

I refer the reader to the suggestion offered at page 141, respecting the graduation of gas-measures in such a manner that *volume* should in all cases readily intimate *weight*. There is no doubt that by and by, when chemists have resigned some of their present prejudices in favour of established practices, for no other reason than that they *are* established, this method will be universally adopted.

PREPARATION OF HYDROGEN GAS.

NOTE.—*The reader is supposed to be master of the information respecting the management of gases, which has been given in the article on Oxygen.*

a). Put into a tall test-glass a small quantity of diluted sulphuric acid, prepared by mixing one measure of oil of vitriol with about eight measures of water. Then dip into the acid a long slip of thin sheet zinc, or drop in a few pieces of granulated zinc. Effervescence (p. 56) will immediately commence about the metal, which begins to dissolve, and an immense number of bubbles of air will rise through the liquid and escape at its surface. These bubbles are hydrogen gas.



161.

b). Clean iron, in the form of nails, wire, turnings, filings, borings, &c., put into the same acid, also disengages hydrogen gas; but the gas prepared with this metal is commonly more impure than that prepared with zinc, and has a disagreeable smell, which is owing to impurities contained in the iron.

c). Diluted muriatic acid may be used with the same success as diluted sulphuric acid.

d). When the gas is to be collected for experiments, it may be prepared in a gas-bottle of the form represented in the margin. The capacity of the bottle may be from one ounce to forty ounces, according to the quantity of gas that may be desired. Such sizes as eight ounces and sixteen ounces are generally used for preparing small quantities of gas. The bottle is most handy when made with a flat bottom. The mouth should be very round and rather less than an inch in diameter, because it is difficult to fit it with an air-tight cork if wider. The cork should have the full length of a wine-bottle cork, and the part that projects beyond the bottle should be coated with strong varnish to fill up the pores. The bent glass gas-leading tube should be passed

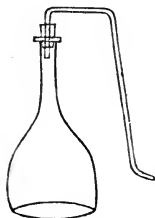

162.

through a hole in the cork carefully bored to fit the tube by means of a brass cork borer. The length and bend of this tube should be such that the gas may be conveniently passed from the bottle into the

gas-holder, page 175, or the pneumatic trough, page 177, &c. The bore of the tube must be large enough to permit the gas to escape as rapidly as it is produced. Tubes of such sections as figures 163 and 164 are convenient. If the tube be very narrow, and too much or too strong acid be taken, the pressure of the gas may burst the bottle. The substance of the glass should never be so thin as is represented by figure 165, otherwise the tubes are too fragile, and moreover it is more difficult to bend thin tubes than thick tubes into suitable forms.



165.

Figure 166 represents a gas-bottle of very useful form, fitted with an indian-rubber cap and tube, instead of a perforated cork.

The zinc being put into the gas-bottle, and a little water added, say, to about the capacity of one-fourth of the bottle, strong sulphuric acid may then be added; but it is better to use an acid already diluted. Sulphuric acid of 50°, or containing 50 test atoms of HSO² per decigallon (see the subsequent article on Sulphuric Acid) gives a rapid current of gas; but acid of 25° is generally to be preferred.



166.

e). For the sake of greater convenience, and in order to prevent accidents, the gas-bottle is often arranged in another manner. The neck is chosen wider, namely, about an inch and a quarter diameter, and the cork is twice perforated. If a sound cork, both long

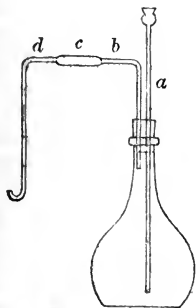

167.

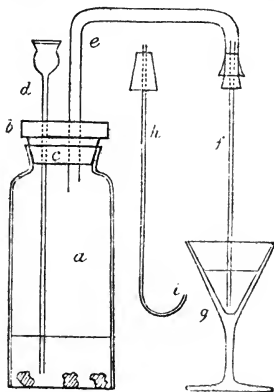

168.

enough and wide enough, can be got, you may be thankful; for a good cork is a treasure to a man who has to prepare a gas-bottle. But it commonly happens that corks more than an inch in diameter are too short to be useful for bottles that require to be frequently uncorked. It is necessary, therefore, to lengthen them, as represented in figure 168, by cementing to the upper end a disc of plane-tree wood, half an inch thick, a little wider than the cork, and milled on the edge. The wood and cement entirely close the pores of the cork, and the wood serves as a handle for the system of tubes fixed within it. The wood must, of course, be bored with two holes, corresponding with the holes in the cork, and which holes are prepared to suit the glass tubes that are intended to be fixed in them. These tubes are shown in figure 167, where *a* represents a glass funnel with a neck from fifteen to twenty-four inches long, *b* a glass tube bent in the form of letter γ , *d* a gas-delivery tube of the form already described, and *c* a flexible tube of caoutchouc used to connect *b* to *d*, so as to leave *d* a little movable. The wooden top is not shown in this figure, but is represented by *b* in figure 168.

Figure 169 shows a different form of bottle, which requires to be made of hard German glass with a thin flat bottom. Flint glass bottles with thick bottoms, and if flat with punty marks, are unfit for gas-bottles. They answer indeed for hydrogen gas, but not for the preparation of other gases that require the help of heat.

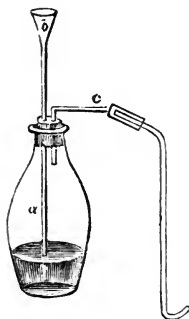

169.

In figures 167 and 169 the acid-funnel, *a*, is represented of considerable length, whereas in figure 168 a very short acid-funnel is shown. The reason is, that the bottle with the short funnel is intended to prepare gases for *testing* purposes (see Sulphuretted Hydrogen), where the pressure exercised by the liquor upon the end of the delivery-tube is very small: whereas, when the delivery-tube passes into the water of the pneumatic trough, a considerable portion of it is sometimes submerged, and the liquor in

the gas-bottle rises in the acid-funnel a length equal to the dip of the delivery-tube in the water of the trough. If, therefore, the acid-funnel is made too short, the acid of the bottle may overflow by the funnel, in consequence of the joint pressure of the generating-gas and of the water of the trough.

To prepare Hydrogen Gas with a gas-bottle fitted with an acid funnel, proceed as follows:—Put into the bottle some metallic zinc, in the state of granulated zinc, turnings of zinc, or slips of rolled zinc. Fix the cork with its system of tubes in the neck of the bottle; pour a little water through the funnel, so as to fill about one-third part of the bottle, or, at any rate, to cover the lower end of the long funnel, and then add

strong oil of vitriol in small quantities at a time. The disengagement of gas commences immediately, and when it slackens, may be invigorated by adding a little more acid. It is thus very easy to regulate the production of the gas, causing it to be either slow or rapid, by the proper management of the acid. The first gas collected, to the extent of twice the contents of the bottle, must be rejected as impure.

Theory of the Production of Hydrogen Gas :—

When Sulphuric acid is used,		When Muriatic acid is used,
$\text{HSO}^2 + \text{Zn} = \text{ZnSO}^2 + \text{H}.$		$\text{HCl} + \text{Zn} = \text{ZnCl} + \text{H}.$

That is to say, the basic radical hydrogen of the acid is replaced by the basic radical zinc. The sulphate of hydrogen is changed into the sulphate of zinc, or the chloride of hydrogen into the chloride of zinc.

We sometimes find these remarks in books. "Hydrogen is always obtained by deoxidising water." "It is not easy to explain the fact of the ready decomposition of water by zinc, in the presence of an acid or other substance which can unite with the oxide so produced." The reason of the difficulty of explanation is, that the fact itself is disputable. There is no evidence that water is decomposed in this experiment. No excess of zinc can expel from any quantity of water more hydrogen than is furnished by the atomic quantity of hydrated sulphuric acid that is neutralised by the dissolved zinc. HSO^2 gives H, and no more. On the other hand, Zn gives H, and no more, however great the excess of acid and water with which it may be placed in contact. Therefore, none of the hydrogen comes from deoxidised water, at least, according to the ordinary meaning of that term. It is all derived from the oil of vitriol. It is, however, the general fashion to say that oil of vitriol contains an atom of water, and this opinion is expressed in the common symbol HO,SO^3 , yet even that is not a certainty, for oil of vitriol may not only be represented as HO,SO^3 , but as $\text{H} + \text{SO}^4$, or as $\text{HO}^2 + \text{SO}^2$, in which cases the oxygen and hydrogen are not present as water, but in a different state of combination. Hence the declaration, that "hydrogen is always obtained by deoxidising water," is not the expression of a mere matter of fact, but of a preconceived theory, which may possibly be true, but possibly may be erroneous. It is, indeed, true that the mixture $\text{HSO}^2 + \text{Zn}$, without additional water, does not give off hydrogen gas, but the reason is that the zinc becomes instantly coated with sulphate of zinc, which is insoluble in strong sulphuric acid. The use of the water is to dissolve the generated sulphate of zinc and expose continuously a clean surface of metal for the acid to act on. Instead of the explanation usually given of this experiment, namely, "that the acid assists the metal to decompose the water," it would be more exact to state, that *the water assists the metal to decompose the oil of vitriol*. In one respect, however, it is true that the hydrogen comes from deoxidised water, and this is, that the hydro-

gen contained in oil of vitriol is originally procured from water. But this ultimate truth is not what is commonly referred to.

f). *Preparation of Hydrogen Gas without an acid.*—Fill a small gas bottle with a solution of caustic potash of sp. gr. 1.3. Add fine zinc turnings and cast-iron borings. Apply a cork and gas-leading tube, fill the tube with the solution of potash, and insert the end of it under a gas jar filled with water, and inverted in a pneumatic trough. In a short time hydrogen gas is disengaged by the mixture, and when the current slackens it may be increased by applying a gentle heat to the gas bottle. The zinc dissolves, but not the iron. If the materials are pure and the liquids previously boiled to expel atmospheric air, very pure hydrogen gas may thus be prepared, with the utmost ease and in considerable quantities.

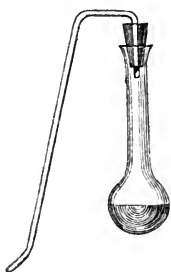

170.

Theory :— $\text{KHO} + \text{Zn} = \text{KZnO} + \text{H}$.

This experiment seems to me to confirm the arguments urged in the preceding article. The hydrogen produced is exactly equal in quantity to that contained in the decomposed portion of hydrate of potash. Never more. The water employed acts merely as a solvent, and is not concerned in the chemical changes that occur. The use of the iron is to form a galvanic circuit, to hasten the solution of the zinc. It is not essential to the decomposition, for zinc dissolves slowly in a solution of potash, when iron is absent.

Hydrogen gas is also disengaged when zinc and iron are put into solutions of caustic soda and caustic ammonia.

The two following are genuine examples of the liberation of hydrogen gas from water.

g.) Fill a glass test-tube, half an inch wide and four inches long with mercury, and invert it in a small porcelain cup containing mercury.



171.

Pass up a little water into the tube, and afterwards pass up a very small piece of metallic potassium or sodium. When the latter touches the water, it will be dissolved and a quantity of gas will be disengaged. Close the mouth of the gas tube with the thumb, lift and invert it and apply a lighted taper to its mouth, upon which you will perceive the gas to burn like hydrogen. Pour the water from which the potassium expelled the gas into a test-glass, and test it with litmus paper or the application of coloured vegetable solutions. See page 31. You

will find it to be alkaline. Thus, then, potassium disengages hydrogen from water, and converts the latter into a solution of hydrate of potash.

Theory :— $\text{HHO} + \text{K} = \text{KHO} + \text{H}$.

h). When clean iron wire is twisted up and put into a porcelain

tube *b*, traversing a furnace *a*, and is made red hot, and water is passed over it in the state of steam, the water is decomposed, the iron is oxidised, and hydrogen is set free.

Theory:—

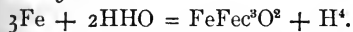

This is the intermediate oxide of iron which corresponds to the intermediate oxide of manganese referred to at page 164.

Figure 173 represents a complete apparatus for the performance of this experiment. The furnace is of an oblong form specially suited for heating tubes. I copy it from "Regnault's Chemistry."

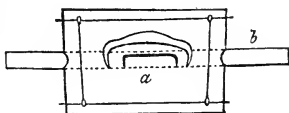

172.

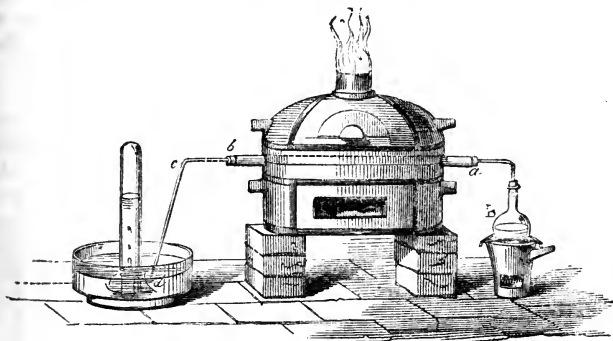

173.

The last two processes are introduced to show interesting facts, not as methods of preparing hydrogen gas.

To purify Hydrogen Gas.

a.) Connect the gas bottle with a second bottle containing a solution

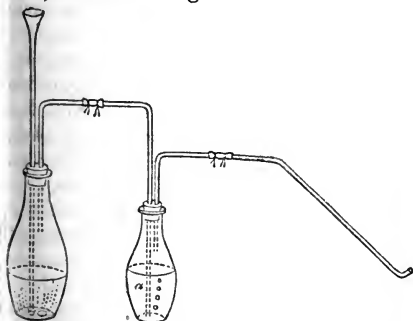

174.

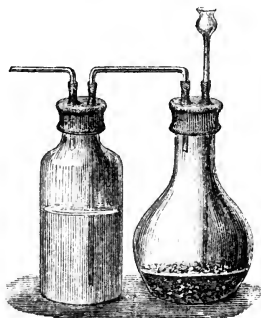

175.

of caustic potash, *a*, through which the gas is to be passed before it is collected at the pneumatic trough. The figures explain the details.

b.) Pass the gas through glass tubes filled with pumice-stone, moistened with a solution of caustic potash, and afterwards through a glass tube containing pumice-stone moistened with a solution of sulphate of silver. The gas is thus deprived of its odour. Glass tubes may be used of any of the following forms, figures 176 to 181. The V-shape and U-shape are commonly used when a large quantity of gas is to be purified. A great many other forms of apparatus for purifying gases will be seen on running over the following pages.



176.



177.

To dry Hydrogen Gas.

A glass tube is filled with lumps, the size of small nuts, of chloride of calcium that has been recently heated to redness in a crucible. This

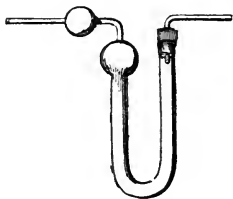

178.

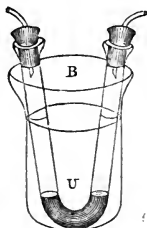

179.

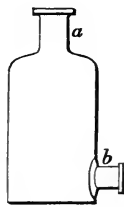

180.



181.

substance is extremely deliquescent, and therefore readily abstracts moisture from any wet gas that is brought into contact with it. One end of this drying tube must be connected with the vessel containing the wet gas, under pressure, and the other end of it with the apparatus into which the dry gas is to be driven. Care must be taken that the drying tube does not become choked.—Another method of drying gases is to pass them through a U-shaped or V-shaped tube, filled with knobs of pumice-stone, saturated with concentrated sulphuric acid, or through a small quantity of sulphuric acid put into the bend of the tube, as shown in the figures, or through a tube containing lumps of anhydrous phosphoric acid. This last is a very effective but expensive process. When large quantities of gas are to be dried, glass vessels of the form of figures 180 and 181 are sometimes employed. These are

filled with lumps of fused chloride of calcium. The gas is passed in by the lower tubulure and allowed to escape by the upper one. The solution of chloride of calcium, which gradually sinks to the bottom, can be poured out at the lower tubulure.

These *vessels* are used in purifying and drying all sorts of gases; but the *substances* requisite for the drying or purifying of different gases depend upon their natures. The purifying or drying substance must have the greatest possible power of absorbing the impurity that is to be separated, and the least possible action on the gas that is to be purified.

EXPERIMENTS ILLUSTRATING THE PROPERTIES OF HYDROGEN GAS.

Levity of Hydrogen Gas.—Fill a small jar with hydrogen gas, turn its mouth up and leave it open; in a short time the gas will have escaped, and the jar be filled with common air. Hydrogen gas can be put out of one vessel into another in the open air, by a species of inverted pouring.

A large light glass globe, fig. 114, is to be suspended, mouth downward, by a slight network of threads, to the end of a balance, and counterpoised. A flask containing hydrogen gas is to be opened and placed, mouth upwards, below the counterpoised globe. The air in the globe will descend and be replaced by hydrogen gas, and the weight of the globe will appear to be diminished, for it will rise.



182.

Combustible Nature of Hydrogen Gas.—Apply a light to the mouth of a small jar containing hydrogen gas, fig. 182. The gas will take fire and burn with a pale blue flame, that descends into the glass, and finally disappears.

At the lecture table, experiments of this kind may be performed with plain cylinders, 6 inches by 1½, or 9 or 12 inches by 2. For private experiments, small glass tubes may be used, such as 3 inches by 1 inch.

Hydrogen Gas does not support Combustion.—Into an inverted jar filled with hydrogen gas, introduce a wire bearing a lighted taper on its summit: the flame of the taper will be extinguished, but the gas will burn at the mouth of the jar.

MINIATURE BALLOONS. —A MODE OF ILLUSTRATING THE EXTREME LIGHTNESS OF HYDROGEN GAS.—Fill a bladder with hydrogen gas, in the manner directed at page 169, or 172, and adapt a common tobacco-pipe to the mouth of the bladder by means of a stop-cock. Some care is required in preparing a bladder for such experiments. The bladder should be well washed in warm water containing potash or soda, and the fat neck should be soaked in pretty strong potash water, and then scraped with a piece of wood. When cleaned thoroughly, a brass collar, fig. 185, must be tied firmly into its neck,



183.

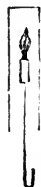

184.

and to this must be fitted a stop-cock, with two male screws, such as fig. 185. The tobacco-pipe may be made either of clay, fig. 187, or

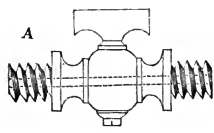

185.

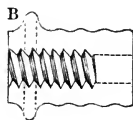

186.



187.



188.

brass, fig. 188. It must be cemented in the end of a connector, having at the other end, *b*, a screw adapted to one end of the stop-cock 185. The apparatus represented by fig. 158, may be used for this experiment, after removing the jet from it, and substituting the tobacco-pipe, fig. 188. Prepare a strong solution of soap (a lather such as children use to blow common soap bubbles with), dip the bowl of the pipe into it, and by compressing the bladder, after having opened the stop-cock, fill soap bubbles with the hydrogen gas. These, when shaken from the pipe, instead of falling downwards, like common bubbles, will rapidly ascend to the ceiling of the room. This experiment affords not only an illustration of the lightness of hydrogen gas, but also of the principles of *Aerostation*: for it is either with hydrogen gas, or with carburetted hydrogen gas, that air balloons are inflated.

If one of these soap bubbles be arrested in its flight by the application of a lighted paper, the hydrogen gas will take fire, and the bubble will burst with a vivid flash of light.

N.B.—Take care not to inflame the bubbles till they are detached from the pipe.

AIR BALLOONS.—A very pretty apparatus is sometimes to be had of the philosophical-instrument makers. It is a little balloon, in shape resembling a bladder, and about 4 or 5 inches in diameter. It is made of fish bladder, and is so extremely light that, when filled with hydrogen gas, and left free in the atmosphere, it *ascends*.

Balloons are also made of gold-beaters' skin. This material is thicker, but the balloons are more durable. When not less than 8 inches in diameter, they will ascend with pure and dry hydrogen gas. If of 10 or 12 inches diameter, they will ascend when filled with good dry coal gas. The mouths of such balloons must never be wetted, even with the-lips. When blown into by the mouth to ascertain their soundness, a glass tube should be used. They should be preserved in a tin case or a closed bottle, containing a piece of camphor, otherwise insects eat

holes in them. They cannot be conveniently filled with hydrogen gas direct from the bottle in which the gas is prepared. It is necessary first to collect the gas in a receiver or gas-holder, and then to transfer it. See page 169. In transferring the gas, it should be passed through a desiccating tube, containing chloride of calcium, in order to dry it and render it light. Before you begin to fill a balloon, you should have ready the whole quantity of gas necessary to fill it. If your mounted receiver, page 169, *a b c*, or page 204, *a c g*, is too small to hold the proper quantity, the remainder of the gas may be held ready in bottles or jars.

A balloon of this description, made of strong gold-beaters' skin, about 5 feet in diameter, and 7 feet in height, and of the capacity of 50 cubic feet, when filled with dry hydrogen gas, will carry up a weight of four pounds. The cost of such a balloon is five pounds.

I need scarcely inform my juvenile readers that round balloons of 8 or 10 inches diameter are sometimes painted so as, when filled with gas, to resemble boiled plum-puddings, and that these are occasionally served at the Christmas dinner-table under a dish-cover, which, on being removed, permits, to the astonishment of juvenile spectators, the apparent plum-pudding to ascend to the ceiling of the room, to be succeeded on the table by a plum-pudding of a less volatile character. †

THE PHILOSOPHICAL TAPER—AN ILLUSTRATION OF THE COMBUSTIBILITY OF HYDROGEN GAS.—Fit a narrow glass tube into the neck of a glass bottle, into which materials for producing hydrogen gas have previously been put. In a short time the gas will issue from the top of the tube. Let it escape till you think as much has issued as served in the beginning to fill the bottle, then apply to the top of the tube a lighted paper; upon this the gas will be inflamed, and will burn with a bluish-coloured jet, as long as it continues to be produced. This flame is scarcely visible in the day-time, but notwithstanding its dimness it is intensely hot. If a small piece of caustic lime or of chalk, with a fine point or sharp edge, is held in the flame, it soon produces a brilliant white light. The reason that a quantity of air must be suffered to escape has been explained. Hydrogen gas mixed with common air violently explodes when inflamed, so that particular care is requisite, in this experiment, to let all the common air escape. The glass jet must be made of hard (infusible) glass, pretty strong in substance, particularly near the point, otherwise it will melt and close up, and cause an explosion to occur. The orifice should be very small. The lower part of the tube, within the bottle, should be ground off aslant, that it may not become choked by drops of water. A little oil put on the surface of the liquor in the

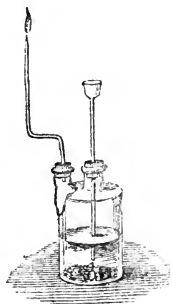

189.

bottle, causes the gas to pass off with more regularity. The most effectual way to prevent the occurrence of an explosion, in consequence of the fusion of the jet, is to use a bottle provided with a safety-funnel, as represented by figure 189.

Another mode of performing this Experiment, is by fixing a tube to a bladder or gas-bag filled with hydrogen gas,—when, by pressing the



190.

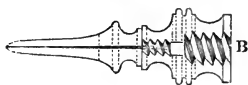

191.

bladder more or less, a very pretty jet, or stream of fire, either large or small, is easily produced. No danger need be apprehended, because the smallness of the hole in the end of the pipe prevents the flame from entering into the bladder.

These figures represent brass jets provided with screws to fix them to the stop-cocks of bladders, &c.

In the following figure the apparatus is shown complete.

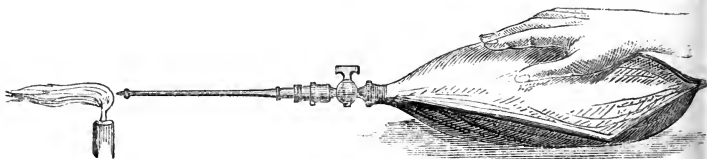

192.

MUSICAL SOUNDS PRODUCED BY THE COMBUSTION OF HYDROGEN GAS.—Take a glass tube, from 18 to 24 inches long, and from 1 to 2 inches wide, and open at both ends. See *b* in figure 193.

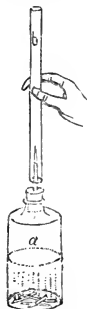

193.

Bring it down a few inches over the flame of the *philosophical taper*, and very strange but pleasing sounds, somewhat resembling those of an *Æolian harp*, will be immediately produced. By raising or depressing the tube, or by using tubes of different sizes, the intensity of the musical chord may be greatly varied. Two tubes may be so chosen as to produce a difference of an entire octave in the tone. The production of the sound is occasioned by the rushing of the air into the tube, to supply the vacuum repeatedly formed by the condensation of the oxygen of the air into water, as it combines with the burning hydrogen.

Hydrogen Gas has the power to give a peculiar shrillness to Sound.—Pure hydrogen gas can be safely breathed by man to the extent of two or three inspirations but not more, and when it has been breathed, it gives a peculiar shrillness to the human voice. It

is, however, difficult to prepare pure hydrogen gas, and when impure hydrogen is breathed, it readily causes death. A young chemist of Dublin performed the experiment of breathing hydrogen gas which had been prepared by means of commercial muriatic acid. He became very ill, and it was found on examination that the muriatic acid contained arsenic, in consequence of which the hydrogen gas which he had breathed contained that poisonous gas arseniuretted hydrogen. The unfortunate gentleman died after some days of severe illness. An experiment illustrating the action of hydrogen gas in modifying sound can be made as follows without danger. Fill a large bell-receiver with hydrogen gas, and place it in a tray in such a position that it can be readily fastened to a support proper to suspend it when the tray is removed. Strike the hammer upon the bell in the open air, and then recognise its peculiar tone. Then put hammer and bell into the hydrogen gas, and strike the bell again. The musical note will be entirely different from the former, and much shriller.

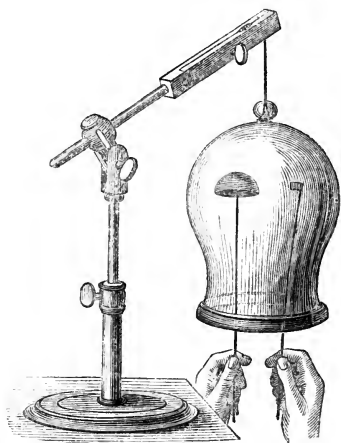

194.

The Hydrogen Lamp.—When hydrogen gas issues from a small orifice and strikes upon pure spongy platinum, held in the open air, it causes the platinum to become red hot. If the current of hydrogen gas continues, the red-hot platinum inflames it. The hydrogen lamp was contrived to apply this remarkable property of hydrogen gas to a useful purpose, and before the invention of lucifer matches, it was much employed as a ready means of procuring a light. This lamp is figured in the margin. *a* is a glass cylinder containing very dilute sulphuric acid, of about 30° or spec. grav. 1.1. *e* is a cylinder of zinc, the solution of which in the acid produces the hydrogen gas. The gas collects in the funnel *f*, which is cemented to the top *e*, and closed by the stop-cock *c*. The acid is gradually driven from the funnel into the cylinder, until the funnel is filled with gas. When the stop-cock *c* is opened, by pressing down the lever, the gas issues from the jet *b* and strikes upon the platinum held in the brass

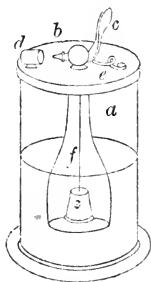

195.

collar *d*, immediately after which a flame appears between *d* and *b*, at which matches of paper may be lighted. Brimstone matches spoil the platinum. The platinum is fixed in the collar in the manner shown by the marginal figure. When the apparatus is first set up, the common air must be taken from the funnel, by covering the collar *d* with paper, and then opening the stop-cock *c*. The funnel is then allowed to fill with hydrogen gas, which is let off in the same

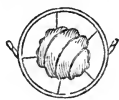

196.

manner, without being allowed to strike upon the platinum. This is repeated once or twice, after which the gas will be pure. The paper is then taken away and the pure hydrogen gas is allowed to strike upon the platinum. If the gas does not take fire, it must be inflamed by a lighted paper, in order to dry the platinum. After that it will act properly. As the acid becomes saturated with zinc, crystals of sulphate of zinc form in the cylinder. At the end of some months the solution must be thrown out and fresh acid put into the cylinder.

Figure 197 represents an ornamental hydrogen lamp, constructed on the same principle.



197.

EXPLOSIVE POWERS OF A MIXTURE OF TWO PARTS OF HYDROGEN GAS WITH ONE PART OF OXYGEN GAS (OXYHYDROGEN GAS).—DETONATING BALLOONS.—Bubbles blown with this mixture, with the help of a bladder and tobacco-pipe, page 200, will ascend in the air, though not so rapidly as those filled with pure hydrogen. But, upon the application of flame, they will explode with far greater violence; without, however, occasioning any accident, unless they are fired before they are away from the pipe.

The best way to prepare this mixture of the gases is as follows:—Use the jar, *a*, figure 198, with the cap, *c*, the stop-cock, *g*, and the connector, *f*, but without the parts marked *e*, *d*, *b*. Fill the jar with water, and place it on the shelf of the trough in the position of the jar represented in figure 132. Transfer from another jar as much oxygen gas as fills thirty measures of this jar according to the graduation, using either a delivery tube like *c*, figure 132, or passing up the gas by means of a small jar. Then, in like manner, pass up sixty measures of hydrogen gas. These proportions make the explosive mixture.

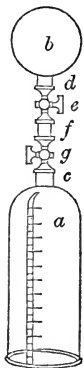

198.

Caution.—Bear in mind the important circumstance, that this mixture is explosive in close vessels, so that if a light is applied to the mouth of a vessel in which it is contained, the whole of the mixture explodes at once, and with such violence as to shatter the vessel, and fling about the fragments in all directions, to the imminent danger of all who happen to be within their reach.

Resin Balloons.—Böttger gives the following instructions for preparing detonating balloons:—Mix eight parts of resin with one part of refined linseed oil, in an iron or porcelain capsule, *b*, placed over a water-bath, *a*. Melt the mixture and retain it fluid at about the temperature of 200° . This mixture may be used instead of soap-lather to blow balloons, either with common air or the gases, using a common tobacco-pipe to blow with. To prevent their bursting on separation from the pipe, they must be allowed to fall on a sheet of paper strewn with powder of lycopodium. These balloons have an elegant appearance in sunshine. If thrown from a high window, they do not burst till they come into contact with the ground.

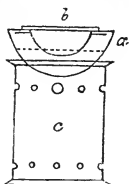

199.

When oxyhydrogen gas is used, and the balloons are blown with the assistance of the bladder-apparatus described at page 200, they may be cautiously deposited upon porcelain plates, strewn with powder of lycopodium. Though excessively thin, they retain the gases perfectly, and for some experiments they are preferable both to bladders and caoutchouc balls.

The explosive power of oxyhydrogen gas may be effectively demonstrated at lectures by one of these balloons. Suppose one to be prepared of from three to four inches diameter, or containing about thirty cubic inches of the mixed gases, and to be lying upon a porcelain plate. The inner surface of your left hand is to be strewn with lycopodium, and the resinous ball is to be gently rolled from the plate to the hand. A lighted paper is to be taken in the right hand, the face turned aside from the left hand, and the balloon to be inflamed. A violent explosion is instantly produced, for thirty cubic inches of oxyhydrogen gas is a large quantity to ignite at once; yet the hand that sustains the explosive mixture is only slightly shaken, and suffers no injury whatever.—*Böttger.*

If a strong solution of soap, contained in a pan or an iron mortar, be blown up by this explosive oxyhydrogen mixture into a large cauliflower head, by means of a bladder and pipe, and a light held at the end of a long stick be applied, an explosion of an extremely violent description is produced, with a report like that of a cannon.

If a similar mixture be put into a strong pint bottle, such as a green soda-water bottle, and the bottle be enveloped in many folds



200.

of a coarse cloth, and the mixture be inflamed by withdrawing the cork and applying a light to the mouth of the bottle, a similar stunning

explosion is produced.—Instead of a glass bottle, a small strong bottle of tin-plate may be used for this experiment. Its capacity may be one

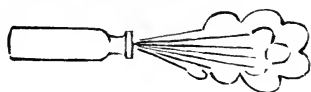

201.

fluid ounce; the neck narrow and provided with a closely-fitting cover, which should be broad enough to serve for a foot. A small quantity of the explosive mixture may also

be inflamed, with perfect safety by means of a strong German glass tube, about three inches long, and of the thickness and diameter of fig. 202.



202.

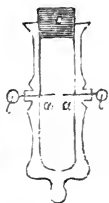

203.

The tube may be held by the fingers. It never bursts if made of well-annealed glass.

The electric spark explodes this mixture as readily as common flame. Figure 203 represents a small cannon made of tinplate or brass. *a a*, are two wires with knobs, *b b*, at their outer ends. The wires pass through small glass tubes set in the sides of the cannon, and approach very near to each other without absolutely meeting. Fill the cannon with the mixed gases at the water-

trough, and close the mouth with a cork. Then pass an electric spark through the mixture from knob to knob. The gases explode, and the cork is thrown out like a shot.

The following is a similar experiment. A large bladder is closed by a cork, through which passes a glass tube, *e*, and two wires, the ends of

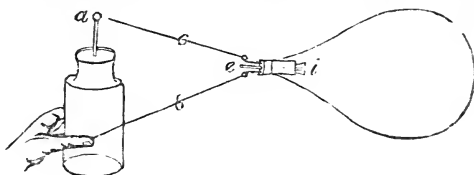

204.

which *nearly* meet inside, and are furnished with knobs outside. The bladder is filled with gas by connecting the tube *e* with the stop-cock of the apparatus depicted at page 169 or 175. The tube is closed with wax when the bladder is filled, and the two knobs are connected by wires with the outer and inner side of a charged Leyden jar. The electric spark passes through the gaseous mixture from wire to wire at *i*, and a tremendous explosion is produced, which shatters the bladder to pieces. If the bladder is large, the noise produced by the explosion is so great as to be unpleasant in a room. It is advisable, therefore, to suspend the bladder out of doors, and to carry long wires from it to the place where the electric spark is to be produced.

The Leyden jar may be charged with electricity by an electrical machine, or by an electrophorus. Figure 205 represents the form of this instrument. The upper part is a disc of brass or tin-plate mounted with a glass handle. The lower part is a plate of pitch, which is rubbed when required for use with a piece of fur, by which the electricity is excited. A convenient form of electrophorus is provided by substituting a rod of gutta-percha for the glass handle of the metal disc, and by using a thin sheet of gutta-percha instead of a pitch plate for the electric.

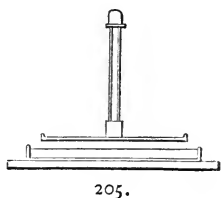

The whole apparatus being made clean and dry, the electric is rubbed by the fur to excite it. You then—holding the handle of the disc merely by the ends of the fingers, and not grasping it in the hand, which soon moistens it and spoils the action—place the metal disc on the electric, touch the disc with your finger, lift it, and hold it to the knob of the Leyden jar, into which a spark will pass from the disc. This is repeated until the jar has acquired a sufficient charge.

A Leyden jar of the capacity of two ounces of water—that is to say, measuring three inches in height and an inch and a half in diameter—is large enough for this purpose. Such a jar can be conveniently charged even in damp weather by means of a glazed porcelain tube two feet long and an inch and a half in diameter, which is to be rubbed with a soft silk cushion smeared with electrical amalgam. The tube while being rubbed must be held close against the knob of the little Leyden jar.

When an electrophorus is pretty large and in good condition, and the weather favourable, it will explode the oxyhydrogen gas by a single spark.

The Oxyhydrogen Blowpipe.—The explosive mixture of oxygen and hydrogen gases, when burnt gradually and with suitable precautions at a small jet, produces an intense degree of heat, possessed of great fusing power. One of the simplest forms of apparatus for this purpose is represented in the margin, and known as *Hemming's's Jet*. It consists of a brass tube *a*, the half of which is closely packed with very fine brass. The end so packed

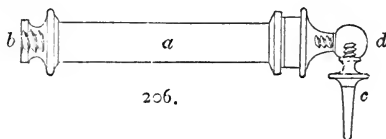

is that nearest to the jet. The perfection or safety of this instrument consists in the fineness and the close packing of these wires. To render them quite tight, after as many as possible are driven in, a stout pointed wire is forced into the middle and acts upon them like a wedge. The interstices between the wires afford a passage for the gases, but do not permit the flame to pass. The reason of this is given in the description of Davy's Safety-Lamp.

The gases are first mixed in a jar and passed thence into a sound bladder mounted with a bladder-piece and stop-cock, as figured in page 169, and the jet is connected with the stop-cock by means of the screw *b*, or the jet may be connected with the gas-bag, fig. 158, either immediately, or with the intervention of several feet of Indian-rubber tube. The stop-cock being opened and the gas-bag pressed, the mixed gas escapes at the orifice *c*, where it is inflamed. A sectional view of the jet *c* is given in fig. 191. The ball *d* of the jet can be removed and the pipe *c* screwed into the tube *a*. This alteration allows the flame to be sent in different directions. This apparatus is not perfectly safe. In careless hands the flame may be permitted to pass back into the bladder, and cause the explosion of the whole mass of gas. The jet should, on this account, never be used in connection with a gas-holder formed of solid materials. The following particulars should be attended to.

1. The caps must be taken from the cylinder *a*, and the wires be examined to see that they remain tightly wedged together.

2. You must not take off the caps and put them on again at the wrong ends of the cylinder. If you do, the unpacked space then brought into the forepart of the tube will explode when you light the gas, and the flame will probably force its way back into the receiver.

3. Though, when everything is in good condition, the jet, fig. 206, may be screwed directly to the bag, fig. 192, and the bag be squeezed under your arm, it is not prudent to run the risk of an explosion under such circumstances; nor is it necessary to put yourself into danger. You can use three or four feet of vulcanised caoutchouc tube, and put the gas-bag under the pressure of a board and weight. The jet may then be taken in the hand without danger.

Experiments with this Blowpipe.—1. A piece of platinum wire or foil melts in the flame easily. 2. If the flame is directed upon a hole in a piece of charcoal containing metals, such as iron nails, and other substances of difficult fusibility in ordinary furnaces, they soon melt. 3. A steel watch-spring burns and throws off brilliant sparks. 4. A piece of lime or magnesia becomes intensely hot, and shines with a light so bright as to be insupportable to the eye. This constitutes what is commonly called the *Drummond light*, which can be conveniently exhibited by the following apparatus.

Drummond Light, or Oxyhydrogen Lime Light.—Fig. 207 shows a safe and elegant form of the oxyhydrogen blowpipe, arranged for exhibiting the Drummond light. The letters O and H represent Indian-rubber tubes which bring the oxygen and hydrogen gases from two different gas-holders, where pressure is kept constant on the gases, and the efflux is regulated by the stop-cocks *o* and *h*. The gases mix in the tube *a* just immediately before being burnt at the jet *b*, and the

light is thrown upon a small cylinder of burnt lime *c*, supported by a wire attached to the table *t*. The lime becomes white hot, small particles of it sublime into the flame, and a most intense light is produced.

The lime can be turned round and raised up and down by means of the screw *d*, and it can be put closer to, or further from, the jet *b*, by means of a screw in the middle of the table *t*. The lime cylinders are formed of well-burnt lime. They are provided with a hole in the axis for the wire which is to support them. As soon as they are turned, they are packed with dry lime powder in glass bottles, each containing one dozen, and the bottles are sealed with corks and cement, to prevent the access of atmospheric air, which soon spoils them.

The jet *b* may be made of platinum, but stout brass is generally used, and when the apparatus is to be used as a blowpipe for fusions, the jet is made in the form of fig. 191.

As represented by fig. 207, the apparatus is mounted on a stand suitable for the lecture-table. The joint in the stand permits the depression of the jet *b*, so that the flame may be directed upon metals or other substances placed on a charcoal support.

Tate's Oxyhydrogen Jet.—Mr. Tate has proposed a form of oxyhydrogen blowpipe, which, if less elegant and convenient than the preceding, has the advantage of cheapness, and is free from danger. *a*, in fig. 208, represents a japanned tin-plate cylinder about 6 inches high and 2 inches wide, fixed on a heavy foot. *b* is a cork which fits it air-tight, but is not fixed or cemented into it. *c* is a tube containing a number of pieces of fine wire gauze. *d* is the blowpipe jet. *e* is a gas delivery-pipe which brings the mixed gas from a reservoir where it is under constant pressure. This tube has a silk

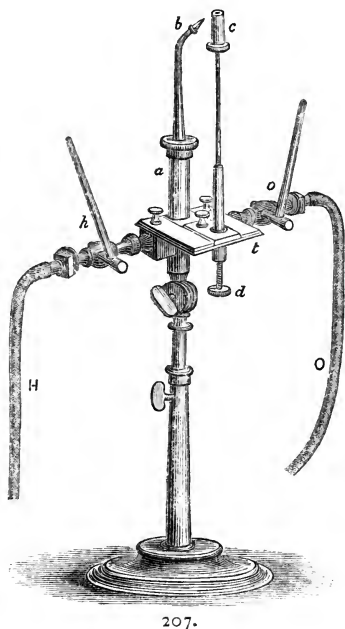

207.

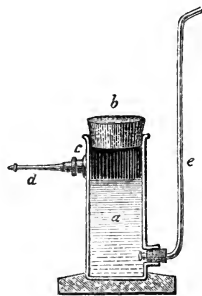

208.

valve tied over its lower end, and it is fitted into the neck of the cylinder *a* by a cork. Between the tube *e* and the gas-holder there is a stop-cock to regulate the flow of gas.

When the apparatus is to be used, water is poured into the cylinder *a* so high as to leave about an inch of space between the surface of the water and the cork *b*. The gas being then set on, the jet is lighted at the orifice *d*, and, if all goes well, the experiments for which the jet is adapted are then to be performed. If the apparatus is in good condition, these experiments are not likely to be interrupted by an explosion. If the pieces of wire gauze placed in the tube *c* are not sufficient in number or fine enough in the meshes, the flame may pass into the space above the water in the cylinder *a*. An explosion will then take place, which will force out the cork *b*, but cause no other damage. The apparatus must be put into such a position that the expelled cork can do no harm to what it strikes. The flame cannot go backwards to the gas-holder through the pipe *e*, because of the intervention of the water placed in the cylinder *a*, and of the valve affixed to the lower end of the tube *e*.

COMPOUNDS OF OXYGEN AND HYDROGEN.

There are three compounds of oxygen and hydrogen; namely, Water, Peroxide of Hydrogen, and Ozone.

WATER.

Symbol, HHO; *Equivalent*, 18; *Specific gravity in the state of Gas*, 9; *Atomic Measure*, 2.

According to the systematic nomenclature, the principles of which have been explained at page 132, this compound would be called *Hydra hydrate*. On the radical theory it is a *salt* containing two radicals with one atom of oxygen, and is the model of those compounds which are commonly called protoxides, with which, as I have elsewhere explained, the sesquioxides should also be brought into harmony, thus:—

H,HO	= water	= hydra hydrate.
Ca,CaO	= burnt lime	= calca calcate.
Ca,HO	= slaked lime	= calca hydrate.
Fe,FeO	= protoxide of iron	= ferrous ferrousate.
Fe,HO	= hydrate of do.	= ferrous hydrate.
Fec,FecO	= sesquioxide of iron	= ferric ferricate.
Fec,HO	= hydrate of do.	= ferric hydrate.

All these compounds are salts formed on the model of water.

PROPERTIES OF WATER.

Water is a liquid of which the most useful properties are universally known, and properly appreciated. Without it neither vegetable nor

animal life could be supported. When *pure*, it is perfectly transparent, colourless, tasteless, inodorous, and not liable to change. At 32° of Fahrenheit's thermometer it freezes, and forms ICE. At 212° it boils, and is converted into STEAM, in which case it expands from 1 volume to 1700. In other words, a pint of water produces 1700 pints of steam. Water is nearly incompressible. It is composed of 16 parts of oxygen to 2 parts of hydrogen by weight, and it can be decomposed so as to produce these elements in the same proportions. 1700 cubic inches of hydrogen gas, and 850 cubic inches of oxygen gas, combine and produce 1700 cubic inches of steam, which condense to 1 cubic inch of water. It is capable of dissolving many substances, and producing solutions. It enters into various solid compounds, in the state of combined water, saline water, water of hydration, or water of crystallisation. Rain water is the purest we see in nature, but even that is never absolutely pure. Spring water has always some mineral impurities, and sea water still more. It is easily purified by distillation, an operation which will be described in a subsequent section.

I have given at page 98 the correspondence of the weight and measure of water according to the English imperial standard.

SOLVENT POWER OF WATER.

Distilled water is the chemist's universal solvent. It is always used first, when an unknown body is submitted to analysis, because it dissolves more substances than any other liquor, and with less alteration of the properties of the things submitted to examination. See page 49.

A liquor supposed to contain something in solution is tried for acids and alcalies by the processes given at page 31, and for solid matters generally as follows:—You put two or three clear drops of the colourless liquor on the flat surface of a slip of platinum foil, or, for want of that, on a slip of window-glass; you slowly evaporate this liquor to dryness: if it consists of water alone, nothing will remain after evaporation. If a white film of solid matter remains, it proves that something exists in the solution. Next, you ignite the solid film by holding the support before the blowpipe flame, or in the flame of a spirit-lamp. If the film disappears, the substance in solution is of a volatile nature: if not, it is a fixed substance.

SUBSTANCES SOLUBLE IN WATER.

Acids, formed by non-metallic simple bodies.	} All of them, acid and neutral.
Alcalies.	
Alcaline Earths.	Sulphates, many.
But Magnesia very little.	Seleniates, many.
Chlorides, } Most of them, both neutral	Alcaline Salts. All, except a few double salts.
Bromides, } and acid.	Sulphurets. Those of the metals of the
Iodides, a few of them.	Alcalies and Alcaline Earths.
Iodates, most of them.	

SUBSTANCES INSOLUBLE IN WATER.

Metals.	Sulphurets, Seleniurets, Carbonates, Borates, Phosphates, Sulphates, Sulphites, Seleniates, Selenites, Salts of the Metallic Acids.	{ All of them, excepting those of the metals of the Alcalies and the Alcaline Earths; and the double Sulphurets and Seleniurets which they produce. Many neutral and basic salts of these and other oxygen acids, where the bases are earths or metallic oxides. Except the neutral and basic salts of the alcalies.
Non-Metallic Elements.		
But Iodine colours water, though it requires 7000 parts for solution.		
Metallic Acids. Except those of Arsenic and Chromium, and the slightly-soluble acids of Vanadium, Molybdenum, and Osmium.		
Metallic Oxides.		
Earths, { The non-alkaline, with the addition of Magnesia.		
Iodides, most of them.		
Bromides, } A few of them.		
Chlorides, }		
Subchlorides. Also many other basic salts of Hydrogen Acids.		

COLOURS OF AQUEOUS SOLUTIONS.

In some cases the colour of a solution indicates the substance contained in it. The following are examples:—

<i>Colours.</i>	<i>Substances probably present.</i>	
Blue,	Copper, Vanadium.	
Green,	{ Copper, Nickel, Uranium, protosalts, Chromium.	Iron, protosalts.
		Molybdenum.
		Manganates.
Yellow,	Neutral Chromates.	
Yellow-Red,	Bichromates.	
Red,	{ Cobalt, Manganese,	Permanganates.
		Bromine.
Brown-Yellow,	{ Iron, persalts, Uranium, persalts, Gold, Molybdenum, Sulphurets.	Platinum.
		Iridium.
		Rhodium.
		Osmium.
Brown,	{ Manganese, persalts, Copper, protochloride, Sulphurets, Molybdenum.	Palladium.
		Iridium.
		Osmium.
Colourless,	{ Alcalies, Metals other than the above. Salts other than the above.	Earths.

METHODS OF COMPOSING WATER FROM ITS ELEMENTS.

SYNTHESIS OF WATER.

It has been already stated, that when oxygen gas and hydrogen gas in the ratio of one volume of the former and two of the latter, or 10 parts by weight of the former and 2 parts of the latter, are burn

together, the product is water. I proceed to show by what experiments this statement is proved to be true.

EXPERIMENT I. *To prove that when Hydrogen gas is burnt in the presence of Oxygen gas, or Oxygen gas in the presence of Hydrogen gas, the product is WATER.*—The figure represents a combination of glass

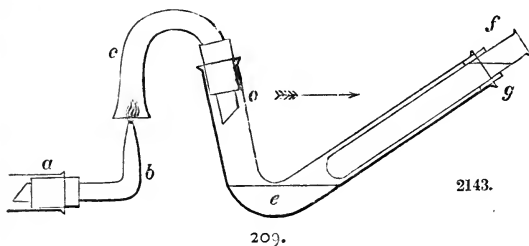

tubes, of which the tube *o e g* is about 10 inches long and $\frac{3}{4}$ inch wide, and the tube *c o* about half an inch in the bore.

A current of hydrogen gas, dried by chloride of calcium in the tube *a*, issues from the blowpipe jet *b*, and is inflamed. The flame should be about $\frac{1}{4}$ inch long. The tube, *c*, must be fixed vertically over the flame. The tube *o e g* must be quite dry. The tube *f* must contain cold water. The diameter of this tube is a little less than that of the tube in which it is placed. It is fixed in its position by two small cork wedges, at *f g*, which are cemented or firmly tied to the tube *f*.

The heat of the flame causes the atmospheric air (consisting, as will be hereafter shown, of oxygen) and nitrogen to rush into the vertical tube *c*. The oxygen of the air combines with the burning hydrogen, and forms water, which passes, in the state of steam, mixed with nitrogen and superabundant air, into the bent tube *o g*. The steam there comes into contact with the tube *f*, containing cold water, and is condensed, while the excess of air and the nitrogen escape into the atmosphere by the spaces at *f g*. In half an hour a considerable quantity of water is collected at the knee *e*.

The method of separating vapours from incondensable gases, by means of the cold water tube *f*, can often be advantageously employed by the practical chemist; as, for example, when digesting substances in a flask with aqua regia, alcohol, and other volatile solvents.

The liquid thus produced can be taken from the bent tube, and examined as to its properties. Thus it can be shown that it is not an acid nor an alkali; that it is wholly volatile, and contains no fixed substances in solution; that it boils at 212° Fahr., &c. In short, that it is water.

By the aid of this apparatus it is easy to collect the water that is produced by the combustion of any substance which contains hydrogen.

For example, water can thus be collected over a burning candle, the flame of an oil-lamp, of a spirit-lamp, or of a jet of coal-gas. All these descriptions of fuel produce a large quantity of vapour of water during their combustion.

When such an apparatus as that just described is not at command, the production of water may be shown by holding over the jet of the philosophical taper, page 202, a small glass globe with a wide neck, fig. 210 in the margin. The water condenses on the inner sides of the globe.



210.

Sir Humphry Davy's Apparatus for burning a jet of Oxygen Gas in an atmosphere of Hydrogen Gas.—The object of this experiment was to illustrate Davy's doctrine, that combustion, or the disengagement of heat and light, is the effect of combination,—and that, strictly speaking, hydrogen is no more entitled to be considered a combustible than oxygen.

With this apparatus a jet of either of these two gases can be burnt in an atmosphere of the other. The experiment is performed as follows:—

The closed tubular vessel is first exhausted at the air-pump. It is then screwed upon a gas-receiver containing hydrogen, and is filled with that gas. It is then screwed upon another gas-receiver containing oxygen gas, which we will suppose to be the condition that is represented by fig. 211. The brass apparatus contained within the tubular vessel is fixed to the caps. When the whole is ready, the stop-cocks are opened and the gas-receiver is pressed downward into the water of the pneumatic trough. At the same instant an electric spark is passed through the tubular vessel between the stop-cock and the brass knob at its upper end. This spark inflames the gas at the jet which is connected with the lower receiver, and in this manner oxygen will burn in hydrogen or hydrogen in oxygen, in both cases producing water.

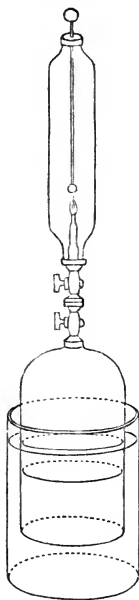

211.

EXPERIMENT 2. *To prove that the Gases combine in the proportion of two volumes of Hydrogen and one volume of Oxygen.*—For this experiment it is necessary to have a *Eudiometer*, one form of which (Volta's *Eudiometer*) is represented by fig. 212 in page 215. It is a strong glass tube, closed at one end, and pierced by two thick platinum wires melted into the glass, and nearly touching one another within. It is graduated into any number of equal parts, such as hundredths of a cubic inch. It is to be filled with, and inverted in, either mer-

cury or water. The latter is generally used. A small quantity of pure oxygen gas is then introduced; and the measure of it is accurately taken by sinking the eudiometer in the trough till the water within and without the tube is at the same level. Twice the volume of pure hydrogen gas is then added, and measured in the same way; or the quantity of the hydrogen gas may be a little more or a little less, the difference being of no importance provided the exact measure be known. The eudiometer is now fixed firmly in the pneumatic trough *e*, as represented in fig. 213, and an electrical spark is passed through the gaseous mixture by connecting the platinum wires, *b* and *c*, with the outer and inner coating of a charged Leyden jar, *d*. See page 206. An explosion is produced, and a quantity of gas dis-



212.

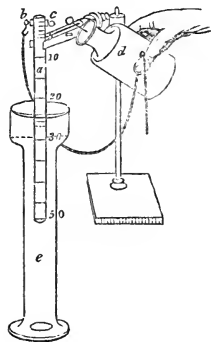

213.

appears. If a residue of gas appears, and another spark is sent through it, no farther explosion is produced. The residual gas, after being carefully measured, may be transferred to a small tube, and tried whether it is oxygen or hydrogen. If the original quantities were precisely two volumes of hydrogen and one volume of oxygen, there will be no residual gas. If the hydrogen exceeded two volumes, there will remain an excess of hydrogen. If the hydrogen was deficient of two volumes there will remain a corresponding excess of oxygen. This experiment, carefully performed, shows, beyond a possibility of doubt, that the two gases combine precisely in the indicated proportions of two volumes of hydrogen and one volume of oxygen. The water produced in this manner cannot be easily measured, even when the experiment is performed over mercury. The intensity of the explosion is such that only a very small quantity of the gas can be operated upon at once, and as 2550 volumes of the mixed gases produce only one volume of water (see page 211), all the water that is produced in one experiment is merely sufficient to damp the surface of the eudiometer.

There is another and a very interesting and convenient method of causing the combination of oxygen and hydrogen to take place; namely, by means of a eudiometer ball of spongy platinum, or, strictly speaking, of a mixture of one part of spongy platinum with four parts of *clay*, the latter being added to prolong and weaken the action of the platinum.

The ball is mounted on a wire of platinum, which is fastened to a longer wire of iron. See fig. 214. The mixed gases being ready in the eudiometer over mercury, the *ball* is ignited in a spirit-lamp flame to dry it, and is then, by means of the iron wire, pushed through the mercury till it comes into contact with the gases, which then combine gradually and without explosion. The apparatus complete is represented by fig. 216. This experiment cannot be made over water.

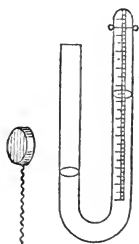

214.

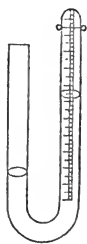

215.

Volta's eudiometer was much improved by Dr. Ure, who contrived the syphon eudiometer, which is represented by fig. 215. This consists of a U-shaped tube closed at one end, and having the platinum wires fixed at the closed end, and having the closed branch graduated. Fill the eudiometer with water, and then pass into it, with the aid of a funnel, a mixture of two measures of hydrogen gas and one measure of oxygen gas. Put in as much as fills about two or three inches of the closed branch. By means of a pipette reduce the water in the open branch of the instrument to the same level as in the closed branch. You can then read off the quantity of the gas by the graduation. Wipe the outside of the tube dry, and grasp it in such a manner that the forefinger of the left hand touches one of the eudiometer wires and the thumb firmly closes the mouth of the tube. The disc of a charged electrophorus is then to be brought against the other platinum wire, upon which a spark passes, and the gases are inflamed. The great heat produced by the explosion expands the gas momentarily, which drives part of the water from the closed branch into the open branch of the instrument. If too much gas is used, part of it is driven over into the

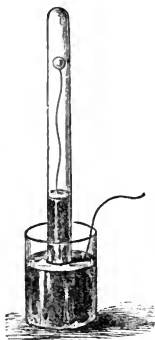

216.

open branch, and the experiment is spoiled. Otherwise the water only is partly driven back. It condenses the air that is left between the water and the thumb, and thus produces a safety-spring. The apparatus is allowed to cool, when the gases, if they were pure, will have entirely disappeared, and the water be found to have risen to the top of the tube. But generally a small bubble of air remains, in consequence of the impurities of the gases or of the separation of common air from the water used to fill the tube.

Cavendish's Eudiometer.—This instrument has acquired a historical celebrity in consequence of its having been used by Mr. Cavendish for the performance of the original experiments which led to the discovery of the actual composition of water. It is represented by fig. 217

which I copy from Sir H. Davy's works. It consists of a very strong funnel-shaped glass vessel, closed at the lower end by a stop-cock, and above by a ground-glass stopper secured in its place by metal bolts. It has two platinum wires like the other forms of eudiometer, for conveying the electric spark to fire the gas contained within it.

When an experiment is to be made, the air is thoroughly exhausted from this vessel by the air-pump. The vessel is then adapted to a receiver, which contains an accurate mixture of two measures of hydrogen gas with one measure of oxygen gas, both pure and dry, and by opening the stop-cock the vessel is filled. Usually the eudiometer and the gas-jar are fitted together with brass connecting pieces in the manner represented by figure 198. When the eudiometer is filled with the mixed gases, the stop-cock is closed, and an electric spark is sent through the wires. A flash is seen, and the gases combine and form water, which condenses on the inside of the eudiometer. The stop-cock is then to be opened, and more of the mixed gas admitted and exploded, and this operation is to be repeated two or three times until an evident quantity of water has been produced in the eudiometer, which, of course, is a product of the combination of the two gases in the proportion of two measures of hydrogen to one measure of oxygen. Not more than three successive explosions can be safely or advantageously made in this apparatus, because the vapour which is produced interferes with the process, and the heat occasioned by the combustions may break the instrument, which is an expensive one.

Mitscherlich's Eudiometer.—Mitscherlich's eudiometer is represented by figure 218. It consists of a very strong glass tube provided with platinum wires, like Volta's eudiometer, figure 212, and is graduated. It has, however, a stop-cock like Cavendish's eudiometer: the object of the arrangement is to permit large quantities of gas to be exploded without bursting the tube, or permitting any of the gas to escape when expanded by the heat of the explosion. This instrument is very difficult to make, it being scarcely possible to anneal the end of it after putting in the wires. The consequence is, that the end of the tube often flies off.

Figure 219 represents a mercurial pneumatic trough, as described by Sir Humphry Davy. It shows, with other tubes, a eudiometer for detonating mixtures of gases. The eudiometer is fixed in a frame which is connected with a spiral spring to secure the tube during the explosion of the

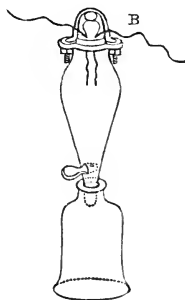

217.

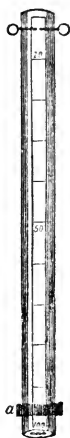

218.

gases. This kind of machinery is only necessary when the gases are to be exploded over mercury and in wide tubes. In all ordinary eudiometrical operations, when the gases are exploded over water and in

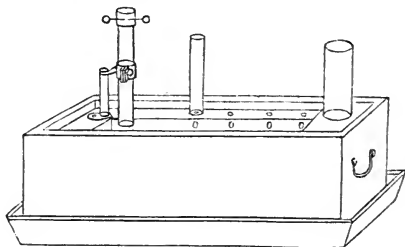

219.

narrow tubes, the eudiometer can be most conveniently held in the hand.

Ettling's Gas Pipette.—Figure 220 represents a gas-pipette contrived by Dr. Ettling for the safe transfer of small quantities of gas from tall narrow receivers into other vessels for analysis.

This instrument may be made of any dimensions, according to the pattern exhibited by fig. 220. It will, perhaps, be acceptable to all chemists who work much with pneumatic apparatus. It renders large pneumatic troughs unnecessary, and presents the advantage that any given quantity of a gas can, by means of it, be taken from a bell-glass or graduated tube standing within a cylinder, and transferred to another vessel without its being necessary to remove the bell-glass from the cylinder for the purpose of decanting the gas. And this transference can be effected with the help of very little liquid.

In using the pipette, the cylinder *a* is first to be filled with water (or mercury) by dipping the branch *c* into the liquid, and sucking at the end *d*. The point *e* is then to be introduced into the tube from which the gas is to be taken, and by sucking again at the point *d* the liquid is removed from the cylinder *a* into the cylinder *b*, while its place is filled by gas from the tube. The apparatus is then pressed downwards until the point *e* dips into the liquid contained in the large cylinder (water or mercury), upon which some of the liquid enters into the branch *c*, and prevents the escape of the gas.

The gas is removable from the pipette by blowing into the end *d* and if the orifice at the end *e* is very small, and the gas is blown out

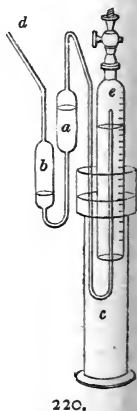

220.

gently, any determinate quantity of it can be thus transferred into an eudiometer or other vessel.

When the liquid that confines the gas is mercury, it is somewhat difficult to blow out the gas, in consequence of the weight of the column of mercury. This difficulty can be lessened by good management.

EXPERIMENT 3. *To prove that 18 parts of WATER, by weight, contain 16 parts of Oxygen and 2 parts of Hydrogen.*—This important fact is satisfactorily proved from the preceding experiment, provided you admit that the specific gravity of oxygen gas is 16 and that of hydrogen gas is 1; because in that case

$$\begin{array}{r} 1 \text{ volume of oxygen weighs} \quad \quad \quad 16 \text{ grains,} \\ 2 \text{ volumes of hydrogen weigh } 1 \times 2 = \quad 2 \text{ grains,} \\ \hline \text{in all} = 18 \text{ grains.} \end{array}$$

But the fact can be demonstrated by experiments of a different character, which consequently afford additional and concurrent evidence.

The substance called black oxide of copper is composed of copper 63.5 parts and oxygen 16 parts. When this substance is placed at a high temperature in contact with pure and dry hydrogen gas, the black oxide is changed into metallic copper, losing weight in the proportion of 16 parts out of every 79.5 parts; while, at the same time, a quantity of pure water is produced, which, when collected and weighed, is found to be at the rate of 18 parts of water for every 16 parts lost in weight by the black oxide of copper. The difference between 18 parts of water and 16 parts of oxygen is 2 parts, which of course is the weight of the hydrogen absorbed in the process. This experiment can be performed with a great degree of accuracy with the help of the following appa-

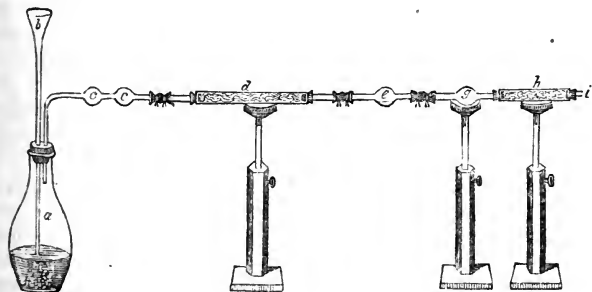

221.

ratus:—*a* and *b* represent a flask for preparing hydrogen gas, in the manner described at page 194. *c c* are bulbs to condense a portion of

the aqueous vapour that rises with the gas. *d* is a tube containing dry chloride of calcium for absorbing moisture from the gas. Instead of this tube any of those described at page 198 may be used. *e* is a tube of infusible glass with a bulb containing black oxide of copper. *g* is a similar bulb destined to receive a portion of the water formed in the process. *h* is a chloride of calcium tube to absorb the residue of the water. *i* is an open tube through which the excess of hydrogen gas escapes into the air. The different portions of this apparatus are connected together by short tubes of Indian-rubber tied on closely. There is a defect in the figure which it is necessary to mention, namely, the tube *e* should project in a long narrow point directly into the centre of the bulb *g*, which is necessary in order to prevent a loss of water at the joint between the two bulbs. The operation is as follows:—The bulb *e* is first weighed empty, and again when half full of well-dried and pure black oxide of copper. The bulb *g* is weighed empty, and the chloride of calcium tube *h*, with its contents, is also weighed. The connections are then made with care. Acid is poured down the funnel *b*, and the hydrogen gas is allowed to escape freely at the orifice *i*. When it has passed away for some time a light is applied at *i*, and if the hydrogen gas burns quietly it may be considered that the atmospheric air is all expelled from the apparatus and replaced by hydrogen gas. Sufficient acid is supplied at *b* to keep up a continuous current of hydrogen gas, and an argand spirit-lamp or a sufficiently strong gas flame is now brought under the bulb *e*. The oxide of copper soon begins to glow, and suffers decomposition, and water is seen to gather in the bulb *g*. When the process is ended, and dry atmospheric air has been sucked through the apparatus to drive out the hydrogen, the tube *e*, with its contents, is again weighed, and the loss of weight or amount of abstracted oxygen is thus found. The tubes *g* and *h* are also weighed, and the gain of weight on the two shows the quantity of water produced and condensed in them. Deducting from this the weight of the oxygen lost by the black oxide of copper, the difference shows the weight of the combined hydrogen.

The following apparatus is an elaborate contrivance for performing this experiment in the most precise manner. A represents the hydrogen gas bottle; B is the wash-bottle for purifying the gas; C D E are bent tubes containing desiccating substances for drying the gas. The oxide of copper is placed in the receiver F, which is formed of infusible glass. This receiver is connected with another receiver, G, in which the chief part of the water produced in the experiment is collected. I is followed by the tube H, which is filled with fragments of pumice stone saturated with strong sulphuric acid, and which is destined to collect the last portions of water.

Before the experiment begins, you weigh, with scrupulous care, the receiver F, clean, dry, and empty. You then weigh it again whe

charged with oxide of copper previously well dried. The difference of the two weighings shows the quantity of oxide of copper submitted to

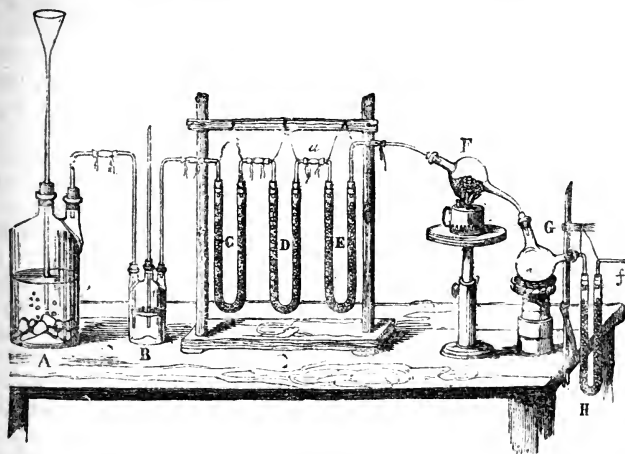

222.

action. With like care the receiver G and the filled tube H are to be weighed, and then the whole apparatus is to be put in connection, as shown by figure 222.

Some acid is then poured into the flask A, and hydrogen is generated slowly. When it is found, by the test already pointed out, that the apparatus is filled with hydrogen gas only, heat is applied to the receiver F, and steadily continued. The combustion of the hydrogen and its combination with the oxygen of the oxide of copper immediately commences. The resulting water trickles down the sides of the receiver G, and settles within it as a liquid; a little vapour which escapes is arrested by the sulphuric acid in the tube H, through which the superfluous gas must pass to reach the open air. The operation is continued until the oxide of copper is entirely reduced to metallic copper.

Remove the lamp and allow the apparatus to cool, under continuance of the current of hydrogen gas. Then separate the apparatus at the caoutchouc conductor, marked *a* in figure 222. The parts F G and H are then filled with hydrogen, which must be replaced by dry atmospheric air before the several pieces can be weighed with accuracy. To effect this replacement the tube *f* of figure 222 is connected with the tube *s* of figure 223. This tube stands in connection with the upper part of an aspirator, V, which is filled with water. At I there is a tube filled with pumice-stone and sulphuric acid, which prevents

the passing back of vapour from the aspirator V into the tube H, which would cause an error in the weight of the water. You open the stopcock *r*, the water escapes, and is replaced first by the hydrogen gas of the vessels E, F, G, H, and then by the atmospheric air, which enters at *a*, is dried in the desiccating tube E, and then passes through the entire apparatus and expels the hydrogen gas. The regularity of the flow of water depends upon the dip of the tube below the surface of the water in the aspirator V.

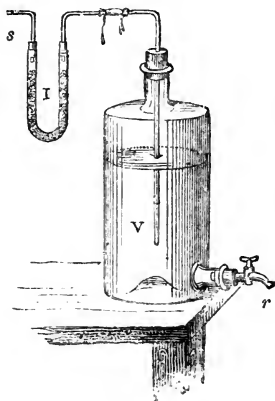

223.

You weigh separately the receiver F and the receiver G with the tube H. The difference between the weight of the receiver F containing the oxide of copper before the experiment, and that of the same receiver containing the reduced copper, gives the weight of the oxygen which has been converted into water. The augmentation in weight of the receiver G and the tube H gives the weight of the water produced.

The most precise experiments made on this plan show that 100 parts of water consist, by weight, of

Hydrogen . . .	11.11
Oxygen . . .	88.89

100.00

which is equal to oxygen 16 plus hydrogen 2, or H₂O.

As the synthesis of water, conducted on the above plan, occupies much time, it is not adapted to be shown at a lecture. But the inter-

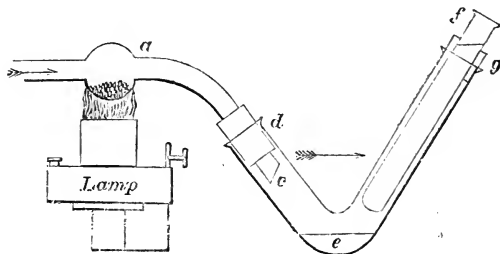

224.

esting experiment of the production of water, by passing dry hydrogen gas over dry black oxide of copper, can be easily shown at a lecture by

means of the following modification of the apparatus. *a*, figure 224, is the hard glass bulb tube containing the oxide of copper. The end of this modified tube is bent downwards and cut aslant to allow the water to run easily out of it, and it is connected by a cork, *d*, to the bent tube *c e g*, which is fitted with a cold water condensing tube, *f*, in the manner described in page 213. The dry hydrogen gas is passed in the direction indicated by the arrows, and a considerable proportion of the water produced collects at the bend *e*; but since a little of the water escapes in company with the excess of hydrogen gas at the opening *f g*, there can be no conclusions drawn from this experiment as to the *weight* of the water produced.

ANALYSIS OF WATER.

METHODS OF DECOMPOSING WATER INTO ITS ELEMENTS.

We have examined several methods of composing water by combining its two elements. Let us now examine the means by which we can analyse water, or separate its elements from one another.

Decomposition of Water by the Alcaline Metals.—The interesting experiment described at section *g*, page 196, affords an example of the analysis of water by an operation which is of easy performance, so as to give results approaching to truth, but which is difficult of very accurate performance. We can, however, approach to a quantitative result, and as the experiment is of a direct and decisive kind it demands our care. The quantity of the hydrogen gas produced in the experiment can be estimated by using a tube so graduated as to show the weight of the gas. A tube 1 inch wide and 12 inches long will contain $\frac{1}{10}$ grain of hydrogen gas, readily divisible into 100 degrees. To fill that tube with hydrogen gas will require $\frac{1}{10}$ atom of metal, namely, 3.9 grains of potassium, or 2.3 grains of sodium. There are two methods of estimating the amount of the metal. 1st method. Weigh a bead of about the required size in a small bottle containing naphtha, and weigh with it a pointed iron wire and a piece of blotting-paper. When the gas-tube is filled with mercury and a little water, and is inverted in the trough, remove the metal from the naphtha by the iron wire, wipe it quickly on the blotting-paper, and put it into the inverted gas-tube. Again weigh the bottle with the naphtha, wire, and blotting-paper, and determine the weight of the metal from the difference or loss. The weights of the hydrogen and of the metal being thus approximately determined, they may be compared with the following equations:—

For Potassium :

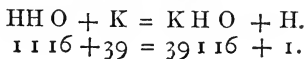

For Sodium :

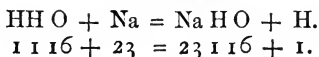

The result cannot be very accurate, because the gas is saturated with moisture, and will differ in measure according to the temperature, barometric pressure, &c.

Instead of weighing the alkaline metal, its quantity may be found by a subsequent analysis of the alkaline solution produced in the tube. The solution of potash or soda is conveyed into a glass jar, the whole of it being carefully washed from the graduated tube with distilled water. The amount of potash contained in it is then determined by the alcalimetric process of adding test acid from a centigrade alcalimeter. The composition of these alcalies being known, it is easy to compare the weight of the hydrogen set free with the weight of the oxygen and hydrogen combined with the potassium or sodium to form that quantity of potash or soda which the test acid detects in the solution.

Caustic Potash contains—

$$\begin{array}{r} \text{K} = 39 \\ \text{H} = 1 \\ \text{O} = 16 \\ \hline 56 \end{array}$$

Caustic Soda contains—

$$\begin{array}{r} \text{Na} = 23 \\ \text{H} = 1 \\ \text{O} = 16 \\ \hline 40 \end{array}$$

Galvanic Decomposition of Water.—The apparatus figured in the margin represents a bottle of the capacity of six or eight ounces of water, containing a pair of parallel metallic plates communicating with two external wires, and a gas-leading tube passing through the cork and communicating with a small pneumatic trough, where T is a graduated gas tube, and B a beehive shelf to support it. The plates within the bottle act best when made of platinum, in which case the liquor put into the bottle is water acidulated with sulphuric acid to make it a conductor of electricity. But as this metal is expensive, the plates may be made of iron, and the

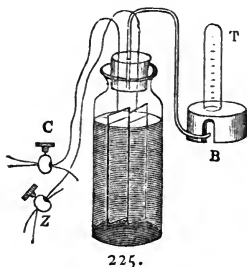

liquor must then be rendered a conductor by the addition of a little caustic potash. The wires may be either of platinum or copper. The binding screws C, Z, are of brass. The apparatus being prepared, and the galvanic battery in action, the wire, C, is fastened to the wire proceeding from the copper end of the battery, and the wire, Z, is similarly attached to the wire proceeding from the zinc end of the battery. The ends of all the wires before being put into the binding screws must be cleaned bright with scouring paper. If the battery is

powerful enough, the current of electricity that now passes through the bottle will decompose the water into the explosive mixture of two volumes of hydrogen gas and one volume of oxygen gas, which will pass into the gas tube, T, and may be analysed or examined. If collected in small strong tubes of 3 by $\frac{3}{4}$ inches, the gaseous mixture may be safely exploded by lifting the tube from the water and presenting its mouth to a candle. See page 206.

When the battery which is to be used is of considerable power, say six jars of Bunsen's coke battery, of one quart size, then the decomposing apparatus may have the form represented by figure 226. In this apparatus, *a* is a glass jar of about three inches in diameter, and twelve inches in height, on a foot. It contains two cylinders of sheet iron, roughened with punched holes, and separated from one another by rods of wood or glass. They are connected respectively by wires to the binding screws *b* and *c*, which are connected with the two extremes of the galvanic battery. The jar is filled with a solution of caustic potash. The tube *d* conveys away the mixed gases produced by the decomposition of the water. If the battery is of the size above mentioned, this apparatus yields a rapid current of gas. In constructing this apparatus, the two wires which join the iron plates to the binding screws, *b*, *c*, and also the tube *d*, may be passed through a cork which accurately fits the mouth of the jar, *a*.



227.

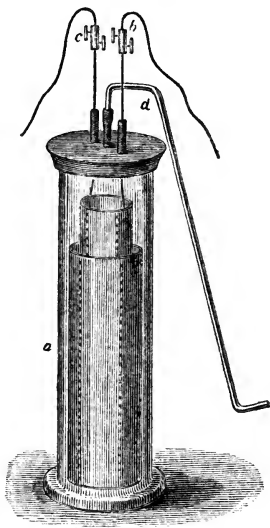

226.

But a better method of adjustment is to use a caoutchouc cap with three necks, figure 227, the wide part of which is tied round the neck of the jar, and the three necks respectively tied round the wires and the delivery tube.

Method of conducting this Experiment so as to deliver the Oxygen Gas and Hydrogen Gas in separate vessels.—Instead of the apparatus described above, it is necessary to use two tubes, having a plate of metal in each, as represented by figure 228 in page 226, where *o* is the tube for collecting the oxygen gas; *h*, the tube for collecting the hydrogen gas; *a*, a bent tube containing acidulated water; and *p, p*, the two platinum plates terminated exteriorly by rings, into which the connecting wires from the galvanic battery are hooked. The tubes,

o, and *h*, should be graduated, to show the respective quantities of the two gases released by this experiment. This form of apparatus is

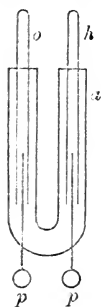

226.

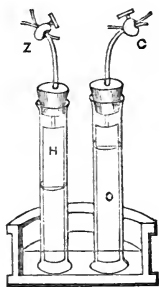

229.

difficult of construction, and may be replaced by the following, which is very easily put together and convenient in use, though not so effective as the foregoing. *O*, *H*, are two glass tubes, open at the lower end, and closed above by corks, through which pass copper wires soldered below to slips of thin platinum foil, which may be six inches long by one inch diameter, or any other size to fit the tubes. The latter are filled with acidulated water, and placed in a small china pan containing the same liquor. The other ends of the copper wires are then connected by the binding screws, *C*, *Z*, to the copper and zinc ends of the galvanic battery. After some time, more or less considerable according to the strength of the galvanic

battery, the water in the apparatus is decomposed, and the oxygen gas and hydrogen gas are collected in the two tubes, without any admixture of the gases the one with the other. In proportion, the gases collected are two volumes of hydrogen to rather less than one volume of oxygen. The reason of the deficiency in the quantity of the oxygen gas is commonly said to be, that oxygen gas is more soluble in water than hydrogen gas. I am, however, of opinion, that in this analysis of water, a quantity of peroxide of hydrogen is usually produced, which is to a certain degree rendered stable in consequence of the presence of the sulphuric acid, and thus occasions a deficiency of free oxygen.

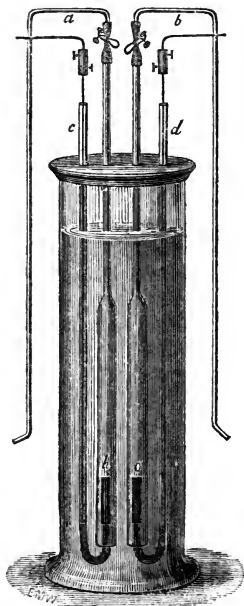

230.

Buff's Voltameter.—The apparatus represented by figure 230 is very well adapted for the decomposition of water before a class when large battery power is used. It is contained in a glass jar about sixteen inches high and four inches in diameter. *o* and *h* are two very narrow bell receivers, formed of glass tubes, connected above by means of stop-cocks, or of caoutchouc tubes

and pinchcocks, with the gas tubes *a* and *b*, through which the oxygen and hydrogen gases can be separately conveyed into any desired vessels. *c* and *d* represent very narrow bent glass tubes, the lower parts of which are filled with mercury. Into the short branch of each of these tubes is plunged the end of a cylinder of platinum, which rises thence into the bell tubes *o* and *h*. Down the long branches of these narrow tubes are plunged, till they reach the mercury, copper wires connected with two binding screws, and thereby with the two poles of the galvanic battery. The jar is filled with acidulated water. The parts of the apparatus are held together by a cover or top-piece, composed of wood and cork, which keeps the respective pieces of the apparatus in their proper relative positions. From this apparatus, either oxygen or hydrogen gas is readily obtainable.

Figure 231, and letter B of figure 236, represent two other forms of voltameter for collecting separately the two gases produced by the galvanic decomposition of water.

Management of the Apparatus, figure 231.—Fill the tubes *a* and *b* with water slightly acidulated with sulphuric acid. Place two fingers over the open ends, and invert the tubes into the glass vessel *c*, also nearly filled with the same liquid. Take care to place the tubes in such a position, that each shall cover one of the upright pieces of platinum that are fixed in the bottom of the glass, and that the pieces of platinum do not touch each other. Fix the terminal wires of the galvanic battery to the binding screws, *d*, *e*, placed in the wooden foot of the apparatus. Oxygen gas will then be evolved in one tube, and hydrogen in the other, displacing the water. If only one glass tube is used, and that is placed over both the platinum plates, but so as to prevent their touching one another, the oxygen and hydrogen will then be collected together, constituting the explosive gas mixture.

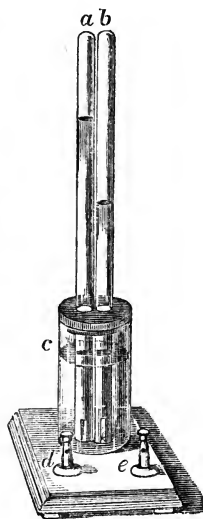

231.

Preparation by Voltaic Action of Pure Hydrogen Gas for Eudiometrical researches.—Hydrogen gas prepared with zinc in the usual method is too impure for analytical researches on other gases. The best way to prepare pure hydrogen is by the action of the galvanic battery, with which the gas-bottle represented by figure 232 may be used. This consists of a common gas-bottle, mounted as follows:—*a* is a stout wire of platinum, sealed into a hole drilled in the flask near to the bottom. The wire is covered in the bottle by a bed of amalgam of zinc, *b*, prepared with pure materials. The flask is filled to within

an inch of the cork with perfectly pure diluted sulphuric acid. *c* is a narrow slip of platinum plate, suspended by a platinum wire, *d*, which passes through the cork, with which the bottle is closed air tight. The plate *c* must come near to, but not touch, the amalgam, *b*. A gas delivery tube passes also through the cork, and is adapted to a tube filled with chloride of calcium, *e*, to dry the hydrogen when it is required dry.



232.

When this apparatus is to be used, the galvanic battery of two or three jars is put into connection with the wires, *d* and *a*, of the gas-bottle, the positive pole in connection with *a*, and the negative pole with *d*. The gas immediately begins to rise from the platinum plate

c. It should be allowed to escape freely for half-an-hour, in order to carry off the atmospheric air of the gas-bottle. It then goes over in a state of purity.

Decomposition of Alkaline Salts by Galvanic Action.—This pleasing and instructive experiment, having some relation to the foregoing, may

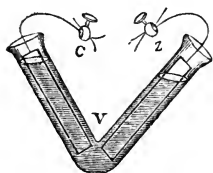

233.

be described here. The V-tube is filled with a weak solution of sulphate of soda, coloured by blue cabbage liquor. A plate of copper foil soldered to a copper wire is inserted at each end, and connected by the binding screws, C and Z, with the galvanic battery. The sulphate of soda is soon decomposed; the soda being disengaged at one end of the V-tube, where it colours the cabbage liquor green, and the sulphuric acid being set free at

the other end of the tube, colouring the liquor red; the central portion of the liquor retaining its blue colour. By attaching the wires at C, Z, to the contrary poles of the battery, the changes of colour may be reversed.

THE GALVANIC BATTERY.

The decomposition of water, and chemical decompositions generally require a galvanic battery consisting of a considerable number of cells. The experiments described in the preceding pages can be made with Smee's or Bunsen's battery, consisting either of six large cells or ten small cells. Smee's is the more convenient kind of battery for use.

in a class-room, or a dwelling-house, but Bunsen's is the more powerful. Grove's battery is more powerful than either of these, and it is less troublesome than Bunsen's battery, but it is too expensive for common use.

BUNSEN'S CHARCOAL BATTERY.—Figs. 234, 235, represent two varieties of Bunsen's Charcoal Battery. Of these, fig. 234 represents

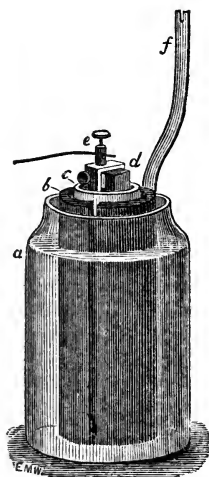

234.

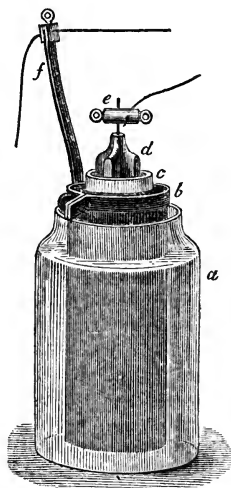

235.

the one which has most power when freshly put in action, but fig. 235 the one which has the most sustained action.

Description of fig. 234. *a*, is a glass jar to hold the exciting solution; *b*, a cylinder of zinc open at both ends; *c*, a porous earthen pot; *d*, a rectangular block of coke; *e*, a binding-screw attached by a brass collar to the coke; *f*, a slip of copper soldered to the zinc cylinder.

Description of fig. 235. *a*, is the solution-glass; *b*, a pot or cylinder of coke with a solid bottom; *c*, a porous earthen pot; *d*, a bar of zinc cast with four deep longitudinal grooves, giving its cross-section the form of a cross (+), and serving to increase its surface; *e*, is a binding-screw attached to the zinc; *f*, is a binding-screw attached to a slip of copper, which is fastened by a brass collar securely to the coke cylinder *b*.

The cokes or charcoals required for these batteries are the subject of a special manufacture. The slips of copper, *ff*, are made flexible in order that they may be easily bent to connect the pairs with one another.

Dimensions of these Batteries.—Fig. 234. Glass cylinder *a*, 6 inches high, $4\frac{1}{2}$ inches diameter. Zinc cylinder *b*, 6 inches high, $2\frac{3}{4}$ inches

diameter; substance about $\frac{1}{8}$ inch. Porous pot, *c*, $5\frac{1}{2}$ inches high, 2 inches wide. Coke block, *d*, 6 inches long, 2 inches wide, $\frac{7}{8}$ inch thick.

Fig. 235. Glass cylinder, *a*, $6\frac{1}{2}$ inches high, 4 inches diameter. Coke cylinder, *b*, $6\frac{1}{2}$ inches high, $3\frac{1}{4}$ inches diameter; substance $\frac{1}{2}$ inch. Porous pot, *c*, 6 inches high, 2 inches diameter. Zinc block, *d*, 7 inches long, $1\frac{1}{2}$ inch across.

Small size of battery, fig. 235. Glass cylinder, 4 inches by 4 inches. Coke cylinder, $4\frac{1}{2}$ inches high, 3 inches diameter; $\frac{3}{8}$ inch substance. Porous pot, 4 inches high, $1\frac{3}{4}$ inches diameter. Zinc block, 4 inches high, $1\frac{1}{2}$ inches diameter.

Exciting Solutions for the Coke Battery.—When fig. 234 is used, the porous earthen pot, *c*, is to be filled with the strongest nitric acid, and the glass cylinder, *a*, with diluted sulphuric acid, which, for ordinary experiments, may consist of 10 parts of water with 1 part of oil of vitriol. If powerful action is required the quantity of water may be diminished to 7 or 8 parts.

When fig. 235 is used, the nitric acid is to be put into the glass jar, *a*, and the diluted sulphuric acid into the earthen pot, *c*. As this form of apparatus is generally employed when a more moderate and continuous action is required, the nitric acid need not be so concentrated as when it is to be used in the apparatus fig. 234.

The diluted sulphuric acid must be suffered to become quite cold before it is put into the cells. The acid contained in the glass jar *a* and the porous pot *c* must in all cases be at the same level. It is necessary, therefore, to ascertain by previous measurement with water how much liquid requires to be put into the porous pot and the glass jar respectively to produce the required level. When a powerful effect is required, the batteries should not be charged with acid till the time is come to make the experiment. The operator should then know exactly how much by measure he has to put into each vessel. When people are waiting to see the experiments performed, it is not then the time to gauge the vessels, or prepare the proper quantity of acid.

All the pieces of metal about the battery should be perfectly clean, and where metallic surfaces are to be brought into contact for connection, such as the ends of wires, points of binding-screws, &c., they must be bright and free from oxide. The brass collar attached to the coke must be firmly screwed to it. Sand-paper or a file can be used to clean the metal surfaces. When several jars are used, the slip, *f*, of each jar is connected with the screw, *e*, of the next jar; finally there will be one free slip, *f*, and one free screw, *e*, to connect with the two wires of the apparatus through which the galvanic current is to be passed; such as *b c* in fig. 226 and *c d* in fig. 230.

The decomposition of the nitric acid, which occurs during the action of this battery, gives rise to a disengagement of abundant vapours of

nitrous acid, which render it indispensable to put the battery either out of the room in which the experiments are to be made, or into such a position that a draught of air can carry off the vapours. Copper wires covered with cotton can be brought from the battery to the spot where the experiments are to be made. These wires can sometimes be brought with convenience through two holes bored in the wooden frame of a window, and lined with bits of glass tube.

Professor Frick suggests a remedy against the odour of the nitrous acid which, to me, would be something worse than the disease, but which some of my readers may not so strongly disapprove of. His antidote is tobacco. When you make experiments with Bunsen's battery, you are to smoke a cigar.

When the experiments are completed, the battery should be dismounted as soon as possible. The cokes should be put into a small quantity of water to extract the nitric acid with which they are saturated, and which, in a diluted state, may be useful for some purposes. The cokes should then be washed repeatedly in large quantities of water, to take out all the nitric acid, otherwise they will continue to give off nitrous acid for weeks afterwards, and damage all metallic apparatus exposed in their neighbourhood. The brasses, also, should be disconnected, and well cleaned from the nitric acid. The necessity of attending to these particulars causes some trouble, and the waste of nitric acid is considerable. These are drawbacks to the use of this powerful battery. In Grove's battery, plates of platinum are used instead of blocks or cylinders of coke, and as these do not absorb the nitric acid, there is far less trouble with Grove's than with Bunsen's battery.

When a battery is required very frequently, and for short operations, the cell, figure 235, possesses some advantages over that shown in figure 234. The porous pot, *c*, can be readily taken out, and the action of the coke upon the nitric acid then ceases. The coke can be left in the acid till the battery is required again. The loss of acid occasioned by washing the coke is thus avoided. Clean and dry cokes have greater power than such as have been for some time immersed in the acid; but that activity soon settles down to the normal power.

When a long continued and regular though feeble power is required, the Bunsen's battery may be charged both in the glass jar and the porous pot with water containing $\frac{1}{3}$ or $\frac{1}{5}$ of its volume of sulphuric acid. In that state it will give a pretty uniform current of electricity for an entire month.

The Porous Pots.—They must be thoroughly porous, but free from cracks. When filled with water they should, *after a minute*, be thoroughly wet on the outside. They must not let water run down in stream, or even in drops. If they contain holes or cracks, the nitric acid passes through and attacks the zinc. The visible sign of this is that the zinc looks black. Such a pot must be rejected. After an

experiment, the porous pots should be removed from the battery, be thoroughly washed, and then be soaked in water for 24 hours; otherwise, sulphate of zinc remains in them, and becoming crystalline, renders the pots brittle and useless.

It is essential for the good working of a battery that the zinc and coke should not be placed too far asunder. The porous pot must therefore be thin, and there must be but little space left between the pot and the zinc on one side, and between the pot and the coke on the other side.

Amalgamation of the Zincs.—By amalgamating the zincs of a battery we destroy local action arising from the presence of impurities in the metal. The power of the battery is increased, and the zincs are rendered more durable, and therefore less costly. To amalgamate the zincs, take in a capsule a mixture of equal parts of water and muriatic or sulphuric acid, and add a little mercury. With a brush or a rag tied to a stick rub the acid and mercury over the zinc until a coating of silver-looking amalgam covers the surface of the metal. Old zinc should be now and then revived by this operation. The mercury which has thus been brought into contact with zinc must be reserved for the purpose, being no longer pure.

SMEE'S BATTERY.—Fig. 236 represents a set of six cells of Smee's battery, arranged in a single case, and attached to rackwork, by which

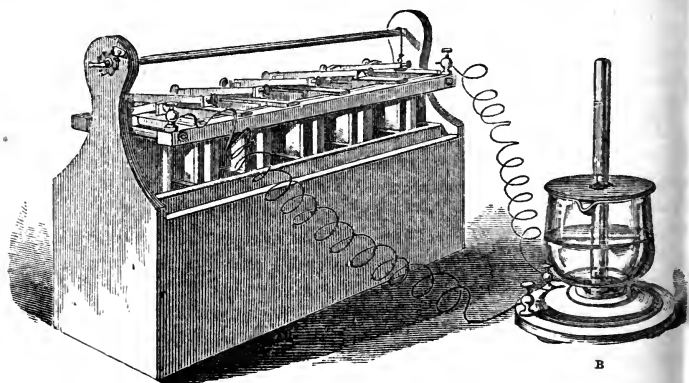

236.

the plates can be simultaneously sunk into the acid cells, or raised out of them, more or less, according to the power demanded for any particular experiment.

Each cell of Smee's battery contains a plate of platinumized silver arranged between two plates of amalgamated zinc. By platinumized silver is meant a thin sheet of silver upon the surface of which pulverulent platinum is closely deposited in such a manner as to give it a certain

degree of roughness. The two zinc plates and the plate of platinised silver are attached to a piece of wood so formed as to receive two binding-screws, one of which is connected with the platinised silver and the other with the zinc. Fig. 237 represents a single cell of Smee's battery. *a* is the binding-screw that is connected with the pair of zinc plates; *b* the binding-screw connected with the platinised silver; *c* is the block of wood which holds the whole together; *d* a glass or china jar to contain the acid; *e e* the two zinc plates having the platinised silver between them.

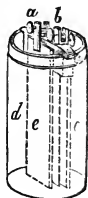

237.

The exciting liquor for this battery is water mixed with from one-seventh to one-tenth of its measure of sulphuric acid. The stronger the liquor the more rapid is its dissolving action on the zincs. The liquor with $\frac{1}{10}$ acid is sufficiently strong for most purposes. No other acid is to be added. The zincs must be amalgamated and the brass-work must be kept perfectly clean.

The rack-work attached to the apparatus (fig. 236) serves to lift the whole of the plates out of the acid cells and to keep them suspended in such a position that they can at any time be lowered into the acid when required for an experiment. When only a small power is required, the plates are suffered to dip only a little way into the acid. When the full power of the battery is required they are let down to the bottom. When the experiment is finished they are immediately wound up out of the acid, to prevent useless expenditure of acid and zinc.

The battery, fig. 236, is commonly provided with two sets of copper connecting-bands. One set consists of a single pair of long bands, which extend the whole length of the battery: to one of these bands all the zincs can be attached and to the other all the platinised silvers. This arrangement is used for certain experiments which demand the greatest *quantity* of electricity, but not the greatest *intensity*. The other set of connecting-bands consists of six pieces shaped something like the letter *s*. By these the binding-screws connected with the zincs and the silver plates are connected alternately from one end of the battery to the other, so that the plates come in the order of zinc, silver, zinc, silver, &c. This arrangement is necessary when chemical decompositions and other phenomena requiring intensity of electricity are to be produced by the battery; and, indeed, this is the arrangement best suited for most galvanic experiments of an elementary nature.

As Smee's battery gives off only hydrogen gas when in work, it is not so disagreeable a companion in a close room as Bunsen's battery with its constant discharge of nitrous acid.

The power of the arrangement represented by fig. 236 is sufficient to yield one cubic inch of the mixed gases per minute. It will heat to redness four inches of fine platinum wire, fuse iron wire with facility,

and enable a sufficiently strong electro-magnet to lift many hundred weight. This power, however, is much inferior to that possessed by six pots of the coke battery, represented by fig. 234.

The apparatus represented by letter B, in fig. 236, is a voltameter, and has been referred to at page 227.

Theory of the Galvanic Decomposition of Water.—When water that is perfectly pure is put into a vessel of pure gold, placed in a vacuum, and submitted to the action of a very powerful galvanic battery, it shows scarcely any signs of decomposition; and there is a probability that, if it were possible to apply the galvanic current to water perfectly pure and effectually separated from the action of extraneous bodies, there would be no decomposition effected at all. Hence we are led to ask, whether the decomposition of water by galvanic action, which, as commonly practised, appears to be so easy and certain, is not a mere secondary effect, depending upon the reactions on the water of the chemicals which are galvanised in connection with it? Such I believe to be the case. The addition of sulphuric acid, of caustic potash, and of other salts, to the water which is to be decomposed, is usually said to be for the purpose of improving the conducting power of the water; but I think it ought to be said to be for the purpose of supplying the subjects upon which the primary action of the galvanic power is to be exercised. Thus, supposing the decomposing action to take place upon hydrated sulphuric acid, we may conceive it to occur as is represented in the following short series of atoms:—

Before the current is passed.

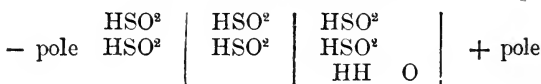

After the current is passed.

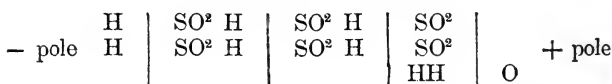

In this manner a multitude of particles of hydrated acid lying between the two poles of the battery may be decomposed and recomposed, and yet the only result appears to be the decomposition of a single atom of water. The evidence that this view of the question is correct is found in the fact, that if a break is made in such a series of atoms, and the products of the electrolysis are examined at the break, the quantity of decomposition which is there manifested coincides with that which appears at the ends of the chain. Hence the quantity of oxygen and hydrogen which is given off at the two poles are a token of the acting power of the galvanic current and of the work which it is doing upon

all the atoms which form the chain between its + pole and its - pole. Accordingly, the separation of one volume or one atom of oxygen at the positive pole is an indication of the separation of two volumes of hydrogen—two radicals—at the negative pole. These two radicals indicate also the amount of the galvanic action operating at any point in the series, namely, *an action such as will separate two basic radicals from two acid radicals*. I speak of *radicals*, and not of *atoms*, because experiment proves that the decomposing action acts upon radicals *as radicals*, without reference to their weight as atoms. Thus the same amount of acting galvanic power separates from salts quantities of basylous and basylic radicals which are equivalent to the weights of these radicals respectively, and not such as correspond with a single atomic weight when both radicals indicate one metal. Hence, *for one volume of oxygen set free in the voltameter*, we find that, in the cells,

Stannous chloride = $(\text{SnCl})^2$ gives Sn^2 weighing 118,
 Stannic chloride = $(\text{SnCl})^3$ gives Sn^3 weighing 59.

And corresponding, when the current from the voltameter goes first through cupric sulphate and then through cuprous chloride, twice as much copper is deposited in the latter as in the former,

Cupric sulphate = $(\text{CuSO}^2)^2$ gives Cu^2 weighing 64.
 Cuprous chloride = $(\text{CuCl})^2$ gives Cu^2 weighing 128.

These relations, which have been established by the recent experiments of Professor Magnus of Berlin, appear to me to prove decisively the perfect correspondence of chemical radicals with galvanic equivalents, while they also justify the assumption that the quantity of hydrogen in water is *the equivalent* of two radicals, and consequently is two radicals. If we take an atom of water as the measure of galvanic power, we find for every volume of oxygen or two volumes of hydrogen set free in the voltameter, a simultaneous decomposition of two salts, each containing two radicals; it being, at the same time, of no importance whatever, whether the salts be oxidised or not oxidised, or whether the radicals be basylous or basylic.

If, on the contrary, we take as the measurer of the galvanic power a substance which is undoubtedly constituted of two radicals only, then the decomposition which is found to occur simultaneously is restricted in amount to one equivalent of the salt that is subjected to examination.

Thus, when fused chloride of lead forms the voltameter, for every atom of lead which is deposited in the voltameter there is decomposed in the cells one atom of sulphate of soda, or one atom of chloride of sodium:—

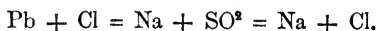

Consequently, an atom of chloride of lead = PbCl is the equivalent

of one salt containing two radicals, while an atom of water = H,HO is the equivalent of two salts each containing two radicals. These facts are important as respects the question whether water should be held to contain one atom of hydrogen or two atoms. The evidence in favour of the latter opinion is almost equal to demonstration. They are also important in showing that radicals are equivalent to one another as decidedly in a voltaic sense as in a purely chemical sense, thus:—



whereas, the experiments which prove that the same electric current can sometimes liberate 118 parts of tin and sometimes only 59 parts, sometimes 128 parts of copper and sometimes only 64 parts, cannot be held to prove the truth of the doctrine set forth by Dr. Faraday, that "electro-chemical equivalents coincide, and are the same with ordinary chemical equivalents." That doctrine is no longer in accordance with established facts, and, unless the Radical Theory be adopted, the relations between chemistry and galvanism are become utterly discordant.

This subject is discussed at length in my work on the "Radical Theory." See the chapter on "The Evidence of Electrolysis in favour of the Radical Theory," page 547.

I have assumed in the preceding explanations that when aqueous solutions are decomposed, the gases that are given off are in the proportion of two volumes of hydrogen to one volume of oxygen. That is what is generally observed. But in certain cases, depending upon the kind of salt that is submitted to electrolysis, and upon the concentration of the solution, there is found to be a deficiency in the quantity of oxygen. The reason of this deficiency is, that part of the water escapes complete decomposition. H,HO is converted into H and HO. The latter is the peroxide of hydrogen. This sometimes remains in the solution about the pole where the oxygen is disengaged, being rendered somewhat stable by the acid present in the liquor, and sometimes combines with more oxygen, and forms ozone = HO², which diffuses itself in the liberated oxygen, and gives to it the odour and the other properties of ozonised oxygen. According to Dr. Andrews, the development of ozone occurs in the highest degree during the electrolysis of a mixture of equal measures of water and oil of vitriol.

PURIFICATION OF WATER.

It being impossible to make any progress in analytical chemistry, or in any exact chemical experiment, without the use of pure water, I shall describe several methods of performing the operation of *Distillation*, by which common water is rendered pure. Figure 238 shows very clearly the nature of the process of distillation. *a*, is a small glass retort containing water that is made to boil by the flame of a spirit

lamp. *cb*, is a bent glass tube open at both ends and serving as a receiver. To prevent the latter from becoming warm, in which case the steam would escape uncondensed at the upper end, cold water, or a rag wetted with cold water, is applied outside the tube *b*, or a cold water condensing tube is inserted into *b*, in the manner explained at page 213. In either case pure water soon condenses at the bend *c*.

When the impurities contained in water submitted to distillation are more volatile than water, they go over with the first portion of water distilled, which ought therefore to be thrown away. When they are less volatile than water, they remain in the retort after the water has distilled over. Commonly, therefore, the middle portion of the water distilled is the purest. The distillation ought never to be continued to dryness. When a water contains muriate of magnesia, it must be mixed with lime before distillation, otherwise the distilled water will contain muriatic acid. When carbonate of ammonia is present in an impure water, a little sulphuric acid must be added, otherwise ammonia distils over with the water.

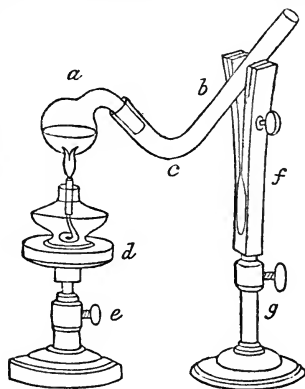

238.

The next figure represents an apparatus for distilling water in quantities for use;—*S* is a tinplate still of the capacity of 2 quarts, *f* is a

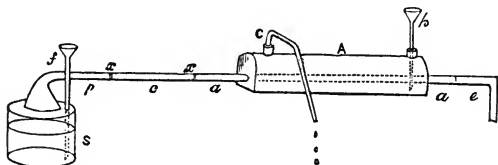

239.

funnel that reaches nearly to the bottom of the still, *p*, *c*, *a*, *e*, is a block-tin pipe with joints at *x* and *x* and between *a* and *e*. The joint at *x* between *p* and *c* is not essential. *A* is a janned case of zinc or tinplate in which the tube *a*, *a*, is soldered air-tight. This case is kept always full of cold water, the water being run in continuously by the funnel *h*, and as continuously run off in a warm state by the waste pipe *c*.

The cold water is supplied from a bottle, figure 240, so placed that the water from the cock *c* runs immediately into the funnel *h*. A pail is placed to receive the warm water that runs from the waste pipe *c*.—The still *S* is placed over a common kitchen or parlour fire, in order to obtain heat economically. The condenser *A* must be supported by a stool, or a pile of bricks. When the water boils down below the end of the funnel *f*, steam issues from the funnel and gives notice that more water is required; but the still should never be more than half full, lest the impure water should boil over.—The distilled water escapes by the bent pipe *e*, where a

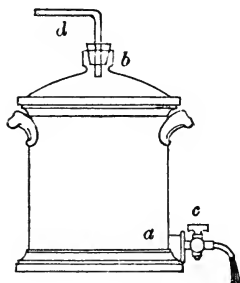

240.

bottle is placed to receive it. With this still, 4 quarts of distilled water can be prepared in 3 hours. At the end of the operation, all the vessels should be immediately emptied, the still washed out, and the whole be dried. This still should never be used for anything but the distillation of water.

A still of this form is often made with a loose head, to afford the opportunity of cleaning it inside. When the still is used to distil any other liquid than water, it is indispensable to have a loose head, otherwise the operator would never be sure of procuring pure water, even by distillation. See the description of figure 242.

The apparatus, represented by figure 241 is a much older form of distilling apparatus, and is still greatly in use; being no doubt recom-

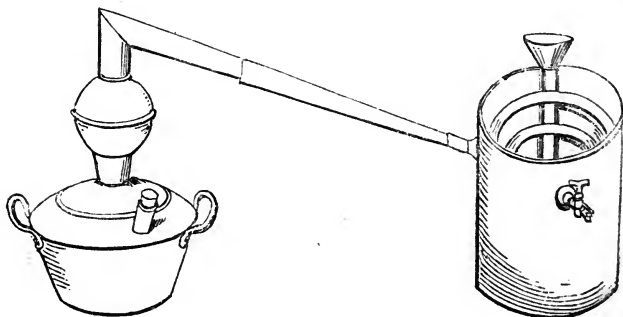

241.

mended by its antiquity. It consists of a still and worm tub. The distilled water escapes by a pipe which is not shown in the cut. This kind of apparatus is often made of such relative proportions

that the still packs into the worm tub for the sake of portability in travelling. This form of distilling apparatus is commonly used by travelling photographers. A defect it has is, that you cannot clean the inside either of the still or the condenser.

The following apparatus is more powerful than the foregoing, and applicable, not only to the distillation of water, but to that of alcohol

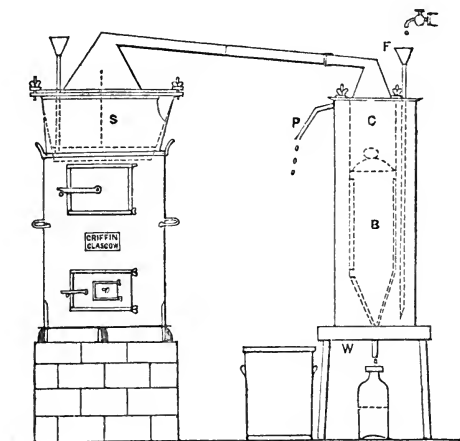

242.

and all kinds of volatile oils. It presents the great advantage over many forms of distilling apparatus, that every part of the interior of it can be readily got at for the purpose of thorough cleaning. The still S has nearly the same shape as that described above. It has, however, a moveable head, which can be fastened on by 4 screw-nuts, a washer of many folds of filtering paper being placed on a broad flange between the head and the still. There is also a moveable pierced false bottom, which is only used in the distillation of volatile oils, the use of it being to prevent rose leaves, &c., from touching the bottom of the still, to sodden in the water, or to suffer from burning. The heat is afforded by a portable furnace fed with charcoal. An iron jacket is put upon the furnace round the still, to prevent the loss of heat by radiation. The carbonic acid of the fire escapes by a large hole in the upper part of this jacket.

The condenser consists of a hollow cylindrical body, the two concentric walls of which form a space that is kept continually full of cold water. This is supplied from a water bottle by the funnel, F, and the warm water flows away by the waste pipe, P. The head of the

condenser is separate from the body, and fastened on by screw-nuts in the same manner as the head of the still. The steam passes from the still directly into the cavity, C, of the condenser, where it is in contact with the cold water of the circular cistern, close against which it is pressed by the solid block, B, which allows only $\frac{1}{4}$ inch of space all round for the steam to pass by; and as the steam comes here into contact with the coldest water issuing continually from the lower end of the funnel, F, it is effectually condensed, and flows out of the pipe, W, in the state of water more or less warm according to the more or less effective state of the condensing power. In adjusting the apparatus for use, the condenser is first mounted on a three-legged stool, having a hole in the centre of the top for the reception of the delivering pipe, W. The furnace is then brought to a proper level by means of a stack of loose bricks.

With this apparatus several gallons of distilled water may be prepared in a day. When a distillation is ended, all the vessels should be emptied, washed and dried without delay, otherwise the still and condenser, both of which are made of tinned iron, will become rusty. The outside of the condenser may be japanned. An apparatus of this form, consisting of a copper still and a block-tin condenser, may be used in pharmacy, and for a variety of important distillations. It gives purer water than a similar apparatus made from tinplate, principally because the solder used for the joints of tinplate vessels contains lead, which steam dissolves. As, however, a very small surface of solder is presented to the steam in a well-made apparatus of this kind, the impurity thence arising is commonly of no importance. A *new* tinplate still and condenser is always soiled by resin about the joints, which must be washed off with warm spirit of wine applied with a rag, otherwise the distilled water produced will be muddy and smell of resin.

While describing the process of distillation, I may briefly notice a few pieces of apparatus which properly belong to that operation, though not necessary, when water only is distilled.

Figure 243 represents a distilling apparatus, including what is popularly called Liebig's condenser. This condenser consists of a glass tube of the form of figure 244, and which in the apparatus, figure 243, is marked *a a*. *b* is a metal jacket which surrounds the condenser tube in order to keep it imbedded in cold water. The tube *a a* is fastened to *b*, by indian rubber tubes passing over two small necks that are soldered to the tube *b*. *c* is a funnel by which cold water is supplied continuously from the water-bottle, *h*, mounted on a stool at the proper height. *d* is an overflow pipe by which the condensing water, after being warmed, runs off into the pan, *i*. *e* is a retort in which the vapour is produced by the heat of the triple Bunsen's gas burner, *k*. This glass condenser is suitable for the distillation of all descriptions of

volatile liquids—water, spirits, acids, &c. *f*, is an adapter shown apart in figure 245. The use of this is to convey the distilled liquor con-

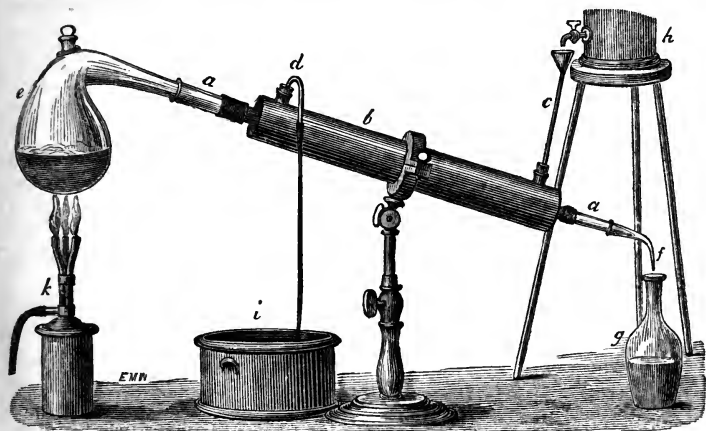

243.

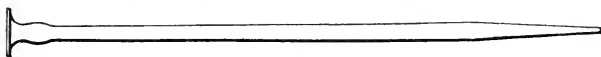

244.

veniently into the vessel that is destined to receive it, as is shown by two examples in figures 246 and 247.



245.

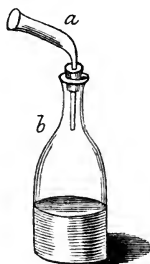

246.

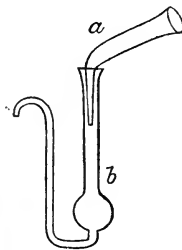

247.

The condenser and its appendages, as shown in figure 243, are supported by a stand which has a universal joint and a sliding pillar. By this means the condenser can be raised to any desired height, and inclined at any desired angle, to suit either the heating or the cooling part of the apparatus.

Figure 248 represents another distilling apparatus, the general arrangement of which so far resembles that of the apparatus represented by figure 243, that only a brief description of it will be necessary.

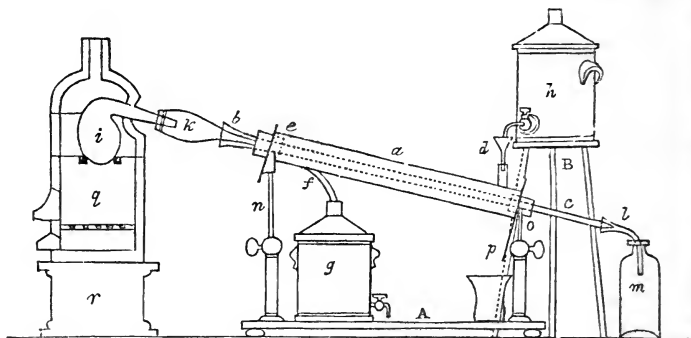

248.

In this example, the condenser case is of large dimensions in order to contain a considerable body of water, to render the condensation perfectly effective when it is desirable to lose no portion of the distilled liquor. *a* is the condenser case, made in a triangular form; *b*, *c*, the glass condenser tube; *d*, the funnel to receive the supply of cold water; *e*, a flat metal flange to secure the condenser on its support, there is one at each end; *f*, the escape pipe for the warmed condensing water; this water is collected in the water-bottle *g*, which, when the water is cold, can be put in the position of the bottle *h*, and the water be used again. The water-bottle *h* stands on a stool, *B*. *i* is a retort, supported on two iron bars in a furnace, *q*; *k* is an adapter, to connect the retort with the condenser; *l*, a small adapter, to connect the condenser with the receiving bottle, *m*; *A* is the condenser stand, having two sliding pillars, *n* and *o*, which can be raised to any required height. The flange *p* serves to collect any waste water or overflow from the funnel *d*, and carry it into a beaker instead of permitting it the chance of flowing over the pipe *c*, and contaminating the liquor in the bottle *m*. *r* represents a stoneware support for the furnace, to prevent its burning the table. No caoutchouc connectors are represented in this figure because it was drawn and engraved before their invention.

Florentine Receiver.—When volatile oils are distilled with water, the distilled liquor, on being allowed to cool and settle, throws a quantity of the oil to its surface, but retains as much as it can hold in solution. Thus, when rose leaves are distilled with water, the distilled liquor is a saturated solution of rose oil in water; while the superabundant oil rises to the surface of the cooled rose water. The Florentine receiver

is a contrivance employed for separating the oil from the water in such distillations. Three varieties of that apparatus are shown by figures 247, 249, 250. These are all so contrived that the oil gradually rises in the wide part of the vessel, while the water sinking downward, flows away by the syphon neck into a suitable vessel placed to receive it.



249.

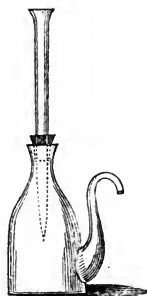

250.

THE STILL WATCHER.

In the distillation of spirits, and particularly of the spirituous compounds that are employed in pharmacy, it is often important to have the distilled liquor of a determinate strength. But as, when any mixture of spirits and water is distilled, the strong spirit comes over first, and afterwards a liquor that is progressively weaker and weaker in spirits; it sometimes happens that the distillation is carried too far, and the whole mixture is made too weak. To prevent this accident, Dr. Mohr has contrived the apparatus represented by figure 251. Excepting the foot, it is entirely formed of glass. *a* is an adapter connected with the end of a Liebig's condenser. The distilled liquor passes from the adapter into the funnel, and rising in the cylinder, escapes by the tube *c*. In the cylinder it meets with a small glass hydrometer, the scale of which is graduated to suit the liquor, the distillation of which has to be watched, say from $\cdot 79$ to $\cdot 85$ if for spirits, or any other required scale. The stronger the spirits in the cylinder, the lower this hydrometer sinks in the liquor: as the proportion of water increases, the spindle rises, and thus the still watcher gives notice of what is going on, and enables the distiller to change his recipient and collect products of definite desirable strength.

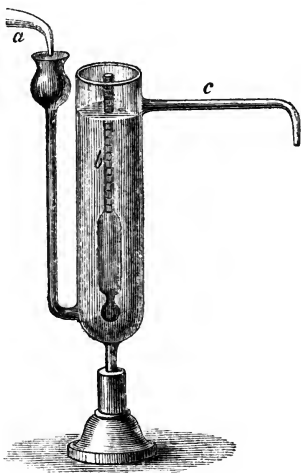

251.

Tests of the Purity of Distilled Water.—It must be transparent and colourless; it must not smell or taste of burnt oil; it must not change the colour of red or blue litmus paper. When slowly evaporated to dryness in a platinum or glass capsule, it must leave no solid residue. It must not become turbid when tested separately with solutions of nitrate of silver, nitrate of barytes, and oxalate of ammonia.

PEROXIDE OF HYDROGEN. OXYGENATED WATER.

Symbol, HO; Equivalent, 17; Systematic name, Hydrate

This compound is formed by dissolving peroxide of barium in hydrochloric acid.

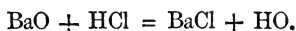

The compound HO remains in solution.

Hydrated sulphuric acid is next added, when the mixture deposits sulphate of barytes, and leaves free hydrochloric acid again in solution in company with the peroxide of hydrogen.

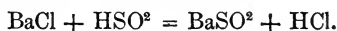

More peroxide of barium is now added, and the process is repeated many times, the sulphate of barytes being separated by filtration. Finally, the hydrochloric acid is separated by means of sulphate of silver, and sulphuric acid by means of carbonate of barytes. Many precautions are required to insure success. They are described in detail in the *Traité de Chimie, par Thenard*, tom. ii. p. 42; Paris, 1827. Ultimately, we obtain a solution of the compound HO, which at its greatest density is a colourless liquid of the specific gravity of 1.453.

It has an extremely slight odour, similar to that of chlorine. Its taste is harsh and bitter. It whitens the tongue, thickens the saliva, and destroys sensation for a time. If a strong solution is placed on the hand, it burns the skin, producing a white mark, and after a time, a violent itching. If a weak solution is rubbed on the hands, they acquire the same odour as if they had been rubbed with a solution of chloride of lime. In vacuo, the solution evaporates without decomposition. It cannot be rendered gaseous by heat, which decomposes it, nor can it be solidified.

As its preparation is very troublesome and expensive, and it cannot be preserved for any length of time, it has not been often prepared or examined. It possesses powerful bleaching properties, and some other characters similar to those which are manifested by solutions containing chlorine in a bleaching state. Its analysis shows it to contain one part of hydrogen combined with sixteen parts of oxygen by weight.

The usual theoretical explanation of this compound is, that it is

either a combination of water with oxygen, or else a compound of one atom of hydrogen with two atoms of oxygen. According to the radical theory, it has the simpler constitution shown by the formula HO, water being a salt in which hydrogen is combined with this oxide of hydrogen, = H + HO. All the reactions in which this curious compound takes part agree completely with this view of its constitution, and I am inclined to consider it to be one of the most active and energetic compounds with which chemistry makes us acquainted.

Certain substances decompose it promptly into water and oxygen.

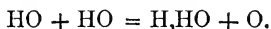

In this case, as in all cases when water is to be produced by the decomposition of another compound, as much decomposition must occur as will give the two atoms of hydrogen which are necessary to form a single atom of water. (See page 154.) Consequently, the formation of an atom of water is attended by the liberation of an atom of oxygen. This occurrence has been erroneously considered by some chemists to prove that peroxide of hydrogen is composed of water and oxygen. That inference rests on no better grounds than the similar inference that water is contained in caustic potash, in oil of vitriol, &c., because it is produced when those compounds are decomposed. Rejecting that notion, and assuming the peroxide of hydrogen to be formed according to the formula HO, we have a key to the solution of many curious chemical problems, as will appear in the course of our subsequent investigations.

The following reactions agree perfectly with the composition here ascribed to oxygenated water:—

a.) When peroxide of hydrogen is mixed with sulphurous acid, the odour of both instantly departs, even when much water is present, and hydrated sulphuric acid is formed.



b.) Oxygenated water mixed with hydriodic acid produces water and free iodine.

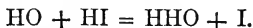

c.) When peroxide of hydrogen is mixed with a solution of sulphuretted hydrogen, both are slowly decomposed, the mixture becomes milky, and finally produces water and a deposit of sulphur, with scarcely a trace of sulphuric acid.



d.) Oxygenated water, which is easily decomposable when in solution in pure water, becomes much more stable when in combination with hydrated acids. Thus,

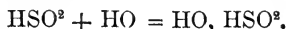

These four experiments are given by Thenard. Schönbein has lately described some experiments that accord with that marked *d*. Several peroxides, namely, dissolve in cold and concentrated hydrated acids, and produce solutions which manifest some of the most striking of the properties of oxygenated water; they bleach indigo tincture with the energy of chlorine liquors; they oxidise many metals in the cold, and like ozone, they give a blue colour to starch containing iodide of potassium. All the peroxides thus combined with hydrated acids are reduced by the addition of oxygenated water to the condition of basic oxides, while the oxygenated water is reduced to common water and oxygen.

These reactions, though ascribed by Schönbein to the antagonistic reactions of *ozone* and *antozone*, as will be explained in the next section, are easily explained in accordance with the radical theory, and the assumption that oxygenated water is HO. Thus, assuming M to be the metal of a peroxide, we have the following two decompositions:

In the first stage,

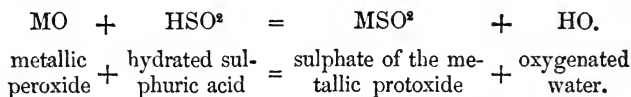

And in the second stage (after the oxygenated water is added),

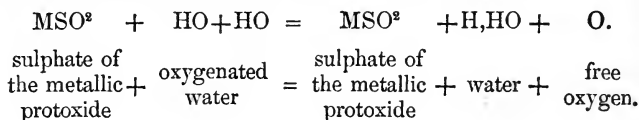

Among the salts which act in this manner, Schönbein enumerates the following:—Peroxide of manganese in acetic acid or in hydrochloric acid; peroxide of lead in acetic acid; and peroxide of silver in nitric acid.

If the formula HO, which I have assigned to this oxide of hydrogen, expresses its true composition, then the two names by which it is usually designated—oxygenated water, and peroxide of hydrogen—are equally improper. The term *Hydrate*, signifying one atom each of hydrogen and oxygen, is accurate and precise.

OZONE.

Symbol, HO³; *Equivalent*, 33; *Systematic Name*, *Hydrete*.

Admitting the formula HO³ to represent the true constitution of ozone, we have the following series of oxides of hydrogen:—

	Usual Names.	Systematic Names.
H,HO	= Water	Hydra hydrate.
HO	= Oxygenated water	Hydrate.
HOO	= Ozone	Hydrete.

This series corresponds with the series of the Oxides of Nitrogen :

	Usual Names.	Systematic Names.
N,NO	= Nitrous oxide	Nitra nitrate.
NO	= Nitric oxide	Nitrate.
NOO	= Peroxide of nitrogen	Nitrete.

No reason can be given why this parallelism should not occur. I shall endeavour to show that it does occur.

In opposition to this doctrine, that ozone is an oxide of hydrogen, comes the doctrine, that ozone contains nothing but oxygen, that it is allotropic or *active* oxygen, entirely free from hydrogen. This is a curious and important question. Let us examine the experimental evidence, and form a judgment upon the facts, whether ozone is best entitled to be considered an element or a compound. Debateable questions such as this are worth the attention of the inquiring student. We are accustomed to laugh at the fantastic notions and the false reasoning of the alchemists, but we sometimes ride our modern chemical hobbies as unskilfully as they did the wild hobbies of the middle ages. It is good, therefore, for the young chemist not to be over-credulous, but to cross-question, with constant and unflinching logic, the speculations with which all new facts are commonly amalgamated.

Preparation of Ozone.—1. Its odour is recognised in the vicinity of an electrical machine when in active operation. 2. It is particularly evident near a Ruhmkorff's Induction Coil, when in good action. In a small room, at the end of an hour, it becomes unpleasantly powerful. 3. It is produced during the electrolysis of water, but only when particular acids are present. The mixed gases produced by the electrolysis of water smell of it. When the two gases are collected apart only the oxygen gas smells of it.

4. Take a piece of phosphorus about half an inch long, clean its surface by scraping, put it into a clean two-quart glass bottle, add as much water as covers the phosphorus half way, close the bottle with a loose stopper, and set it aside at a temperature of about 60° F. Ozone will soon begin to form in the air of the bottle, and in five or six hours it will be abundant. Remove the phosphorus, shake a little water in the bottle, and throw that out to remove the phosphoric acid. Repeat this washing several times; the ozone is not washed away with the water, but remains in the air of the bottle.

5. Put a little ether into a wide bottle, and shake it about to form an atmosphere of ether. Heat a glass rod or a platinum spiral in a spirit-lamp flame, and plunge it, while moderately hot, into the ether

vapour, which immediately becomes ozonised. The rod must not be too hot, or the ozone will be destroyed as soon as formed.

6. It is stated, in many chemical books, that pure dry oxygen gas, confined in a glass tube, and submitted to a constant succession of electric sparks, is entirely converted into ozone. The accuracy of this statement will be examined in a subsequent paragraph.

7. When a narrow glass tube open at one end is filled with oxygen and placed in communication with an aqueous solution of iodide of potassium, and a current of electric sparks is passed through the oxygen for several hours, the oxygen gradually disappears, and the solution rises into the tube, and ultimately fills it, while iodine is separated.

Tests of the presence of Ozone.—1. Take one part of pure iodide of potassium, ten parts of starch, and 200 parts of water; boil the mixture for a few minutes. Spread the paste so formed on the surface of hard-sized paper. Dry the papers, and cut them into slips, which must be preserved from the action of the air. This paper is *Schönbein's Ozonometric Test*. When moistened and placed in an atmosphere containing ozone it instantly becomes blue. If exposed dry to such an atmosphere, and then removed and moistened, it also becomes blue.

2. Paper soaked in a weak solution of sulphate of manganese becomes brown when exposed to an ozonised atmosphere.

3. Paper stained black with sulphide of lead becomes white when exposed to ozone.

4. A dilute solution of blue sulphate of indigo is bleached if poured into a bottle containing ozone.

5. If a sheet of silver foil is put into a bottle of ozone, in four or five hours it crumbles into dust, which consists of peroxide of silver.

6. Freshly prepared spirituous tincture of guaiacum is turned blue when exposed to an atmosphere of ozone. To make this tincture, 1 part of guaiacum resin is dissolved in 30 parts of strong alcohol, and the solution is afterwards considerably diluted with spirits of wine.

Properties of Ozone.—It is a gaseous body possessed of a very peculiar odour, approaching to that of chlorine. The power of this odour is such that one part of ozone is perceptible in a million parts of atmospheric air. It is diffusible in atmospheric air or in oxygen gas. The extent to which oxygen can be saturated with ozone is not accurately known. By the electrolysis of water containing $\frac{1}{10}$ of sulphuric acid Baumert found only 1 milligramme of ozone in 150 litres of explosive gas. Andrews found that when water was mixed with $\frac{1}{4}$ of sulphuric acid the oxygen separated from the hydrogen contained 4 milligrammes of ozone in 1 litre of gas; and he states that with a solution containing $\frac{1}{2}$ sulphuric acid 8 milligrammes of ozone may be condensed in 1 litre of oxygen. That is the highest published estimate, and it is equal to 1 part of ozone in 180 parts of pure oxygen. Ozone cannot be separated from oxygen or reduced to the liquid or the solid state.

It is insoluble in water and in solutions of acids and alcalies. In these properties ozone differs essentially from oxygenated water, which is odourless, and is not diffusible in air, while it is easily soluble in water and in hydrated acids.

Ozone possesses powerful bleaching properties and acts corrosively on many organic matters, even on cork and vulcanised caoutchouc. It converts metallic silver into peroxide of silver. It possesses the power of deodorisation, so that if a piece of tainted meat is immersed into it the ill odour is rapidly destroyed. It is easily destroyed by heat; so that if ozonised oxygen is passed through a red hot tube only common oxygen remains.

In addition to these properties of ozone, I may call attention to the probability that it is, in all cases hitherto described, a solution or diffusion, in an atmosphere of oxygen, or of common air, of a compound constituted in accordance with the formula HOO, and that this diffusion takes place, like that of aqueous vapour, in quantities which accord with certain fixed relations of temperature, pressure, and other physical characteristics;—relations which, as respects aqueous vapour, are well known, but, as respects ozone, have yet to be determined.

The "active" substance at work through all the intricacies of the ozone reactions seems to me to be the compound HO, which consists of one atom of hydrogen = 1, and one atom of oxygen = 16. This compound HO is the so-called oxygenated water, or peroxide of hydrogen. When combined with another atom of hydrogen, HO produces water = H,HO. When combined with another atom of oxygen, HO constitutes ozone = HOO. The activity of the oxidising power of ozone depends upon the facility with which HOO exchanges O¹ for H¹, and thus produces the bland, mild, neutral, inactive water.

This "active" compound HO it is which, in combination with a basylous metal, produces an alcali: $K + HO = KHO$, caustic potash. This compound it is which, in combination with oxidised acid radicals, produces the hydrated acids:—

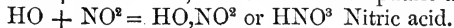
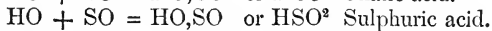

This same active compound it is which, when rendered stable by combination with neutral salts, possesses the power of bleaching. You add chlorine to hydrate of lime, and you produce bleaching powder:—

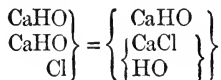

When this salt *bleaches* it takes up hydrogen, and the whole falls into water, chloride of calcium, and hydrate of lime.

According to this theory, all the affections of vegetable colours depend upon this active compound HO. It is the colouring agent of the alkalies; it is the colouring agent of the acids; it is the discolouring agent of the bleaching salts. In other words, it is the power which effects the transference of the atoms of oxygen and hydrogen which are demanded by the several decompositions, the occurrence of which is made evident to sight by these changes of colour.

Examination of some of the Theories respecting Ozone.—Ozone was discovered by Professor Schönbein of Basle in the year 1840. Since then a great many papers have been published by him and other philosophers narrating a variety of experimental researches into the properties and composition of ozone. Very lately (see Liebig's *Annalen der Chemie*, November, 1858), Schönbein has published a series of experiments, from which he concludes that there are no less than *three kinds of oxygen*; namely, COMMON OXYGEN, or oxygen in an *inactive* state; secondly, OZONE, or oxygen in a state which he calls *positively active*; and thirdly, ANTOZONE, or oxygen in a state which he calls *negatively active*. When these two kinds of active oxygen combine with one another, equivalent to equivalent, they constitute common inactive oxygen.

Upon this foundation he builds two classes of metallic oxides, the Ozonides and the Antozonides.

The *Ozonides* are the superoxides of Mn, Pb, Ni, Co, Bi, Ag, also the compounds called Chromic, Permanganic, and Vanadic acids.

The ozonides are said to possess these properties: 1. When treated with hydrochloric acid, they produce chlorides, free chlorine, and water. 2. They do not combine with hydrated acids. 3. They decompose oxygenated water into water and oxygen. 4. They give a blue colour to freshly-prepared tincture of guaiacum. 5. They are strongly electro-negative.

The *Antozonides* are the superoxides of Ba, Sr, Ca, and of the metal of the alkalies.

They have these properties: 1. When treated with hydrochloric acid, they produce chlorides and oxygenated water. They do not discharge free chlorine from chlorides. 2. They combine with hydrated acids. 3. They do not decompose oxygenated water into water and oxygen. 4. They do not give a blue colour to tincture of guaiacum on the contrary, they bleach that which has been made blue by the ozonides. 5. They are electro-positive.

A consideration of the reactions of the ozonides and the antozonides and of oxygenated water with ozone, gives occasion to this philosopher to advance the hypothesis that chlorine is not an element, but a compound. Hence, we are to be led to believe, that ozone is an element by first being taught that chlorine is a compound. These remarkable hypotheses seem to have commanded the advocacy of Professor Faraday.

Schönbein gives pictorial symbols to the two active oxygens; but not having suitable types to print them, I shall indicate Ozone, or positively active oxygen, by O_p^a ; and Antozone, or negatively active oxygen, by O_n^a .

Compounds depicted in accordance with the Theory of Ozone and Antozone.

Oxygenated water	=	$HO O_p^a$
Murium superoxide (chlorine)	=	$MuO O_n^a$
Muriatic acid	=	MuO, HO
Peroxide of barium	=	$BaO O_p^a$
Peroxide of manganese	=	$MnO O_n^a$

In comparing the following equations, the reader will observe, that O in Schönbein's formulæ signifies 8, and in mine it signifies 16 parts of Oxygen.

Schönbein finds that when a given quantity of oxygenated water is shaken in a bottle with a sufficient quantity of ozonised oxygen, the odour of the ozone disappears, the oxygenated water becomes common water, and the ozonised oxygen becomes common oxygen. This he explains as follows:—

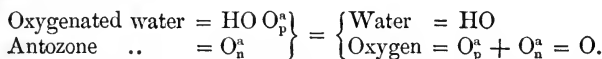

This signifies that oxygenated water is composed of common water and ozone, and that when to this compound you add antozone, the ozone leaves the water to combine with the antozone, and produce common oxygen.

Now, on the radical theory, and on the assumption that oxygenated water is HO , and that ozone is HO^2 , this reaction is explained as follows:—

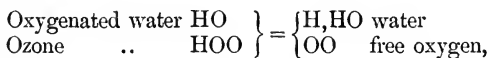

namely, an atom of water is produced, and the residue of oxygen is set free. No benefit is derived from the assumption that three different kinds of oxygen are concerned in this simple operation.

Schönbein finds that when peroxide of barium and muriatic acid meet together, the reaction is as follows:—

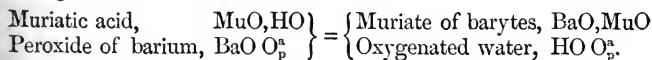

On the radical theory the reaction is simply this:

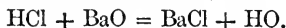

Nothing is gained by the twofold assumption,

a). That chlorine is a peroxide of murium; and

b). That two kinds of oxygen are concerned in this experiment.

Schönbein considers that when muriatic acid acts upon peroxide of manganese, the transposition of atoms takes place as follows:

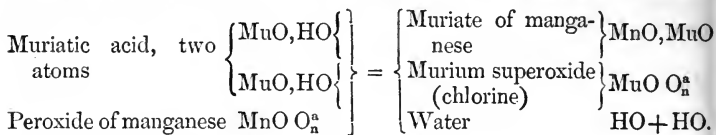

On the radical theory the reaction is explained thus:

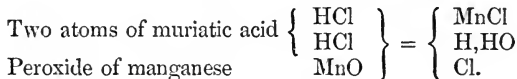

Here again the explanation on the radical theory is so simple and satisfactory, that the new hypotheses are perfectly needless, and serve only to introduce detrimental complications.

Why do the ozonides and antozonides act differently with hydrochloric acid? Schönbein thinks he explains the cause of the difference of action by attributing it, in the one case to the presence of ozone, and in the other to the presence of antozone. But, we may ask, why does ozone always combine with barium, and never with manganese? Why does antozone always combine with manganese, and never with barium? Why are the peroxides produced in two such distinct sets? The only reply to that question must necessarily be, that the *inherent powers* of ozone and antozone determine these results. Unluckily, however, for the acceptability of such a conclusion, it appears to be quite as easy to attribute all differences in the reactions of the ozonides and antozonides to a difference in the inherent power, not of their oxygen, but of their *metallic radicals*. There is evidently "something" which causes a difference in the reactions. If that "something" exists in the metals, and not in the oxygen, there is an end to the necessity of inventing these varieties of antagonistic oxygen. The ascription of a compound constitution to chlorine seems to be especially bootless. It is true that one volume of chlorine, which weighs 35.5 may contain two volumes of oxygen weighing 32, and a murium radical weighing 3.5; but sound logic requires us to withhold credence from the belief in such a radical, until either it or oxygen has been separated from chlorine. The experiments and arguments now adduced by Schönbein certainly fail to carry conviction on that point to an unprejudiced mind. We must continue to believe in the elementary nature of chlorine till we can get out of chlorine something that is not chlorine. We must continue to ascribe peculiar and inherent powers to barium and manganese as long as we find those metals possessing powers and reactions which individualise them under all kinds of reactions. Nothing is gained by attaching the idea of these differences in power to

varieties in the oxygen instead of varieties in the metals. By so doing, we only contrive a necessity for using new words to describe old knowledge, and that with less clearness than it was already described by old words.

I proceed to notice a few miscellaneous experiments, and the theories which depend upon their teachings.

Schönbein refers to the following experiment as affording proof of the accuracy of his theory: five parts of peroxide of barium, and two parts of peroxide of manganese, produce, with muriatic acid, chloride of barium, chloride of manganese, and free oxygen, but no chlorine, as might, he considers, have been expected in the presence of peroxide of manganese.

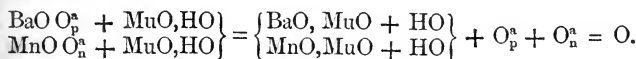

On the radical theory the explanation is as follows:—

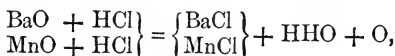

consequently, the assumption, that the disengaged oxygen is a product of the combination of O_p^a with O_n^a is quite unnecessary, as is also the notion that the salts produced are muriates and not chlorides.

According to the preparation of ozone, No. 6 in the above list, *dry oxygen* can be converted into *ozone*. This is a fundamental point in the oxygen theory. But Baumert found that when oxygen was electrified with an induction coil, at the rate of five hundred thousand sparks in an hour, the product of that enormous exertion of power continued for an hour was only as much ozone as separated one milligramme of iodine from a solution of iodide of potassium.

Now, on the radical theory, and on the supposition that ozone is HO^3 , the decomposition which occurs in KI is as follows:—

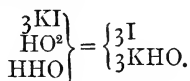

That is to say, three atoms of iodide of potassium, one atom of ozone, and one of water, produce three atoms of free iodine and three of caustic potash. This shows us what is the proportion of hydrogen in the ozone. The atomic weight of iodine is 127; that of hydrogen is 1. 3 times 127 = 381. To liberate 381 grains of iodine, therefore, requires as much ozone as contains one grain of hydrogen. Hence, to liberate one milligramme of iodine, which is the 0.0154 part of a grain, as much ozone is required as contains the 381st part of the 0.0154th part = 0.00004, of a grain of hydrogen.

In some of the analytical experiments of this description, the solution

of iodide of potassium was mixed with hydrochloric acid, to prevent the formation of iodate of potash. The decomposition then occurred thus:—

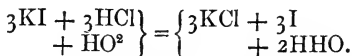

In this case, as above, the liberation of 3 atoms of iodine = $3 + 127 = 381$ grains, demands the addition of 33 grains of HO^2 , containing one grain of hydrogen. This process will be referred to in another paragraph, which describes the experiments of Professor Andrews.

The above experiments do not prove that ozone is formed by dry oxygen; the result is nullified by the possibility of the presence of hydrogen in quantity too small for experimental detection, but large enough to disrupt the dry oxygen theory.

Messrs. Fremy and Becquerel electrified pure dry oxygen sealed in glass tubes, by means of a frictional electrical machine which gave sparks at the rate of four to eight per second for six hours. The tubes were then opened in a solution of iodide of potassium, and the absorption of the ozone was noticed. In one experiment, the solution filled the tube; in two others, it filled only one-third part of the tube. The size of these tubes was $\frac{1}{10}$ millimetre in bore, and 30 millimetres in length, that is to say, they were as wide as the thickness, and as long as the length of the following black mark: 

This was the most important experiment that had been made to prove the possibility of *converting pure dry oxygen entirely into ozone*; it was repeated three times, but it is rash to come to the conclusion that this object has been achieved, from three experiments, of which two failed, and the best of which presents numerous reasons for doubt. How was it possible, for example, to ascertain that a quantity of oxygen no larger than the above black mark, did not contain a column of hydrogen as wide as the mark, and having from $\frac{1}{3}$ to $\frac{1}{9}$ of its length?

The seventh preparation of ozone deserves our especial attention, because it is a process which is always successful. Oxygen gas electrified in connection with an aqueous solution of iodide of potassium is entirely absorbed by that solution, under separation of iodine. The reason of the success is, that vapour of water rises into the oxygen gas, and affords the hydrogen which is required for the formation of ozone.

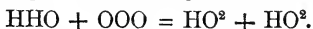

When hydrogen is present as well as oxygen, ozone is readily made, either by electrical or chemical means; but in the absence of hydrogen, the utmost difficulty occurs. Why is this so? If ozone is only oxygen, why is the presence of hydrogen so helpful, if not so indispensable, to its formation?

Ozone is readily formed by phosphorus in the presence of oxygen and water (see preparation No. 4.); but dry phosphorus in dry oxygen

does not produce ozone. It does not even become phosphorescent. This is intelligible on the supposition that ozone contains hydrogen, but not otherwise.

The following is one of Professor Schönbein's quantitative experiments on ozone. The air of two sulphuric acid carboys being ozonised, was passed through a solution of five grammes of yellow prussiate of potash, which it converted into red prussiate of potash. This experiment is perfectly in accordance with the assumption that ozone contains hydrogen. The constitution of the two prussiates of potash agree, on the radical theory, with the following formulæ:—

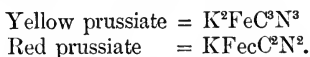

Two atoms of the yellow prussiate, weighing 368 grains, produce three atoms of the red prussiate, weighing 329 grains, under separation of one atom of potassium, weighing 39 grains, the latter requiring HO, weighing 17 grains, to convert it into caustic potash. Thus:

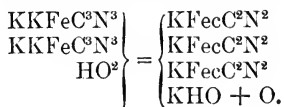

In this case, the two ferrous atoms are converted by the *so-called*, and erroneously so-called, *oxidising* action of the ozone, into three ferric atoms. The quantity of hydrogen which comes into play here is one grain upon 368 grains of yellow prussiate. The proportion for five grammes, or 77 grains, is about one-fifth of a grain of hydrogen. We have, on the one hand, no evidence that the great mass of air which filled two carboys did not contain this one-fifth part of a grain of hydrogen. We have, on the other hand, absolute chemical certainty that the conversion of the yellow prussiate of potash into the red prussiate would not take place unless an acid radical was provided to neutralise the liberated atom of potassium. Oxygen alone would not suffice. In the absence of a metalloid, hydrogen serves the purpose.

I must qualify the above explanation by pointing out that the conversion of the yellow prussiate of potash into the red prussiate, requires not ozone = HO², but what is called oxygenated water = HO. But, probably, either of these compounds will answer the purpose; the superfluous oxygen of the ozone, when that is brought into play, passing off with the great mass of oxygen with which it is accompanied.

But we may farther ask, how comes it to pass that the air of two sulphuric acid carboys has only so much "oxidising" power as is equivalent to the one-fifth part of an atom, either of H or HO²? The size of the carboys is not given, but if we assume them to be of ordinary capacity, such as would contain about 80 lbs. of water, then

they would each contain about 2200 cubic inches of air, the fifth part of which being oxygen, would represent 150 grains of oxygen, or in the two carboys 300 grains. Yet these 300 grains of oxygen, after being exalted to the condition of ozone, act chemically merely as the equivalent of $\frac{3}{8}$ grains of HO^2 . That is a very remarkable fact. If ozone is really ozonised oxygen, what is it that limits the ozonising power to one part of oxygen in from 100 to 400 parts? Why does the action not continue till the whole of the oxygen is ozonised? Perhaps, as nature was formerly said to abhor a vacuum, she may now be said to abhor a thoroughly-ozonised atmosphere, and therefore she permits the ozonisation to act only within prescribed limits—a quarter per cent. or so. But that is only in the presence of dry oxygen. Nature sets no limit to the ozonisation of oxygen, and does the work without difficulty or loss of time when she is allowed sufficient hydrogen with which to do the work. That is the true course of action. When you reverse it—when you set Nature to make ozone without hydrogen—you resemble the Egyptians, who set the children of Israel to make bricks without straw.

An elaborate series of experiments on the constitution of ozone have been published by Professor Andrews (see *Philosophical Transactions*, 1856, i. 3; and *Journal of the Chemical Society*, ix. 168). They appear to have been made with great care, and he draws from them the conclusion, that ozone is not a compound body, but oxygen in an altered or allotropic condition. I do not agree with his conclusion, because his experiments, however carefully performed, are not of a nature to establish beyond contest a doctrine so important.

Dr. Andrews's method was to pass electrolytic oxygen, of the strength of four milligrammes of ozone in a litre, through a solution of iodide of potassium mixed with hydrochloric acid. He ascertained the increase of weight of the recipients of the ozone, which gave the amount of the ozone. He then tested the free iodine by a solution of sulphurous acid, supplied from a centigrade test tube; and comparing the weight of the iodine with the increase of weight of the apparatus and its contents, he found the *average* result to be

For 127 iodine, 8 oxygen.

This method required a multitude of weighings and measurements, and testings and reckonings, which of course gave just so many chances of error; and all the errors incident to so complicated a process had to be reckoned upon infinitely small quantities of matter. In five experiments, which in the whole consumed 29 litres of electrolytic oxygen, the greatest quantity of ozone collected for weighing was less than three-fifths of a grain, the smallest quantity was less than one-sixth of a grain.

I have shown at page 253, that if ozone is HO^2 , the acting quantity in a reaction of this kind is 33 grains against 381 grains of iodine, or,

For 127 iodine, 11 ozone.

This differs, indeed, from Dr. Andrews's *average* result; but, accepting his experiments as free from errors, his individual results are also discordant. Thus, in five experiments, the iodine being fixed at 127, and the oxygen reckoned at 8, the ozone found by weighing, was,

	+	-
No. 1.	7.85	0.15
2.	8.56	0.56
3.	8.93	0.93
4.	8.20	0.20
5.	7.36	0.64

Between Nos. 5 and 3 there is a very important difference, as shown by the following equation:

$$736 : 893 = 8 : 9.71.$$

This difference is quite sufficient to show that the question respecting the elementary or compound nature of ozone cannot be held to be settled by this series of experiments.

As ozone, HO^2 , contains only one part of hydrogen in 33, as ozonised oxygen usually contains only about one part of ozone in 400, and as common air contains only one-fifth of oxygen, it follows that ozonised air will contain about one part of hydrogen in 66000 parts of air. In that air, we can smell the ozone, and we can witness the exertion of its surprising chemical energy; yet we cannot detect its hydrogen. Our experimental powers fail—our tests are too coarse. The difficulty of determining whether ozone is an element or a compound, depends upon the fact, that the quantity of acting matter is so infinitely small—is in so homœopathic a dose—that it cannot be caught or confined, to be weighed, or measured, or analysed, with *certainty*. Yet the majority of the reactions seem to show clearly that ozone is not oxygen, but an oxide of hydrogen.

SECOND NOTE ON OZONE. By Thomas Andrews, M.D., F.R.S., and P. G. Tait, M.A., F.C.P.S. *Read before the Royal Society, Jan. 20, 1859.*

“The commonly-received statement, that the whole of a given volume of dry oxygen gas, contained alone in an hermetically-sealed tube, can be converted into ozone by the passage of electrical sparks, is erroneous. In repeated trials, with tubes of every form and size, the authors found that not more than $\frac{1}{100}$ part of the oxygen could thus be changed into ozone. A greater effect was, it is true, produced by the silent discharge between fine platina points; but this also had its limit. In order to carry on the process, it is necessary to introduce into the apparatus some substance, such as a solution of iodide of potassium,

which has the property of taking up, in the form of oxygen, the ozone as it is produced. After many trials, an apparatus was contrived in the form of a double U, having a solution of iodide of potassium in one end, and a column of fragments of fused chloride of calcium interposed between this solution and the part of the tube where the electrical discharge was passed. *The chloride of calcium allowed the ozone to pass, but arrested the vapour of water*; so that, while the discharge always took place in dry oxygen, the ozone was gradually absorbed. The experiment is not yet finished, but already one-fourth of the gas in a tube of the capacity of 10 cubic centimetres has disappeared. To produce this effect, the discharge from a machine in excellent order has been passed through the tube for twenty-four hours."

I make this extract from a paper that has appeared since my account of ozone was sent to the printer. It confirms with experimental evidence my double proposition, that oxygen alone *cannot* be converted into ozone, and that oxygen in the presence of an aqueous solution of iodide of potassium *can* be converted into ozone. But, while admitting the force of these experiments, I object to the explanations which I have printed in italic, because of the fallacies which they involve. It is an assumption, not a proved fact, that "the chloride of calcium allowed the ozone to pass, but arrested the vapour of water, so that the discharge always took place in dry oxygen." This point cannot be granted, it must be proved, because it involves the whole question. We have no evidence that chloride of calcium can, with absolute certainty, arrest every minute trace of the vapour of water. Dry oxygen cannot be converted into ozone. If *nothing* goes past the chloride of calcium from the solution to the dry oxygen, then the gas that is acted on is dry oxygen *plus nothing*, which evidently ought not to produce ozone. But, in this case, it does produce ozone, so that we have an effect without a cause. New properties are assumed to be given to dry oxygen by a liquid which is admitted to be present in the same tube with the oxygen, but which it is affirmed cannot get at it.

The conclusions which occur to me are these. 1. Oxygen gas produces no ozone, not even 1 per cent., unless hydrogen be present. 2. In the double U tube, the chloride of calcium permits the passage of a quantity of vapour sufficient to supply the oxygen with the requisite hydrogen. The ozone HO^2 is then produced, and becomes diffused through the mass of oxygen gas, which forms the atmosphere of the double U tube, and thus reaches the solution of KI, upon which it acts as already explained. 3. The solution of KI, not only takes up the ozone, but supplies the hydrogen necessary to produce it.

3. NITROGEN.

Synonyme : Azote.

Symbol, N; *Equivalent*, 14; *Specific gravity of Gas*, 14; *Atomic Measure when isolated*, 1 volume; *Atomic Measure when acting as an acid Radical in salts*, 1 volume; *Condensing power on other radicals in the state of Gas*, 0.

Occurrence. Principally in atmospheric air, which contains about four-fifths of its volume of nitrogen. It is also contained in all plants and animals, in guano, and in several minerals, such as native saltpetre, cubic nitre, coals, sal ammoniac, &c. See page 9.

Properties. A permanent gas, not reducible to the liquid state; destitute of colour, odour, and taste. Lighter than air. Sp. gr. = 0.97136, air being 1.00, or = 14, H being 1. 100 cubic inches at 60° F., and 30 inches Bar., weigh 30.119 grains. Incapable of supporting life, and thence sometimes termed *Azote*. Without action on coloured test-papers. Insoluble in water, or soluble only to the extent of 1 of nitrogen in 40 of water. Gives no precipitate when shaken in a bottle with lime-water. Not combustible. Incapable of supporting combustion, on which account the combustion of burning bodies is stopped when they are plunged into it. Nitrogen when isolated is more difficult to be recognised than other gases, because its properties are all of a negative character.

PREPARATION OF NITROGEN GAS.

5 volumes (measures) of atmospheric air contain 4 volumes of nitrogen gas, and 1 volume of oxygen gas. If the latter is absorbed by a combustible body, the former remains in an uncombined state.

1). Put a morsel of phosphorus, dried on blotting-paper, into a little porcelain or metal capsule, place the capsule upon a large cork, or a disc of wood, swimming on the water of the pneumatic trough, *d*; set fire to the phosphorus by a hot wire or a lucifer-match, and cover the capsule with a bell-glass gas-receiver, *a*, open at bottom and closed at top, and full of atmospheric air. The oxygen of the air combines with the phosphorus, and produces dense white vapours of phosphoric acid, which dissolve in the water, and leave the nitrogen gas in a state of tolerable purity. 10 cubic inches of air require about 1 grain of phosphorus.

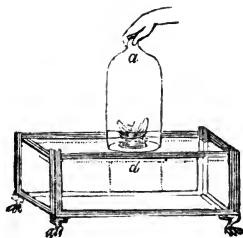

As the combustion proceeds, the water rises in the jar, and if there is sufficient phosphorus to combine with all the oxygen, and if time be allowed for the water to absorb the phosphoric acid, and for the gas and apparatus to become cool, it will be seen that about *one-fifth part* in bulk of the atmospheric air disappears.



253.

This experiment can be conveniently performed with a deflagrating jar, fig. 115, having attached to it the apparatus *a* to *e*, fig. 253. *a* is a caoutchouc cap which fits the neck of the jar, the stopper being removed; *b* and *c* are two bent glass gas-delivery tubes, *d* is a caoutchouc tube, and *e* a pinchcock, by which the caoutchouc tube can be closed or opened.

The nitrogen being prepared, and washed by moving the jar in the water of the trough, the gas can be transferred into small jars for examination by pressing the jar, fig. 253, down into the water of the pneumatic trough, and at the same time opening the pinchcock, *e*, to let the gas pass. The mouth of the tube, *c*, is directed below the mouth of the small jar, fig. 254, into which the gas is to be decanted.

If the gas passes over white from the presence of phosphoric acid, it can be purified by passing it two or three times from jar to jar through the water of the trough.



254.

2). Instead of phosphorus, a little alcohol may be burnt in a jar of atmospheric air by the above process, and its combustion serves equally to absorb the oxygen and leave the nitrogen. In this case, carbonic acid gas is also produced, but that gas is gradually absorbed by the water of the trough.

3). A stick of phosphorus placed in a small jar of air, over water, for 24 hours, absorbs all the oxygen and leaves the nitrogen, without being set on fire; but this process can only be used for preparing small quantities of nitrogen.

4). Introduce a lighted taper under a glass jar, standing over water, and filled with common air. The light will shortly be extinguished, a cloudiness will be perceived, which, however, will soon subside, and the water in the basin will rise in the jar.—*Rationale.* The atmospheric air is decomposed; the oxygen is absorbed by the burning taper, and the nitrogen remains. The cloudiness proceeds from the unconsumed smoke of the taper. The water rises in the jar, because the included volume of air is diminished by the absorption of its oxygen. The nitrogen gas produced by this process is less pure than that afforded by the first process.

5). Mix nitrate of ammonia with granulated zinc, distil the mixture in a retort, and pass the disengaged gas through water into a receiver. The gas is a mixture of ammonia and nitrogen. The former is absorbed by the water of the pneumatic trough, and the nitrogen gas remains alone.

6). A mixture of 14 parts of iron filings and 10 parts of dry saltpetre in powder, heated in a narrow tube of hard glass, gives off gas, which, when passed through water, leaves nitrogen.

7). *Preparation of Pure Nitrogen Gas.*—Copper, when heated to redness, completely absorbs oxygen from air. The apparatus represented by fig. 255 may be used for performing this experiment. A C_2 is a

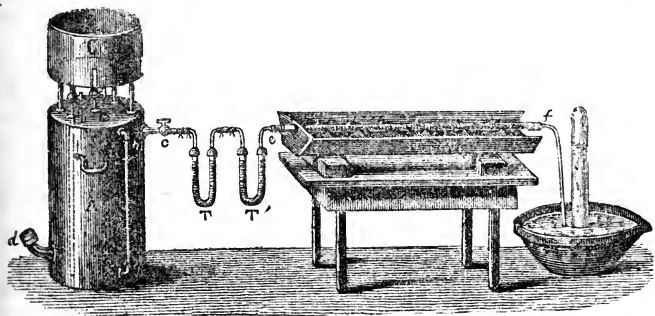

255.

Pepys's gas-holder, the details of which have been already sufficiently explained. See page 173. The infusible glass tube, *e f*, is filled with fine copper turnings, or fine, flattened copper wire. One extremity of this tube, *e*, is put into connection with *c*, the stop-cock of the gas-holder, and the other end of the tube *f*, is put into connection with a gas-receiver, suitable to collect the purified nitrogen gas. As atmospheric air always contains a small quantity of carbonic acid, and is, moreover, saturated with water in the gas-holder, these must be separated if we wish to obtain the nitrogen in a state of perfect purity. To that end, the gas is made to pass through the tubes marked *T* and *T'*. In the first of these tubes, *T*, the gas meets with pumice-stone, saturated with a solution of caustic potash, which absorbs the carbonic acid. In the second tube, it traverses pumice-stone, saturated with concentrated sulphuric acid, which absorbs the aqueous vapour with which the gas is charged. The infusible glass tube, *e f*, containing copper filaments, is placed in a long, narrow, sheet-iron combustion-furnace, in which it can be heated to redness. If the glass tube is not formed of infusible Bohemian glass, it must be wrapped round with copper foil, tied on with iron wire, to prevent the melting of the glass.

The atmospheric air contained in the gas-holder, A, is expelled by the pressure of water applied in the trough C; it is purified by passing through the tubes, T, and T¹; it is deprived of oxygen by the red-hot copper turnings contained in the tube *e f*; and the pure nitrogen gas is collected over mercury in the receiver attached to the end, *f*.

8). *Pure Nitrogen Gas can be separated from Ammonia.*—When chlorine gas is passed into liquid ammonia, pure nitrogen gas is separated; but the process is liable to prove dangerous; because an explosive compound of extreme violence is produced if the process is not properly conducted. This is a case, therefore, in which the way to run into danger, and the way to avoid it, require to be explained.

By means of the gas-bottle, fig. 256, chlorine gas is prepared according to the method which is described under the head "chlorine," hereafter. The chlorine gas is passed by the gas-delivery tube into the bottle represented by fig. 257, or into such bottles as are represented by figs. 138 and 139, in page 179. This bottle should be half filled with liquid ammonia (that is to say, solution of ammonia in water). The chlorine immediately loses its green colour, and the ammoniacal liquid immediately disengages a multitude of small bubbles of nitrogen gas, which may be collected as soon as the atmospheric air has

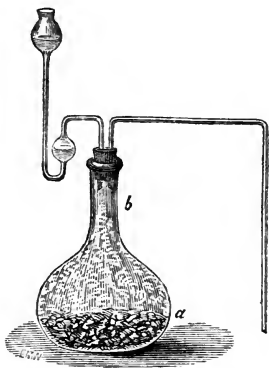

256.

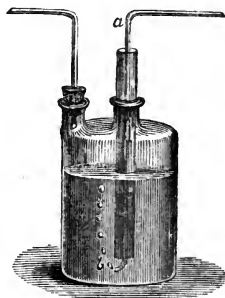

257.

been driven from the bottle. The reaction which takes place is as follows:—

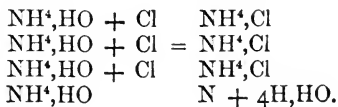

The solution of ammonia in water may either be considered as consisting of ammonia dissolved in water,

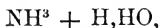

or as a solution of the hydrated oxide of ammonium, produced by a combination effected between the elements of an atom of water and of an atom of ammonia, the theory of which will be explained in a subsequent paragraph.



Four atoms of NH^4,HO , with three atoms of chlorine, produce three atoms of chloride of ammonium, NH^4,Cl ; four atoms of water, HHO ; and one atom of free nitrogen. The acting proportions are regulated by the principle stated at page 154, viz.: that whenever water is a product of any reaction, the decomposition must go on until, for every atom of oxygen set free, there is a simultaneous liberation of two atoms of hydrogen.

This experiment presents no danger as long as the solution of ammonia contains an excess of free ammonia; but if chlorine is passed into the liquor after all the ammonia is converted into chloride of ammonium, the chlorine then produces the chloride of nitrogen, which presents itself under the form of yellow oily drops. The production of this compound must be avoided with the utmost care, for it is one of the most violent detonating compounds now known to exist, and its presence indicates great danger to the operator.

EXPERIMENTS ILLUSTRATING THE PROPERTIES OF NITROGEN GAS.

Nitrogen gas, prepared by any of these processes, will be found to possess the properties cited in page 259. After decanting it, as described above, into several small jars, such as figs. 258 and 259, make the following trials of it. Plunge a lighted taper into it. Shake it in a bottle with lime-water. Try it with moistened test-papers, both litmus and turmeric. Endeavour to set fire to it.

If the gas has been completely deprived of oxygen, and sufficiently washed, all the trials will have a negative result. The taper will not burn; the lime-water will not become white; the blue litmus will not turn red; the yellow turmeric will not

turn brown the gas will not burn. It acts chemically upon nothing: it has no colour, no taste, no odour: it is not soluble in water. It does nothing: it suffers nothing. Its great character is, to have no distin-



258.

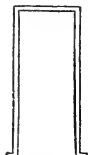

259.

guishing character. It is this negation of acting properties which peculiarly characterises this remarkable element.

Yet is nitrogen by no means a cipher in creation. If at given times it is the most dormant of elements, at other times it is the most active. Indeed, so many-sided are its operations when we consider it in relation to organised bodies, that we may fairly call it the chemical Proteus. The experimenter is unable to combine nitrogen directly with anything; but nature makes it form part of the most complicated and most antagonistic compounds. We live in an atmosphere formed chiefly of nitrogen; we inhale immense quantities of it hourly; yet our bodies retain none of the inhaled nitrogen, though every part of them is imbued with that element derived from other sources. In the air, nitrogen, continually in contact with oxygen and hydrogen, remains without action, and retains the utmost degree of bland indifference; yet these three elements combine indirectly to produce the two fiery and corrosive, but antagonistic compounds—liquid ammonia and aqua-fortis. With oxygen, it produces the laughing, intoxicating gas, which can be breathed with safety and delight; with the same element it forms the deadly nitrous gas. Though so indifferent to direct combination, once engaged in vegetable and animal compounds, nitrogen seems to be the very principle of vitality. It is there present where the vital processes are carried on with most activity. It is probably that agent which directs in the cells of plants the chemical and galvanic forces by which the raw materials of vegetable life are converted into the acting juices of the living plant. It is present in the most essential and delicate organs of the animal body. We cannot exist without it. It is contained in our bread and our beef. It is the principle of fermentation, and, therefore, concerns our beer and our wine. Food which is free from it has no power of nourishment. It is in the essence of tea, of coffee, and of chocolate. In sickness and fever we derive help and consolation from it in the form of morphia and quinine, and, sad to say, it is prompt to do irreparable mischief in the form of prussic acid and strychnia. Thus, our daily food, our holiday beverages, our solace in illness, and that which is the occasional cause of violent death, alike depend upon the presence of nitrogen. Even the military engineer finds in this mild element the spirit of remorseless destruction, for nitrogen is the basis of gunpowder, of gun-cotton, of the chloride and the iodide of azote, and of most of the explosive compounds which have in different ages ministered to the destroying power of the warrior.

ATMOSPHERIC AIR.

ATMOSPHERIC AIR is the term applied to that immense mass of permanently elastic fluid which surrounds the globe we inhabit. It is colourless, tasteless, inodorous, soluble in water to only a very limited

extent, compressible, and elastic. For a long time this substance was supposed to be simple, but it has now been proved, by experiment, to be a compound of oxygen and nitrogen. Five parts of common air contain about one part, by measure, of the former body, and four of the latter, or one hundred parts contain about twenty-one parts of oxygen and seventy-nine parts of nitrogen. The exact proportions have been disputed. According to the most trustworthy experiments they are as follows:—

By Measure.		By Weight.
20·81 = O		23·01 = O
79·19 = N		76·99 = N.

The proportions of these two gases, in atmospheric air, are uniform and constant. They have been found to be the same in all parts of the world, and in all seasons of the year; at the level of the sea, and when brought down by an aeronaut from an elevation of four miles above the surface of the earth. But this refers to air in its free or normal condition. "I hope," says Sir Humphry Davy, "it will not be conceived that I mean to apply this conclusion, as to the uniformity of the constitution of air, to close rooms, or to confined places, where there is no free circulation. I must not be mentioned as an authority for the salubrity of a crowded midnight ball-room or the press of a 'rout.' Where many candles and lamps are burnt—where a great number of persons respire the same air—it is scarcely possible, unless all the doors and windows are thrown open, to gain a sufficient supply of the pure atmospheric fluid to make up for the consumption. I have two or three times examined the air of very crowded and oppressive rooms, and in one instance I found as little as seventeen per cent. of oxygen, and three per cent. of carbonic acid. I collected air in different parts of Drury-lane Theatre, on a crowded night, by emptying small bottles filled with water. In the pit, at nine o'clock, there were nineteen of oxygen and one and a half of carbonic acid. In the second row of boxes, as soon after as the process could be conducted, there was a little more than these proportions, but no great difference. But in the highest tier, the impurity was greater; there were only eighteen of oxygen and as much as two and a quarter per cent. of carbonic acid.

"The deficiency of oxygen, in situations in common life, is seldom, however, a cause of unhealthiness, and more serious evils are produced by the vapours and effluvia which are suspended in the atmosphere in the solid or fluid state—vapours from putrefying animal matter, from decaying vegetables, and the products of combustion and various processes of decomposition. The great reason of the superior salubrity of a country atmosphere is not in the difference of the quantity of oxygen, but in the circumstance of the purity of the air from noxious impregnations. The air in the streets of London is continually convey-

ing to our lungs parts of whatever in so great a city is capable of very minute division either by chemical or mechanical means. The fogs which we experience are principally water thrown down by cooling from the upper regions of the air; but they often carry with them in the night, the smoke, the soot, and the various effluvia which have been raised during the day; and we sometimes breathe a vapour which before had passed through our chimneys."—*On the Chemistry of Nature*.

An elaborate and interesting series of researches "*On the Air of Towns*," has recently been published by Dr. R. Angus Smith, of Manchester (*Journal of the Chemical Society*, 1858, vol. xi., p. 196). The constitution of the atmosphere of Manchester, and the differences between town and country air in general, are very ably investigated in that paper, but the details are too copious for extract.

The two gases which compose air are commonly held to be mixed mechanically, yet the mixture answers very nearly to the chemical formula N^2O . The density of air is the 825th part of that of water. A cubic inch (barometer 30 inches, thermometer 60°) weighs 0.31 grain. The specific gravity of air is a subject that has been already discussed. See page 140. Air which has been breathed is found to have lost its oxygen, and is then no longer fit to support life. This element is retained in the lungs, where it is absorbed by the blood, from which it expels *carbonic acid gas*, and which it renders capable of supporting life. The red colour of the blood is owing to the oxygen it acquires in passing through the lungs.

Formation of Atmospheric Air.—If one measure of oxygen gas is mixed with four measures of nitrogen gas, the resulting mixture is one which agrees in all its properties with the air of the atmosphere.

Analysis of Atmospheric Air.—Air is confined in a graduated glass tube, over diluted sulphuric acid. A piece of copper foil is passed up into the tube through the diluted acid, and the apparatus is then left untouched for some hours. The moistened plate of copper during that time combines with all the oxygen of the air, and leaves nothing but nitrogen gas in the tube. Some of the processes for preparing nitrogen gas show other methods of analysing atmospheric air. The oxygen gas can also be separated from atmospheric air by explosion with hydrogen gas, as described at page 215.

Atmospheric air commonly contains carbonic acid gas in about the following proportion:—

Oxygen	500	}	= 2401 parts.
Nitrogen	1900		
Carbonic Acid	1		

The presence of carbonic acid in atmospheric air is capable of easy demonstration, as will be shown by an experiment described further on.

EXPERIMENTAL DETERMINATION OF THE COMPOSITION OF
ATMOSPHERIC AIR.

The analysis of atmospheric air requires two processes, the first of which serves to determine the proportion of carbonic acid and of vapour of water, and the second to ascertain the quantities of oxygen and nitrogen which compose pure air.

Quantitative Estimation of the Carbonic Acid and Water contained in Atmospheric Air.

Fig. 260 represents the apparatus which is employed to ascertain the quantities of carbonic acid and water contained in the atmosphere.

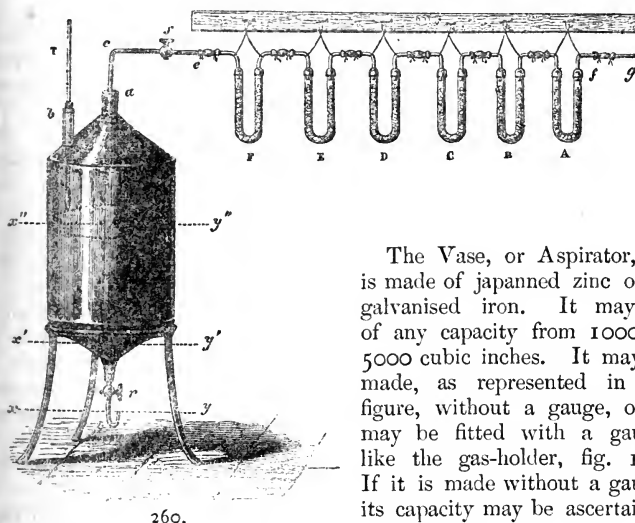

The Vase, or Aspirator, V, is made of japanned zinc or of galvanised iron. It may be of any capacity from 1000 to 5000 cubic inches. It may be made, as represented in the figure, without a gauge, or it may be fitted with a gauge, like the gas-holder, fig. 127. If it is made without a gauge, its capacity may be ascertained

by filling it with water, and running off the water into a measure, such as is represented by fig. 261, which, when filled up to a mark on the neck, contains a specific measure of liquid, such as 100 cubic inches. By successive fillings of this measure, and by the accurate measurement of the last smaller quantity which runs out, the exact capacity of the vase is ascertained. If there is a gauge-pipe attached to the vase, the points indicating the successive abstraction of 100 cubic inches are marked on the gauge-pipe or on the vase, by its side.

Letters *a*, *d*, in fig. 260, represent a pipe which passes to the bottom of the vase to regulate the flow of the water. T is a

thermometer which passes through the neck, *b*, to about the middle of the vase. The pipe attached to the stopcock, *r*, turns upwards to prevent the entrance of air into the vase. The air which is to be examined is brought by the tube *g*, which can be prolonged to any required distance.

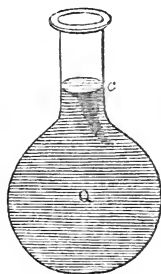

261.

The bent tubes A, B, C, D, E, F, contain substances which are intended to act upon the air. In A, B, E, F, are placed lumps of pumice-stone saturated with concentrated sulphuric acid, which serves to abstract aqueous vapour from the air which is passed through them. The tubes, C, D, are filled with pumice-stone saturated with a concentrated solution of caustic potash, which is adapted to absorb carbonic acid. The corks, by which these bent tubes are fixed to the connectors, are covered with sealing-

wax to prevent their absorption of external moisture and the entrance of air.

The two tubes, A, B, are weighed together, as are also the three tubes, C, D, E. The tube F is not weighed; it always remains attached to the apparatus, and its sole use is to prevent the passage of aqueous vapour from the vase, V, to the bent tubes A to E.

The vase being filled with water, and the apparatus being arranged as shown in fig. 260, and the tubes having been weighed, the stopcock *r* is opened, and the water is allowed slowly to run from the vase, either until it is emptied, or until a certain quantity of air, as shown by the gauge, or as registered by the quantity of water drawn off, has entered into the vase. That air, entering by the tube *a d*, and passing through the water, will necessarily be saturated with aqueous vapour. The temperature at the time is ascertained by the thermometer, T, and the height of the mercury in the barometer is also observed. From these data the corresponding measure of dry air at a standard temperature and pressure can be readily calculated.

The air, in passing through the bent tubes A, B, C, D, E, F, to penetrate into the vase, V, deposits its moisture with the sulphuric acid in the tubes A B, and its carbonic acid, with the caustic potash in the tube C D. But as the gas passes in a dry state from A B to C D, as it deposits its carbonic acid, it again takes up moisture. It is for this reason that the tube E is added, in which the moisture is again arrested. At the end of the experiment, after noting the quantity of aspired air, the two tubes, A B, are again weighed, and their augmentation of weight give the quantity of water which has been absorbed from the air. The three tubes, C, D, E, are also again weighed, and their augmentation of weight gives the quantity of the carbonic acid simultaneously abstracted from the air. In this manner we determine with exactness the

total quantity of dry air which passes through the apparatus, and the weight of the carbonic acid and the water which that quantity of air deposits.

Quantitative Estimation of the Oxygen and Nitrogen contained in Atmospheric Air.

Process 1. By means of Phosphorus.—A quantity of air is placed in a graduated glass tube over mercury, and is accurately measured. If the tube is washed with water, and partially dried with filtering paper, enough moisture will still adhere to the glass to saturate the small quantity of air. The phosphorus is melted under water, and cast in an iron bullet-mould into a small ball, into which, while soft, the bent end of a wire of platinum is plunged. The phosphorus is solidified by plunging the mould into cold water. The ball of phosphorus is thus provided with a long wire handle, by means of which it can be passed up through the mercury into the air confined in a jar, as shown by the figure. At the expiry of twenty or thirty hours the phosphorus will have absorbed all the oxygen. The ball is then to be withdrawn, and the residue is again to be carefully measured. This residue shows the quantity of nitrogen. Of course, proper corrections must be made, as in all experiments on gases, for the temperature and the barometric pressure at which these operations take place.

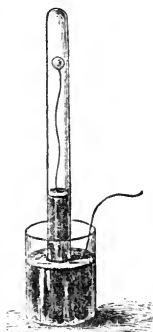

262.

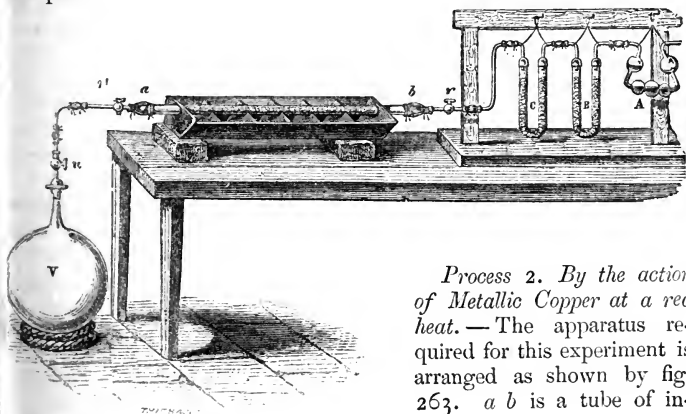

Process 2. By the action of Metallic Copper at a red heat.—The apparatus required for this experiment is arranged as shown by fig. 263. *a b* is a tube of in-

263.

fusible Bohemian glass, filled with fine copper-turnings and disposed on a combustion-furnace. It is provided at each end with a stopcock, r and r' . The end a of the glass tube is put into connection with a large glass receiver, V , of about 1000 cubic inches capacity, and the end b with a series of tubes, A , B , C , which contain materials for abstracting moisture and carbonic acid from the air that

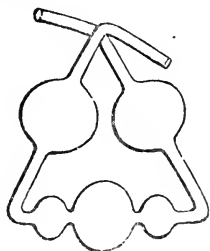

264.

is to be analysed. A is an apparatus which contains a solution of caustic potash, intended to absorb carbonic acid. This apparatus is shown on a larger scale by fig. 264. B is filled with fragments of pumice-stone saturated with a strong solution of caustic potash, with the intention to arrest any portion of carbonic acid that may escape the action of the solution contained in A . C contains pumice-stone saturated with concentrated sulphuric acid, for the purpose of abstracting moisture from the air.

When an analysis is to be made, the tube $a b$, containing the metallic copper, is attached to an air-pump, and is exhausted of air as completely as the power of the air-pump permits. The stopcocks are then closed and the exhausted tube is weighed.

The globe V is also exhausted of air, and is then weighed. That is far easier said than done. It requires a first-rate air-pump to effect the perfect exhaustion of so large a globe, and in weighing, the globe requires to be counterpoised by a second globe of the same size and weight, and the weighing to be effected by means of a powerful and accurate balance, with which objects of considerable bulk and weight can be weighed with extreme accuracy. These conditions demand the utmost degree of scientific skill and a large expenditure of money, and therefore I regard the description of this experiment rather as a history of one that has been once made, than as one suitable for every-day repetition.

The apparatus having been thus weighed and properly put together the fire is lighted and the tube $a b$ is heated. The stopcock r is then partially opened to permit the air to pass through A , B , C into the tube $a b$, to act upon the heated copper. After a while the stopcock u is opened, and then the stopcock r' , but only a little. The air must pass through the tubes very slowly. The course of the air is watched in the bulbs of A , through the solution in which the air must pass slowly in single bubbles. When they begin to pass very slowly, the stopcock is gradually opened wider, and, finally, both u and r' are opened to the greatest extent. When the action ceases, the stopcocks, r' , r , u are all closed, the charcoal is removed, and the apparatus is dismantled.

The globe V is again weighed, and the increase of weight shows the amount of nitrogen gas which has entered into it. The tube $a b$ is again weighed, and the increase of weight shows the quantity of oxygen

which has been taken up by the copper. But as, in this condition, the tube *a b* contains nitrogen gas, it is again exhausted by the air-pump and again weighed, which gives the means of correcting the weight.

From these results the percentage by weight of oxygen and nitrogen contained in atmospheric air can be reckoned with exactness, and the specific gravities of the two gases being known, it is equally possible to deduce the percentages by volume.

Process 3. By means of the Eudiometer.—The analysis of atmospheric air can also be made by means of the eudiometer, the use of which instrument I have already explained in treating of the Composition of Water. See pages 215 to 217. A certain quantity of atmospheric air is passed up into the eudiometer, and then a quantity of perfectly pure hydrogen gas (see page 227); the mixture is measured, fired by an electric spark, and again measured. The loss of measure consists of oxygen and hydrogen gas, in the proportions of one volume of the former to two volumes of the latter. Hence, one-third of the volume which disappears is the measure of the oxygen which was contained in the quantity of atmospheric air that was passed into the eudiometer for analysis.

Example.—Suppose 180 volumes of air to be taken, and as much hydrogen to be added as makes the mixture equal to 300 volumes. After explosion the measure is found to be 188 volumes. There is, consequently, a loss of 112 volumes, of which one-third = $37\frac{1}{3}$ is oxygen. Then we have the proportion

$$180 : 37\cdot33 = 100 : 20\cdot7,$$

which gives us nearly the proportions already cited as the true ones.

Professor Miller gives, as the average composition of the atmosphere in the climate of England, in 100 parts by volume—

Oxygen	20·61	
Nitrogen	77·95	
Carbonic acid	·04	
Aqueous vapour	1·40	
Nitric acid	}	traces
Ammonia	}	
and in	{ Sulphuretted hydrogen	traces
towns	{ Sulphurous acid	

Dr. Angus Smith's researches show the modifications which manufacturing operations produce in the atmosphere of such towns as Manchester.

EXPERIMENTS.—The experiments described above demand very superior apparatus and much skill in manipulation. I have described them

fully, that the reader may be impressed by the weight of the evidence which they afford. I now add a few experiments of a more manageable though less accurate character.

To show that the Atmosphere contains Water, even in the Driest Weather.—1. Expose to the open air for a few days a spoonful of dry carbonate of potash, or chloride of calcium, spread in a capsule: the salt will attract so much moisture from the air, that it will become liquid. 2. Put a given quantity of strong sulphuric acid into a vessel exposed to the air: at the expiration of twenty-four hours its weight will be found to have increased considerably. 3. Put very cold water, or a mixture of salt and snow, into a thin glass vessel, and take it into a warm room: dew will form on the outside of the vessel, arising from the condensation of the moisture contained in the air.

Method of determining the Hygrometric state of Atmospheric Air.—It is often of importance to know how much water is contained in a given bulk of air. This you can readily and accurately determine by the following process, employing the apparatus represented in the margin:—Water is run from the vessel, *a*, into the graduated vessel, *i*, where the quantity can be accurately measured. The water escaping from the vessel, *a*, is replaced by an equal measure of atmospheric air. This enters through the tube, *l, b*, which is loosely filled with asbestos, moistened with strong oil of vitriol. The latter absorbs the water from the air which passes over it. The tube, *l, b*, with its contents, is

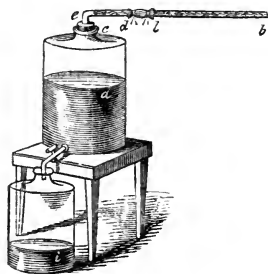

265.

weighed both before and after the experiment, and the increase in weight shows the quantity of water absorbed from a measure of air, equal to the quantity of water that is ran from *a* into *i*. The tube, *d, e*, is filled with lumps of chloride of calcium, in order to hinder the oil of vitriol in the tube, *l, b*, from absorbing vapour from the vessel, *a*.



266.

Deterioration of Air by Respiration.—The action of respiration in converting oxygen into carbonic acid can be readily shown by the apparatus represented by fig. 266. It consists of a two-necked Woulff's bottle, of about one pint capacity, fitted up with two bent tubes, and two-thirds filled with clear lime-water. Put the tube, *b*, into your mouth, and suck air through the water. It enters by the tube, *a*, and bubbles up strongly, but scarcely changes the appearance of the liquor. Ther

put the tube, *a*, into your mouth, and blow into the liquor air that has passed through your lungs. The liquor will soon be rendered turbid by deposited carbonate of lime.

Test for the presence of Oxygen Gas in Atmospheric Air.—Nitric oxide gas, passed up into a jar partly filled with common air over water, seizes upon the oxygen gas, forms with it an orange-red vapour, and condenses it. (See p. 190.)

Test for the presence of Carbonic Acid in Atmospheric Air.—Expose clear lime-water in a flat capsule to the air. It will soon become covered with a film of carbonate of lime, which, if broken, will fall to the bottom of the liquor, and before long be succeeded by a second film. This action will continue till the whole lime of the solution is changed into carbonate of lime.

Test for Acidity.—According to Dr. R. A. Smith, the air of towns where much coal is burnt contains so great a quantity of sulphuric acid, that moistened blue litmus paper soon has its colour changed to red. In preparing delicate test papers, I have often experienced the inconvenience of this action.

Test for Ozone.—The test for ozone is described at page 248. According to Dr. Smith, it is in vain to try to detect ozone in the air of large manufacturing towns, but easy to detect it in the atmosphere by the sea-side, or out in the country, on hills away from the smoke of the city.

THE AIR-PUMP.

It would be quite out of place to introduce into this compendium a systematic account of the science of pneumatics; but it may be useful and convenient to give a description of the air-pump, and of some pieces of apparatus connected with it, which are of continual use in chemical experiments, not only in investigations respecting the properties of common air, but of gaseous bodies in general.

Compressibility and Elasticity of Air.—Fig. 267 represents a glass cylinder about 2 inches in diameter and 12 inches in height, nearly filled with water, and bound over air-tight at the top by an elastic cap of vulcanised caoutchouc, such as those represented at page 179, only without the upper tube. Within it is a figure of glass, of a grotesque form, commonly called a bottle imp, or *Cartesian devil*. It is hollow, and has a small opening in one of the feet or in the tail. The weight of the figure is so adjusted, that, with the included air, it is very little lighter than water, and floats at the top of the jar. Nevertheless, when pressure is applied by the hand to the caoutchouc cover of the jar, the image sinks to the bottom of the water. As soon as the pressure is removed, the figure rises again to the top. The reason of this is, that the pressure of the hand condenses the

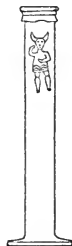

267.

air between the water and the cover of the jar. The condensed air then presses more heavily upon the water, and that in its turn upon the air contained within the image. This air is accordingly condensed into less space, and the image admits a little water, the addition of which makes the image and its contents heavier than the surrounding water, and therefore it sinks. When the hand is removed, the compression ceases, whereupon the elasticity of the confined air begins to act. The air within the image, resuming its original volume, expels the water through the hole by which it had entered, and the image, thus restored to its original weight, rises in the water.

If the pressure is continued until the image has too much water forced into it, it will no longer act properly. It should then be wiped dry, and be gradually warmed over a spirit-lamp, until the heat forces out of it a sufficient quantity of the superfluous water. Of course, this warming requires a little care, to prevent the cracking of the glass.

Sometimes glass images for this experiment are made in the shape of a balloon. The principle upon which they act is the same, and they require the same management.

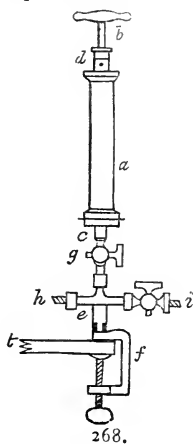

The Air-Syringe.—The fact that air expands when pressure is removed, so that the smallest quantity of it fills, in a uniform manner, the largest vessel, is that upon which is founded the exhaustion of vessels by the instrument called the *air-syringe*, or the *air-pump*. The annexed figure represents one of the forms of the air-syringe. *a* is a brass cylinder, bored with the greatest accuracy, and containing a piston, of which *b* is the rod and handle. This piston contains a valve that opens upwards but not downwards, so that when the piston is forced downwards, the pressure of the air below opens the valve, and the air passes through it; but when the piston is drawn upwards, the pressure of the air above closes the valve, and no air then passes through the valve. There is a small hole at *d*, by which the atmosphere communicates with the hollow part of the cylinder above the valve.

This syringe is connected to vessels, from which air is to be exhausted by means of adjuncts, of which I will give figures.

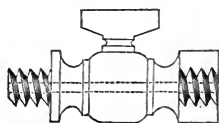
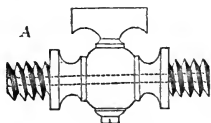

Stopcocks and Connectors.—Figs. 269 and 270 represent *stopcocks*. The moveable part in the middle, which can be turned by a handle, and which completes or cuts off the air-course, is termed the *plug*. The projecting screws of fig. 269 are termed *male* screws. The projecting screw of fig. 270 is also termed a *male* screw, and the hollow screw is termed a *female* screw. Figs. 271, 272, and 273 represent *connectors*.

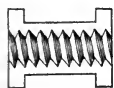

271.

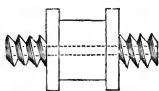

272.

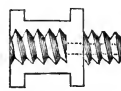

273.

271 is termed a *double female* connector, 272 a *double male* connector, 273 a *male and female* connector. There is one other kind of useful connector, which is represented by *a* in fig. 274, and by *h* in fig. 268. This is called a *coupling joint*. This connector is employed when neither the stopcock nor the object that is to be attached to it can be turned round, so as to make the screws enter the one into the other. It is a kind of connector a good deal used in fitting up gas-pipes. The neck *b* of fig. 274 is intended for insertion into a bag, or the neck of a bladder. Fig. 275 represents a cap intended to be cemented on the neck of a glass globe or a glass cylinder. Fig. 276 is adapted for a bag, bladder, flexible pipe, or the mouth of

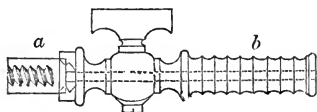

274.

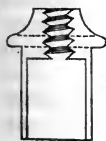

275.

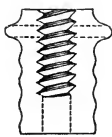

276.



277.



278.

any soft vessel that can be tied round it. Figs. 277 and 278 are blocks of brass, intended to be screwed by three screws to a table or block of wood, for the purpose of fixing syringes, &c., in particular postures, vertical, oblique, or horizontal, the inclination being determined by that of the surface of the wooden block to which it is screwed. All these adjuncts have female screws.

I have been particular in describing these little things, because they are of great importance in pneumatic chemistry. The student must learn what instruments are at his command, and by what technical names the instrument-makers distinguish them. All these adjuncts

should be made to fit each other precisely, that is to say, the screws should have what is technically called the same *thread*, and it is most convenient in a laboratory to have only one kind of screw or thread. The London philosophical instrument-makers have, by common consent, used, for nearly one hundred years, the same thread for air-pump apparatus. It is known as the *London stopcock thread*. The thread in common use among gas-fitters is entirely different. When stopcocks, connectors, &c., are screwed together, there should be a piece of oiled leather, or of sheet caoutchouc, called a *washer*, of the form of fig. 279, placed between them, to insure an air-tight joint. These washers must always be kept clean and soft, and the screws should be frequently cleaned and slightly oiled.

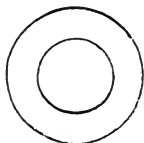

279.

When stopcocks are put aside out of use, they should be left *open*, as shown in figs. 269, 270; for, if they are exposed to corrosive vapours, which often happens in a chemical laboratory, they are less liable to damage in the plug, than when the plug is *closed*.

Farther particulars of the Air-syringe.—I now return to the description of the air-syringe, fig. 268. *c* is the neck of the syringe, and contains a female screw, *g* is a stopcock with two male screws. *e* is called a *cross-piece*, and is bored through from *h* towards *i*, and from the middle of that bore upwards towards *g*. The lower branch of the cross-piece is solid, and ends in a male screw, by which it is connected to the clamp, *f*, screwed to the edge of a table, *t*. The clamp, *f*, is not an essential part of the apparatus, for the cross-piece is often more conveniently fixed to the middle of a table, by means of one of the blocks, represented by figs. 277, 278. The cross-piece is terminated at the end, *i*, by a female screw, to which the figure represents a stopcock, fig. 269, as attached. The cross-piece is terminated at *h* by a coupling joint, or it may have a male or female screw.

The process of exhausting Air from Vessels.—The use of the apparatus is now evident. A vessel containing air, whatever may be its form, whether, for example, it be a globe or a tube, can be attached by one of the contrivances shown above, to one end of the cross-piece, and the other end of the cross-piece can be closed by a stopcock, or by a connector closed up at one end. The piston of the syringe being then lifted, the body of the syringe is filled by air from the vessel, which expands, so as to fill both the vessel and the syringe. The piston being then pressed downward, its valve opens, and the air in the cylinder that was below the piston passes above the piston. The piston being again lifted, that portion of the air is forced through the hole, *d*, in the upper part of the syringe into the atmosphere, while another portion of air passes from the vessel into the body of the syringe. The process is thus continued, until the air in the vessel is

reduced to so small a quantity that its elasticity is insufficient to raise the valve in the piston, when the exhausting power of the apparatus is at an end.

Figs. 280 and 281 represent other forms of double air-syringes. These are made with a solid piston and with two necks, one of which contains a valve which opens inwards, and which qualifies the syringe to act exhaustingly, while the other neck contains a valve which opens outwards, and constitutes it a condensing syringe.

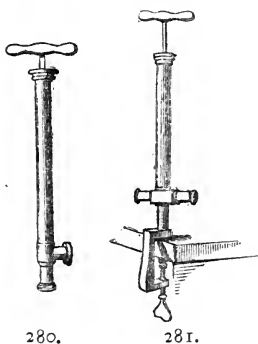

Determination of the Specific Gravities of Gases.—The foregoing description of the parts of an apparatus adapted to exhaust air from vessels, will enable you

to understand exactly the process by which the specific gravities of gases are determined. The apparatus employed for this purpose is represented by fig. 282. It consists of the following parts:—

1). A cylindrical jar, *a*, in which the gas can be collected. It may be graduated into cubic inches and decimal parts, into cubic centimetres, or according to the scale which has been explained at page 141.

2). A very light glass globe, *b*, fitted with a small and light brass cap *d*, and a small stopcock *e*. In the figure, the caps *d* and *c*, and the stopcocks *e* and *g*, are made of the same size. The figure, however, represents an apparatus suitable for other experiments in chemistry. But for the determination of the specific gravity of gases, not only must the globe *b* be made as light as possible, but the brass fittings *d* and *e* must also be made small, and very light.

3). The brass fittings *c* to *g* complete this apparatus; *c* is a cap cemented to the jar *a*. It has a female screw; *d*, a cap cemented to the globe *b*, has also a female screw; *f* is a connector with two female screws; and the two stopcocks *e* and *g* have each two male screws. These pieces are shown by the figures between 269 and 275, at about half the full size; except that the small cap *d* should not be longer than figure 275, and the stopcock *e* not larger than figure 269.

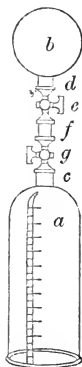

282.

The operation of taking the specific gravity of a gas is performed as follows:—

The globe, *b*, having been made perfectly clean and dry, is filled with perfectly dry atmospheric air, and with the cap, *d*, and stop-cock, *e*, is weighed. It is then screwed to an air-pump, or air-syringe, and ex-

hausted of the atmospheric air as completely as possible. The stopcock, *e*, is closed, and the globe is weighed again. The difference between the first weighing and the second shows the weight of the atmospheric air which has been withdrawn by the air-pump. The exhausted globe, *b*, is next connected to the receiver, *a*, by the intermediate brass-work shown in the figure. The two stopcocks, *e*, *g*, being then opened, gas passes from the receiver, *a*, into the globe, *b*, and fills it. The stopcocks are then closed, the globe, with its stopcock, *e*, is unscrewed from *f*, and once more weighed. The difference between the result of this weighing and of the second weighing shows the weight of the gas submitted to trial.

If the jar *a*, from which the globe is filled with gas, stands over water, the gas will be saturated with aqueous vapour, the quantity of which must be allowed for by calculation, or the gas must be passed, for weighing, not directly from the jar *a*, into the globe *b*, but through an intermediate apparatus for drying it, such as has been described at length in preceding sections.

If the globe *b*, employed for these experiments, be sufficiently large to contain, at 60° Fahr., and 30 inches Bar., 46·7 cubic inches of gas, that bulk will represent one grain of hydrogen gas, and that globe will contain the quantities of the elementary gases which are represented by the atomic weights of these gases. That is to say—

1 volume of hydrogen gas being	= 1	grain
1 volume of oxygen gas will be	= 16	grains
1 volume of nitrogen gas	„	= 14 „
1 volume of chlorine gas	„	= 35·5 „

And the quantity of a compound gas will be represented by its atomic weight divided by its atomic measure. Thus:—

1 volume of carbonic acid gas, CO_2 , will be = $44 \div 2 = 22$ grains.

1 volume of carbonic oxide gas, CO , will be = $28 \div 2 = 14$ grains.

The same volume of atmospheric air will be 14·47 grains.

The Air-Pump.—The air-pump differs essentially from the air-syringe only in having a table or horizontal plate of glass or brass ground perfectly smooth and flat, attached to its neck. In the apparatus represented in the figure, the neck with its female screw is situated in the centre of the plate below the cylinder, *a*. A tube passes thence through the body, or below the mahogany table that connects the whole together, till it reaches the lower end of the syringe. A small air-screw is added there, by which atmospheric air can be admitted into an exhausted vessel when required. The use of the ground table is merely to

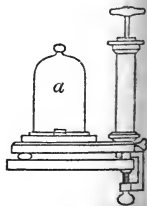

connect the air-syringe conveniently with vessels that have broad mouths like the jar *a* in the figure. The syringe is sometimes screwed to the table at an angle of about 45° , as represented by fig. 284. The apparatus is usually fastened to a table by one or more clamps, as shown by fig. 283.

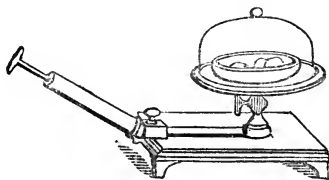

284.

TATE'S AIR-PUMP. — This air-pump is made on the principle first explained by Mr. Tate (see his paper "On a new double-acting air-pump with a single cylinder," in the "Philosophical Magazine," for April 1856). It is represented in perspective by fig. 285, and its barrel in section by figs. 286 and 287.

The barrel *a*, *b*, is a brass cylinder, 18 inches long, with a bore of $1\frac{1}{2}$ inch diameter. It contains two pistons, *c* and *d*, figs. 286 and 287, which are both attached to one piston rod, *e*, moved by the handle, *f*. The cylinder is firmly fixed in a horizontal position to a table by means of a massive brass clamp, *g*. The pump table, *h*, which is made seven inches or more in diameter, is fixed above the middle of the barrel by the block *i*, and the stopcock *k*. There is an aircock at *l*, to let air enter into the receiver *m*, when required. At the end of the barrel *n*,

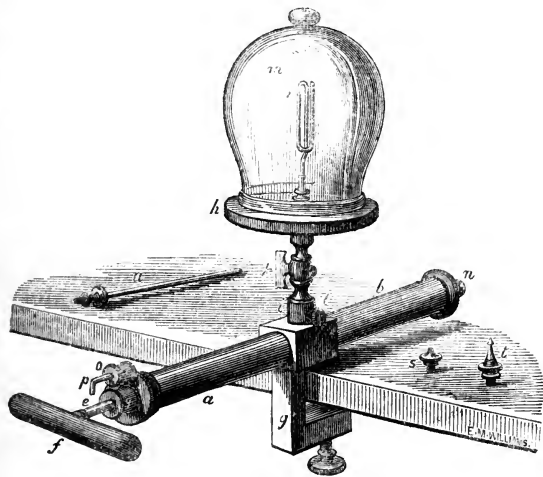

285.

there is a small orifice, with a valve opening outwards; this is covered by a brass cap, which has an external male screw. At the other end

of the barrel, *o*, there is also a small orifice with a valve opening outwards, and covered with a brass cap terminating in a bent pipe *p*.

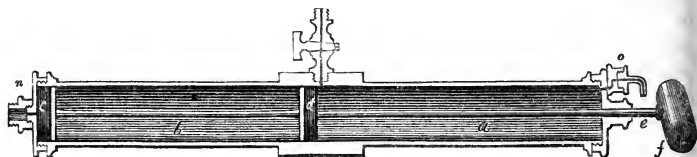

286.

To ascertain if the Pump is in good working order.—Clamp the pump firmly to a table, so that when the piston rod is pushed in, and pulled out, by means of the handle *f*, as far as it will go, there is no vibration of the table, *h*. If the pump works stiffly, pour a little oil (paraffine oil or neat's foot oil) into the hole in the middle of the table, *h*, after removing the syphon *r*, and opening the stopcock *k*. The oil will descend into the barrel, and lubricate the pistons, and will afterwards

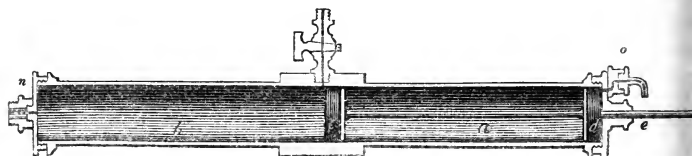

287.

be gradually forced out at both ends of the cylinder. The pipe *p* is so bent as to throw the ejected oil on the piston rod, which must always be clean and well greased. The oil which is projected from the end *r* can be collected in any kind of cover that is put loosely over it.

It sometimes happens, that when a pump is new, the pistons *set*, or become *fixed*. In that case, after clamping the pump firmly to the table, you may pull out the piston rod by main force. No harm will occur if you apply only as much force as is necessary for this purpose. The handle *f* must always be in a horizontal position, to be conveniently grasped by both hands, but as the piston easily turns round in the cylinder, the handle often comes into a vertical position. In that case you must put it into the horizontal position by turning it *from left to right*, and not from right to left, otherwise you may unscrew the piston rod from the piston.

Supposing the pump to be in working order, you must see that the plate *h* is clean, and that the receiver *m* is also clean, perfectly dry, and well greased on the flattened edge with tallow, or a mixture of wax and

tallow, according to the temperature. This grease can be conveniently applied by means of the tallow-holder described at page 100.

When the receiver is thus placed on the table, it is easy to ascertain by a few strokes of the piston, whether the junctions are all tight. If they are, the receiver soon becomes fixed to the table; if not, you must search for the leakage. All the parts of the pump should be tightly screwed up. Wherever there is a joint, there must be an intermediate oiled leather washer, and this washer must be always clean, and soft with oil, and from time to time it must be examined, and if defective, renewed. When the leakage is not at one of the joints, it is commonly found to be between the receiver *m* and the table *h*. If it is owing to defective grinding of the edge of the receiver, and that defect is but slight, a little more tallow may cure it; but if the grinding has been insufficient, or if there is a chip in the glass, the rim must be re-ground.

If a few strokes of the piston are found to fix the receiver upon the plate, the pump is in working order.

Action of this Pump.—The two pistons can be pushed into the positions shown by fig. 286. In this case, there is a communication between the receiver *m*, and that half of the barrel which is marked *a*. I assume that the stopcock *k* is open, and *l* shut. The pistons can now be pulled into the positions shown by fig. 287. There is then a communication between the receiver *m* and that part of the barrel which is marked *b*. By this second motion, all the air that was in the front half of the barrel *a*, is forced out of the barrel through the valve at the end, *o*—nearly all, but not quite all; for a small quantity of air remains in the little pipe between the piston *d* and the valve in *o*, and this expands into the half cylinder *a*, and into the receiver *m*, when the pistons are again put into the positions shown by fig. 286. In that third movement, the air contained in the half *b*, of the barrel, as shown in fig. 287, is forced out through the valve at the end *n*, except, as before, a small residue in the pipe between the piston *c*, and the valve in *n*. That this residue may be as little as possible, the pistons must at each movement be driven quite home. But this must be done firmly and steadily, not with too much violence or too much rapidity. The operator must remember that all the air that is expelled at each stroke has to pass through an opening which is, for the above reason, made as small as possible, and he must not give this little hole and the valve belonging to it too much work to do. If the barrel of the pump, and above all, the stuffing box, *q*, becomes hot to the hand during the pumping, the operator is pumping too fast, and he must work more deliberately. Another precaution which he must take is, to work the piston rod as evenly as he can in the direction of the cylinder, and not to make it waddle in the stuffing box, *q*. If it waddles, the hole in the stuffing box will speedily become enlarged, the pump will leak seriously, and the

stuffing box will require to be repacked;—work for the instrument maker.

The exhausting power of the pump is tried by means of the syphon gauge, which is marked *r* in fig. 285. That this may show the state of the exhaustion in the receiver *m*, a hole is bored in the brass foot by which the gauge is screwed into the hole in the table. With a receiver that is capable of holding 100 cubic inches of air, Tate's pump of the above size, and in perfect condition, will bring down the mercury to one-twentieth of an inch in about 60 strokes. It will also readily freeze water over sulphuric acid in a flat receiver of 300 cubic inches; but the requisite number of strokes for this experiment varies greatly with the temperature of the water, and of the apparatus, and the apartment, from 150 strokes at between 60° and 70° Fahr., to half that number at between 30° and 40° Fahr.

The other pieces of apparatus shown in fig. 285 are, a screw, *s*, adapted to the hole in the table, *h*, and intended to prevent the running of water and mercury into the barrel of the pump, when spilt in certain experiments on the table, *h*; the jet *t*, and the water-pipe *u*, are for the experiment called a *fountain in vacuo*, which I shall describe presently.

Use as a Condensing Pump.—If a globular vessel mounted with a brass cap, containing a female screw, is adapted to the screw at the end of the barrel *n*, the air which is there ejected from the pump will be necessarily forced into the vessel so placed to receive it.

Advantages possessed by Tate's Air-pump.—There is no valve placed between the receiver and the barrel of the pump, so that when the air becomes rarefied, it is not required to lift a valve, but has simply to diffuse itself as each half of the barrel is alternately opened to receive it. The pump is not difficult to work. Though the barrel is 18 inches long, the effective stroke is only 8 inches. At first, the friction of two pistons makes the pull rather stiff, but as the exhaustion proceeds, the pull becomes easier, because the action of the external atmosphere is cut off from the pistons by the valves placed at *o* and *n*, which is the reverse of what occurs with all pumps that have valves placed between the cylinder and the receiver.

Air-pumps with double Barrels.—Though Tate's pump is a great improvement upon all single-barrel air-pumps, and does the work of exhaustion thoroughly, yet as its power is only in proportion to the capacity of its barrel, it does not work with sufficient expedition for a lecturer who desires to perform a series of experiments before a large and perhaps an impatient, audience. When the size of the barrel is much enlarged, the labour is too heavy for the operator's hand. The piston rod must be worked by a rack and pinion moved by a lever, and the apparatus then becomes expensive.

To meet the necessity of a more rapid, though less effectual exhaus

tion, recourse is had to air-pumps with double barrels, two common forms of which are represented in figs. 288 and 289.

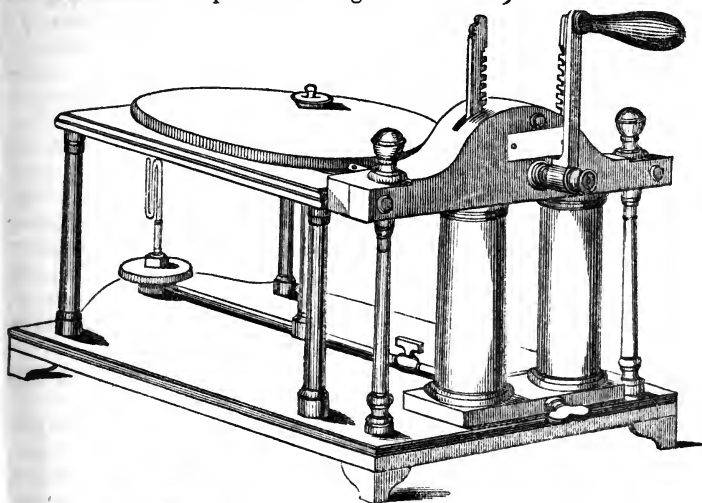

288.

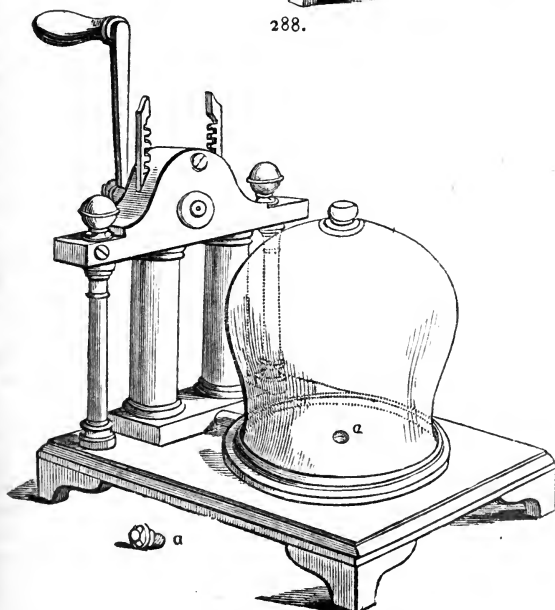

289.

Fig. 288 is a pump with a raised plate and a syphon-gauge. Fig. 289 is a pump of a cheaper construction without a syphon-gauge. It is also represented in the figure without a stopcock between the receiver and the barrels, which is a very unadvisable piece of economy, because it presupposes an absence of leakage at all joints of the pump which, though desirable, is not always obtainable, especially when the pump is old.

In pumps of this description there are valves in the pistons, and also at the base of each cylinder, and the exhausting action of the pump ceases when the rarefied air in the receiver is no longer able to lift the lower valve when the piston is drawn upwards in the barrel. The labour of pumping increases with the exhaustion, and with wide barrels is considerable, because you have a vacuum under the piston and the full pressure of the atmosphere upon it, whereas in Tate's pump the pressure of the atmosphere is cut off from the pistons by the valves, which open outwards only, at the two ends of the barrel.

When rapid action and complete exhaustion are both required, it is advisable to use the large size of Tate's pump.

Evaporation in a Vacuum.—It is often desirable in chemical operations to expel water from substances which cannot be heated without being made to undergo changes that are injurious. In such a case the chemist avails himself of the power of the air-pump.

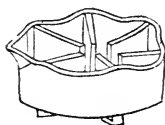

290.

A porcelain pan, similar to fig. 290, is half filled with concentrated sulphuric acid, a liquid which rapidly absorbs aqueous vapour, and this is placed upon the table of the air-pump. The substance that is to be evaporated or dried is placed in a watch-glass or a porcelain capsule upon this pan. The whole is covered with a flat glass receiver, such as is represented in fig. 284, and the air is exhausted from the receiver. Water then rises from the substance that is to be dried to form an atmosphere in the receiver, but the concentrated sulphuric acid rapidly absorbs it; fresh vapour is then formed and is absorbed by the acid, and thus the evaporation proceeds till the required result is produced.

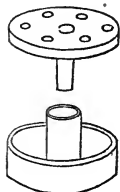

291.

It is sometimes expedient to dry substances contained in filters without removing them from their glass funnels; in which case the arrangement represented by fig. 291 is useful. The lower part of this apparatus is made of porcelain, and the upper part of wood. Acid is put into the porcelain pan, and the wooden table being placed over it, the funnels and capsules containing the mixtures that are to be dried are placed upon the table. The exhaustion and evaporation then proceed as described in the preceding paragraph.

The apparatus last described is sometimes employed with concentrated sulphuric acid to dry substances without the aid of the air-pump. The method of proceeding is shown by fig. 292. B is a round wooden table, in which is turned a circular groove, *m m*. A is a glass or metal receiver, which fits the groove *m m*. *a* and *b* represent the apparatus, which is shown separately by fig. 291. If the receiver A is made of tin-plate, the groove *m m* is filled with oil. If the receiver is of glass, the groove may be filled either with oil or mercury. With this apparatus the evaporation goes on more slowly, because the air in the receiver prevents the rapid vaporisation of the water.

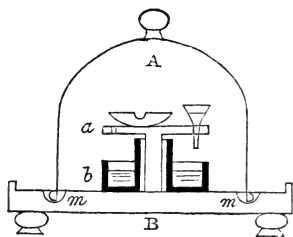

292.

Freezing of Water.—With the help of Tate's air-pump, the porcelain acid-pan, fig. 290, and the flat receiver, fig. 284, it is easy to freeze water. The pan must be half filled with concentrated sulphuric acid, not the fuming Nordhausen acid, but oil of vitriol that has not been diluted. The water should be put into a watch-glass, placed upon the acid pan.

This experiment succeeds best when the pump, the water, and the air of the room are as cold as possible. The pump and every part of the apparatus being in good condition, it takes twice as many strokes of the piston to freeze water when the air is at 60° F. as it takes when the air is at 40° F. In winter, when the apparatus and water are tolerably cold, Tate's pump will freeze the water with less than 100 strokes. In summer, at about 60° , it will require at least 150 strokes; and if you allow the water and pump to stand in the sun till they are warm, or if you take diluted acid, or too much water, or too large a receiver, you will entirely fail to freeze the water.

A small quantity of water is, of course, more easily frozen than a large quantity; but when Tate's pump (the small size) is in good condition, and the weather cold, three or four ounces of water can be frozen, if placed in a thin porous earthenware capsule.

As Tate's pump is usually sold with adjuncts for producing a fountain in vacuo, I shall add a description of that experiment.

Fountain in Vacuo.—The table *h* of Tate's air-pump can be unscrewed in company with the stopcock *k*, from the block *i*, fig. 285. The jet *t* can be screwed into the hole in the middle of the plate *h*. The pipe *u*, fig. 285, or *a*, fig. 293, can be screwed to the stopcock *k*. These letters refer equally to figs. 285 and 293.

Process.—The pump being in good working order, ascertain that the table *h* and stopcock *k* are easily removable. Screw up tight, put in the jet *t*, cover with the conical glass receiver B; or, in default of

that, with the cylinder of the guinea and feather glass closed at top with a well-greased glass plate. Have ready a wide-mouthed bottle or jar, A, filled with water nearly to the neck; also a thin disc of glass, wood, or metal, with a hole in the centre, C. Exhaust. Close the stopcock *k*, and then unscrew it, and all above it, from the pump. Put on the disc C, screw on the pipe *a*, and place the whole upon the glass bottle A. If the stopcock *k* is now opened, the weight of the atmosphere acting on the surface of the water in the vessel A forces the water, in the form of a jet or fountain, up into the exhausted receiver B.

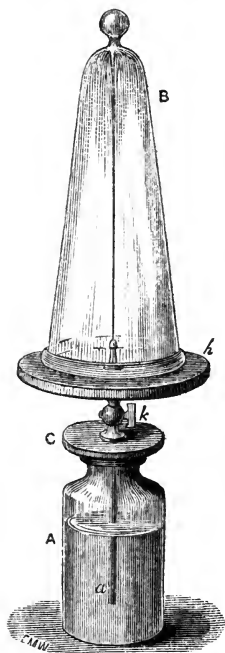

293.

As this experiment wets the plate and stopcock of the pump, and renders them unfit for other experiments until thoroughly dried, it is better to use for it a separate small table and stopcock, which is commonly called a transferer. When a teacher has no separate transferer it is better to defer experiments with water till the other experiments of the same day's lesson have been performed, because it takes some time to dry the transfer-plate and the stopcock sufficiently to enable other exhaustions to be made by the pump; for the presence of vapour diminishes its power.

COMPOUNDS OF NITROGEN AND OXYGEN.

There are five known compounds which contain nitrogen and oxygen. These are as follow :—

		Atomic Weight.	Atomic Measure.
Nitrous oxide	NNO	44.	2 volumes.
Nitric oxide	NO	30.	2 volumes.
Nitrous acid	NNO ³	76.	?
Peroxide of nitrogen	NO ²	46.	2 volumes.
Nitric acid	NNO ⁵	108.	?

In these formulæ, N = 14, and O = 16. When the atomic weights are held, as they commonly are, to be N = 16 and O = 8, of course the formulæ of these compounds are written differently. In considering the following details, the reader will be pleased to remember that the symbols N and O each signify *one volume of gas*, and that N weighs 14, and O weighs 16.—See page 148.

NITROUS OXIDE.

Synonymes. Protoxide of Nitrogen, Laughing Gas, Intoxicating Gas.

Systematic name, Nitra nitrate.

Formula, NNO; *Atomic Weight,* 44; *Specific gravity of Gas,* 22;

Atomic Measure, 2 volumes. *Neutral to test papers.*

Properties. A colourless gas, heavier than common air. It supports combustion, sometimes with brilliancy, but, though it may be respired, it is not capable of supporting life. It has a sweet taste, and a faint but agreeable odour. It dissolves in three-fourths of its bulk of common cold water. Water which has been boiled absorbs about one-half of its bulk of it. Warm water absorbs less of it. It is reducible by a pressure of 50 atmospheres at 45° to the liquid state. It does not form red vapours when mixed with air or oxygen gas. The most extraordinary property of this gas is its action on the human body, when respired. The sensations that are produced vary greatly in persons of different constitutions; but in general they are highly pleasurable, and resemble those attendant on the pleasant period of intoxication. It has been called *intoxicating gas*, *laughing gas*, and *gas of Paradise*. This characteristic of nitrous oxide gas was discovered by Sir Humphry Davy.

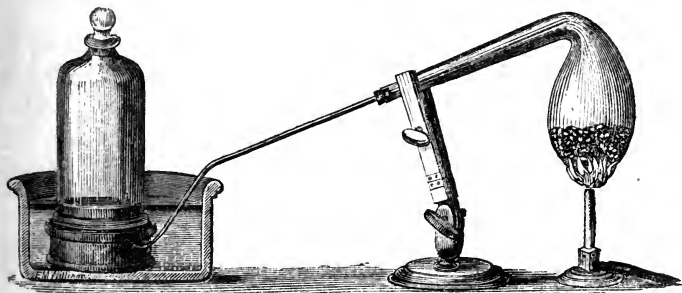

294.

To procure Nitrous Oxide, or Intoxicating Gas.—Put a quantity of pure nitrate of ammonia into a glass retort, as represented in fig. 294, and apply the heat of a lamp, which must be gentle and well regulated. The salt will in a short time liquify, and must then be kept gently simmering, avoiding violent ebullition, otherwise the gas will be impure. The temperature should be carefully watched. It ought to be between 400° and 500° F. If suffered to become much higher, white vapours appear in the retort, and the decomposition of the salt hurries on with explosive violence. The gas may be collected over water, and must be allowed to stand a few hours before it be used; during which time it

will deposit a white vapour, and become perfectly transparent. When great purity is required, and when the gas is to be breathed, it may be passed through a U-tube, page 198, containing a solution of protosulphate of iron. Four ounces of nitrate of ammonia produce a cubic foot of nitrous oxide gas.—Do not dip the neck of the retort into the trough till the gas passes out rapidly, which you ascertain by holding the mouth of the retort in a small capsule containing water.

Theory :— $\text{NH}_4\text{NO}_3 = \text{NNO} + \text{HHO} + \text{HHO}$.

One atom of nitrate of ammonia produces one atom of nitrous oxide and two atoms of water. If the salt is impure, other products are formed, for which reason the gas must be carefully washed, by agitation with water and by being left for some hours in contact with water, before it is breathed.

Experiments showing the properties of Nitrous Oxide Gas.—1. A candle burns in it with a brilliant greenish flame and a crackling noise.—2. Phosphorus, charcoal, sulphur, and iron wire burn in it. The experiment may be performed in the same manner as is directed for experiments with oxygen gas, page 181; but bodies that are to be burned in nitrous oxide gas must be introduced into it in a state of complete ignition.—3. When mixed with hydrogen gas, it burns with explosion.—4. A bit of potassium passed up into a jar of this gas standing over water inflames and burns brilliantly.

Intoxicating power of Nitrous Oxide Gas.—Though this gas is not fitted to support life, yet it may be respired for a short time, and the effects produced by it upon the human frame are among its most extraordinary properties. The manner of breathing it is as follows:—Put nitrous oxide gas that has been purified by washing with water, over

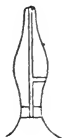

295.

which it should rest for some hours, into a large bullock's bladder, or a gas-bag, with a perforated wooden mouth-piece, such as is figured in the margin, fixed in its neck. Hold the bladder by means of the mouth-piece in the right hand. Close the nostrils with the left hand, and exhaust the lungs of common air by a long expiration. Then put the tube into your mouth and breathe the gas from and into the bladder as long as you can. The effect produced is a sort of delirium, which differs greatly according to the constitutions of the persons by whom the gas is respired. In general, however, the effects are *highly pleasurable*, and resemble those attendant on the agreeable period of intoxication. "Exquisite sensations of pleasure—an irresistible propensity to laughter—a rapid flow of vivid ideas—singular thrilling in the toes, fingers, and ears—a strong incitement to muscular motions"—are the ordinary feelings produced by it. The celebrated Mr. Wedgwood, "after breathing the gas for some time, threw the bag from him, and kept breathing on laboriously with an open mouth, holding his nose

with his fingers, without power to remove them, though aware of the ludicrousness of his situation; he had a violent inclination to jump over the chairs and tables, and seemed so light that he thought he was going to fly." What is exceedingly remarkable, is, that the intoxication thus produced, instead of being succeeded by the debility subsequent to intoxication by fermented liquors, does, on the contrary, generally render the person who takes it cheerful and high-spirited for the remainder of the day. In some cases, however, the effects are unpleasant, such as headache, a rush of blood to the head, and a tendency to stupor. The experiment should therefore be made cautiously. It is best when the bag of gas is managed by an assistant, because it often happens, that even when the effect is unpleasant, the experimenter has not the power to remove the bag from his mouth. For this reason a side opening is made in the mouth-piece, which the assistant closes with a cork or his thumb, and can readily open when necessary. The patient then breathes only atmospheric air.

NITRIC OXIDE.

Synonymes. Dioxide of nitrogen, Deutoxide of azote, Nitrous gas.
Systematic name, Nitrate.

Formula, NO; *Atomic Weight,* 30; *Specific gravity of Gas,* 15;
Atomic Measure, 2 volumes; *Neutral to test papers.*

Properties. A gas, whose specific gravity is slightly greater than that of air. It is colourless, but when suffered to mix with air, or with oxygen gas, it produces brilliant red suffocating fumes, being by its union with oxygen converted into peroxide of nitrogen, which immediately disappears if in the presence of water. Nitrous gas does not redden litmus. It is not combustible; it is fatal to animal life, and extinguishes flame. There are, however, a few bodies that can be burnt in it, such as phosphorus and charcoal. Water absorbs about 1-20th of its bulk of this gas. It is copiously absorbed by a solution of ferrous sulphate, FeSO².

Preparation of Nitrous Gas.

Process 1.—Put 100 grains of shreds of copper into a gas-bottle, page 192, and add 300 grains of nitric acid, diluted with an equal weight of water. Collect the gas which is disengaged over water, first allowing a quantity to escape to get rid of the common air of the gas-bottle. See page 180. When the evolution of gas ceases, the application of a gentle heat will cause the production of another portion of gas. A blue liquid will remain in the retort, which liquid is a solution of nitrate of copper. Preserve it for other experiments.

Theory :— $3\text{Cuc} + 4\text{HNO}^3 = 3\text{CucNO}^3 + 2\text{HHO} + \text{NO}$.

Three atoms of copper and four atoms of hydrated nitric acid produce three atoms of nitrate of copper, two atoms of water, and one atom of nitric oxide.

Process 2.—“The deutoxide of nitrogen may also be obtained perfectly pure by digesting hydrochloric acid with iron filings till it will dissolve no more, decanting the clear liquid, and adding to it its own bulk of hydrochloric acid: on placing the solution in a retort, and adding nitrate of potash, the deutoxide of nitrogen is immediately evolved in large quantity.”—*Professor Miller*.

Theory :—

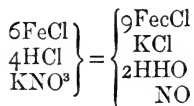

In this reaction 6 atoms of ferrous chloride produce 9 atoms of ferric chloride. The extent of the reaction depends upon the quantity of oxygen supplied by the decomposed nitrate; O^2 demand H^4 to produce water. The other decompositions depend upon this point.

Experiments with Nitric Oxide Gas.—1). Add a few drops of sulphide of carbon to a jar of this gas. If a light is now applied, the mixture burns with a bright blue flame.—2). Nitrous gas is readily absorbed by a saturated solution of protosulphate of iron or protochloride of iron. The resulting dark-brown solution readily absorbs oxygen gas.—3). If nitrous gas is collected in a bottle or gas-tube containing a weak solution of litmus, or which has a slip of blue litmus paper pasted along the inside, the blue colour of the litmus remains unchanged, but if common air or oxygen gas is let into the bottle, the litmus immediately turns red, because nitrous acid is formed.—4). Charcoal or phosphorus may be burnt in this gas. The experiment is to be performed as described at page 182.—5). If a lighted taper is plunged into this gas the light is extinguished.—6). Exhaust the globe of the apparatus represented by fig. 296. Partially fill it with nitrous gas, by screwing the globe to the cylinder, opening the stopcocks, and letting a certain quantity of that gas pass up from the cylinder to the globe. Then close the stopcocks, clean the cylinder, and put into it some oxygen gas, the cylinder standing over water. Open

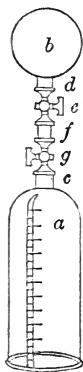

296.

the stopcocks, upon which red fumes will immediately appear, and if there be no excess of either gas, the water will rise and fill the globe, absorbing all the gas. A long slip of blue litmus paper may

be passed into the globe through its cap before it is exhausted of air, in order to render the production of acid obvious.—7). If a solution of an alkaline sulphite is brought into a bottle containing nitrous gas, and shaken with it, the gas is transformed into nitrous oxide gas, and no longer produces nitrous acid when mixed with air or oxygen gas.

NITROUS ACID.

Synonymes. Sometimes called hyponitrous acid. Systematic name, Nitra nitrite.

Formula, NNO^3 ; *Atomic Weight,* 76; *Specific gravity and atomic measure of the gas not yet ascertained.*

In all probability this compound is correctly represented by the formula $\text{NO} + \text{NOO}$. It is produced by mixing 4 volumes of nitric oxide with 1 volume of oxygen, both made dry and conveyed into an exhausted flask. Hence:—



The compound thus produced is in the form of a brown-red vapour. At the temperature of -4°F . it condenses to a blue and very volatile liquid, which boils at a degree of heat below that of the freezing point of water. If subjected to distillation it falls into nitric oxide and peroxide of nitrogen. Thus:—

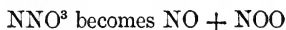

Nitrous acid dissolves in very cold water, forming a pale-blue solution, which is probably hydrated nitrous acid:—

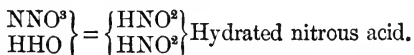

This formula agrees with the constitution of the salts called *Nitrites*, which are to be described further on.

If the temperature is raised above 32°F ., the acid is decomposed into nitric acid and water, which remain in solution, and nitric oxide, which flies off as gas. This action may be explained as follows:—

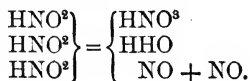

PEROXIDE OF NITROGEN.

Synonymes. Hyponitric acid; sometimes Nitrous acid. Systematic name, Nitrete.

Formula, NO^2 ; *Atomic Weight,* 46; *Specific gravity of Gas,* 23; *Atomic Measure,* 2 volumes. *Reddens litmus.*

Preparation.—1). Whenever nitrous gas comes into contact with oxygen gas, or atmospheric air, dense yellow fumes of peroxide of nitrogen = NO^2 are produced.

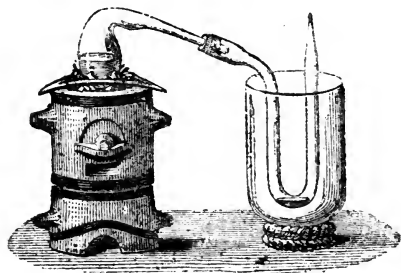

297.

2). When dry nitrate of lead is distilled, and the product received in a vessel, artificially cooled, nitrous acid is procured in a liquid form. The proper apparatus for this experiment is represented by fig. 297. As the heat required is considerable, the retort must be made of infusible glass, or be coated with clay. The beaker in which

the bent tube receiver is placed must be charged with ice and water. The nitrate of lead must be perfectly free from water. The decomposition occurs as follows:—

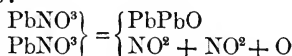

That is to say, the products are protoxide of lead, peroxide of nitrogen, and free oxygen.

Properties.—At -4° F. it can be obtained in colourless prismatic crystals. With a slight increase of heat it forms a colourless liquid, but if the heat is raised the liquor assumes various colours, darkening through yellow to deep orange-red. Once fused, the crystals do not readily form again, owing to the presence of a little nitric acid. At about 80° F. the liquor boils. Its vapour has an intense red colour. Its density is given above. It reddens litmus and stains animal matters yellow, but it is not an acid. It forms no salts, except by affording elements towards the construction of nitrites and nitrates.

Peroxide of nitrogen is very easily decomposed by water, a small quantity of which converts it into a green liquid. When acted upon by bases it produces a mixture of nitrates and nitrites in equal equivalents. Many different explanations have been given of these reactions, and some of them sufficiently complicated; but on the radical theory they seem simple and intelligible.

Thus, the reaction with water is this:—

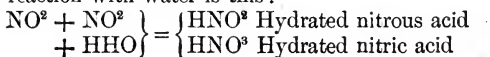

And the reaction with bases is as follows:—

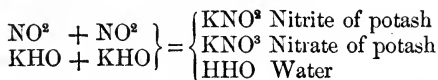

There are, however, some other reactions of peroxide of nitrogen with water which demand a brief notice. Sometimes a large quantity of nitric oxide gas is disengaged. This can be explained thus:—

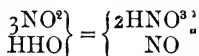

Sometimes the liquor remains in such a state that if platinum, copper, or silver is put into it, a violent effervescence and discharge of nitric oxide occurs. That effect would lead to the supposition that peroxide of hydrogen is present, which indeed is quite possible; for

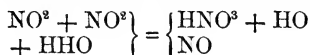

If peroxide of nitrogen is passed over barytes at 200° , the earth suddenly becomes red hot, and produces nitrate and nitrite of barytes. Thus:—

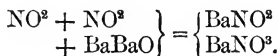

ANHYDROUS NITRIC ACID.

Formula, NNO^2 ; *Atomic Weight*, 108; *Systematic Name*, Nitra nitrite.

Anhydrous nitric acid has been prepared by M. St. Claire Deville. The method is, to decompose perfectly dry nitrate of silver by perfectly dry chlorine gas. Heat is applied to vaporise the liberated anhydrous nitric acid, and to carry it into a separate vessel, to be condensed by a freezing mixture. The experiment demands great care and skill in manipulation. See *Ann. de Chimie*, III. xxviii. 241; also *Miller's Elements of Chemistry*, I. 499; and *Gmelin's Chemistry*, II. 389.

Notwithstanding the utmost care, part of the acid is decomposed; otherwise the decomposition is effected as follows:

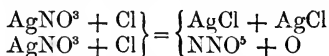

That is to say, two atoms of nitrate of silver and two atoms of chlorine yield two atoms of chloride of silver, one atom of anhydrous nitric acid, and one atom of free oxygen.

Properties.—Brilliant transparent colourless crystals, whose forms are modifications of a right rhombic prism. They fuse at 85° F., and

the liquid boils at 113° F. The vapour decomposes so near the boiling point that the density of the gas cannot be determined.

Anhydrous nitric acid dissolves completely in water, producing a great rise of temperature, but no production of colour, and no disengagement of gas.

The product is hydrated nitric acid :

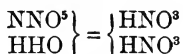

The solution saturated with barytes gives nitrate of barytes :

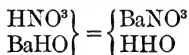

The nature of the compound denoted by the formula NNO^5 will be investigated under the head of "doctrine of the anhydrides."—See page 295.

I will now place together the names which are supplied for these five oxides of nitrogen by the systematic nomenclature that has been explained at page 132.

		Proposed Names.
Protoxide of nitrogen	}	= NNO = Nitra nitrate
Nitrous oxide		
Laughing gas		
Deutoxide of nitrogen	}	= NO = Nitrate
Binoxide of nitrogen		
Nitric oxide		
Nitrous gas	}	= NNO^3 = Nitra nitrite
Nitrous acid		
Hyponitrous acid		
Peroxide of nitrogen	}	= NO^2 = Nitrete
Hyponitric acid		
Nitrous acid		
Anhydrous nitric acid	}	= NNO^5 = Nitra nitrate

NITRIC ACID AND THE NITRATES.

The constitution of nitric acid and the nitrates is explained by the following examples :

Common Names.	Formulae.	Systematic Names.
Hydrated nitric acid	HNO^3	Hydra nitrite
Nitrate of potash (saltpetre)	KNO^3	Potassa nitrite
Nitrate of soda (cubic nitre)	NaNO^3	Natra nitrite
Nitrate of barytes	BaNO^3	Baryta nitrite
Nitrate of oxide of silver	AgNO^3	Argentia nitrite

Composition of hydrated nitric acid by weight :

1 atom of hydrogen	H =	1 =	·016
1 atom of nitrogen	N =	14 =	·222
3 atoms of oxygen	O ^s =	48 =	·762
		63	1·000

In what manner the three atoms of oxygen are distributed between the hydrogen and the nitrogen, with which they constitute hydrated nitric acid, it is impossible to determine. The assumption that hydrated nitric acid = HNO^s , contains anhydrous nitric acid, a compound which I have described at page 293, under the formula NNO^s , is quite groundless. No evidence exists to prove that in this acid, and in the nitrates generally, five-sixths of the oxygen is combined with the acid radical, and one-sixth of it with the basic radical. Somebody's *ipse dixit* is the only authority. We are therefore under no obligation to believe in the theory that a *nitrate consists of an acid and a base*, and if we consider it as a question of expediency, we find that, in the present condition of chemical philosophy, the theory is inconvenient and unsatisfactory, and that the only thing which can be said in its favour is, that it is an established error, which people have believed in for half a century, and which they continue to believe in from deference to antiquity, and simply because it was believed in by generations of chemists who have now passed away. That is the ground of their faith.

DOCTRINE OF THE ANHYDRIDES.

I take the opportunity which is presented by this point, of saying a few words respecting the constitution of the anhydrous acids, or as they are now often called, the "anhydrides."

I have described a salt to be a compound in which an acid radical is combined with a basic radical, either with or without oxygen. See page 122. But besides the salts which occur of that normal character, we find other salts, in which acid radicals act the part of basic radicals, under condition of being supplied with a certain excess of oxygen. This observation disagrees considerably with the doctrine that oxygen, in agreement with the etymology of its name, is *the acid-former*. We must, however, be guided in this matter, not by an etymology which was founded on a misapprehension, but by the facts which investigation discloses and proves to be true. We will examine a few of these facts. I cannot go deeply into the subject, and indeed it is needless to do so here, because I have discussed it fully in my *Treatise on the Radical Theory*.

Examples.	Hydrated Acids.	Corresponding Anhydrides.
Nitric acid	H,NO^3	N,NO^5
Sulphuric acid	H,SO^2	S,SO^3
Phosphoric acid	H,PO^3	P,PO^5
Acetic acid	$H,C^2H^3O^2$	$C^2H^3,C^2H^3O^3$
Tartaric acid	$H,C^2H^2O^3$	$C^2H^2,C^2H^2O^5$
Benzoic acid	$H,C^7H^5O^2$	$C^7H^5,C^7H^5O^3$

The compounds in the column of Hydrated Acids may fairly be called *salts consisting of two radicals*, the basic radical being, in every case, hydrogen. This hydrogen is replaceable in every instance by a metallic radical, or by a basic radical of any description, without the least derangement of the constitution of the salts, even when the replacing metal is one of those which gives double equivalents. Thus:—

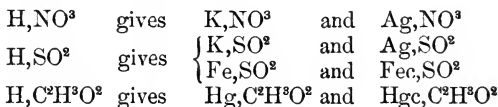

Exactly the same relationship continues when the replacing radicals belong to the compound organic class, provided always, that the radicals thus brought into action are essentially basic in their normal characters. Hence,

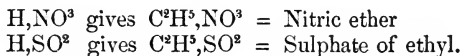

When, however, we come to examine the cases in which the replacing radical is one which usually acts as an acid radical, then we find that this acid radical never acts as a basic radical, that is to say, never replaces the basic hydrogen of a hydrated acid, without carrying into the new compound such an additional quantity of oxygen as totally changes the character of the compound. Thus, when H,NO^3 exchanges H for N, the oxygen rises from three atoms to five atoms; and when H,SO^2 exchanges H for S, the oxygen rises from two atoms to three atoms. Upon examining the last column of the little table of six examples cited above, it will be seen that when a normal salt contains two atoms of oxygen its anhydride contains three atoms, and that when the normal salt contains three atoms of oxygen, its anhydride contains five atoms.

This requirement of additional oxygen to qualify an acid radical to play the part of a basic radical, or so to speak, to compensate for its deficiency in basic power, is not peculiar to the anhydrous acids, where only *one kind of radical* is present, but occurs also in cases where the radicals are of *different kinds*, of which the following examples afford sufficient evidence.

Examples of Mixed Acids.

Corresponding Anhydrides.

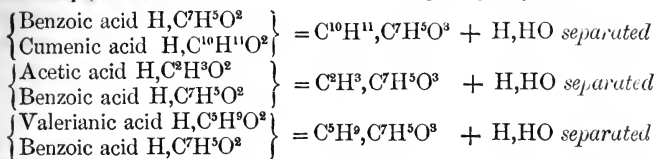

These examples show that when mixed hydrated acids are acted upon chemically so as to separate water, the results are precisely similar to those which occur when single acids are acted upon. The new salts contain in all cases, with *two radicals*, a greater quantity of oxygen than is the property of their normal salts. The concurrent evidence of these various examples proves, that when acid radicals act the part of basic radicals, they take up an additional dose of oxygen, one atom or two atoms, according to their normal habitudes; and that the so-called anhydrous acids, or anhydrides, are merely salts of an abnormal nature, in which acid radicals act as basic radicals, under the controlling influence of additional oxygen. The notion that these anhydrous acids are ingredients in hydrated acids must be abandoned unconditionally by those who adopt the radical theory, or who admit the atomic weight of oxygen to be coincident with the specific gravity of its gas. If the atomic weight of oxygen is admitted to be 16, while that of hydrogen is fixed at 1, the existence and constitution of the anhydrides is sufficient to disprove, once and for ever, the doctrine that "salts are composed of acids and bases;" for NNO^5 cannot *possibly* form *part* of HNO^3 . Upon the determination of the atomic weight of oxygen rests, therefore, in a great measure, the settlement of this long-pending discussion respecting the proximate constitution of the salts. I, for one, am clearly of opinion that the atomic weight of oxygen is 16, and that salts contain neither anhydrous acids nor anhydrous bases.

PROPERTIES OF THE NITRATES.

The neutral nitrates are all soluble in water, so that they give no precipitates unless they contain precipitable bases. They are all decomposed by sulphuric acid, and by heat, and they all deflagrate with red-hot charcoal. See page 58. A few basic nitrates, that is to say, nitrates with excess of bases, are partly insoluble in water.

Generally speaking, the nitrates are monobasic, but a few terbasic and bibasic salts are known, as are also some peculiar double salts of which nitrates are constituents. I refer the reader for an account of them to my work on the Radical Theory.

Detection of Nitric Acid and Nitrates. See page 91.

Direct Production of Nitrates.—1). Oxygen and nitrogen can, in the

presence of water, or of water and a powerful basic radical, be made to combine, by the influence of the electrical spark, into a nitrate.

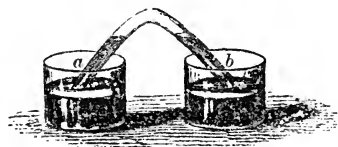

298.

To prove this fact, it is necessary to arrange an apparatus in the form shown by fig. 298. The U-shaped tube, filled with mercury, is placed in two troughs, also filled with mercury. You pass into the knee of the tube a quantity of air and a little solution of caustic pot-

ash. The mercury of one vessel is then put into connection with an electrical machine, and that of the other vessel, by means of an iron chain, with the earth. The electrical machine is put into continuous action for a considerable time, and after a great number of sparks have been passed, it will be found that the solution of potash contains a certain quantity of nitrate of potash.—*Regnault*.

2). Pass a current of ammoniacal gas, mixed with an excess of atmospheric air, through a glass tube that contains spongy platinum. No reaction takes place at the ordinary temperature of the air, but when the platinum is heated, it gradually becomes red-hot, and produces vapours of nitric acid mixed with nitrous acid. If the platinum is too strongly heated, it produces nitrous acid only. If an excess of ammonia is used, nitrate of ammonia is produced.—*Kuhlmann*.

PREPARATION OF HYDRATED NITRIC ACID.

Nitric acid is prepared by distillation from any of the following mixtures.

1. Purified nitre, 100 parts; oil of vitriol, 100 parts.

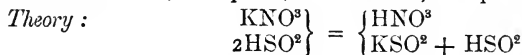

2. Purified nitre, 100 parts; oil of vitriol, 50 parts.

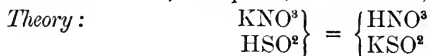

3. Purified nitrate of soda, 100 parts; oil of vitriol, 60 parts.

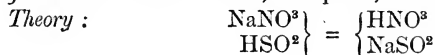

4. Purified nitrate of soda, 100 parts; oil of vitriol, 120 parts; water, 30 parts.

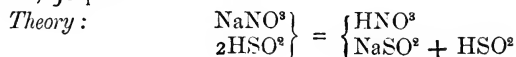

When only so much sulphuric acid is taken as barely suffices to decompose the nitrate, there always occurs a partial destruction of the nitric acid, and though the product is strong, the nitric acid is mixed with nitrous acid. When there is a double quantity of sulphuric acid, so that the metallic salt remains in a state of a bisulphate, there is much less loss of nitric acid, and the product contains less nitrous acid but more water.

Whichever of these mixtures is preferred, the salt in coarse powder is put into a plain retort, the capacity of which must be twice as great as the bulk of the mixture. The neck of the retort is wiped clean by a cloth tied on a stick, a long acid funnel, fig. F, 299, is put into it,

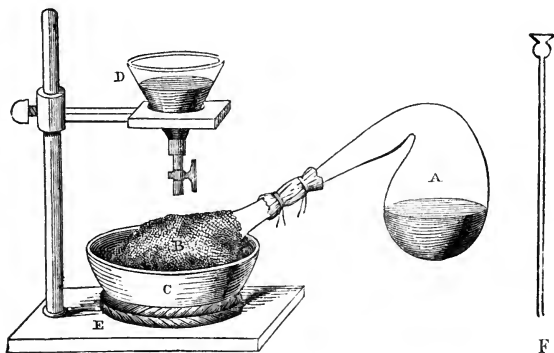

299.

and the sulphuric acid is poured through, so as to pass into the body of the retort without soiling its neck. The retort is then to be inclined in such a manner that the funnel can be withdrawn without dropping the least acid on its neck. The retort is to be connected with a large globular receiver, the neck of which must grip the retort as close as possible, for no cork must go between them. A moderate heat is to be applied by means of a sandbath placed over a lamp or gaslight, and the temperature should never exceed 260° . The receiver must be covered with a cloth, B, and be well cooled by a stream of cold water run on it continuously, as represented by fig. 299, letter D. For large quantities, the apparatus shown by fig. 300 is useful. A is the retort, contained in a sandbath placed in a portable furnace. B is a globular receiver covered with a net, the use of which is to spread the cold water over its whole surface. This receiver must be very large and have a short neck, in order that the beak of the retort may pass into the middle of the receiver. C is a trough with cold water, & the pipe that supplies the

cold water. The apparatus represented by fig. 301 is very convenient for affording a current of water in such operations. *c, d,* represent a stool,

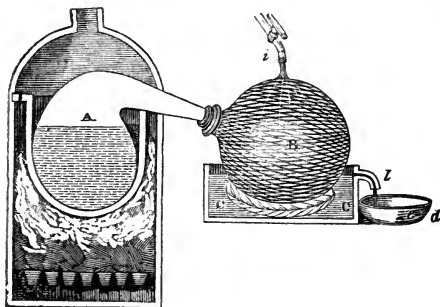

300.

the height of which can be regulated to suit the elevation of the distilling apparatus. *a* is the water bottle, and *b* the stopcock to regulate

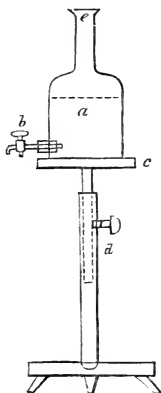

301.

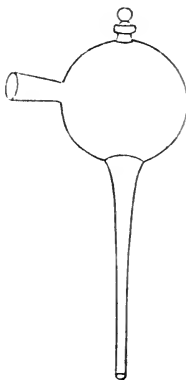

302.

the supply. Fig. 302 shows a *quilled receiver*, which is sometimes used in the distillation of nitric acid. The neck of the retort is passed through the side neck of the receiver, and the long spout is put into a bottle or vertical receiver, plunged up to its neck in cold water.

A small quantity of nitric acid may be prepared, merely to illustrate the process, by means of the tube retort and receiver, shown in

fig. 303. The materials are put into the retort, *a*, without soiling the neck, the bent part of the receiver, *d*, *b*, is dipped into cold water, and

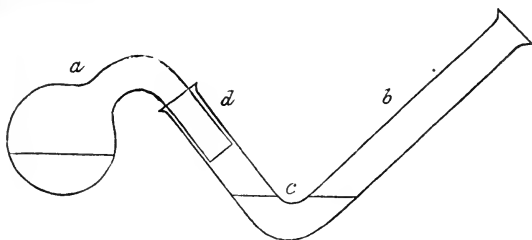

303.

a cold-water tube is put into the branch *b*, as shown at page 213. The nitric acid is collected at the bend *c*. A support for this apparatus is described at page 76, and another at page 162.

The first tenth part of the total quantity of acid which the materials can afford in any distillation, is to be first collected and set apart. It contains muriatic acid and other impurities. When the drops of acid that fall from the neck of the retort do not precipitate a solution of nitrate of silver, pure nitric acid will be coming over, and may be collected in a clean receiver. The distillation is continued as long as any acid comes from the retort. Towards the end of the distillation the acid again becomes less pure. When the retort is nearly cold, warm water may be put into it, to dissolve the salt that remains (bisulphate of potash or sulphate of soda).

Fuming Nitric Acid is a mixture of nitric acid and nitrous acid. It is produced when nitre is distilled with only half the usual quantity of oil of vitriol. See preparations Nos. 2 and 3, page 298. In examples Nos. 1 and 4, an extra quantity of hydrated sulphuric acid is used, in order to leave the alkali in the retort in the state of a bisulphate. In that case, only common nitric acid is produced, but the process is more economical, because the product of nitric acid is much greater, none of it being decomposed to afford the nitrous acid necessary to convert the ordinary nitric acid into fuming nitric acid.

Impurities contained in commercial Nitric Acid.—*Nitrous Acid*, known by its yellow colour. Separable in part by boiling in a retort, when nitrous acid and a little nitric acid distil over together. *Chlorine*; gives a precipitate with solution of nitrate of silver. Separable like nitrous acid by boiling in a retort. *Sulphuric Acid*; gives a precipitate when diluted and tested with solution of nitrate of barytes. Separable by re-distillation with a little additional nitre. Or when chlorine is also present, the nitric acid may be diluted to sp. gr. 1.42, precipitated

with nitrate of silver and nitrate of barytes, decanted and distilled. *Iodine*; Neutralise the nitric acid with potash, add a little starch, and then sulphuric acid drop by drop slowly. A blue colour is produced. *Fixed substances* are detected by evaporating a little of the acid to dryness. Pure nitric acid is entirely volatile.

Preparation of concentrated Nitric Acid.—We obtain nitric acid at its highest degree of concentration, by mixing acid of sp. gr. 1.448, for example, with 5 parts of concentrated sulphuric acid, and distilling at a temperature not above 300° F. There goes over nearly nine-tenths of the weight of the nitric acid employed, at sp. gr. 1.52, which we may distil as often as we please with sulphuric acid without causing any further alteration.

We can in this manner concentrate the Nitric Acid of commerce.—After one or two distillations, we obtain acid of the density of 1.52.

To take away the Yellow Colour.—The acid thus prepared has sometimes a yellow colour, but it arises more from the influence of the light than of the sulphuric acid. To render it colourless, it is only necessary to add a little peroxide of lead. The nitrate of lead produced is insoluble in the acid, and falls to the bottom.

PROPERTIES OF NITRIC ACID.—A colourless fuming liquid decomposable by light; odour, pungent and peculiar; taste, excessively sour and corrosive; it colours litmus red; acts very destructively on organic bodies; communicates a yellow colour to such as contain nitrogen, for example, the human nails and skin, also feathers, horn, silk, wool, cork, and indigo. When concentrated it abstracts water from the atmosphere. Its specific gravity is about 1.521. Most commonly it is of a yellow colour, in consequence of containing nitrous acid.

The following Table shows the composition of the most important compounds of nitric acid with water.

NITRIC ACID. TABLE A.

Test Atom $\text{HNO}^3 = 63$ grains:

Specific Gravity of the Acid.	Per Centage of Acid of 1.5.	Grains of HNO^3 in 1 Septem.	Test Atoms of HNO^3 in 1000 Septems.	Septems containing 1 Test Atom of HNO^3 .	Septems containing 1 lb. of the Acid.	Grains of HNO^3 in 1 lb. of the Acid.	Money Value of 1 lb. of the Acid.
1.	2.	3.	4.	5.	6.	7.	8.
1.521	Aq ^A	10.647	169.	5.92	657	7000	1.07
1.5	100	9.7633	155.	6.45	667	6512	1.00
1.498	99	9.6528	153.2	6.53	668	6447	.99
1.496	98	9.5425	151.5	6.6	668	6382	.98
1.494	97	9.4325	149.7	6.68	669	6317	.97
1.492	96	9.3165	147.9	6.76	671	6252	.96
1.488	95	9.2009	146.	6.85	672	6186	.95
1.473	90	8.6288	137.	7.3	679	5861	.90
1.4518	Aq ^B	7.895	125.3	7.98	688	5432	.83
1.4385	80	7.4903	118.9	8.41	695	5210	.80
1.42	Aq ^C	6.9636	110.5	9.05	704	4902	.75
1.3978	70	6.3686	101.1	9.89	715	4558	.70
1.3477	60	5.2632	83.54	11.9	742	3907	.60
1.2947	50	4.2135	66.88	15.	772	3256	.50
1.2341	40	3.213	51.	19.6	810	2605	.40
1.1709	30	2.2854	36.28	27.6	854	1954	.30
1.1403	25	1.8555	29.45	34.	877	1628	.25
1.1109	20	1.4461	22.95	43.6	900	1302	.20
1.0821	15	1.0565	16.77	59.6	924	976	.15
1.054	10	.686	10.88	91.9	949	651	.10
1.0267	5	.3341	5.3	189.	974	325	.05
1.0106	2	.1316	2.09	478.	989	130	.02
1.0053	1	.0654	1.04	962.	995	65	.01

The acid of specific gravity 1.5, which is the foundation of the above table, with the exception of the three hydrates, contains, according to Dr. Fre, 79.7 per cent. of anhydrous acid, and 20.3 per cent. of water. It is not the hydrate denoted by HNO^3 , which is equivalent to—

Anhydrous Acid . 85.71
 Water 14.29,

and is marked in the table as specific gravity 1.521, hydrate Aq^A.

There are three definite hydrates, marked in the table Aq^A , Aq^B , Aq^C . These are as follows :

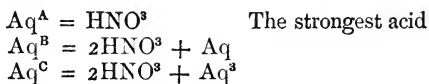

This last compound is the acid that distils without alteration of strength. Its boiling point is 248° F. A stronger acid is weakened by boiling, and a weaker acid is strengthened by boiling, till both come to sp. gr. 1.42 , or the strength of 110 test atoms per decigallon, when the maximum boiling point of 248° F. occurs. The commercial liquor termed *aquafortis* is weak and impure nitric acid. *Single aquafortis* has commonly a strength of about 50 test atoms per decigallon, and *double aquafortis* a strength of about 90 test atoms. When strong nitric acid is diluted with water, condensation is effected, and heat is disengaged. Acid of sp. gr. 1.521 mixed with snow produces heat. Acid of sp. gr. 1.42 mixed with snow produces cold.

The table shows a variety of particulars respecting diluted nitric acid, which are interesting, both in a chemical and a commercial sense. I have used the term test atom to signify an atomic weight expressed in English grains, and I have marked the bulk in septems of the test atom of each solution to make evident how much by measure of any given diluted acid must be taken to obtain a specific quantity, namely, an equivalent, or 63 grains of actual acid. Column 5 shows this atomic measure for each solution. These measures are all equivalent in chemical strength to each other. They each represent 63 grains of HNO^3 ; so that by dilution in a test mixer any strong acid may be readily and exactly reduced to the strength of any of the weaker acids. 6.45 septems of acid of 155 atoms reduced with water to the bulk of 100 septems produces acid of 10 atoms. See the general notice of Centigrade Testing, commencing at page 97 of this work.

Columns 6, 7, and 8 of Table A relate chiefly to commercial matters. Liquid acids and liquid ammonia are sold by *the pound*, and it is consequently necessary to understand the relation between chemical testing according to measure, and money value according to weight. In column 8, it is assumed that the money value of nitric acid is fixed in relation to the acid of sp. gr. 1.5 . Of course all other acids are worth less and less according to the falling off in the proportion of real acid which they contain, as shown by column 7. Thus, if acid of 155 atoms is worth 1.00 , then acid of 66.88 atoms is only worth $.50$, because one pound weight of it only contains half as much HNO^3 as one pound weight of the former acid.

But this relation of money value to the absolute quantity of acid is true only at the place of manufacture; so that when the acid is to be transported to a distance, another element must come under considera-

tion. Thus, taking, for example, the same two acids, column 5 shows that the *same quantity of acid* which, when of the strength of 155 atoms, fills 6.45 carboys, will, when of the strength of 66.88 atoms, fill 15 carboys. Hence the cost of carboys, freight, and charges incidental to the transport of acids, rises in the proportion of nearly two to five; a fact which intimately concerns the money value of the acid at any distance from the place of manufacture.

The method of estimating the strength of acids by chemical testing is so much more accurate than that by the use of the hydrometer, that for laboratory use, the chemist may depend solely upon it, and neglect to observe the specific gravity of his solutions. The following Table of the strength of nitric acid includes only purely chemical considerations, and is so constructed as to enable the chemist to tell readily the strength of any given sample of acid, and to prepare by dilution acids of any other power required for a special purpose.

NITRIC ACID. TABLE B.

Test Atom HNO³ = 63 grains.

Grains of HNO ³ in 1 Septem.	Test Atoms of HNO ³ in 1000 Septems.	Septems containing 1 Test Atom of HNO ³ .	Grains of HNO ³ in 1 Septem.	Test Atoms of HNO ³ in 1000 Septems.	Septems containing 1 Test Atom of HNO ³ .
10.647	169.	5.92	6.93	110.	9.09
10.584	168.	5.95	6.615	105.	9.52
10.521	167.	5.99	6.3	100.	10.
10.458	166.	6.02	5.67	90.	11.1
10.395	165.	6.06	5.04	80.	12.5
10.332	164.	6.1	4.41	70.	14.3
10.269	163.	6.13	3.78	60.	16.7
10.206	162.	6.17	3.15	50.	20.
10.143	161.	6.21	2.52	40.	25.
10.08	160.	6.25	1.89	30.	33.3
9.765	155.	6.45	1.575	25.	40.
9.45	150.	6.67	1.26	20.	50.
8.82	140.	7.14	.945	15.	66.7
8.19	130.	7.69	.63	10.	100.
7.875	125.	8.	.315	5.	200.
7.56	120.	8.33	.126	2.	500.
7.245	115.	8.7	.063	1.	1000.
1.	2.	3.	1.	2.	3.

In the papers and tables which I have formerly published in relation to centigrade testing, and in which I employed the atomic weights of

Berzelius, fixing oxygen at 100, and water at 112.48 , that acid which I recommended for centigrade testing, and which I called *acid of 100 degrees*, was equal to $12\frac{1}{2}$ test atoms of the present scale. In many cases I recommended acid of half that strength, equal to $6\frac{1}{2}$ test atoms of the present scale. This relation applies to all the acids. What I now propose to do, having adopted a new scale of atomic weights, to which these broken numbers do not conveniently apply, is to adopt as a general standard for acid and alkaline solutions, liquors which contain *five test atoms per decigallon*. A solution of that strength is readily prepared by diluting one atomic measure, or one test atom, of an acid, to the bulk of 200 septems, or five test atoms to the bulk of 1000 septems, as shown by the table. In some instances, acids of the strength of 10 test atoms in a decigallon may be used; but, for general testing, liquors of 5 test atoms per decigallon will be found most convenient. The Table on page 305 shows that nitric acid of this strength contains $.315$ grain of HNO^3 in every septem.

It rarely happens that the strength of an acid, as found by experiment, agrees exactly with any acid that is quoted in the tables. That would often happen if the tables were enlarged to ten times their present extent. But such occurrences offer no obstacle to the use of this system of testing. Let it be supposed, for example, that you test a specimen of aquafortis, and find its strength to be *85 test atoms per decigallon*. This gives the number required for column 2 in TABLE B. To find the number for column 1, you have only to multiply 85, the number of test atoms in a decigallon, by 63, the number of grains of acid constituting 1 test atom; the product which you obtain is 5355. This is the number of grains of HNO^3 contained in 1000 septems, and when pointed to 5.355 , it expresses the weight of acid which is present in 1 septem.

To find the atomic measure of the acid, the number that is required for column 3 of Table B, it is necessary to divide 1000 by the ascertained number of test atoms, which in this case is 85; the product is the number required for the table, namely, $1000 \div 85 = 11.8$. But the easiest way to find this number is to seek it in a table of reciprocals, which I give for that purpose in page 307. Of course this table of reciprocals serves equally well for all test liquors. Referring to 85 in the series of numbers, you find against that number in the column of reciprocals the number 11.8, which is the required atomic measure of this particular acid, or that number of septems which contain one test atom of that acid of which 1000 septems contain 85 test atoms. This completes the numbers required for a line of Table B. If you want the relations that are shown by columns 1, 2, 6, 7, 8, of Table A, then determination of specific gravity must be made, and calculations proceed thereon. Here, again, the table of reciprocals comes sometimes into

action; for example, the figures in column 6 of Table A, are the reciprocals of the numbers in column 1, and the figures in column 5 are the reciprocals of those in column 4.

Determination of the strength of Nitric Acid by Centigrade Testing.

Preparation of Nitric Acid of special degrees of strength.

These two subjects have been fully explained in the general article on Centigrade Testing. See page 110.

OXIDISING POWER OF NITRIC ACID.—Although nitric acid is one of the strongest acids, it is very liable to suffer decomposition, giving off its oxygen to other combustible substances. It is what is called a *powerful oxidising agent*, and it is therefore proper to examine what this term signifies.

a). Heat a little sublimed sulphur with strong nitric acid in a glass tube. Effervescence takes place, red fumes of peroxide of nitrogen are formed, and the sulphur disappears. The liquor in the tube then contains sulphuric acid, and may be tried by the proper tests for that acid.

Theory :

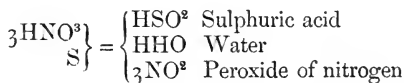

b). In a similar manner, phosphorus can be converted into phosphoric acid.

c). Upon a quantity of granulated tin, pour concentrated nitric acid, a little at a time. Red fumes appear, and the tin is converted into a white oxide, but it does not dissolve; for when tin is oxidised, it becomes permanently insoluble in acids, unless at the instant of production it is in the presence of a quantity of acid and water sufficient for its solution.

Theory :

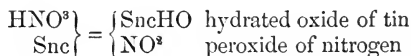

d). Galena, or black sulphide of lead, reduced to fine powder, is to be heated in a small flask with strong nitric acid. Red fumes appear, and after a time the black powder is changed to a white powder. PbS is converted into PbSO², or sulphate of lead; the necessary oxygen being abstracted from a portion of decomposed nitric acid. This product is insoluble in water.

Theory :

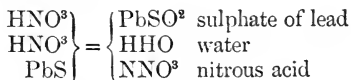

e). Litharge is dissolved in nitric acid without the production of red fumes. The solution, mixed with a little sulphuric acid, such as that produced in experiment a, gives a white precipitate similar to the insoluble product of experiment d.

Theory :—The reason that no red fumes are produced in experiment *e* is, that litharge is an *oxide* of lead, and therefore is capable of dissolving in nitric acid without further oxidation. In consequence, we avoid the *waste of acid* that occurs when substances require to be oxidised by the acid previous to solution.

First reaction.

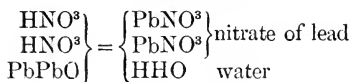

Second reaction.

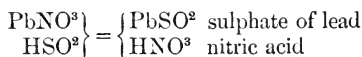

f). Solution of copper in nitric acid. See pages 41 and 289.

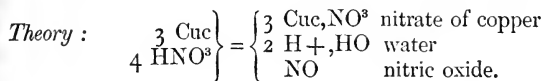

g). Into a little nitric acid put a piece of chalk, or carbonate of lime. Effervescence and solution take place, but the gas given off is not in red fumes.

Theory :—In this case, therefore, the nitric acid is not decomposed. The gas given off is carbonic acid from the chalk, and the lime, or oxide of calcium, combines with the nitric acid, and forms nitrate of lime.

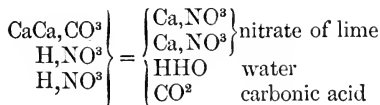

h). Oil of turpentine poured into strong nitric acid bursts into flame. This experiment should be performed in the open air; the acid must be put into a gallipot, and the turpentine be held in a bottle tied to the end of a long stick. A little oil of vitriol should be mixed with the nitric acid.

Theory :—The reactions in this case are too complicated to be readily explained in an equation. I cite the experiment as one which proves the energy with which nitric acid can act, rather than as one which affords important theoretical conclusions.

i). Many other organic bodies—wool, feathers, wood, indigo, &c.—can be decomposed or greatly changed in constitution by the action of nitric acid. Some of these will come under our notice in other sections.

NITRIC ACID CONSIDERED AS A SOLVENT.

Next to water, nitric acid is the solvent which is most generally useful. There are few substances which do not yield to its energetic action, and as nearly the whole of its compounds are soluble in water, they are well adapted for presentation to the action of re-agents.

Things to be observed regarding this Solution.

1.) Different effects are produced by nitric acid when used of different degrees of concentration, or when acting at different temperatures. A metal dissolved in diluted and cold nitric acid produces a solution of *protonitrate*, or *nitrate of the basylous radical*. The same metal dissolved in concentrated and hot nitric acid, yields a solution of *per-nitrate*, or *nitrate of the basylic radical*. Earths, oxides, and salts generally dissolve more readily in diluted than in concentrated nitric acid.

2.) In effecting the solution of any substance in nitric acid, it is necessary to avoid superfluous acid. To do this, you take care to add to the solid which is to be dissolved, not too much acid at a time. If too much acid is added inadvertently, it should be expelled from the solution by subsequent evaporation.

3.) *Carbonic Acid Gas* is disengaged with effervescence during the solution of carbonates in diluted nitric acid. Commonly, the solution is effected in cold acid, but several native crystallised carbonates and strongly calcined carbonate of barytes, dissolve only in warm and moderately strong nitric acid. Carbonic acid gas is colourless and inodorous, and reddens litmus.

4.) *Sulphuretted Hydrogen Gas* is disengaged during the solution of sulphides. This gas has a strong and disgusting odour.

5.) *Hydrogen Gas* is disengaged during the solution of iron and some few metals in diluted nitric acid. This gas differs from others here produced, by want of colour, of odour, and of action on litmus paper.

6.) *Nitrous Acid Gas in red fumes* is disengaged during the solution of many metals and other oxidable substances.

7.) *Chlorine Gas* (pale green) is disengaged in company with nitrous acid gas when chlorides are heated with strong nitric acid.

8.) *Violet Vapours of Iodine* are disengaged in like manner from iodides.

9.) *Brown Vapours of Bromine* in the same way from Bromides.

10.) The solution of the substance may be *partial*. What remains undissolved may be an admixed insoluble substance, such as the matrix of a mineral, or an adulterant, such as heavy spar in white lead; or it may be a product of the operation, as boracic acid, produced by the decomposition of a borate; oxide of tin, produced by the oxidation of metallic tin; sulphur, separated from a sulphide; silicia, separated from a siliceous mineral, and so on.

11.) Concentrated solutions, upon cooling, frequently *deposit salts* in crystals, which redissolve upon the addition of water.

12.) The addition of water to clear solutions of bismuth and proto-nitrate of mercury, *precipitates* a subsalt, unless a sufficient excess of nitric acid is present.

13.) The *colour* of the solution sometimes indicates the metal which it contains. Thus, a clear blue indicates copper, red indicates cobalt, green indicates nickel, and so on. See page 212.

14.) The *neutrality* of the solution is to be tried with test papers. It can only be perfectly neutral when the dissolved substance is an alkaline earth or an alkali, and has been used in sufficient quantity to saturate the nitric acid. All metals and all non-alkaline earths produce solutions possessing an acid reaction.

15.) The characters of a number of substances which dissolve in nitric acid are so very equivocal that they are liable to be readily mistaken for other substances. There are certain phosphates, borates, sulphates, arseniates, arsenites, and chromates, which do not dissolve in water, and the solutions of which substances in nitric acid behave towards alkaline precipitants much in the same way that the metallic oxides producible by the bases of the same insoluble salts behave towards the same re-agents. Hence these insoluble salts are apt to be mistaken for their mere bases, and their acids are liable to be overlooked.

Substances Soluble in Diluted Nitric Acid.

Acid diluted with twice its bulk of water.

Metals. All such as are readily oxidised.

Alkaline Earths.

Earths proper. Except after they have been strongly ignited.

Metallic Oxides. Except the oxides of Tin and Antimony.

Peroxides partially. Thus, Peroxide of lead partly dissolves, and partly precipitates as peroxide of lead. The addition of sugar to the hot acid prevents this precipitation by reducing the peroxide.

Siliceous Minerals. A good many suffer decomposition when heated in diluted nitric acid. The base dissolves and the silica is deposited in a gelatinous form,

and can be rendered insoluble by evaporation to dryness.

Salts of Non-metallic Oxygen Acids, which do not dissolve in water, such as Phosphates, Borates, and Carbonates, basic and neutral.

Salts of the Metallic Acids.

Chlorides, }
Bromides, } Most of those which do not
Iodides, } dissolve in water, both
Fluorides, } basic and neutral.

Sulphides. All such as give sulphuretted hydrogen gas when treated with diluted acids.

Substances Insoluble in Diluted Nitric Acid.

Metals which are oxidised with difficulty.
Sulphur, Selenium, Charcoal.

Peroxides of Tin, Antimony, Titanium, and Iron, after strong ignition.

Earths proper, after strong ignition.

Peroxides of Metals, many.

Sulphides. Most of those which are in-

soluble in water, excepting those of Manganese, Iron, and Zinc.

Metallic Acids which do not dissolve in water, namely the acids of

Tungsten. Antimony.

Titanium. Tantalum.

Silicon.

Barytes, the sulphate and seleniate.
 Strontium, ditto, but less completely.
 Lime, ditto, but partially soluble.
 Silver, chloride, bromide, iodide, cyanide.
 Fluorspar.
 Lead, the sulphate, slightly soluble.

Mercury, the *protochloride*, bromide, and iodide.

Siliceous Minerals, most of them.

Salts of Metallic Acids, the acids insoluble, but the basic radicals abstracted by the nitric acid.

Substances Soluble in Concentrated Nitric Acid.

Sp. gr. not below 1.25.

All substances that dissolve in diluted nitric acid, excepting compounds of lead and barium, the nitrates of which metals are insoluble in concentrated nitric acid.

All Metals, except Gold, Platinum, Iridium, Rhodium, and Cryst. Titanium, which do not oxidise, and Tin, Antimony, and pulverulent Titanium, which produce solid white oxides.

Sulphur, which slowly produces sulphuric acid.

Selenium, which produces selenic acid.

Sulphides,
 Selenides,
 Phosphides,

{ All those of which the metals produce soluble nitrates, except the sulphide of mercury, and those which produce insoluble sulphates, such as the sulphides of barium, strontium, calcium, and lead, which are for the most part deposited in the solution in the state of sulphates. The two last can be dissolved by a large addition of water.

Chlorides,
 Bromides,
 Iodides,
 Cyanides,

{ All those that do not dissolve in diluted nitric acid.

An abundance of nitrous acid in red fumes, is disengaged during these solutions in concentrated nitric acid. Heat requires to be applied with circumspection, and the acid to be added in small portions, else the resulting action is apt to become inconveniently violent. To witness this vigorous disengagement of nitrous acid fumes, you have only to add to hot and concentrated nitric acid in a flask, finely divided (as in foil or in powder) iron, copper, zinc, bismuth, tin, metallic sulphides or arsenides, or any other easily oxidisable substance.

Whenever heat is applied, which rarely is necessary when fuming nitric acid is employed, the application of it must be gradual and moderate. Boiling must be avoided, else the strong acid will evaporate rather than act upon the substance you wish it to dissolve.

When metallic sulphides are dissolved in strong nitric acid, a portion of the sulphur, perfectly freed from its metal, is deposited in the solution. This sulphur can be wholly converted into sulphuric acid by prolonged digestion with strong nitric acid, but it is commonly better to abridge that operation, and to separate the precipitated sulphur from the solution by filtration, whenever the clear yellow colour of the sulphur gives reason to think that all its metal has been abstracted from it.

Substances Insoluble in Concentrated Nitric Acid.

Tin,
 Antimony,
 Titanium,

{ and their oxides.

Gold,
 Platinum,
 Iridium,

{ Rhodium.
 Charcoal.
 Peroxides of metals.

Calcined non-alkaline earths.

Calcined peroxide of Iron.

Metallic Acids. Such as do not dissolve in water.

Barytes, sulphate and seleniate.

Strontian, sulphate and seleniate.

Lead, sulphate and seleniate.

Fluorspar. Cinnabar.

Fluosilicide of Barium.

Siliceous Minerals, many, particularly of those which contain an excess of silica.

Salts of Metallic Acids. Such as are insoluble in water.

When the Nitric Acid is concentrated in the highest degree and is colourless, it will then not dissolve several metals which in other states it easily acts upon, namely, copper and iron.

NITRITES AND NITROUS ACID.

The composition of nitrous acid has been explained at page 291. The nitrites are salts in which the basic hydrogen of the hydrated nitrous acid has been replaced by a metallic radical. Examples :

HNO^2 hydrated nitrous acid
 KNO^2 nitrite of potash
 AgNO^2 nitrite of silver.

The nitrite of potash is obtained when nitrate of potash is exposed to heat in a retort. Oxygen goes off, and nitrite of potash remains. See page 166. The residue of the operation there described is digested in alcohol, which dissolves nitrite of potash KNO^2 , but not nitrate of potash KNO^3 . If the solution of nitrite of potash is mixed with a solution of nitrate of silver AgNO^3 , we obtain a precipitate of nitrite of silver AgNO^2 ; nitrate of potash KNO^3 remaining in the solution.

The nitrites are an unimportant class of salts.

AMIDOGEN, AMMONIUM, AMMONIA.

The radical nitrogen combines with other radicals to produce compound basic radicals. In doing this, it controls the affinities of those other radicals to such an extent that their ordinary saturating capacities are totally paralysed, and remain paralysed as long as the combinations endure. This power of control nitrogen exercises in two degrees.

First degree.—ONE atom of nitrogen combines with TWO radicals to form a triple compound, which may be represented by the formula NMM , which compound, consisting of three radicals, has a saturating power equal of that of one radical; in other words, the saturating capacities of the two radicals MM are paralysed, and the radical N alone retains its saturating power.

Second degree.—ONE atom of nitrogen combines with FOUR radicals to form a quintuple compound, which may be represented by the formula NMMMM ; which compound, consisting of five radicals, has a saturating power equal to that of one radical; so that here the saturating capacities of four radicals are paralysed.

The symbol M in these formulæ signifies hydrogen, or any metal, or any hydrocarbon which has, separately, the properties of a radical, either positive or negative; but the metalloids Cl , Br , I , the element oxygen, and all nitrogenous compounds are excluded from the number of the radicals that can combine with nitrogen to produce the two orders of compound radicals which are now under consideration. This exclusion is strictly insisted upon, because many chemists allow themselves a very great and very injurious licence in this particular.

The compound radicals NH^2 and NH^4 , and their equivalents NM^2 and

NM^4 , cannot exist alone, but each of them has extensive powers of combination, and each can be readily converted into the other. I have treated of these compounds at great length in my work on the Radical Theory, and I can only touch here upon the more important particulars.

AMIDOGEN.—This is the name commonly given to the radical NH^2 .

AMMONIUM.—This is the usual name of the radical NH^4 .

Both radicals are subject to change their hydrogen for other radicals, and produce many varieties of *vice-radicals*, which have the same saturating capacity as the normal radicals.

Examples.

NH^2 produces NHM . NMM .
 NH^4 produces NH^3M . NH^2M^2 . NHM^3 . NM^4 .

In each case M may be either a metal or a hydro-carbon.

I propose to give to the compounds formed on the model NH^2 , the name of *Amids*, and to those formed on the model NH^4 the name of *Ammons*.

As amidogen and ammonium do not exist in an isolated state, we can only study them in the condition of salts. I shall treat of the salts of the former under the head of Ammonia, and of the latter under the head of Ammonium, among the basic metallic radicals.

AMMONIA.

Synonymes, The Volatile Alkali, Spirit of Sal Volatile, Spirit of Hartshorn. *Formula*, NH^2, H . *Atomic weight*, 17. *Specific gravity of gas*, 8.5. *Atomic measure*, 2 volumes.

Occurrence.—In sal ammoniac; in coal tar; in the urine of animals, especially of birds and reptiles; in guano; in most animal substances, bones, horns, feathers, &c.; in a few minerals; and in the air of the atmosphere in small quantity (about one volume of ammonia in twenty-eight millions of volumes of air).

Properties.—In the gaseous state it is colourless and transparent; has a powerful stinging odour; is unfit for respiration, and destructive of animal life; has a strong alkaline taste; gives a brown colour to turmeric paper, which vanishes in the air; is reducible by cold and pressure to the state of a thin colourless liquid; dissolves rapidly and in great quantity in water and in alcohol; is very slightly combustible; does not support the combustion of other bodies. When mixed with acid gases, it forms thick white clouds. The specific gravity of its gas is 8.5. Its chemical equivalent is 17. Hence its atomic measure is two volumes. Its ultimate constitution is three volumes of hydrogen and one volume of nitrogen.

Ammonia is commonly called a *base*. It is more correct to call it a *SALT*, and to consider its components to be the radical amidogen = NH^2 , and the radical hydrogen = H .

The radical amid = NH^2 , and the salt ammonia = NH^2, H , are subject to have part or the whole of their hydrogen replaced by compound radicals. The following are examples:—

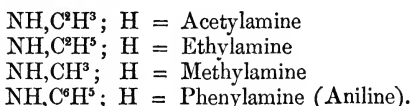

These salts may all be considered as the equivalents of ammonia; they are volatile, and they each possess an atomic measure of two volumes. But similar compounds exist which contain metals or other non-volatile radicals, and which do not form gases.

Example:—The amid of potassium = NHK ; H . This is converted by water into caustic potash and ammonia.

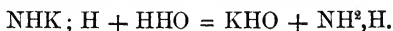

Compounds of Ammonia.—Ammonia, as I have said, is a salt, and not a radical. It is the hydride of amidogen. In the state of gas, its atomic measure is two volumes, which in itself is almost a proof, and certainly affords a strong presumption, that it is a compound of two radicals.

When ammonia goes into combination, it does not combine as a basic radical with an acid radical to produce a simple salt, but it combines as a complete salt with another complete salt to produce a compound salt. The consequence is, that the volatile double salts which are formed by ammonia have in all cases an atomic measure of four volumes, because each double salt contains four radicals. The only exceptions among the gaseous ammoniacal salts to this atomic measure of four volumes are where the salts possess radicals which lose their measure in combination, as, for example, is the case with sulphur. Examples of these double salts are given in the table of gases at page 142. Let us examine sal-ammoniac, or the hydrochlorate of ammonia, as a model of this series of compounds. Its formula is $\text{NH}^2, \text{H} + \text{H}, \text{Cl}$. We have here the whole materials of two salts, the hydride of amidogen, which of itself is known to measure two volumes, and the hydride of chlorine, or hydrochloric acid, which also is known to measure two volumes. These two salts, known to exist separately, and each having the measure of two volumes, combine without condensation to produce the double salt, *the hydrochlorate of hydride of amidogen*, which has consequently an atomic measure of four volumes, because it is a compound of four radicals, none of which possess *the powers of condensation*, which I have described at page 138, as characteristic of certain other radicals. In the compound

$(\text{NH}^2 + \text{H}) + (\text{H} + \text{Cl})$ there is no condensation, except that which is exercised by nitrogen in the production of the radical NH^2 .

All this seems to be intelligible.

But upon this explanation there follows a difficulty. When sal ammoniac is brought into the state of solid crystals, it forms a compound which, in its form, and in many of its chemical characters, closely agrees with the salt that is called chloride of potassium. Now, chloride of potassium is considered to be a direct compound of potassium with chlorine, a *binary* compound in accordance with the formula KCl ; and we have to account for the peculiar circumstance, how it is that a compound of two radicals, a simple salt = KCl , should appear to be the counterpart of a salt, the gaseous properties of which indicate it to be a double salt of the formula $\text{NH}^2, \text{H} + \text{H}, \text{Cl}$. The only rational explanation of this difficulty seems to be, that the radicals which constitute sal ammoniac form in fact, under different circumstances, two *different salts*. In the gaseous state, they produce a double salt, the *hydrochlorate of hydride of amidogen* = $\text{NH}^2, \text{H} + \text{H}, \text{Cl}$; and in the solid and aqueous states the elements undergo re-arrangement and produce a simple salt = the chloride of ammonium, NH_4, Cl . In other words, the gaseous salt contains amidogen, and the solid salt contains ammonium. In the solid state, the governing power of the nitrogen is exercised over H^4 ; in the gaseous state, it is restricted to H^2 . Admitting the facts that the salts of the vice-amids are frequently volatile, while those of the vice-ammoniums are invariably fixed, this explanation is quite in accordance with our experimental evidence, and approaches as nearly to demonstration as circumstantial evidence can be reasonably expected to do.

Gerhardt's Ammonia Type.

Gerhardt, and after him Hofmann and other eminent chemists, have explained the constitution of ammoniacal compounds by reference to a formula which is called the ammonia type. I consider the doctrine to be fallacious and injurious. In my work on the Radical Theory, I have examined it in detail. I avoid it here entirely because explanation is impossible without the introduction of multitudinous details.

PREPARATION OF AMMONIA GAS.

1.) Put liquid ammonia into a flask, and heat it. The gas is rapidly disengaged.

2.) Take one part of sal ammoniac and one part of quicklime, each separately powdered. Mix them intimately by a rapid pounding in a mortar and introduce them into a glass flask. Apply a gentle heat, and the gas will soon be evolved. If this gas is conveyed into water, it is rapidly absorbed: the water acquiring the properties of what is known by the name of *liquid ammonia*. The gas cannot, therefore, be

collected over water. It may be collected over mercury, or less accurately by the displacement of air.

Theory of the production of Ammonia :—

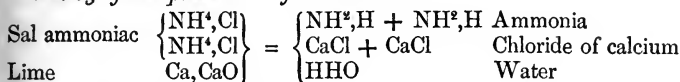

Method of drying Ammonia Gas.—The sal ammoniac and lime are put into the flask *a*, figure 304, the receiver *b* is empty, and the tube *c*

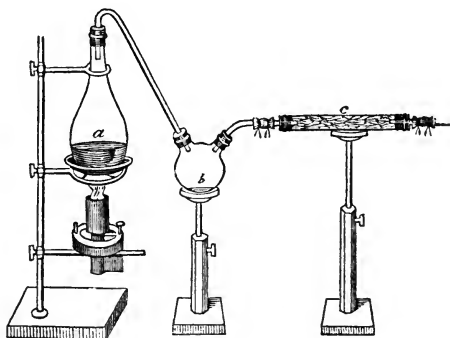

304.

is filled with lumps of fused caustic potash. Heat being applied, the operation proceeds. Part of the water is condensed in the receiver *b*, and the rest is absorbed by the potash in the tube *c*. Chloride of calcium cannot be used to dry this gas, because the two compounds act chemically upon one another. The ammonia gas escapes from the potash tube *c* in a perfectly dry state, and is ready to be collected over mercury.

Collection over Mercury in Cooper's Receiver.—This method of collecting the gas is shown in figure 306, where, however, the intermediate drying apparatus is not represented; *a* is the flask in which the ammonia is prepared; *dd* is Cooper's Mercurial Receiver, which may be 12 inches long, and three-quarters of an inch wide; *b* is the gas leading tube; and *ef ef* are two tube-holders, similar to figure 55, page 76, by which the vessels are held together in suitable positions. At the beginning of the operation, the receiver *dd* is filled with mercury, and a basin is placed below the mouth of it, to catch the mercury as it is displaced by the gas. The operation is stopped when the gas fills the tube nearly to the bend.

In figure 306, letters *d d* do not represent the best form of Cooper's gas tube. Figure 305 shows it more accurately.

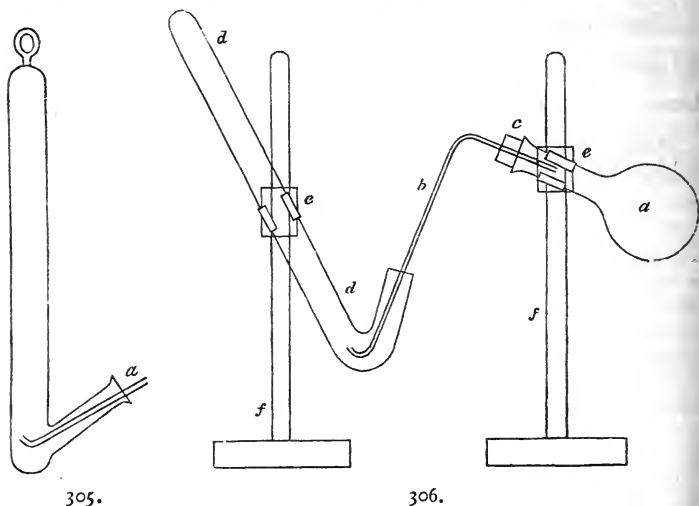

Mercurial Trough.—Figures 307 and 308 represent a horizontal and a vertical section of a stoneware mercury trough, which can be worked

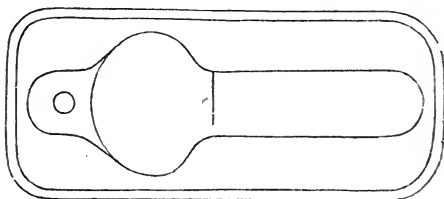

307.

with five lbs. of mercury, and be used with gas cylinders as large as six inches long, and one inch in diameter. There should be a set of six or

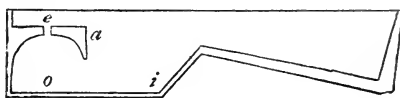

308.

eight cylinders, from the size just mentioned down to one inch in length

by one-third of an inch in width. These should be made of strong glass tubes, smooth or ground on the edge, and some of them graduated to show hundredths or tenths of a cubic inch, or divisions such as are recommended at page 141. See figures 111, 112, 113. The trough is placed for use in a flat earthenware pan, figure 309, to catch any mercury that may flow over its edge, and there must be at hand a few porcelain trays, figure 310, one inch and a quarter in diameter, in which to lift tubes filled with gas, and confined by a little mercury. See page 168. In using this trough, the gas tube is filled with mercury and inverted over the shelf, *a*, figure 308. The point of the gas-delivering tube is put under the shelf at *o*, upon which the gas rises through the hole, *e*, and fills the tube placed above it. The tube when filled with gas can be slid off the shelf into the little tray, and set aside while other tubes are being filled in succession.

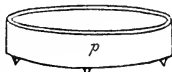

309.



310.

Figure 311 represents a complete apparatus for operating in this manner. Letter *a* represents a hard German glass tube, about one

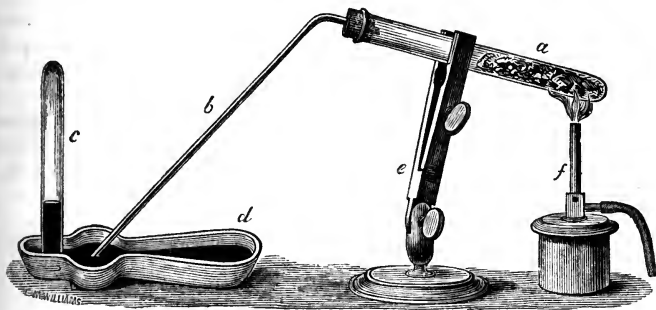

311.

inch wide and six or seven inches long, containing the mixture that is to generate the ammonia gas; *b* is the gas-delivery tube; *c* is a glass receiving tube, filled with mercury, and inverted in the mercurial trough *d*. This trough agrees in section with figure 308, but only with the interior lines in figure 307. The outer lines in figure 307 represent a raised addition to the mercury trough, intended to prevent the overflow of mercury when the rising gas expels the metal from the receiving tube. That overflow is, however, of no consequence when the trough is placed, as it always ought to be, in a pan, like figure 309. Letter *e* represents a form of wooden tube-holder which is very convenient in such operations as the present. *f* is a gas burner to supply the heat

required to effect the liberation of the gas. It is supported on a wooden block.

Collection of Ammonia Gas by displacement of Air.—Gases that are lighter than atmospheric air, such as ammonia, can be collected in a



312.

state of sufficient purity for some experiments as follows:—The gas-delivery tube is made narrow, long, and quite straight, and passes directly upwards from the gas bottle, as shown in figure 312. The gas receiver is brought over this tube, and forced down till the tube touches the top of the receiver. The light gas escaping from the tube, settles at the upper part of the receiver, and as its quantity increases, it gradually depresses the atmospheric air, and finally drives it wholly from the receiver. By holding a slip of wet turmeric paper, or red litmus paper at the mouth of the jar, you easily ascertain when it is full of ammonia, because the test paper then changes colour. The yellow turmeric turns brown, the red litmus becomes blue. A jar that is to be filled in this manner may be supported by a perforated plate of tin or glass, figure 313, laid on the ring of a retort stand. The gas-delivering tube is put up

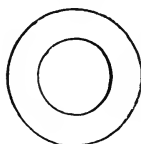

313.

through the hole in the plate. Gases thus collected may be secured by shallow trays containing a little mercury, or by plates of greased glass, or in bottles with greased glass stoppers or sound corks. But they always contain a certain admixture of atmospheric air.

When a globular flask, of the form shown in figure 316, is thus to be filled with ammonia, the gas-delivery tube must be long enough to reach to the top of the globe when it is held in the inverted position shown by the figure.

EXPERIMENTAL ILLUSTRATIONS OF THE PROPERTIES OF AMMONIA.

A. *Its Solubility in Water.*

- 1.) A gas tube or small stout jar filled with the gas, and standing



314.



315.

in a tray full of mercury, as shown in figure 314, is depressed into a basin of water, until the mouth of the tube is below the surface of the water. The jar is then lifted from the mercury in the tray, upon which the water rushes up into the jar with violence, and if the gas is pure it disappears entirely. One measure of water dissolves above 600 measures of gas. If the water is previously slightly reddened by litmus it turns blue after the absorption of the gas. If the jar is not of very stout glass, it is sometimes broken by the violence of the concussion. For that reason it should be held with a cloth, as shown in figure 315. The presence of a bubble of atmospheric air diminishes the violence of the shock.

2.) A globular bottle is filled with ammonia gas, and is stopped by a cork traversed by a narrow glass tube, having a very small opening at the end put within the bottle. The external end of the tube is put into red litmus water, upon which the water produces a jet or fountain in the bottle: see figure 316. The bottle ought to be chosen of stout glass, to give it strength to stand the shock of the water. But when the gas is put into it by displacement, there is always present as much admixture of atmospheric air as suffices to moderate the action of the water.

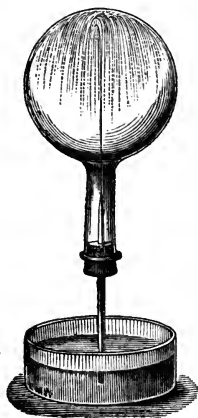

316.

3.) Displace a little mercury from the open end of Cooper's Receiver, figure 305, and fill the space with a few drops of water. Close the mouth of the tube with your thumb, and incline the tube so as to pass a little of the gas, bubble by bubble, into the water. The gas disappears instantly. Red litmus paper, dipped into the resulting solution, becomes blue, and the solution will be found to have the smell and taste of liquid ammonia. Remove the liquor with a pipette, carefully dry the tube with blotting paper folded on a wire, and fill up the receiver with mercury, taking care to prevent any water passing into the body of the tube, else the whole gas will be absorbed.

4.) Other experiments can be made with Cooper's Receiver, by bringing small quantities of the gas successively into the short tube for trials. To do this, the short tube is filled with mercury, and closed with the thumb, and then the long tube is inclined so as to throw a little of the gas into the short tube, from which an equivalent bulk of mercury passes at the same moment back into the long tube.



317.

5.) A tube full of ammonia being on the shelf, *a*, of the trough, figure 308, a tube of the size of figure 317 is filled with reddened water and put into the mercury, so that the mouth

of the tube goes down to the space, *o*. The trough is widened at *i* in front of the shelf to admit the finger and thumb of the experimenter, to manage the tube for this purpose. The tube being forced down into the space, *o*, *i*, the water rises from it through the hole, *e*, the gas is absorbed, and the mercury rises to fill the tube. The tube used to contain the ammonia for this experiment must be of very stout glass, and the trough should be previously filled with mercury.

6.) If a bit of ice is passed up into ammonia gas confined over mercury, the ice melts immediately, and rapidly absorbs the ammonia.

B. It extinguishes flame, but is slightly combustible.

7.) Try it in the same manner as hydrogen gas. See page 199. It will be seen that the flame is much enlarged before it is extinguished, showing the combustibility of the ammonia.

8.) Close the mouth of Cooper's Receiver with the thumb, bring round into the short limb a small quantity of gas, and insert an inflamed splinter of wood, the light of which will be extinguished.

9.) Ammonia gas issuing from a narrow tube, if inflamed in a jar containing oxygen gas, burns continuously with a yellow flame.

C. It combines with acid gases.

10.) Warm a small flat-bottomed porcelain capsule, put into it a few drops of muriatic acid, and set over it a tube full of ammonia gas, in the manner shown by figure 314, given in experiment 1. The tube will immediately be filled with a dense white fume. In this experiment, muriatic acid gas and ammonia gas combine and form solid sal ammoniac.

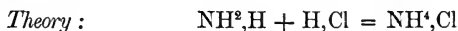

11.) A glass rod dipped in hydrochloric acid and held over a vessel from which ammonia is escaping, manifests its presence by a white cloud.

12.) If carbonic acid gas and ammonia gas are mixed together, they condense into a solid white compound, the carbamate of ammonia. Four volumes of ammonia always condense with two volumes of carbonic acid.

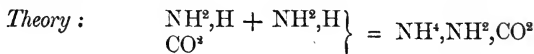

13.) Some liquid nitric acid is put into a porcelain acid-holder, figure 319, and some strong liquid ammonia into a capsule, figure 318. The latter is set upon the former, and the whole covered with a bell glass shade, see figure 292. White fumes soon appear, but these gradually diminish, and at the end of two days the acid-holder, 319, will contain crystals of nitrate of ammonia, and the capsule, 318, a

weak solution of nitrate of ammonia, that salt being produced by the combination of the hydrated nitric acid with the ammonia.

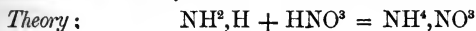

318.

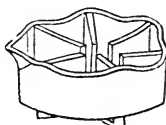

319.

D. Anhydrous Ammonia in the liquid state.

Ammonia can be liquefied by exposure to a cold of -40°F. , and more readily by generating it under pressure. Expose chloride of silver in the state of dry powder to a current of dry ammoniacal gas. The powder takes up the gas and increases one-third in weight. Put this powder into one end of a strong bent glass tube, figure 320, and seal the tube hermetically. Then heat that end of the tube which contains the powder, *a*, and cool the other end with a



320.

freezing mixture. After some time a liquid will appear at the cold end of the tube *b*. This is pure anhydrous ammonia. It is a colourless liquid, which, at 60°F. exerts a pressure of $6\frac{1}{2}$ atmospheres, and has a specific gravity of 0.73 . At the reduced temperature of -103°F. ammonia is frozen to a white translucent crystalline solid, denser than the liquid. If heat and cold are removed from the tube, the chloride of silver again absorbs the ammonia and reproduces the original dry powder.

It is remarkable that the specific gravity of condensed ammonia under $6\frac{1}{2}$ atmospheres is very nearly the same as its density in aqueous solutions under ordinary atmospheric pressure at the same temperature.

FORMATION OF AMMONIA BY INDIRECT PROCESSES.

a.) Mix 40 grains of fine iron filings with 2 grains of caustic potash, and distil the mixture in a small test tube fitted with a narrow gas-delivery tube; figure 311 on a small scale. After separation of the atmospheric air, hydrogen gas will be disengaged. Compare process *f*, page 196.

b.) In the same manner, 40 grains of fine iron filings are to be distilled with 2 grains of saltpetre. The gaseous product of this decomposition is nitrogen.

c.) Combine these two experiments. Distil 80 grains of fine iron

filings with 2 grains of caustic potash and 2 grains of saltpetre. The gaseous product in this case is ammonia.

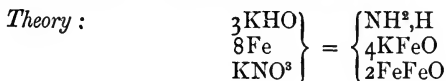

Another method. Hydrogen gas and nitrous oxide gas are to be collected in separate gas-holders, and are to be passed thence, in the proportion of 8 volumes of the former to 2 volumes of the latter, into water contained in a three-necked Woulff's bottle, to be there mixed together. A third tube carries the mixed gases into a wash bottle, from which they pass into a long porcelain tube kept at a red heat in a tube furnace, as exhibited at page 197. The gas which passes out of the heated tube contains a quantity of ammonia.

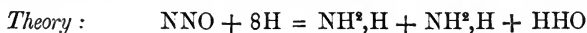

Third method. Zinc put into very dilute nitric acid discharges hydrogen gas and produces nitrate of zinc.

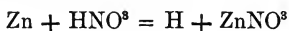

If zinc is put into very concentrated nitric acid, part of the nitric acid is decomposed and nitrogen and oxides of nitrogen are set free.



If acid of mean strength is taken, the effects are combined, but the nitrogen acts on the hydrogen and produces ammonia. The effect is greater if sulphuric acid is present. Dissolve zinc in diluted sulphuric acid; add nitric acid drop by drop until hydrogen gas ceases to be given off. The zinc then continues to dissolve without disengagement of hydrogen, and there will be found in the solution a quantity of sulphate of ammonia.

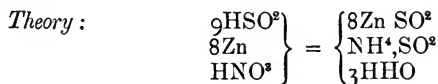

The combination of nitrogen with hydrogen under these circumstances is termed *combination in the nascent state*.

ANALYSIS OF AMMONIA.

1. Two volumes of ammonia gas exposed in a closed vessel to a great number of electrical sparks is entirely decomposed; its quantity is increased to four volumes, and these on examination are found to consist of one volume of nitrogen and three volumes of hydrogen.

2. If dry ammonia gas is passed through a porcelain tube which contains pulverised quicklime, and is heated to redness, the ammonia is completely decomposed, and two volumes of it produce a mixture of one volume of nitrogen and three volumes of hydrogen.

3. If eight volumes of the mixed gas produced by the above experiments are put into an eudiometer tube, with four volumes of oxygen, and the mixture is fired by an electric spark, nine volumes will disappear. If three volumes of hydrogen are then added, and the mixture again is exploded, three volumes will disappear.

Explanation of the first explosion.

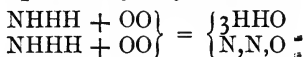

Explanation of the second explosion.

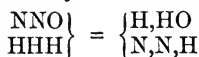

The condensation in the first explosion indicates three volumes of oxygen and six volumes of hydrogen. In the second explosion it indicates one volume of oxygen and two volumes of hydrogen. There remain two volumes of nitrogen and one volume of hydrogen. The second explosion is made only to determine how much oxygen was added in excess for the first explosion.

4. A solution of nitrite of ammonia is decomposed by heat into water and pure nitrogen.

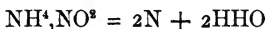

5. Nitrate of ammonia is decomposable by heat into water and nitrous oxide. See page 288.

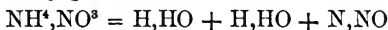

EXTRACTION OF AMMONIA FROM ANIMAL SUBSTANCES.

Manufacture of Spirits of Hartshorn, Bone-black, &c.—This experiment affords an example of what is called *dry distillation*. It requires the apparatus that is represented by figure 321. The retort *a* is a tube of hard Bohemian glass, about half or three-fourths of an inch in diameter, and about ten inches long. The receiver *b* is chosen barely wide enough to go over the neck of the retort. The junction is made with a bored cork or a caoutchouc connector. The bends of the two tubes are made at such angles that when the closed branch of the retort is placed in a horizontal position, the receiver shall be in the position shown by the figure. Each branch of the receiver should be about six inches long; but it is immaterial if one of the branches is longer than the other, as shown in the figure. Letter *c* is a gas-delivery tube, con-

nected to *b* by a cork; *d* is a pneumatic trough; *e* a tube to collect gas over water; *f* a wooden support.

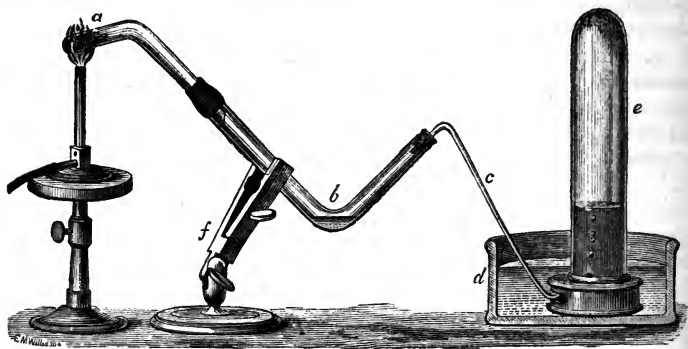

321.

About an ounce of dry clean bones, coarsely pounded with a hammer, are put into the retort *a*; as much water is put into the receiver *b* as merely covers the bend; water is put into the trough *d*, and into the gas receiver *e*; the whole apparatus is put together as shown in figure 321, and the heat of a small gas light or a spirit lamp is applied to the retort.

Gas speedily passes through the water in the receiver *b*, and rises in the gas jar *e*. The bones become black, the water in *b* becomes brown, and a dark-brown oil soon collects on the surface of the water in that branch of the receiver which is farthest from the retort. The heat may be continued until gas ceases to pass through the water in the receiver, and the bones appear to be thoroughly charred.

Examination of the products of the Distillation.—The gas collected in *e*, and the water and oil in *b*, will be found to have a disgusting odour, and will remind the experimenter of the atmosphere which prevails in the agreeable neighbourhood of bone boilers and manufacturers of ammonia and bone black. The gas is a mixture of combustible gases and readily burns with flame. The water and oil may be partially separated by filtration through a filter previously wetted with water. This bone oil, prepared in the large way, is used to burn in lamps to produce *lamp black*, which is soot deposited during an imperfect combustion.

The filtered water has a brown colour, because it retains part of the bone oil, and therefore still stinks. It will, however, be found to contain *carbonate of ammonia*, which may be proved as follows:—

- a.) It smells of ammonia.
- b.) It turns yellow turmeric paper brown, and makes red litmus blue.

c.) Put a little of the water into a test glass, and add lime water. This will precipitate carbonate of lime, and leave free ammonia in the liquid, when the effects *a* and *b* will become more distinct.

d.) To the rest of the water add muriatic acid till the mixture becomes neutral to test papers. Carbonic acid will be discharged with effervescence, and the mixture will then contain muriate of ammonia, which may, by careful evaporation, be obtained in the solid state, but stained brown by a residue of bone oil.

The black residue is now to be shaken out of the retort and ground in a mortar to fine powder. In this condition it is *bone black*, or *animal charcoal*, a substance which has the property of removing colour from various substances, and also of destroying putrefaction; as will be referred to in the section on carbon.

Put a little of this bone black into a flat iron spoon, held by a pair of tongs, and heat it strongly over a spirit lamp. The charcoal will burn away and you will obtain a white powder. This is *bone ash*, or phosphate of lime.

The facts developed by this simple set of experiments serve as the basis of several large branches of chemical manufacture. They prove also the existence in bones of the following elements:—Phosphorus, calcium, carbon, nitrogen, hydrogen, and oxygen. These elements being present in the products of the decomposition of bones, were necessarily present in the undecomposed bones, under peculiar forms of combination.

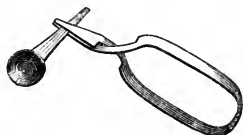

322

LIQUID AMMONIA.

Solution of Ammonia Gas in Water.—We have seen that ammonia gas dissolves abundantly in water. One volume of water takes up according to the temperature 500 or 600 volumes of gas. The solution is colourless, and intensely alkaline. The taste is extremely caustic. It blisters the skin if applied to it in a concentrated state. Simple exposure to the air causes an escape of the gas, so that the liquid has always a pungent odour. It is very dangerous to put the nose to a bottle of liquid ammonia, and smell it incautiously; for if the liquor happens to be strong, the vapour instantly stops the power of breathing, and produces a painful and dangerous feeling of suffocation.

Ammonia has the remarkable property of possessing the same bulk in all its combinations with water. It neither expands nor condenses in consequence of combining with, or being diluted by, water; in which property it differs essentially from the fixed alkalies and the liquid acids. The relations of ammonia to water are extremely simple. Every test atom, or 17 grains of ammonia, which is passed into water, displaces

or expels 24 grains of water. The difference of these numbers being 7 grains, it follows that if this process takes place upon a fixed bulk of water, such as a decigallon, the addition of every test atom of ammonia, admitting it to expel 24 grains of water, diminishes the weight of the whole residual mass by 7 grains, and the effect of this is to diminish the specific gravity of the solution by one in the third place of decimals. Thus, water being fixed at 1.000, as representing 7000 grains per decigallon, the weight of a solution which contains one test atom of ammonia is $7000 - 7 = 6993$ grains; and its specific gravity is $1.000 - .001 = .999$. The substitution of ammonia for water can proceed at this rate until the solution acquires the chemical strength of 125 test atoms per decigallon, and a specific gravity of .875. That is the limit of saturation at the temperature of 62° F., and under the ordinary atmospheric pressure. The constitution of liquid ammonia of any intermediate strength is in accordance with these data.

The number which expresses the specific gravity, written to three places of figures between the extremes of .999 and .875, added to the number which expresses the chemical degree, or the number of test atoms per decigallon, between the limits of 1° and 125° , in all cases are together equal to 1000. So that the chemical strength or the specific gravity of any solution of ammonia can each be easily deduced from the other. If S represents the specific gravity of a sample of liquid ammonia, and C its chemical strength expressed in test atoms, then —

$$1000 - S = C$$

$$1000 - C = S.$$

The chemical strength is the *difference* between the specific gravity and 1000; and in like manner the specific gravity is the *difference* between the chemical strength and 1000.

The weight of a decigallon of the strongest solution of ammonia, of specific gravity .875, is 6125 grains ($= .875 \times 7000$). The weight of the ammonia contained therein is 2125 grains ($= 17 \times 125$). The difference between 6125 and 2125 grains is 4000 grains, which is the weight of the water. But a decigallon of water at the same temperature (62° F.) contains 7000 grains. It follows that when water is converted into solution of ammonia, it expands to the extent of 75 per cent; 4000 measures of water produce 7000 measures of ammonia, or 100 measures produce 175 measures.

SOLUTION OF AMMONIA IN WATER.

Test Atom $\text{NH}^2, \text{H} = 17$ Grains. Temperature 62°F .

Specific Gravity of the Solution.	Test Atoms of NH^2, H in 1000 Septems.	Septems containing 1 Test Atom of NH^2, H .	Per Centage by Weight of NH^2, H .	Grains of NH^2, H in 1 Septem.	Grains of NH^2, H in 1 lb. of Solution.	Septems containing 1 lb. of Solution.	Money Value of 1 lb. of Solution.
.875	125	8.	34.7	2.125	2429	1143	1.05
.876	124	8.07	34.4	2.108	2407	1142	1.04
.877	123	8.13	34.1	2.091	2384	1140	1.03
.878	122	8.2	33.7	2.074	2362	1139	1.02
.879	121	8.26	33.4	2.057	2341	1138	1.01
.880	120	8.33	33.1	2.040	2317	1136	1.00
.881	119	8.4	32.8	2.023	2296	1135	.991
.882	118	8.48	32.5	2.006	2275	1134	.981
.883	117	8.55	32.2	1.989	2254	1133	.972
.884	116	8.62	31.9	1.972	2230	1131	.962
.885	115	8.7	31.6	1.955	2209	1130	.953
.890	110	9.09	30.	1.870	2102	1124	.907
.895	105	9.52	28.5	1.785	1994	1117	.861
.900	100	10.	27.	1.700	1889	1111	.815
.905	95	10.5	25.5	1.615	1785	1105	.770
.910	90	11.1	24.	1.530	1681	1099	.726
.915	85	11.8	22.6	1.445	1579	1093	.681
.920	80	12.5	21.1	1.360	1478	1087	.638
.925	75	13.3	19.7	1.275	1378	1081	.595
.930	70	14.3	18.3	1.190	1279	1075	.552
.935	65	15.4	16.9	1.105	1182	1070	.510
.940	60	16.7	15.5	1.020	1085	1064	.468
.945	55	18.2	14.1	.935	989	1058	.427
.950	50	20.0	12.8	.850	895	1053	.386
.955	45	22.2	11.4	.765	801	1047	.346
.960	40	25.	10.1	.680	709	1042	.306
.965	35	28.6	8.8	.595	616	1036	.266
.970	30	33.3	7.5	.514	562	1031	.243
.975	25	40.	6.2	.425	436	1026	.188
.980	20	50.	5.	.340	347	1020	.150
.985	15	66.7	3.7	.255	259	1015	.112
.990	10	100.	2.5	.170	172	1010	.074
.995	5	200.	1.2	.085	85	1005	.037
.998	2	500.	.5	.034	34	1002	.015
.999	1	1000.	.2	.017	17	1001	.007

Explanation of the Table of Solutions of Ammonia.—The composition of a series of important aqueous solutions of ammonia is represented in the Table on page 229.

The nature of the facts which are shown by the different columns have been fully explained, either in the preceding notice of ammonia, or in the description of the parallel tables of solutions of nitric acid that was given at page 304. In comparing the money value of the different solutions of ammonia, I have taken as a standard, not the strongest possible solution at 62° F., but the strongest solution of commerce, namely that of sp. gr. 0.88. Solutions stronger than that cannot be prepared for sale economically, because of the facility with which, at the slightest rise of temperature, they give off ammonia in the state of gas.

Determination of the chemical strength of Liquid Ammonia.

Determination of the strength of Ammonia by the Ammonia-meter. (Hydrometer).

Preparation of Liquid Ammonia of particular degrees of strength for testing and other purposes.

These three subjects have been sufficiently explained in the general article on Centigrade Testing. See page 109.

PREPARATION OF SOLUTION OF AMMONIA IN WATER.

Preparation in small quantities.—The best way to prepare a small quantity of *liquid ammonia* is the following:—A little pure water is put into a U-tube, and the U-tube is plunged into cold water mixed with ice, contained in a beaker glass, as represented in figure 323.

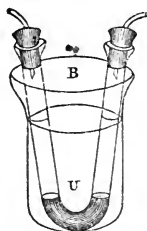

323.

The water must not exceed the third part of the capacity of the tube, because it expands from 100 to 175 volumes when saturated with ammonia. The gas-delivering tube which brings the ammonia from the gas bottle, such as *b*, figure 311, is connected by a sound cork with one end of the U-tube, and the other end of the tube is closed by a cork traversed by a very narrow tube open at each end. Ammonia gas is then to be *very slowly* passed into the U-tube. The water rises into the opposite branch of the U-tube, and by its pressure causes a rapid absorption of the gas. When the ammonia gas bubbles freely through the liquor and escapes by the narrow tube, the water will be saturated, by which time the solution will be expanded till it nearly touches the cork containing the narrow tube, and the strength will be greater than that of the strongest solution in the preceding table. If the solution, thus saturated at 32° F., is put into a glass in a warm room and allowed to rise in temperature to 62° F., it will give off gas under ebullition, and finally acquire the strength of 125° or specific gravity 0.875. Even at this strength, the application of a warm hand,

or the too-close approach of the operator's face to the vessel containing the ammonia, causes it to boil and discharge gas. This is the reason why it is not expedient to prepare liquid ammonia for sale of greater strength than 120° , or specific gravity 0.88.

When very pure liquid ammonia is required, the U-tube is to be connected with the V-tube, the latter either being filled with pieces of caustic potash, or containing a little of a strong solution of caustic potash, and the ammonia gas is to be slowly passed through the V-tube to be purified before it is passed into the U-tube for absorption.

To prepare strong Liquid Ammonia from weak Liquid Ammonia.—Put part of the ammonia into the U-tube and the rest into a gas bottle. Connect them together, and by a very gentle heat drive the ammonia from the gas bottle into the U-tube.

By the above processes, strong and pure liquid ammonia can be easily prepared from the liquid ammonia of commerce, when quicklime may not happen to be at command.

Preparation of Liquid Ammonia in large quantities.—A large globular flask *k* in figure 325, is half filled with an intimate mixture of well pounded sal ammoniac and unslacked lime in equal portions. A



324.

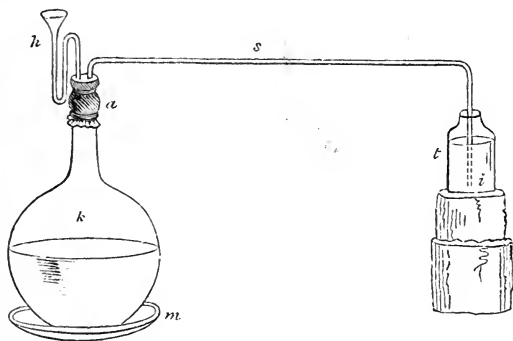

325.

bent gas-leading tube *s*, and a bent acid funnel *h*, are passed through a cork, and the cork is adapted to the neck of the ballon by an envelope of caoutchouc, figure 135, tied on so as to secure an air-tight junction. The other end of the tube *s* is passed into the bottle *t*, which is to be two-thirds filled with cold water. The point of the tube reaches to the bottom of the flask, because the solution of ammonia being lighter than

water, rises to the surface. One pound of water may be taken for every pound of sal ammoniac, but the water must be put into a number of small equal-sized bottles; because, as the gas condenses, the water becomes heated, and is then unfit to absorb more gas. As fast, therefore, as each bottle becomes warm, it must be exchanged for another bottle containing cold water, and be placed aside where it can be cooled. From time to time, small quantities of water are poured into the ballon *k*, through the funnel *h*. The combination of this water with the lime produces heat, and occasions a rapid disengagement of the ammonia gas. When this action ceases, heat may be applied to the sand-bath *m*, and gradually increased until the thick mixture in the ballon boils, and then is to be sustained until the gas ceases to be disengaged. Very pure ammonia is yielded by this process,—the empyreumatic substances contained in the sal ammoniac being less decomposed than they usually are when the sal ammoniac and quicklime are heated to fusion without water.—*Mitscherlich*.

As it sometimes happens that the necks of large gas bottles, to which several glass tubes require to be adapted, are of irregular form, so that round corks or other stoppers do not fit them air-tight, it may be useful to show in what manner such a difficulty can be overcome. In some cases, where only a low pressure of gas is exerted, the caoutchouc caps represented in page 179 are a sufficient remedy. In other cases the following process is more effectual. The neck *a* of the bottle *k*, in fig. 325, is closed by a stopper made of the mineral called serpentine, in which have been drilled two or three holes to fit the required glass tubes. The stopper, with its tubes, is fixed in the mouth of the bottle, and a cylindrical jacket, made of paper or caoutchouc, is tied round the neck of the bottle. See fig. 326. A paste is then made by stirring powdered plaster of Paris with milk, starch-water, or thin glue. This paste is poured into the jacket above the stopper, so as to cover the holes through which the glass tubes are passed. It immediately hardens and forms a cement, which effects a perfectly air-tight junction.



326.

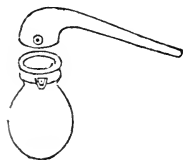

327.

Ammonia gas can also be prepared in a porcelain retort, made as represented in the figure. Round the neck of the body, there is a deep groove into which the cover dips. When the materials have been put into the body, the groove is filled with plaster of Paris mixed with water, the head is then put in its place, and the plaster hardens so as to form an effective lute. On each side of the retort and head is a pair of corresponding ears, which may be fastened together with thumb-screws, or tied firmly with soft flexible iron wire.

Tests of the purity of Liquid Ammonia.—1. When evaporated to dryness in a glass capsule, it should leave no solid residue.

2. If it gives a precipitate with lime water, it contains carbonic acid.

3. Neutralise it with pure nitric acid, and test it as follows:—If a white cloud is produced with a solution of nitrate of silver, it indicates the presence of chlorine.

4. If diluted nitrate of barytes produces a white precipitate, it indicates sulphuric acid.

5. A white precipitate with oxalate of ammonia indicates lime.

6. A brown or black precipitate with sulphuretted hydrogen shows copper or lead.

The solution ought never to be kept in bottles that contain lead in their composition.

Uses of Liquid Ammonia.—It is employed by the chemist to neutralise acids, and to precipitate insoluble bases. As the residual ammonia and most of its salt can be volatilised by heat, it communicates no fixed impurity to the solutions. It is much employed in medicine, and is the best antidote to the poison of prussic acid.

Precipitates produced in Solutions of Salts by Liquid Ammonia.

WHITE PRECIPITATE:—Magnesia, if the solution is neutral. Alumina. Glucina. Ytria. Thorina. Zirconia. Cerium. Manganese, turning brown. Zinc, soluble in excess. Cadmium, soluble in excess. Iron, protosalts, turns brown. Lead. Tin, the protoxide insoluble, the peroxide soluble, in excess. Bismuth. Mercury, persalts. Antimony.

YELLOW PRECIPITATE:—Copper, protosalts; with excess, a colourless solution. Uranium, peroxide. Platinum, peroxide. Gold.

GREY PRECIPITATE:—Mercury, protosalts, from very acid solutions.

GREENISH-BLUE PRECIPITATE:—Copper, deutoxide; with excess, a blue solution.

REDDISH-BLUE PRECIPITATE:—Cobalt, a brown solution, with an excess.

APPLE-GREEN PRECIPITATE:—Nickel; with excess, a violet solution.

GREEN PRECIPITATE:—Chromium. Uranium, protoxide. Platinum, protoxide.

BROWN PRECIPITATE:—Manganese, deutosalts. Iron, persalts. Silver, soluble in excess.

BLACK PRECIPITATE:—Mercury, protosalts.

NO PRECIPITATE:—Potash. Soda. Lithia. Ammonia. Barytes. Strontian. Lime. Silver, if in a very acid solution. Magnesia, the same.

4. CARBON.

Symbol, C; *Equivalent*, 12; *Not volatile*; *Atomic Measure, when isolated, unknown*; *Atomic Measure, when acting as an Acid Radical in Salts*, o; *Condensing Action on other Radicals*, o.

Occurrence.—See page 9.

Properties.—The different kinds of carbon, or charcoal, have a very different appearance, and also extremely different properties. The purest variety of carbon is the diamond. This is crystalline and colourless, possessed of remarkable brilliancy, and a hardness exceeding that of all other bodies. Occasionally it is found coloured. A blue diamond, in the collection of Mr. Hope, which is about an inch long and half an inch wide, has been valued at £30,000. A model of it may be seen in the Museum of Mines, Jermyn-street. This is a curious example of the fanciful value that may be ascribed to a thing which is of no use. The other varieties of carbon, which often contain very small quantities of foreign substances, are all black, opaque, and in general dull. Sometimes they are pulverulent, sometimes solid and porous, sometimes glossy and crystalline, as in the instance of plumbago. The principal kinds are wood charcoal and coal. In the presence of air, and at a red heat, most sorts of carbon burn into carbonic acid gas or carbonic oxide gas, and so fly away, leaving behind only a small residue of ashes. Diamond and plumbago require, however, a very high temperature for their combustion. All the varieties of carbon are insoluble in water, infusible by heat, and incapable of being volatilised. This invariable solidity, or fixedness, is a remarkable quality of this element. With oxygen, hydrogen, and nitrogen, it forms gases, but, *per se*, it is never liquid nor gaseous. When common charcoal is boiled in nitric acid, it disengages carbonic acid gas; when it is mixed with nitre and heated, it explodes.

Carbon has a strong tendency to combine with oxygen, especially at a red heat, and is on that account often employed to separate oxygen from other substances. It appears to have no action upon atmospheric air at mean temperatures, whether wet or dry. Yet when it is in fine dry powder it has a powerful action upon substances that are in a state of putrescence, which it seems to *burn*, or convert into carbonic acid, and thus render innocuous. So rapid is this destruction, that powdered charcoal, placed between folds of cloth, can be used as a respirator to protect the mouth and nostrils of persons who may have occasion to expose themselves in an infected atmosphere. Powdered wood charcoal, placed in trays in the dissecting-rooms of anatomists, in the wards of hospitals, and in other places where putrescent substances spoil the

air, are found to destroy the putrescent matter, and render the atmosphere wholesome. The injurious volatile matter is rapidly absorbed and burnt. For the same reason, charcoal is an important ingredient for filters that are to be used in filtering water, to deprive it of ingredients injurious to the health of human beings. The most effective kind of carbon for use in destroying odours or putrescent effluviæ is that which is called bone-black, and which consists of a mixture of charcoal and phosphate of lime. See page 325.

Carbon combines with oxygen, and produces the two gases that are called carbonic acid and carbonic oxide. It also combines with nitrogen, chlorine, and many metals; but it is above all distinguished by its property of combining with hydrogen under the influence of organic life, and producing the compounds which are called *Hydro-carbons*, *Compound Radicals*, or *Organic Radicals*—compounds of the utmost importance in vegetable and animal chemistry, and of which we shall take particular notice in a subsequent section.

The specific gravity of carbon varies greatly according to its condition. In the state of diamond, its specific gravity is 3.5; in the state of graphite it is 2.2; in the state of wood charcoal it is about 1.6; and some varieties of it, such as lamp-black, are still lighter, according to the mode of preparation.

EXPERIMENTS ILLUSTRATING THE PROPERTIES OF CARBON.

1.) In flame a slip of wood, a match, and plunge it, as the combustion proceeds, into a glass test-tube. The wood will be converted into a black porous mass of charcoal, having the same form as the original wood. That this charcoal is impure, may be proved by burning it completely in the open air, when a small quantity of white ash will remain. This consists of silica, potash, lime, and other mineral substances which exist in all organic bodies. See page 14, and page 62, paragraph 11.

2.) If you expose sugar, starch, cotton, linen cloth, or wood, to a strong heat over a spirit-lamp, in a glass tube, these substances will be decomposed, and you will obtain charcoal—the oxygen and hydrogen of the compounds, and part of the carbon, escaping in the state of water and other volatile compounds. See page 61, C, and the subsequent section on the Nature of Combustion.

The purest kind of carbon that can be prepared by art is obtained by calcining sugar that has



been purified by repeated crystallisation. Even that, however, contains a little potash, and about a half per cent. of oxygen and hydrogen. Rice contains very little earthy matter, and gives almost pure charcoal when calcined in close vessels.

3.) Wash a piece of pure white linen cloth till all soluble substances are removed from it. Then burn it in the open air until nothing remains but a white ash. Put this into water, when a portion will dissolve, and the solution will give a blue colour to purple litmus paper, showing the presence of a fixed alkali derived from the linen. The insoluble portion of ash consists of salts of earths and metals.

4.) Calcine a fragment of flesh (lean beef or mutton) in a small porcelain crucible, closed with its cover. The product is animal charcoal.

5.) Calcine, in the same manner, a fragment of bone. The product is bone-black or ivory-black, which, besides charcoal, contains phosphate of lime. When bone-black is calcined in the open air, the charcoal burns away, and the product is a white powder, called bone-ash. See page 325. Animal charcoal may be partially separated from earthy matter by digestion in muriatic acid and subsequent washing with water.

6.) *Method of collecting the Ashes left by Burnt Vegetable Substances.*—In chemical analysis, it is frequently necessary to collect every particle of ash left by a burnt vegetable body, such as a paper filter, in order that it may be weighed. The following apparatus is useful in some cases of this description. It consists of a Bunsen's gas-burner, fig. 330, upon the top of which is placed a star-shaped support, and upon that a porcelain tray, fig. 329. The gas flame rises in the middle of the tray. The vegetable substance is held over it by the points of a small pair of platinum tongs, and is burnt at the flame, and the ashes are collected on the porcelain tray, from which they can be wiped by a small feather into a watch-glass to be weighed.



329.



330.

7.) When a small quantity of a mixture of earthy matters and charcoal is to have the latter separated from it by combustion in the open air, the apparatus which is represented by fig. 322 may be used. This consists of a small iron spoon, having a bowl of about $\frac{3}{4}$ inch diameter, and which is held by means of steel tongs. The process is not of very accurate performance, as part of the ash is liable to be blown away.

8.) In cases where the matter to be acted upon is very difficult of combustion, the apparatus shown by fig. 331 can be employed. This

consists of three pieces, a crucible, a perforated cover, and a bent tube, all formed of Berlin porcelain. The matter to be acted upon is ignited in the crucible, and while it is undergoing ignition a current of oxygen gas is very gently forced upon it from a gasometer, through the porcelain tube. Oxygen gas, applied at a red heat, acts powerfully upon all organic matters, and drives off the carbon in the form of carbonic acid. The pressure of the gas must be nicely regulated, in order not to blow the ash out of the crucible.

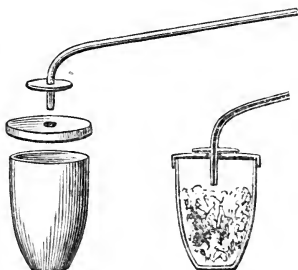

331.

9.) The flame of a candle or argand-lamp is rendered brilliant by the presence of innumerable particles of carbon in the act of undergoing combustion at a white heat. If a cold incombustible body is held in the flame, the consequent abatement of temperature is attended by a deposition of carbon in fine powder (soot), or, if the central air-way of the lamp is stopped, the carbon goes off in smoke for want of oxygen to burn it.

10.) The flames of carburetted hydrogen gas and of coal gas deposit soot for the same reason.

11.) A bit of resin, heated on a fragment of glass over a lamp, burns under production of much smoke, which is finely-divided carbon or lamp-black. The annexed figure represents one of the methods of preparing lamp-black in quantities for use in the arts, as for the preparation of printing ink, &c. The combustible organic matter, resin or tar, is heated in an iron pot, to which only a limited quantity of air is permitted to have access, by which arrangement it is made to burn so as to produce but little flame and a vast quantity of smoke. This passes with the current of air, from the pot, *a*, into a small house, *b*, the walls of which are lined with flannel, and which has a moveable cover or canopy, *d*, made of canvas. The superfluous air, the carbonic acid, and other gaseous products of the combustion escape from the house through the canopy; but the smoke is deposited either on the floor, the flannel lining of the walls, or in the canopy, and is collected from time to time by agitating the canopy, after which the lamp-black is removed from the floor.

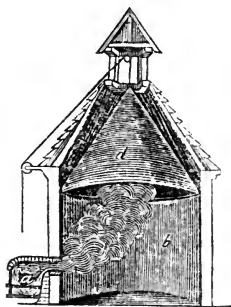

332.

12.) Charcoal has the property of removing colour from vegetable

substances, and also of destroying odours. Thus, when it is coarsely powdered and shaken in a bottle with red wine, and the mixture filtered, the wine becomes colourless, and loses its odour. If charcoal is shaken with water that has the odour of putrid vegetables, the bad odour is destroyed. This experiment may be tried with any kind of dirty water. Treated in the same way, beer is deprived of its bitterness. Charcoal is, for these reasons, employed in the refining of sugar, in the distillation of brandy, in the filtration of water, and in other useful arts.

13.) Newly-burnt vegetable charcoal, especially that made from hard woods, has the property of absorbing a very large quantity of some kinds of gas. A cubic inch of boxwood charcoal absorbs of ammonia gas 90 cubic inches, of muriatic acid gas 85 cubic inches, of hydrogen gas $1\frac{3}{4}$ cubic inches, and different quantities of other gases. Cork charcoal and other light kinds absorb scarcely any quantity of gas. Owing to its power of absorbing gases, large masses of newly-burnt powdered charcoal are liable to undergo spontaneous combustion when exposed to damp air.

14.) The combustion of charcoal in oxygen gas has been already described. See page 182.

15.) *Brilliant Inflammation of Charcoal.*—Support a short and wide hard glass test-tube in a vertical position by a tin crook, as shown by fig. 147, in page 183. Put into the tube about half a fluid ounce of strong fuming nitric acid. If the acid is not of the strongest kind, it may be warmed gently. By means of a pair of crucible tongs, take hold of a stick of charcoal pastile, such as are used to cut glass, or formed of a mixture made of charcoal powder, carbonate of soda, and rice paste, or of any other carbonaceous mixture that will burn continuously

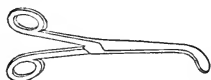

333.

without flame. The stick should be a few inches long and a quarter of an inch thick. The end of it is to be set on fire, and is then to be dipped into the tube containing the fuming nitric acid. As soon as the glimmering end of the charcoal comes into the acid vapour, the combustion is greatly promoted; but when the point is dipped into the liquid acid, the combustion becomes extremely brilliant. The experiment is not hazardous if carefully performed.

16.) *Indelible Ink for Writing on Paper.*—Common black writing ink, which consists in the main of gallate of iron, can be obliterated by oxalic acid, chlorine, or any substance capable of decomposing the gallate of iron. *Indelible* inks must have carbon for a basis, because no liquor can dissolve carbon without destroying the paper which bears the writing. It is, however, difficult to *fix* carbon upon paper, so that it shall not rub off mechanically. The following mixture effects the purpose to a certain extent. Mix—

China ink, 2 parts.

Water, 30 parts.

Strong solution of caustic potash, $1\frac{1}{4}$ part.

Strong solution of caustic soda, $\frac{1}{2}$ part.

This mixture is hygroscopic, and therefore continuously fastens the black colouring matter to the paper.

Another mixture that has been recommended is carbon in the state of china ink, lamp-black, or some other finely-divided form, ground up with gluten, and diluted to a due consistence for writing.

17.) *Ink for Printing on Linen with Types.*—Dissolve 1 part of asphaltum in 4 parts of oil of turpentine; add fine lamp-black in sufficient quantity to render the ink stiff enough to print with types, or with a brass stamp.

18.) *Indelible Inks, useful for Writing Labels for Bottles containing Acids, &c.*—1. Take oil of lavender, 200 grains; gum copal, in powder, 25 grains; and lamp-black, 3 grains. Dissolve the copal in the oil of lavender, in a small flask or phial, by the aid of a gentle heat; and then mix the lamp-black with the solution by trituration in a porcelain mortar. After a repose of some hours, the ink, before use, requires to be shaken, or must be stirred with an iron wire. If it be found too thick, it may be diluted with a little oil of lavender or of turpentine.—2. A solution may be made, in like manner, of 120 grains of oil of lavender, 17 grains of copal, and 60 grains of vermilion.—3. Boil 1 ounce of finely-rasped Brazil wood and half an ounce of alum in 12 ounces of water, till the liquid is reduced to 8 ounces; then decant the clear part, and add to it an ounce of calcined manganese mixed with half an ounce of gum arabic.—4. Amber varnish, ground with lamp-black, makes a black ink; or ground with vermilion, it makes a red ink, both of good colour, but slow to dry.

19.) *Tooth-Powder.*—Finely-powdered charcoal (calcined bread, rice, or sugar) forms an excellent tooth-powder; it cleanses the mouth both mechanically and chemically; but as it is dusty, and not easily miscible with water when alone, it may on this account be mixed with an equal weight of prepared chalk, and, if agreeable, be scented with a few drops of oil of cloves.

20.) *Black Chalks for Drawing.*—Saw fine-grained charcoal into the size of crayons. Put them into a pipkin containing melted bees'-wax, and allow them to remain near a slow fire for half an hour or more, according to the thickness of the crayons. If the crayons are required to be hard, you must mix a little rosin with the wax. If you want them soft, you must add butter instead of rosin.

COMPOUNDS OF CARBON AND OXYGEN.

CARBONIC ACID.—*Synonyme, Carbete*: *Formula*, CO^2 ; *Equivalent*, 44; *Atomic Measure*, 2 volumes; *Specific Gravity of Gas*, 22; *Atomic Measure in Volatile Salts*, 0.

Carbonic acid is a gas which is colourless, slightly odorous, has a sharp acid taste, is incombustible, and does not support the combustion of burning bodies. It precipitates lime-water, and reddens wet litmus paper feebly, but the redness disappears in the air. It occasions death when breathed in a pure state; but its solution in water, beer, or wine is wholesome and refreshing, carbonic acid being the principle which causes the effervescence of soda water, stout, champaign, &c. It is heavier than atmospheric air in the proportion of 22 to 14.47. The gas is slightly soluble in water. By cold and the pressure of 40 atmospheres it is reduced to the state of a thin colourless liquid, and by more intense cold to the solid state.

The condensation of the gas to the liquid state is effected by means of a strong iron pump or syringe. The apparatus is expensive, and its use dangerous.

Liquified Carbonic Acid has the remarkable property of being four times as expansible as atmospheric air. Its specific gravity at -4° F. is 0.90; at 32° F. it is 0.83; at 86° F. it is 0.60. A current of it produces an intense degree of cold. When it flows from a small opening a white vapour appears, which can be collected in the form of white snowy flocks by a flask. These flocks are *solid carbonic acid*, which can be exposed for some time to cold air without changing to gas. The solid carbonic acid can be exposed to the air of the atmosphere, in which it soon volatilises. If the solid acid is mixed with ether, it produces so intense a degree of cold as to freeze mercury in large pieces.

Carbonic acid gas is extricated in most common cases of effervescence, as when vinegar, or any other acid, is poured upon chalk, marble, or alkaline carbonates. It is produced by fermentation, by most instances of combustion, by the respiration of animals, and by the putrefactive decomposition of vegetable and animal remains. It is found in mines, mineral waters, volcanos, and various other situations, giving rise to many interesting phenomena.

This gas, being much heavier than common air, always keeps its place over the surface of a fermenting liquor, till it rises as high as the edge of the tub or vat which contains it, and then it flows over and descends to the floor. To prove this, hold a lighted candle a few inches above the top of the vat, nothing will take place; next, hold the candle just over the liquor within, and below the top of the vat, upon which the light will be extinguished. The heaviness of this gas is the reason, too, why, when the vat is emptied of the liquor, the gas for some time occupies the bottom of it, so that it is unsafe for the workmen

to go down to clean it. This is well known to labourers in breweries, who never descend into the vats before they have tried the purity of the air in them by lowering a candle. If the candle is not extinguished, they know that they may descend with safety; for that is a certain sign that the carbonic acid gas has escaped.

After wine or beer is bottled, the fermentation still goes on, though in a much slower degree, and in wine a deposition of tartar takes place. The carbonic acid gas now extracted, being unable to escape, is absorbed by the liquor, and gives to it that briskness and pleasant sharpness which is so far preferable to the flat insipid taste which all wines have when first made.

In bottling every kind of wine, cider, beer, or other fermented liquors, great care should be paid to the corking. The gas, as it is formed, exerts great force to escape, and if the cork does not fit very accurately, will be sure to find its way out. The liquor will then never acquire the briskness and sharpness that it ought to do; for as the briskness of all such liquors depends upon the presence of carbonic acid gas, they will always prove flat and insipid when the gas is allowed to escape. — It is much better to lay bottled liquor sidelong than upright, for then the gas must not only pass through the liquor before it can escape, but the cork is kept wet and swelled, and is much less liable to decay.

Carbonic acid gas is produced in abundance when charcoal is burned; and it is owing to their not being aware of this production of life-destroying air that many persons have been killed by going to sleep in rooms where charcoal fires were alight. What renders this practice more dangerous is, that charcoal fires sometimes give off not only carbonic acid gas, but carbonic oxide gas, which is still more poisonous than carbonic acid gas.

If the carbonic acid gas, which is produced so extensively under these various circumstances, and which mingles with the atmosphere, was not continually absorbed and destroyed by plants, the air would speedily become unfit for respiration, the world would cease to be habitable, and men and animals would all die.

Preparation of Carbonic Acid Gas.

1.) Put a lump of chalk into a test-glass half full of water, and add a little hydrochloric acid. A strong effervescence will take place, in consequence of a rapid disengagement of carbonic acid gas. If you pour hydrochloric acid over a considerable quantity of powdered chalk, covered with water, the resulting effervescence will be very great. In trying this experiment, put the glass containing the chalk in the middle of a large dish. See page 56.



The theory of the production of carbonic acid gas, when carbonates are decomposed by acids, is explained in the section

which treats of the Constitution of the Carbonates. See the paragraph on the *Solution of Chalk in Hydrochloric Acid*.

2.) Mix 108 grains of red oxide of mercury with 4 grains of finely-powdered charcoal, and beat the mixture in an apparatus such as is represented by fig. 311. Gas will be liberated, which may be collected either over mercury or water. It is carbonic acid gas :



Two equivalents of mercuric oxide and one equivalent of carbon yield four equivalents of the mercuric radical Hgc and one of carbonic acid CO^2 . The 4 grains of carbon prescribed in the above instructions contain 1 grain in excess of the quantity demanded by the equation, and this excess remains uncombined in the retort tube. The mercury condenses in the metallic state on the cold part of the tube.

3.) Carbonic acid gas is most conveniently prepared from chalk or marble mixed with diluted hydrochloric acid in a gas bottle. No heat is required. If a rapid current of gas is desired, the chalk may be powdered, and the acid be of the strength of 30° . If a slow current of gas is wanted, the limestone should be of a hard kind and in lumps, and the strength of the hydrochloric acid should not exceed 20° . White marble gives pure gas. When a small quantity of gas is required, the

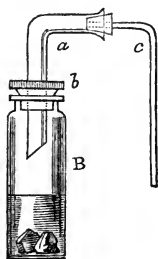

335.

bottle depicted in fig. 335 may be used. For larger quantities, it is best to use the bottle shown by fig. 168, at page 193, in which case the acid is to be added gradually. The other gas bottles, described at pages 192 to 194, also serve the purpose, but are not quite so handy.—The gas may be passed through water to purify it. It may be collected over water; for though a quantity dissolves, yet the gas is so cheap and easy to prepare, that a little loss is of no moment. It may be dried by chloride of calcium or oil of vitriol. See page 198. It can also be collected over mercury, or, like sulphurous acid and chlorine gas, by the method of displacement.

Instead of hydrochloric acid, you may use nitric acid; but it is more expensive, and offers no special advantage. You cannot conveniently use sulphuric acid, because the residual product is in that case insoluble, and therefore inconvenient. Chalk, and all other forms of carbonate of lime, when dissolved in these three acids, yields the following products:—

With nitric acid . . .	CaNO^3	= Nitrate of lime.
With hydrochloric acid	CaCl	= Chloride of calcium.
With sulphuric acid . .	CaSO^2	= Sulphate of lime.

The two first are very soluble in water. The latter requires 400 times its weight of water for solution.

4.) Carbonic acid is produced whenever charcoal is burnt in oxygen gas, or whenever there is an excess of oxygen produced by any decomposition that occurs at the same time as the combustion of the charcoal. See pages 59 and 182.

5.) If a piece of well-burnt charcoal be introduced into a glass vessel, two-thirds filled with oxygen gas, over mercury, and the mercury be brought to the same level on the inside and on the outside of the jar, and the charcoal be inflamed by a burning glass, there will be at first an expansion; but after the experiment is over, it will be found that the volume of the gas has not perceptibly altered; and if the charcoal has been in sufficient quantity, the whole of the oxygen gas will be found converted into carbonic acid gas. Now the densities of oxygen gas and carbonic acid gas, in whatever way they may be formed, are always the same, and are to each other as 16 is to 22. It is evident, then, that carbonic acid must always contain the same weight of oxygen and charcoal. See page 153.

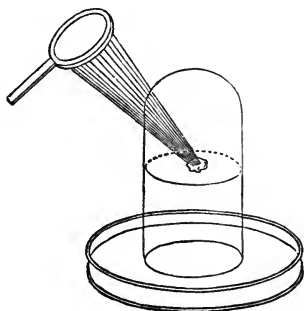

336.

6.) If a diamond is thus burnt in oxygen gas, it also produces carbonic acid gas. The experiment has frequently been made to prove this fact; but it is too costly for repetition as a class experiment.

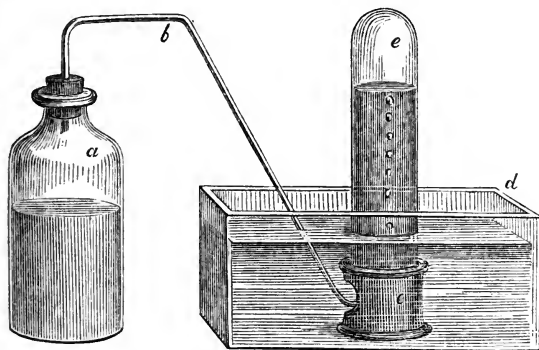

337.

7.) *Carbonic Acid Gas is produced during Fermentation.*—Arrange an apparatus for the preparation and collection of gas, as shown by fig. 337. Into the gas bottle, *a*, put a mixture of one part of honey or

sugar, six parts of water, and a little yeast. Expose the whole apparatus to a heat of 70° or 80° Fahr. After some time fermentation takes place, and carbonic acid gas is liberated. The honey acts quicker than the sugar. If the fermentation is allowed sufficient time, all the sugar will be decomposed, and alcohol will remain in the liquid. The carbonic acid gas will pass by the gas-delivery tube, *b*, into the jar, *e*, which is supported by a bee-hive shelf, *c*, placed in a pneumatic trough, *d*, which is represented in this figure as made of a single piece of glass.

The decomposition of the sugar may be represented as follows:—

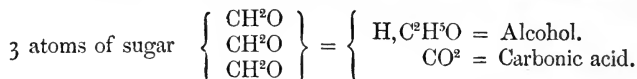

This is the usual process by which alcohol, or spirits of wine, is prepared in the large way from sugar or malt. The spirit is subsequently separated from the water by distillation, the alcohol rising into vapour at a lower degree of heat than that demanded for the conversion of water into steam.

EXPERIMENTS WITH CARBONIC ACID GAS.

1. *To show that Carbonic Acid Gas extinguishes Flame and destroys Animal Life.*—Fill a small glass cylinder, or a bottle, with carbonic acid gas, and plunge a lighted candle into it; the flame will be extinguished.



338.

A person who is quite a stranger to the properties of this kind of gas will be agreeably amused by extinguishing lighted candles, or blazing chips of wood, on its surface. As the smoke readily mixes with the gas, and little or none of it escapes into the atmosphere, the smoke floats, in a very curious manner, on the surface of the gas, forming a smooth well-defined plain, which, if the vessel be agitated, is thrown into the form of waves. Insects, which it is desirable to preserve in their true form and brilliancy of colours, for cabinets, may be killed by immersion in carbonic acid gas.

2. If inflamed sulphur is immersed in a jar of carbonic acid gas it is extinguished.

3. *Illustration of the Characteristic Powers of Oxygen Gas, Carbonic Acid Gas, and Atmospheric Air, with respect to Combustion.*—Set three jars of equal size, fig. 339, mouths upwards, on a table. The first must contain common air; the second, carbonic acid gas; and the third, oxygen gas. Take a lighted candle with a pretty large wick, and lower it, by means of a wire, into the *first* jar—the flame will have its usual brightness. Lower it next into the *second* jar—the flame will be extinguished. Lower it now, while the wick continues red, into the *third* jar—it will be relighted, and will burn for some time with a dazzling

splendour. To ordinary spectators, this experiment will be the subject of much wonder. The whole of the jars will, by them, be deemed *empty*, and the different effects resulting from plunging the same candle into seemingly similar vessels, will be quite incomprehensible.

4. Hold a slip of moistened blue litmus paper in a jar of carbonic acid gas, or dip it into the aqueous solution of the gas. It will turn claret red; but if the paper is afterwards heated or exposed to the air, the acid volatilises, and the blue colour is restored.

5. *Pleasing mode of showing the great Weight of Carbonic Acid Gas.*
—Place a lighted candle in the bottom of a jar which has its open part

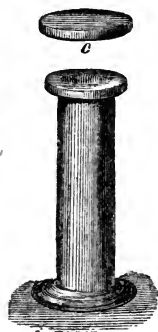

339.



340.

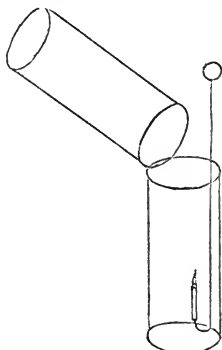

341.

uppermost, the jar being filled with atmospheric air; take then a jar filled with carbonic acid gas, and invert it over the jar in which the candle is placed, fig. 341. The effect is very striking; the invisible fluid descends like water, and extinguishes the flame. To spectators who have no idea of substance without sensible matter, this experiment has the appearance of *magic*.

6. A burning candle may be lowered into a jar containing carbonic acid gas, until the top of the wick is about half an inch under the surface of the gas, in which position the flame will remain visible for a few seconds, though *altogether detached from the candle*. The exposition of this phenomenon is, that the wick remains hot enough to cause the tallow still to evaporate, and the vapour kindles at the surface of the carbonic acid gas.

7. It affords an amusing spectacle to let a large soap-bubble, filled with common air, fall into a tray or wide glass containing carbonic acid gas. The bubble rebounds from it like a foot-ball, and appears to rest on nothing.

8. Suspend a large glass globe, fig. 342, to one end of a balance, and counterpoise it. Then decant a large jarful of carbonic acid gas

into it, upon which it will become so heavy as to overbalance the counterpoise.—The method of determining the weight of a gas with accuracy is described at page 277.

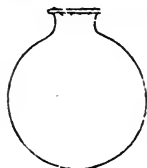

342.

9. *To show that the Atmosphere contains Carbonic Acid.*—Expose to the air, in a flat open vessel, a quantity of transparent lime-water; a white crust will soon form on its surface, which, on being broken, falls to the bottom of the vessel, and is succeeded by another—this precipitate, upon being examined, proves to be carbonate of lime—therefore, carbonic acid is attracted from the atmosphere by the lime in solution.

10. The apparatus depicted in fig. 343 is to be set up, but without the parts marked *a*, *b*, *c*. A little lime-water is to be put into the

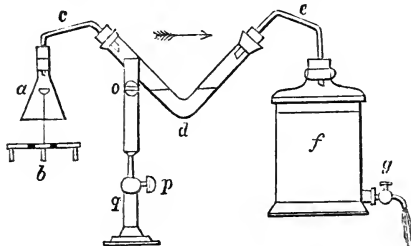

343.

V-tube at *d*, and atmospheric air is to be drawn through it by allowing water to run from the bottle *f* by the stopcock *g*. At the end of an hour a quantity of carbonate of lime will be formed, and will render the inside of the V-tube obscure. It may be washed off by a little diluted hydrochloric acid.

11. *Proof that Carbonic Acid Gas is given off from a Charcoal Fire, the Flame of a Candle, or the Flame of a Spirit-lamp.*—Set up the apparatus described above, fig. 343. Put lime-water into the tube, *d*. Instead of the stand, *b*, put the flame of a spirit-lamp or of a candle into the funnel, *a*, or place a small lighted charcoal furnace below the funnel. Then let water run from the stopcock, *g*. The lime-water in the V-tube will immediately begin to give a white precipitate of carbonate of lime. Another proof of the existence of charcoal in alcohol is given in the article on the preparation of olefiant gas. In that experiment, the charcoal is separated in the form of a black powder.

The nature and products of combustion are explained more fully in another section.

12. *To show that Carbonic Acid is contained in Air respired from the Lungs.*—1. Put into a test-glass a little water, tinged blue by tincture of cabbage; then blow into this water, through a glass tube, air from the lungs—the blue colour will soon be changed to red. This proves that the air blown from the lungs contains an acid. Now, query, what acid is it? Let us see.—2. Warm the product of process 1, the blue colour will be restored. Hence the acid is volatile, and must be either carbonic acid or sulphuretted hydrogen. That it is not the latter, may

be known by its want of odour, and the impossibility of its derivation from the breath; that it is the former, may be proved thus,—3. Blow air, in the manner described above, into lime-water. The transparent solution will be shortly rendered opaque by the formation of carbonate of lime.—4. A little hydrochloric acid added to the muddy liquor will render it again transparent, by dissolving the carbonate of lime with effervescence. I have described at page 272 an apparatus by which it is easy to show the great difference in the proportion of carbonic acid gas contained in atmospheric air and in air respired from the lungs.

13. *Presence of Carbonic Acid in Fermented Liquors.*—Put a small quantity of fresh porter or strong ale into a gas-bottle, connect the gas-delivery tube with a V-tube containing lime-water, and apply a gentle heat to the beer. Carbonic acid gas will immediately pass off and form a precipitate in the lime-water.

14. *Production of Carbonates.*—Fill a long tube with carbonic acid gas, and set the open end in a capsule containing a solution of caustic potash or of ammonia. The liquor will absorb the gas rapidly and rise in the tube. After permitting a little of the liquor to rise, you may close the tube with a finger, shake it to mix the solution with the gas, and again open the tube in the alkaline solution, which will then rush into it violently.

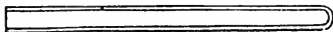

344.

15. *Vacuum produced by Chemical means.*—The last experiment may be performed in a striking manner as follows:—Take a glass tube, 6 feet long and $\frac{3}{4}$ inch in diameter, closed at one end, and pretty strong in the glass. When so long a tube cannot be procured, two shorter tubes may be joined by a brass or tinplate collar, fastened by strong cement. Fill the tube with water that has been boiled, and then cooled in a corked bottle to free it from air. Invert the tube over a pneumatic trough, fix it in a vertical position, and fill it, to within an inch of the end, with pure carbonic acid gas, free from air. Have ready a sound cork, exactly fitted to the tube, and a stick of caustic potash about an inch long. Put the potash into the tube, instantly cork the tube, take it from the trough, and invert it repeatedly, that the stick of potash may pass up and down, and not lie for any time on one part of the tube, which would be broken by the heat produced by the absorption of the carbonic acid. At the end of a few minutes the carbonic acid gas will be entirely absorbed. Now put the mouth of the tube into a basin of coloured water, and take out the cork, which should be provided with a turned milled wooden top or handle, like the cork of the gas-bottle, *b*, fig. 335. The instant the tube is opened, the water will violently rush up to the very top of it.

The apparatus represented by fig. 316 can also be used to show the rapid absorption of carbonic acid gas by a solution of caustic potash.

SATURATION OF LIQUIDS WITH CARBONIC ACID GAS.

PREPARATION OF EFFERVESCING BEVERAGES.

Solution of Carbonic Acid in Water.—1. Pass a current of carbonic acid gas slowly through distilled water until it ceases to be absorbed. See the methods of passing gases into liquids described at pages 179, 262, 330, &c. One measure of water absorbs one measure of carbonic acid gas at common temperature and pressure. By means of a force-pump, it can be made to absorb 2 or 3 measures of gas, in which condition, either with or without a little bicarbonate of soda in solution, it passes under the name of *Soda Water*.—2. Fill a quart bottle with carbonic acid gas, pour into it half a pint of cold distilled water, cork the bottle, and shake it. Invert the bottle, and let it rest in a cold place. Shake it occasionally, and after some time the water will be strongly acidified. The solution of carbonic acid gives a white precipitate with lime-water, and readily gives off carbonic acid gas when gently heated.

SODA-WATER APPARATUS.

As an example of the methods employed to saturate liquids with carbonic acid gas effectively, I will describe two of the best forms of soda-water apparatus, availing myself of the figures, and partly of the descriptions, that are given by Dr. MOHR in his *Pharmaceutischen Technik*.

Figures 345 and 346 represent a soda-water apparatus, formed of



345.

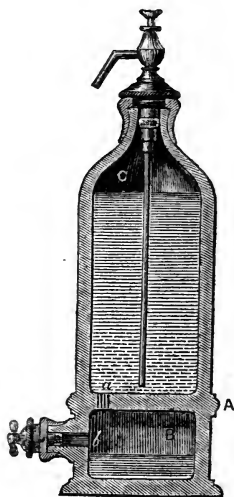

346.

salt-glazed stoneware, but supplied with fittings of block tin. Fig. 345 represents the outside of the apparatus, and fig. 346 a section. The vessel is divided into two compartments, B and C, by the false bottom, A. The lower compartment is of the capacity of a quarter to half a pound of water. The upper compartment varies in size according to the quantity of effervescing liquor intended to be prepared at one operation. The lower space, B, is the carbonic-acid generator. It is filled through the opening, *b*, which is then closed by the stopper represented by fig. 347. This stopper is a solid mass of tin, A, which is secured in the opening, *b*, by means of a bayonet-catch. In the body of the stopper there is a groove, which is filled with a solid ring of vulcanized caoutchouc, G. Above this caoutchouc ring is a ring of tin, B, of the form shown by the figure, which can pass backwards and forwards on the plug, A, but cannot be turned round. This ring serves partly to render the closing of the opening secure, and partly to serve as a block against which the caoutchouc ring, G, can be firmly pressed by a few turns of the female screw, C, which acts on the male screw cut on the plug, A, and so effects the hermetical closing of the mouth of this compartment of the apparatus.

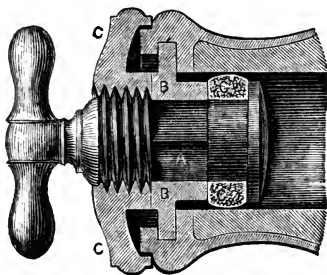

347.

The compartment, C, above the false bottom, A, represented in fig. 346, is to contain the liquor which is to be saturated with the carbonic acid gas that is produced in the compartment, B. The false bottom, A, is pierced at *a* by a number of very small holes, which are represented by the black lines in the figure. Through these holes the gas rises into the liquor contained in the compartment, C. The liquor cannot descend through the holes, partly because they are too capillary, partly because the pressure of the gas in the lower compartment offers too great an obstacle. Hence the liquor contained in C becomes impregnated with the gas, without coming into contact with the materials by the reactions of which the carbonic acid is produced.

The neck of the bottle is closed by a stopper, also made of tin, which is so contrived as not only to afford sufficient pressure against the condensed gas, but to provide the means of decanting the impregnated liquor when required for use. This stopper is represented in its place in figures 345 and 346, and the head of it, very nearly of its full size, is shown in section by fig. 348. The plug A is analogous to the plug A in the stopper shown by fig. 347, and is fastened into the neck of the flask by a similar arrangement, as is evident on a comparison of

the figures. But this stopper differs essentially from the former in being hollow, so as to form, with its accompanying pipes, a syphon for decanting the effervescing beverage.

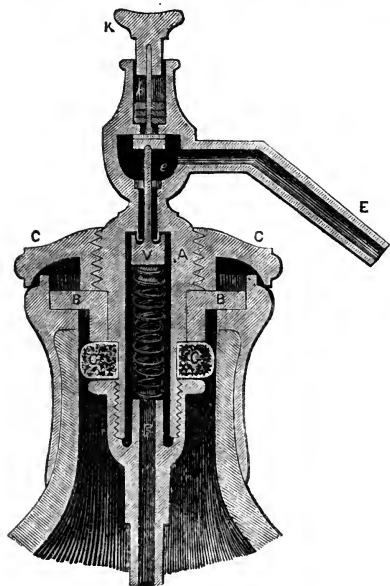

348.

If we suppose the liquor, as represented in fig. 346, to be saturated with gas, and the space C above the liquor to be full of condensed carbonic acid gas, it is easy to understand how, upon the opening of a free communication between the tubes F and E, represented in fig. 348, the pressure of the gas at C will force the liquor out of the vessel through those tubes. This free communication is effected by simple pressure upon the knob K. That pressure forces down the valve V, and clears the way from the tube F, and the space around the spiral spring, to the space e and the tube E. The liquor cannot pass upwards from the space e, because the rod k passes through an air-tight stuffing-

box, containing several collars of caoutchouc. When the pressure on the external knob K is removed, the spiral spring forces up the valve V, and prevents the further escape of the liquor.

Method of using the Apparatus.—Open the upper stopper, and fill the compartment C with pure water, mineral water, wine, lemonade, or whatever liquor you wish to render effervescent. From the full bottle pour out as much liquor as is necessary for the solution of the salts which are to produce the requisite quantity of gas. This liquor, if water, or a corresponding bulk of water, is afterwards to be put into the compartment B. The quantity of this water depends upon the bulk of the apparatus to be used. After decanting that portion of liquor, close the upper neck of the apparatus securely with the stopper. Next incline the flask, and pour into the lower compartment, through the opening b, the water abstracted from the upper compartment, and add to it bicarbonate of soda and tartaric acid in small crystals (not in powder) in the proportions of 4 parts of the alkali to 3 parts of the acid by weight. The absolute quantity of materials is necessarily regulated

by the bulk of the apparatus. The lower neck of the apparatus is to be immediately closed by its stopper, and the apparatus is to be set aside in a cool place for some hours. The reaction takes place between the bicarbonate of soda and the tartaric acid in proportion as the substances dissolve, for which reason it is recommended to use them in crystals and not in powder, in order that the action may not be too stormy. The reaction is shown in the following equation:—

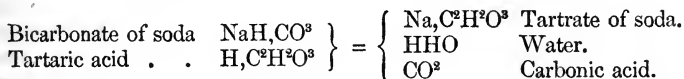

To facilitate the absorption of the gas by the liquor, the apparatus may be occasionally shaken. The gas, which ultimately remains unabsorbed, rises to the space C, fig. 346, and effects a pressure which as already described is finally used to expel the liquor from the apparatus.

To prepare an effervescing beverage that shall not lose its carbonic acid by a rapid action as soon as the liquor is released, the apparatus ought, as soon as it is charged, to be placed in a cold place, if possible in ice, and allowed to remain there for 24 hours.

Precaution.—Before the apparatus is charged with salts, care must be taken to ascertain that the small openings, *a*, in the false bottom between the two compartments of the apparatus, fig. 346, are *clear*. If the apparatus has been out of use, and these holes have become stopped by dust or crystallised salts, then the generated carbonic acid gas will be unable to escape from the compartment B, and its pressure may cause the apparatus to explode with a degree of violence that may expose the operator to great injury. To prevent this accident, the apparatus should be carefully washed out with warm water, and it should be ascertained that, when both mouths of the apparatus are open, and water is put into the upper compartment, it trickles thence through the small holes into the lower compartment. It is further proper, soon after charging the apparatus, and after the first strong disengagement of gas has taken place, to loosen the screw C, fig. 348, and permit the enclosed atmospheric air to escape. The inside pressure is thereby diminished, and the absorption of the carbonic acid is promoted.

Glass Apparatus for the preparation of Effervescing Beverages.—Fig. 349 represents a form of soda-water apparatus, which is now very well made of glass, with solid tin fittings. The entire apparatus is about six times the size of this figure. Only the stopcock and double neck are made of tin; the rest of the apparatus is of glass, the two globes being covered with a network of cane, to prevent the scattering of fragments of glass in the event of the occurrence of an explosion. The two vessels can be separated at the joint immediately below the stopcock. The neck attached to the upper globe contains a solid tin plug, not visible in the figure, in which plug six or eight very fine holes

are bored, to admit of the passage of the gas from below upwards. To this upper neck the stopcock is attached, through which the liquor is to be allowed to escape.

The charging of this apparatus is effected thus:—The upper globe is unscrewed and removed from the foot, and is inverted and filled to within a glassful with water or other liquor that is to be saturated with gas: the plug is then fixed in it. Into the under ball we have now to put the ingredients that are to produce the carbonic acid. For a large-size apparatus, 1 ounce of tartaric acid and $1\frac{1}{4}$ ounce of bicarbonate of soda. The large globe is then screwed firmly upon the small globe, and the apparatus is placed on its side until the small globe is about three-fourths filled with water that has passed into it from the large globe. The apparatus is then placed upright, and put aside in a cold place till the following day.

The stopcock by which the effervescing liquor is passed out of the apparatus is represented in full size by fig. 350. The neck, *a*, is attached to the neck of the globe, as represented in fig. 349. The pipe, *c*, is that by which the liquor escapes through the spaces, *a* and *m*. The efflux of the liquor is stopped when required by the pressure of the plug, *n*, against the end of the perforation, *m*. This is managed by means of the thumbscrew, *r*, which, by the action of the screw,

q, forces the plug, *n*, backwards and forwards. The screw, *q*, works in a collar, which is secured to the pipe, *b*, by the screw, *p*.

This glass apparatus has over the stone kind, fig. 345, the advantage of transparency, which enables you to watch the operation, and to see at any time whether you have a supply of liquor or only an empty bottle. When the glass has been well annealed, it stands the requisite internal pressure satisfactorily.

Mohr's Carbonic Acid Regulator, used in the preparation of Bicarbonate of Soda.—Dr. Mohr recommends the following apparatus for producing a regulated current of carbonic acid gas, to be used without loss for the conversion of neutral carbonate of soda into bicarbonate of



349.

soda. The gas-generator is formed on the principle of the hydrogen lamp, which I have described at page 203. To this are attached a

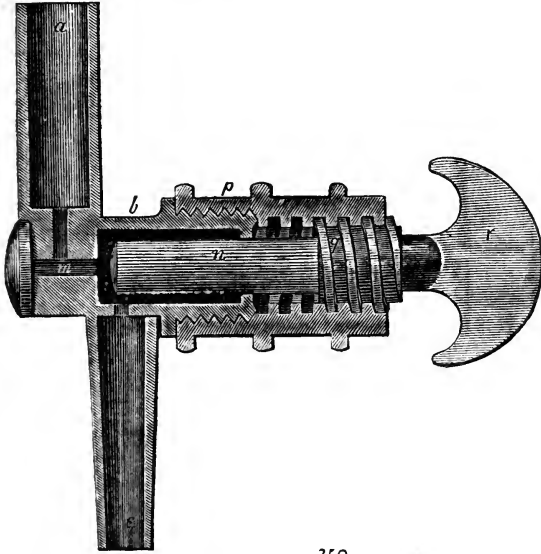

350.

washing-bottle and a vessel to contain the carbonate of soda, upon which the carbonic acid is to act. The whole apparatus is represented in fig. 351. Letter A is a salt-glazed stoneware jar. C is a green-glass

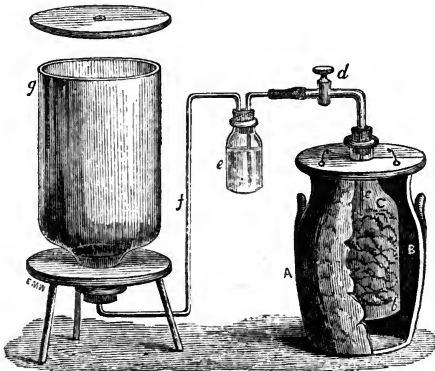

351.

bottle, the bottom of which has been cut off, or, instead of which, a deflagrating jar, fig. 115, may be used. *b* is a disc of brass or lead, connected by a brass rod, *c*, with the brass tube and stopcock, *d*. *e* is a washing-bottle, containing a solution of bicarbonate of soda. This bottle may be provided with a safety-tube. *f*, a glass tube for delivering the purified carbonic acid gas. *g*, a glass vessel to contain the carbonate of soda, at the bottom is a disc of wood, pierced full of holes, upon which the salt is placed. The upper edge of *g* is ground smooth, so that it can be greased and closed air-tight by the round glass plate which is represented above it.

To put this Apparatus into action.—Invert the gas-bottle, C, and fill it to within an inch of the mouth with lumps of chalk or marble, keeping the rod, *c*, in the middle. Put the disc, *b*, on the rod, *c*, and secure it by a brass nut, screwed on the end of the rod. The glass, C, is then to be reversed and put into the jar, A, which is previously to be rather more than half filled with hydrochloric acid, a little diluted with water, and which must be free from arsenic, though it need not be chemically pure. The bottle, C, is kept in its place in the jar, A, by a wooden cover, which is divided through the middle into pieces that are capable of being fixed together by hooks and eyes.

The stopcock, *d*, being closed, the acid in A cannot pass into C among the chalk, but rises in the space B. When *d* is opened, the atmospheric air escapes from C, the acid passes from B into C, and acts upon the chalk, and a current of carbonic acid gas escapes through the stopcock and into the vessel, *g*. If the stopcock is closed, the acid descends from C into B, and the production of gas ceases, as it does also if any obstruction occurs in the vessel, *g*.

Conversion of Carbonate of Soda into Bicarbonate of Soda.—To understand the nature of this process, we must bear in mind the composition of the salts we have to deal with:—

$\text{NaNa,CO}^3 + 10\text{HHO}$ is the composition of crystallised carbonate of soda.

NaNa,CO^3 represents carbonate of soda that has been rendered anhydrous by ignition.

NaH,CO^3 shows the composition of crystallised bicarbonate of soda.

CO^2 is the formula of carbonic acid.

Consequently—

9 atoms of anhydrous carbonate = NaNaCO^3 .

1 atom of crystallised carbonate = $\text{NaNaCO}^3 + 10\text{HHO}$.

10 atoms of carbonic acid = CO^2 .

Are together equal to

20 atoms of bicarbonate = NaH,CO^3 .

These proportions are sufficiently observed, if you take one part of the crystallised carbonate of soda and three parts of the anhydrous car-

bonate of soda by weight. These salts are to be finely pounded and intimately mixed together, and the mixture is to be lightly filled into the glass vessel, *g*, nearly to the top. The vessel is then to be accurately closed by the glass disc, but the small hole is to be left open. The stopcock, *d*, is to be opened, and the atmospheric air is to be expelled from *g* by a strong current of carbonic acid. The small hole in the disc is then to be stopped with wax, some weights are to be placed on the disc, and the process of saturating the carbonate of soda with carbonic acid is allowed to proceed freely. The passage of the gas is visible in the wash-bottle, *e*. At first, the closing of the vessel, *g*, and the pressure thereby produced, stays the current of gas; but the soda salt soon becomes warm, and the gas is then absorbed with rapidity. The process must at this stage be carefully watched, because the absorption of carbonic acid gas by the soda can take place so suddenly and totally, that a vacuum can be produced in the vessel *g*, and the hydrochloric acid be driven from the vessel *A*, through *C* and *e*, into *g*, and so spoil the operation. To prevent this accident, the stopcock, *d*, is brought into play, or else a safety-tube is added to the wash-bottle, *e*.

When the soda salt ceases to absorb carbonic acid, the operation is at an end. The product is then to be pulverised in a mortar, washed with cold water, and dried at a gentle heat.

Mohr's Apparatus for protecting Solutions of Caustic Alkalies against the Carbonic Acid contained in Atmospheric Air.—Solutions of caustic alkalies and caustic earths have a strong tendency to abstract carbonic acid from the atmosphere; but as the presence of carbonic acid impairs their powers as chemical tests, especially when they are to be used in acidimetry (see page 104), it is desirable to preserve the solutions in such a manner as to prevent the access of carbonic acid. Dr. Mohr has recommended the apparatus represented by fig. 352 to be used for this purpose. It consists of an ordinary test-bottle, provided with a decanting syphon and a vertical chloride of calcium tube. A small glass jet is adapted to the bottom of the syphon by means of a caoutchouc tube, across which a pinch-cock is passed. The upper tube is nearly filled with a mixture of crystallised sulphate of soda and quick-lime, or with lumps of soda-lime, a little cotton wool being placed at the orifice of the narrow tube to prevent

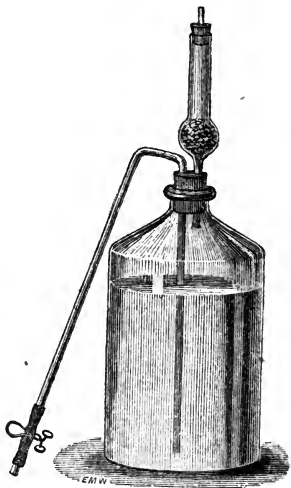

the falling of the powder into the bottle. This mixture allows atmospheric air to pass into the vessel when a portion of liquor is run off by the syphon; but it abstracts the carbonic acid from the air as it passes through the tube. The small quantity of solution which remains in the jet below the pinch-cock must always be run off and rejected when alkali is required from the bottle.

CARBONIC OXIDE.

Synonyme, Carbate. Formula, CO; Equivalent, 28; Atomic Measure, 2 volumes; Specific Gravity of Gas, 14.

Properties.—Carbonic oxide is a gas; colourless and tasteless; of a weak but peculiar odour; burns in the air with a bright blue flame, producing carbonic acid; does not support the combustion of other bodies; is extremely poisonous; it cannot be breathed; animals die in it immediately; it is nearly insoluble in water.

The blue lambent flame that sometimes appears on the surface of a clear red coal fire, or over the ignited lime in an active limekiln, is occasioned by the combustion of carbonic oxide gas. The carbonic acid produced by combustion at the lower part of the fire is converted into oxide of carbon by the action of the large mass of red-hot coal. The oxide of carbon, on coming into contact with fresh oxygen at a red heat, is again converted by combustion into carbonic acid.

When wood is burnt as fuel in stoves, carbonic oxide gas is often disengaged when the combustion is feeble. It is highly dangerous to close the damper of a stove in a close apartment, and thus prevent the escape of the carbonic oxide gas, which in such a case passes into the apartment, and renders its atmosphere poisonous.

Preparation of Carbonic Oxide Gas.

1. Boil crystals of oxalic acid with oil of vitriol in a glass tube. Apply a light to the mouth of the tube, and a *blue flame* will be produced, arising from the combustion of the carbonic oxide gas produced by the decomposition of the oxalic acid.

The gas disengaged in this process is a mixture of carbonic oxide gas and carbonic acid gas. If the mixture is passed through lime-water, or shaken with it in a bottle, the carbonic acid gas is absorbed, and the other gas left pure. Or it may be passed, first through a solution of caustic potash, and then through a V-tube filled with lumps of pumice-stone moistened with potash ley. The gas can be collected over water.

2. Carbonic oxide gas can be prepared in quantity from oxalic acid by means of the apparatus represented by fig. 353, or by any of the forms of apparatus that are suitable for the preparation of gases with the help of heat. In this case the wash-bottle must contain a solution

of caustic potash, requisite for the absorption of the carbonic acid gas. The carbonic oxide gas then passes into the gas-receiver in a pure state.

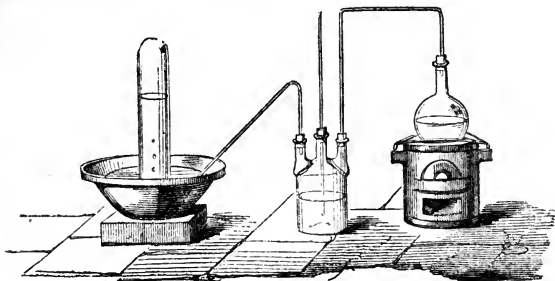

353.

3. Mix in a retort or gas-bottle 1 oz. of oxalate of ammonia in fine powder with $\frac{1}{2}$ oz. of concentrated sulphuric acid; distil with a gentle heat, and collect the gas over a solution of caustic potash or milk of lime.—Binoxalate of potash may also be used in the same manner for preparing carbonic oxide gas. In these experiments the sulphuric acid combines with the base, and liberates the oxalic acid, which falls into carbonic acid and carbonic oxide.

When crystallised oxalic acid is used, the reaction is as follows:—

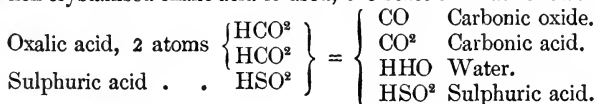

When oxalate of ammonia is used, the reaction is this:—

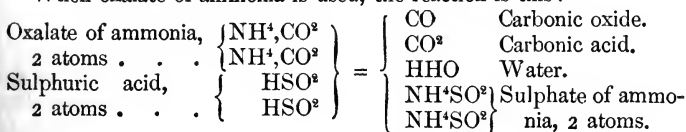

As carbonic oxide, CO, and carbonic acid, CO², have both an atomic measure of two volumes, the gases are given off in equal quantities by measure.

4. Into a gas bottle of the capacity of a decigallon, and the form of fig. 354 or fig. 355, put $\frac{1}{2}$ oz. of yellow prussiate of potash, finely powdered, and 4 or 5 ounces by weight of concentrated sulphuric acid. Close the flask by a cork and gas-leading tube. Apply a gentle heat. A

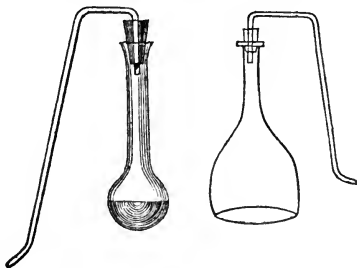

354.

355.

white pasty mass is produced by the first action of the acid upon the salt, but this gradually dissolves and disappears. The above quantity of materials gives 300 cubic inches of carbonic oxide gas perfectly pure, except quite at the end of the operation, when a little sulphurous acid may be noticed.—*Fownes*.

Theory of this Decomposition :

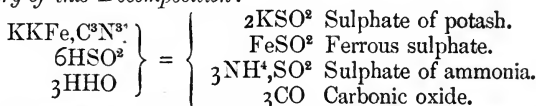

This explanation passes on the supposition that all the nitrogen is converted into ammonium, and all the sulphuric acid neutralised by bases. But the simultaneous production of some sulphurous acid shows that the reaction is not in all cases so simple as this equation represents it. The experiment affords a very curious example of the formation of ammonia by an indirect process. See page 323.

Experiments with Carbonic Oxide Gas.

1. Mix two volumes of carbonic oxide gas with one volume of oxygen gas, and set fire to the mixture, in the manner described at page 206. A loud explosion takes place, accompanied by a yellow flame, and the mixture is converted into carbonic acid gas:—



Two volumes of carbonic oxide and one volume of oxygen, in all three volumes, produce two volumes of carbonic acid.

2. Metallic potassium, heated in carbonic oxide gas over mercury, in an apparatus similar to fig. 356, absorbs the gas, becomes oxidised, and forms a deposit of charcoal:

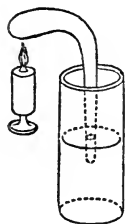

356.

3. Carbonic oxide gas can be burnt at a jet in the same manner as hydrogen gas; but it burns with a blue flame, and when the experiment is made by means of the apparatus described at page 213, no water can be procured from the product of combustion, which proves that no hydrogen is present in this gas.

4. *Conversion of Carbonic Oxide into Carbonic Acid.* Set up the apparatus depicted in fig. 343, but instead of the parts marked *a b c*, substitute the parts marked *a b c* in fig. 209, page 213. Put lime-water into the bend of the V-tube; set the water running at the stopcock *g*, and inflame a jet of carbonic oxide gas at the point of the tube *b*, fig. 209. A precipitate of carbonate of lime will soon be formed in the V-tube of fig. 343. This experiment proves that carbonic oxide gas produces carbonic acid gas when burnt in the air.

5. Carbonic acid gas can be converted into carbonic oxide gas by being passed through a mass of red-hot coke or charcoal. The carbonic

oxide gas which passes off at the upper surface of the charcoal may be set on fire, and will burn with a blue flame. A clear red coal-fire, free from white flame, often exhibits flickering pale-blue flames upon its surface, which are due to the combustion of carbonic oxide gas.

New Mixture for the Gas Blowpipe.—When a mixture of two volumes of carbonic oxide gas and one volume of oxygen gas is allowed to stream from a narrow opening, and is set on fire, the flame does not press backward into the reservoir, but becomes extinguished when the pressure of the gas is feeble. Hence the use of this mixture is free from the danger of explosion; and since it gives as much heat on combustion as an equal volume of the explosive mixture of oxygen with hydrogen, it can be advantageously employed for the gas blowpipe. See page 207.

When the blowpipe is to be used, a small spirit-lamp is to be brought close to the opening whence the gas issues. The gas should not be burnt immediately at the mouth of the stopcock of the gasometer, but at the end of a glass tube having a fine jet, and fixed upon the stopcock. In this case, if the flame goes back, the gas burns quietly in the tube, but the flame does not pass the stopcock. I do not think that the flame could go back even through a metal tube, provided it be long and narrow. With the common pressure of a gasometer, I have melted 19 grains of platinum, supported on magnesite, into a mass. I have also melted quartz. The diameter of the orifice in the jet was $\frac{1}{30}$ inch.—*F. Reich.*

If this mixture of gases escapes into the apartment unburnt, it renders the atmosphere poisonous.

THE CARBONATES AND THE OXALATES.

Owing to the circumstance that, in this work, the combining equivalents of the elements carbon and oxygen are reckoned at double the value which is ascribed to them in most other chemical works, it happens that the formulæ which it is necessary to employ to denote the salts that are called carbonates and oxalates differ from those in common use. It is, therefore, necessary to call the reader's attention in an express manner to the grounds of this difference, in order that he may thoroughly comprehend the relations that exist between the two gaseous oxides of carbon and those two classes of salts, and also that he may clearly comprehend the nature of the difference between *monobasic* salts, such as the oxalates, and *bibasic* salts, such as the carbonates.

In the following formulæ, H = 1, C = 12, O = 16, K = 39.

CO = Carbonic oxide.

CO² = Carbonic acid.

HHO = Water.

KHO = Caustic potash.

KKO = Anhydrous potash.

HCO² = Oxalic acid.

KCO² = Oxalate of potash.

HCO² }
KCO² } = Binoxalate of potash.

KKCO² = Neutral carbonate of potash.

KHCO² = Acid carbonate of potash.

Absolutely, we know not in what manner the two atoms of oxygen in the oxalates and the three atoms of oxygen in the carbonates are divided between the carbon and the basic radicals of the respective salts. If all the oxygen of the oxalic acid is combined with the carbon, then the result is $H + CO^2$, or we are to consider oxalic acid as a compound of carbonic acid with hydrogen. If we suppose the oxygen to be divided equally between the two radicals, then we have the formula $HO + CO$, or the acid is composed of carbonic oxide and oxide of hydrogen. According to the theory generally received, the oxygen contained in oxalic acid is so divided, that three-fourths of it are combined with the carbon and one-fourth of it with the hydrogen; in favour of which theory there is absolutely no evidence, not the smallest inkling of evidence; and when we are desired to adopt that theory as the simple expression of a fact, we are desired to abandon the wholesome practice of scrutinising evidence, without pursuing which no student of chemistry will ever become master of his science.

There is a similar difficulty in the case of the carbonates. We have in each of them, whether neutral or acid, three radicals and three atoms of oxygen. It may be that each radical is combined with one atom of oxygen; or it may be that one atom of carbon takes two atoms of oxygen, and leaves one atom of oxygen for the two atoms of metal. Thus:

either $KO + KO + CO$, or $KKO + COO$.

Of these theories, neither of which is capable of experimental proof or disproof, I prefer the one which assumes that both in the oxalates and the carbonates the carbon exists in that oxidised condition which, when in a separate state, we call carbonic oxide, and denote by the formula CO .

In that case,

The oxalates are	$HO + CO$
The carbonates are	$KO + KO + CO$
The bicarbonates are	$KO + HO + CO$

or, in other words, the oxalates are simple salts, corresponding to the sulphates—

$KO + CO$	oxalate of potash
$KO + SO$	sulphate of potash;

while the carbonates are double salts, or bibasic salts, consisting of oxalates combined with oxides. The bicarbonates, or acid carbonates, differ from the *neutral* carbonates by having one atom of hydrogen in place of one atom of a metal. There is absolutely no other difference, except occasionally in the proportion of water of crystallisation.

It will be found that this theory agrees exactly with the experimental reactions of the various salts.

Reactions of Carbonates.

1. *Ignition of Carbonate of Lime.*—Chalk, when ignited, produces quicklime and carbonic acid gas :

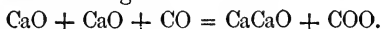

2. *Solution of Chalk in Hydrochloric Acid.*—Carbonic acid is given off, and chloride of calcium and water remain :

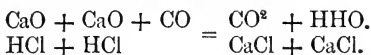

In explaining these two reactions, it has been admitted, much too readily, that the carbonic acid which is *produced* in the experiments necessarily exists, *as such*, in the chalk. When Dr. Black *first made the experiment* of separating chalk into lime and carbonic acid by heat, lime and carbonic acid were not known to be compounds, and he very reasonably drew the conclusions that carbonic acid combined with lime to form chalk, and that chalk was constituted of carbonic acid and lime. But it was not then known that two equivalents of oxygen combined with the carbon to form carbonic acid, and that one equivalent only combined with the calcium to form lime; neither was it known that the quantity of the metal was two equivalents and that of the carbon only one equivalent. Indeed, the possibility of the separation of the chalk into calcium, carbon, and oxygen, and the whole doctrine of chemical equivalents, was not even thought of. To form an accurate theory of the composition of the carbonates was, therefore, at that time impossible. But now that we have a mass of facts and analogies to guide us, we are at liberty to correct opinions that were formed in the absence of accurate information.

3. *The Hydrate of Carbonic Acid.*—We may consider that when carbonic acid is dissolved by water, we have the hydrate of carbonic acid—

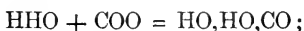

but there is no evidence that this acid exists, for we are unable to concentrate the aqueous solution till the residue acquires this constitution. The acid goes off as gas, and leaves the water free. It is remarkable, however, that between this hypothetical acid and the neutral carbonate we can easily produce the intermediate bicarbonate :

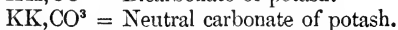
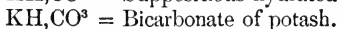
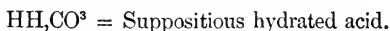

The acid carbonate has precisely the percentage composition corresponding to a double salt, composed of a neutral carbonate combined with hydrated carbonic acid. Thus :

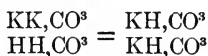

4. *Compound Carbonates.*—The two basic radicals of the neutral carbonates may be different metals. The following are examples:

MgCa,CO³ Carbonate of lime and magnesia.

Ba Ca,CO³ Carbonate of lime and barytes.

5. *Formation of Carbonates by Double Decomposition.*—The carbonates being in all cases bibasic, require for double decomposition two equivalents of any monobasic salt or acid that is brought to act upon them. Example:

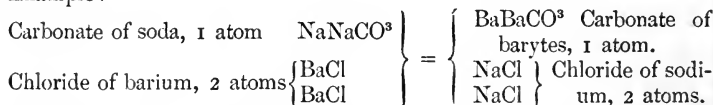

By means of the soluble carbonates of the alcalies, all the insoluble carbonates of the earths and metals can be easily formed by double decomposition, as just described. Other carbonates can be formed by the direct transmission of carbonic acid gas into their solutions. If the substances are in the condition of hydrates, the action is direct and simple, as—

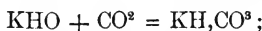

or, when the base is in excess, there is a simultaneous production of water; thus—

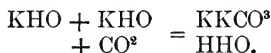

If the substance in solution is a neutral salt, the carbonic acid gas does not decompose it, and produce an insoluble carbonate, unless an alkali be also added; thus, carbonic acid will not alone decompose chloride of calcium, but it will do so if caustic soda be added:

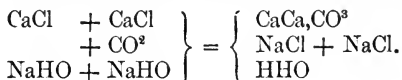

Distinction between Analytical Formulæ and Synoptical Formulæ.

In the preceding pages I have denoted the carbonates by the formula MMCO³, and also by the formula MO + MO + CO. The first formula, MMCO³, expresses all that we certainly *know* of the constitution of the carbonates, and the arrangement of the symbols is conventional. What we *know* is, the nature of the elements and the number of atoms of each of them which are proved by experiment to exist in the compound. As to the arrangement of the symbols, we *agree* to put *first* the electro-positive or basic radicals, and *after them* the electro-negative or acid radical; and, *at the end*, we put the oxygen, because we do not absolutely know where else to put it. This formula gives a synoptical view of our *knowledge* of this compound, and I propose to call it a *synoptical*

formula. It is made in accordance with the rules laid down at page 131.

In the other formula of the carbonates, $MO + MO + CO$, we show what we *conjecture* to be the proximate constitution of the salt. In our *mental analysis* of this salt, we figure to ourselves that it is a compound, first of MO with CO , and then of $MO + CO$ with MO . But conjectures are not facts, mental analysis is purely theoretical, and we cannot experimentally establish the truth of this formula. Nevertheless, the analytical view of the compound assists our comprehension of many phenomena that occur when the salt is decomposed by reactions with other salts; and in many theoretical inquiries, where our judgment must be entirely guided by circumstantial evidence, the *analytical formulæ* of salts can be used with advantage. Let it never be forgotten, however, that the multitudinous analytical formulæ of salts, which can be produced by the play of a lively imagination, represent in all cases only conjectures and not facts.

PROPERTIES OF THE CARBONATES.

The carbonates of the alcalies are soluble in water, and are alkaline in their action on test-paper. The other carbonates are insoluble, but the bicarbonates of the alkaline earths are soluble. The insoluble carbonates are all decomposed at a red heat. The soluble alkaline carbonates do not lose their acid when ignited. The alcalies form crystalline bicarbonates, which are less soluble than the neutral carbonates, and not quite so alkaline in their taste or in their action on litmus. All the carbonates give off gaseous carbonic acid with effervescence when mixed with a strong acid.

Detection of the Carbonates.—See page 95.

Proof of the existence of Charcoal in Carbonates.—The experiment given at page 59 shows the direct introduction of charcoal into a carbonate. The following experiments show the direct extraction of charcoal from a carbonate:—

1. Two parts of chalk in very fine dry powder, and one part of metallic sodium cut into small pieces, are put into an infusible glass test-tube, in such a manner that the sodium is quite enveloped by the chalk. The mixture is heated over a spirit-lamp. An explosion is produced with disengagement of light, but no danger attends the experiment. The mass after this appears quite black, in consequence of the separation of charcoal. If water is added, the mixture becomes hot, and disengages a little hydrogen gas. If diluted muriatic acid is next added, it dissolves the lime and leaves a quantity of charcoal in very fine powder.—*Döbereiner.*

2. If a small piece of metallic potassium is heated in a glass tube, and a current of dry carbonic acid gas is passed over it, the carbonic acid is reduced, and free charcoal is deposited in the state of powder.

If the solid residue of the experiment is dissolved in water, the free charcoal will become visible, and the solution will be found to contain carbonate of potash.

Theory :

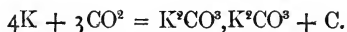

TESTING OF CARBONATES.

The carbonates of potash, soda, lime, and some other bases, occur as natural or manufactured products, in a state of mixture with other bodies destitute of value; and being substances of great importance in the arts, the mixtures have frequently to be subjected to a partial analysis, which consists in determining how much per cent. of the pure carbonate is contained in each mixture. In such cases the process of centigrade testing, the principles of which I have explained in the article at page 97, may often be used with great advantage. I have shown in that article how the standard test liquors are to be prepared; and at pages 112 and 113 I have shown their application to the analysis of carbonates of the alcalies and earths.

There is, however, another method for the analysis of carbonates, which depends upon the ascertainment, by *weight* or *measure*, of the quantity of carbonic acid expelled by another acid from a given weight of the carbonate. These methods give results that are only approximately accurate; but as that is sufficient for many purposes in the arts, the methods are more or less in use.

One reason why the results are inaccurate, when the quantity of disengaged carbonic acid is deduced from the loss in weight of a more or less complex apparatus, is, that the vessels themselves, according to variations in the temperature and the hygroscopic state of the atmosphere to which they are exposed, condense upon their surfaces more or less vapour, and therefore are subject to variations in weight other than that produced by the disengagement of carbonic acid gas.

Kerr's Method of Testing Carbonates by measuring the disengaged Carbonic Acid Gas.—This is an interesting elementary experiment, but not sufficiently accurate for analytical purposes. The glass apparatus is formed in the manner represented by the figure. The end, *a*, is closed

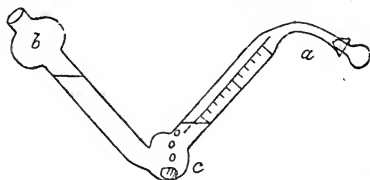

357.

and depressed, muriatic acid is poured in till the vessel is filled above the bend, *c*, and the apparatus is then placed in the position shown in the figure. The solid and weighed carbonate is now dropped in at *b*, and falls to *c*. The disengaged carbonic acid rises in the

branch, *c*, *a*, and drives over the muriatic acid to the branch, *c*, *b*.

When the action is at an end, the bulk of the disengaged carbonic gas may be read off on the scale. The stoppered outlet at *a* is used in cases of analysis, where the *kind* of disengaged gas is unknown, and where, in consequence, small portions of it require to be transferred under water to other vessels for examination. When Kerr's tube is devoted to the examination of carbonates, for example, limestone, the branch, *a, c*, may be closed at the top, and be graduated into 100 parts. The greater the capacity of the tube, the better for use. The same bulk of muriatic acid, and of the same strength, should be used for every charge, and it should be determined by trial how much pure carbonate of lime will disengage a quantity of carbonic acid gas equal to the 100 measures engraved on the tube. This trial is effected easily by determining how many measures of gas are disengaged by pieces of carbonate of lime, weighing respectively 5, 7, and 10 grains. Suppose that 10 grains of pure carbonate of lime, with the fixed dose of muriatic acid, produce exactly the 100 measures of carbonic acid gas, then 10 grains of impure carbonate of lime, with the same dose of muriatic acid, will, in a comparative experiment, produce as many measures of carbonic acid gas as is equal to its percentage of pure carbonate of lime. Thus, 10 grains of a marl, containing equal parts of carbonate of lime and clay, will disengage 50 measures of carbonic acid gas.

Testing of Carbonates, by weighing the Carbonic Acid Gas which they give off when decomposed by another Acid.

1. *Fritsche's Method.*—The figure shows the apparatus, which is formed of thin glass tube. The carbonate is put into one bulb, and the acid, by means of a funnel, into the other bulb. The tubes are then filled with lumps of chloride of calcium, with a little loose cotton put at the bottom of each, and are closed by corks traversed by narrow tubes. The apparatus is first weighed empty, then with the carbonate in it, thirdly, when completely fitted up. It is suspended to the balance by the wire. After being weighed, it is slowly inclined, that the acid may run upon the carbonate and decompose it. The gas escapes by the tubes, but the water is absorbed by the chloride of calcium. When the action is at an end, the mouth is applied to one end of the tube, and air is sucked through the apparatus to force out the residue of carbonic acid. The apparatus is weighed for the fourth time, and the loss of weight shows the quantity of carbonic acid expelled.

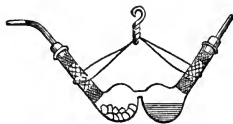

358.

This apparatus has several defects. It permits of only small quantities being examined. It requires careful management to prevent the occurrence of the action of the acid before the whole is prepared. It is fragile. It demands too many weighings. It is difficult to fill it, and

more difficult still to empty it, because every time it is used the chloride of calcium must be removed from the tubes, and these be washed and dried.

2. *Rose's Method*.—*a*, fig. 359, is a very light glass bottle; *b*, a test-tube of thin glass; *d*, a tube containing lumps of dry chloride of calcium. Put a given weight of the dry carbonate into the bottle, *a*. Put into *b* rather more acid than will decompose the carbonate. Adjust *d*, and weigh the whole. Incline the bottle, and allow the acid to mix slowly with the carbonate. Carbonic acid will escape by the tube, *d*, while the water that rises with the gas will be retained, partly in the bulb tube and partly in the tube *d*. The action being at an end, the cork is loosened to allow air

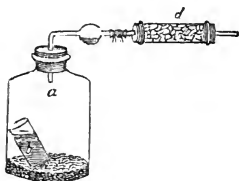

359.

to have access to the bottle, that the carbonic acid may escape. Next day the apparatus is weighed, and the loss of weight shows the quantity of the carbonic acid, from which the quantity of the carbonate can be calculated thus:—

1·0000	part of carbonic acid is equal to,
2·2727	parts of carbonate of lime.
3·1363	parts of carbonate of potash.
2·409	parts of carbonate of soda, <i>dry</i> .
6·5	parts of carbonate of soda, <i>crystallised</i> .

3. *Fresenius and Will's Method*.—The carbonate is weighed and put into the flask A. A quantity of sulphuric acid is put into the flask B.

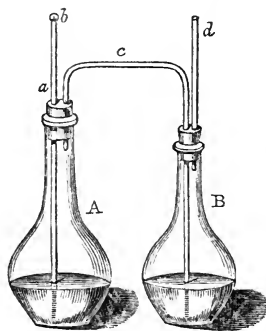

360.

The tubes are then affixed as shown in the figure, where all parts are represented in relative proportions. The point, *b*, is closed by a ball of wax. The whole is then weighed. A small chloride of calcium tube is to be fixed upon the outer end of the tube *d*, and a little air is to be sucked from the flask B by the mouth. This causes air to pass by the tube *c* from A into B. When the mouth is removed, the pressure of the atmosphere at *d* forces a portion of sulphuric acid from B into A by the tube *c*. This acid decomposes part of the carbonate, and the carbonic acid set free passes through the tube *c* into the flask B, and thence into the air. As the

gas passes through the sulphuric acid into which the tube *c* dips, the

carbonic acid is deprived of moisture, and escapes in a dry state. By repeating the suction at *d*, other portions of acid are driven into the flask *A*, until enough is present to decompose the carbonate entirely. When the evolution of gas ceases, the wax is removed from the point *b*, a small chloride of calcium tube is fitted on there, suction is again applied at *d*, and atmospheric air drawn through till it is thought the carbonic acid gas is all expelled from the apparatus. The vessels are then allowed to cool, wiped dry, and weighed. The loss shows the quantity of carbonic acid expelled during the process.

This apparatus is bulky. It requires a scale-pan of nearly 4 inches diameter to contain it; and as sulphuric acid is used, it is only suitable for the testing of alkaline (and not earthy) carbonates.

4. *Geissler's Apparatus*.—This is a modification of the apparatus of Fresenius and Will, made in a single piece, so as to be more easily weighed. The carbonate, with some water, is placed in the bulb *a*, through the opening marked *h*. The sulphuric acid is put into the bulb *b* by the neck *t*. At *d* there is a glass stopcock to regulate the flow of the sulphuric acid. The disengaged carbonic acid gas passes off by the tube *c, c, c*, through the sulphuric in *b*, and away into the air through the tube *t, g*. The point *f* must be closed with a ball of wax during the operation. When the disengagement of carbonic acid ceases, air is to be drawn through the apparatus from *f* to *g*, by suction at *g*.

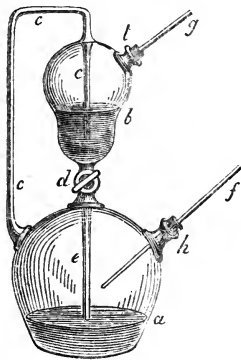

361.

This apparatus can only be used with sulphuric acid; and after each operation it must be completely emptied, which is troublesome.

5. *Another Modification of Apparatus for this Experiment*.—Fig. 362 represents an apparatus which is a little more complicated than the preceding, but which is free from some of their disadvantages. The carbonate that is to be tested is put by the neck *h* into the bottle *A*. The acid by which the carbonate is to be decomposed is put into the tube *a*, whence it is permitted to escape by the stopcock *b* and the bent tube *c*. Nitric acid can be used when desired. The sulphuric acid by which the carbonic acid is to be dried is put into the tube *f* by the mouth *g*. The carbonic acid gas, which is expelled from the carbonate, passes by the bent tube *e* into the sulphuric acid contained in *f*, and thence by the tube *g* into the air. At the end

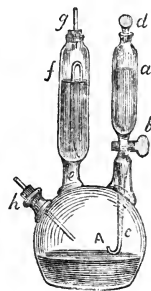

362.

of the operation, air is drawn through the apparatus from *h* to *g*, by suction applied at *g*. As the bottle *A* can be emptied at the end of each operation without emptying the acid tubes, *a* and *f*, and as nitric acid can be used in the tube *a*, this apparatus is more convenient than the others.

6. *Mohr's Apparatus*.—The apparatus represented by fig. 363 was contrived by Dr. F. Mohr. It consists of a wide-necked glass flask,



363.

closed by a cork, which is twice perforated, and which carries in one hole a bulb-tube filled with strong nitric acid, and closed above by a pinch-cock, pressing a caoutchouc connector, and in the other hole a small chloride of calcium drying-tube. The weighed portion of the carbonate that is to be analysed is placed with some water in the flask, the acid is sucked up into the bulb-tubes, and the apparatus being then put together, as shown in the figure, is weighed. The acid is then made to descend slowly by gently squeezing the pinch-cock; and when it has all passed down, the flask is gently warmed, and atmospheric air is sucked through the chloride of calcium tube while the pinch-cock is held open, a second chloride of calcium tube being at the same time connected with the neck of the bulb-tube.

A great many other forms of apparatus have been contrived for the testing of carbonates, but the above give a sufficient idea of the nature of the processes employed.

PROPERTIES OF THE OXALATES.

The composition of oxalic acid is represented by the formula HCO^2 , or, when crystallised, $\text{HCO}^2 + \text{HHO}$. The composition of a neutral oxalate is represented by the formula MCO^2 , in which *M* is the equivalent of any basic radical whatever. The oxalates have a great tendency to combine with one another; that is to say, the neutral oxalates combine with oxalic acid, or with one another. This intercombination goes to such an extent, that a salt is known which contains no less than 18 simple oxalates. Its formula being $13(\text{Am},\text{CO}^2) + 5(\text{MgCO}^2)$, or $\text{Am}^{13}\text{Mg}^5, (\text{CO}^2)^{18}$. That is an extreme case; but common forms of oxalates are—

KCO^2	Neutral oxalate.
$\text{KCO}^2 + \text{HCO}^2$	Binoxalate.
$\text{KCO}^2 + 3\text{HCO}^2$	Quadroxalate.
$\text{KCO}^2 + \text{CuCO}^2$	Double oxalate.
$\text{KCO}^2 + 3\text{CrCO}^2$	Quadruple oxalate.

The neutral oxalates are sometimes anhydrous; but many oxalates contain water of crystallisation. The alkaline oxalates are soluble in

water. The oxalates of the earths and of most of the metals are insoluble; that of lime, $\text{CaCO}^2 + \text{HHO}$, being the most insoluble of all the salts of lime and of all the oxalates. The oxalate of soda is the least soluble of all the salts of soda. Most of the oxalates that are insoluble in water can be dissolved by strong acids. Hence a solution that is to be precipitated by oxalic acid should contain no free acid of another kind. On the contrary, it should contain an excess of ammonia, yet not always, for the oxalates of cobalt and nickel, for example, are soluble in ammonia.

The soluble oxalates are formed by the saturation of oxalic acid with oxides or hydrates. Thus, with caustic potash and oxalic acid we prepare oxalate of potash, $\text{KHO} + \text{HCO}^2 = \text{KCO}^2 + \text{HHO}$. The insoluble oxalates are formed by double decomposition. Thus:

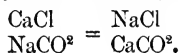

Experiments.

1. Heat a few crystals of oxalic acid on a piece of platinum foil in the open air. They fuse and volatilise entirely without becoming black, or leaving any fixed residue:—

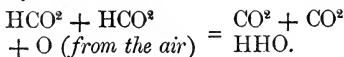

2. To a hot concentrated solution of caustic potash add a hot concentrated solution of oxalic acid till the mixture is neutral, the liquor then contains neutral oxalate of potash:—

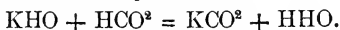

To that mixture add exactly as much more oxalic acid. The mixture will then contain binoxalate of potash = $\text{KCO}^2 + \text{HCO}^2$, which is a crystallisable salt.

3. The oxalates of potash, if calcined on platinum foil, burn without blackening (by which they are distinguished from tartrates), and produce carbonate of potash.

4. A solution of sulphate of lime in water, which is extremely dilute, when mixed with a solution of oxalic acid or oxalate of ammonia, gives a precipitate of oxalate of lime, showing the insolubility of the oxalate of lime.

5. A solution of oxalic acid applied to the brown stains produced by writing-ink on paper or linen removes them. The acid must afterwards be washed away.

Detection of Oxalates. See page 95.

Decomposition.—The oxalates are all decomposed when heated with strong sulphuric acid, giving off carbonic acid and carbonic oxide as gas in equal quantities. See page 357. They are also decomposed when

heated alone, the products of the decomposition being then different, according to the nature of the bases; thus:—

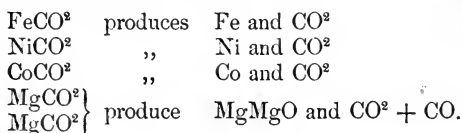

In certain cases the products of the decomposition depend upon the degree of heat at which it is effected. Thus, 2 atoms of CaCO^2 produce—



It might appear, from the above characters, easy to obtain certain metals in a pure state by the simple ignition of their oxalates; but difficulties occur in the execution of the necessary experiments. If, for example, the oxalate of nickel is ignited in a plumbago crucible, there is a disengagement of carbonic acid and a separation of metallic nickel; but simultaneously the nickel takes up carbon from the plumbago crucible, and produces a brittle carburet of nickel. If the operation is effected in any kind of clay or porcelain crucible, the metal combines with the silica of the clay, and destroys the crucible before the fusion can be effected.

OXALIC ACID.

Formula of the Effloresced Acid, HCO^2 ; Equivalent, 45. Formula of the Crystallised Acid, $\text{HCO}^2 + \text{HHO}$; Equivalent, 63. The atomic measure of gaseous oxalates is 1 volume, because the radical C measures nothing when in salts.

Occurrence.—In the juice of wood-sorrel, and in many other plants in combination with potash or lime.

Preparation.—Pour six parts of nitric acid of 50° upon one part of refined sugar or starch, and boil the mixture in a retort. Carbonic acid gas and nitric oxide gas will be disengaged in large quantities. Distil over the greater part of the acid, and then allow the liquor in the retort to cool, whereupon the oxalic acid will be deposited in crystals. The operation can also be performed in a porcelain basin, when the gases and nitric acid are not to be collected. Drain these crystals from the acid liquor, dissolve them in hot water, evaporate and recrystallise. This may be repeated till the oxalic acid is pure. Four parts of sugar yield one part of oxalic acid. The crystals should be perfectly white, and when ignited in a platinum capsule should leave no residue. It is, however, very difficult to free oxalic acid from a trace of potash, which is derived from the sugar or starch from which it is made. The crystals

that are first deposited in a crystallising solution of oxalic acid contain more potash than the main crop of crystals. The following figures represent porcelain drainers adapted to separate crystals from their mother-liquor.

The solution of sugar in nitric acid is practised in the large way by manufacturers of oil of vitriol for the sake of the nitric oxide gas which it affords, and which is necessary for

the conversion of sulphurous acid into sulphuric acid, as will be explained in the section on Sulphur. The oxalic acid is obtained as a secondary product.

Properties of Oxalic Acid.—Clear colourless crystals, very acid, but not unpleasant in taste. Dissolve in 9 parts of cold water, but in a much less quantity of hot water; a saturated solution at 62° F. is something less than 12° strong. See page 106. One part of oxalic acid in 200,000 parts of water reddens blue litmus. The crystals effloresce in the air. In a moderate heat the effloresced acid can be sublimed in glass vessels for the most part undecomposed. But the effloresced and sublimed acids are never so constant in their composition as the crystallised acid. Heated to 212° F. the crystals give off water and melt, and at 311° F. the acid boils and is decomposed, producing carbonic acid and carbonic oxide as gas, and a solution of formic acid in water. It is also decomposed by hot oil of vitriol. See page 356.

A weak solution of oxalic acid has an agreeable acid taste, and may be drank with perfect safety; but in the state of a concentrated solution it is a deadly poison. In the crystallised state it has much the appearance of Epsom salts; instead of which it has sometimes been taken accidentally, and proved fatal. The mode of distinguishing oxalic acid from Epsom salt is as follows:—1. Taste the solution: Epsom salt is bitter; oxalic acid extremely sour.—2. Pour a little tincture of litmus into the solution: if Epsom salt be present, the blue colour will remain unchanged; if oxalic acid be present, the blue will be turned to red.—3. Tincture of cabbage, or any other coloured vegetable infusion, or a slip of litmus test-paper, are all acted upon by the acid (which changes their colours), but not by the salt.—4. Oxalic acid, when dropped into water, makes a *crackling noise*, which Epsom salt does not. The best antidote to a dose of it is an emetic, aided by copious draughts of warm water, containing chalk, or common carbonate of magnesia.



364.



365.

ULTIMATE ANALYSIS OF ORGANIC COMPOUNDS.

As oxalic acid contains the three elements which are common to a vast number of organic compounds—carbon, hydrogen, and oxygen—I will give an account of the mode of analysing it, so as to determine in

what proportions these three important elements are combined together in this salt. According to the formula given above, the composition of crystallised oxalic acid is as follows:—

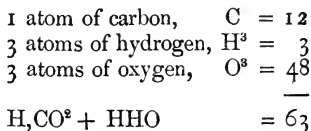

The following are the experiments by which this formula is justified:—

Combustion of Oxalic Acid.—Take 21 grains of dry crystals of oxalic acid, reduced to fine powder; mix it with 20 or 30 times its weight of pure black oxide of copper, recently calcined and perfectly dry; place it in a tube of infusible Bohemian glass of the form shown by fig. 366,

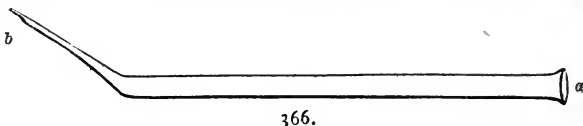

and by *a*, *b*, in fig. 367. This tube is to be about 24 inches long and $\frac{5}{8}$ inch in diameter, open at the end *a*, and closed at the bent contracted end *b*. Above the mixture you are to put black oxide of copper, until the tube is filled within an inch and a half of the end *a*, and the tube, so filled, is to be placed on an iron furnace, such as is represented in fig. 367, and is to be connected by means of a very sound cork, or with a stopper made of vulcanised caoutchouc, with the glass tube vessels shown at letters A, B, C. The tube A is to contain fragments of pumice-

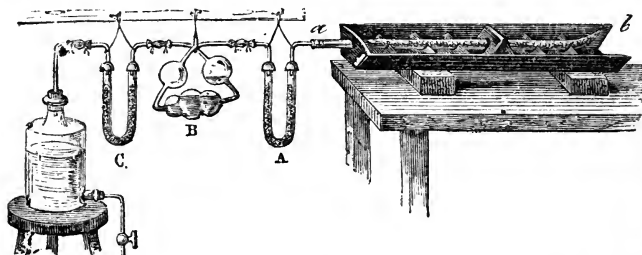

367.

stone saturated with concentrated sulphuric acid; the bulbs B are to contain a concentrated solution of caustic potash; the tube C is to be filled with fragments of pumice-stone saturated with concentrated solution of caustic potash. Finally, you are to connect the end of the tube C with an aspirator, not, however, as is represented in fig. 367, but with the intermediate tube that is represented by letter I, in fig. 223,

page 222; which intermediate tube is to be filled with fragments of pumice-stone, saturated with concentrated sulphuric acid, in order to prevent the passing back of vapour of water from the aspirator into the tube C.

The tube A is to be weighed by itself. I will call the weight P. The tubes B and C are to be weighed together. Their weight is found to be P'. Of course, these weights include the contents of the tubes as prepared for the subsequent process.

The apparatus being thus arranged, you are to heat to redness, by means of a charcoal fire, that portion of the tube *a, b*, which contains the oxide of copper that is unmixed with organic matter; and when the oxide of copper is become red-hot for a length of six or eight inches, you are gradually to permit the charcoal to become ignited about that portion of the tube *a, b*, which contains the mixture of oxide of copper with oxalic acid. The decomposition of that acid then soon commences. At a red heat the oxide of copper is reduced to metallic copper, and gives up to the organic substance the quantity of oxygen which is required to convert its carbon into carbonic acid, and its hydrogen into water. These are the only products of the resulting decomposition. The mixture of carbonic acid gas and vapour of water passes into the tubes A, B, C. The sulphuric acid contained in the tube A retains the vapour of water, but not the carbonic acid gas. This passes into the tubes B and C, where it is absorbed by the caustic potash, most of it in the bulb apparatus B, and the residue in the U-tube C. You are to continue and extend the application of the red-hot charcoal until the tube *a, b* is ignited from end to end. The combustion of the oxalic acid will then be at an end, and the gas will cease to bubble into the apparatus B. Some care is now required in the management of the bulbs to prevent the solution in them from passing backwards into the tube A; but as I am not giving such detailed instructions as would be necessary to enable you correctly to perform an ultimate analysis, but only such as serve to explain the principles upon which an ultimate analysis is founded, I pass over the details of manipulation, which can be found in works expressly devoted to that subject.

The carbonic acid gas, and the vapour of water produced by the combustion of the oxalic acid, are not entirely absorbed by the liquors placed in the three tubes A, B, C; a little still remains in the combustion-tube *a, b*, which it is necessary to drive thence into the absorption-tubes. You manage this as follows:—Remove the charcoal from the closed end of the tube *b*, and when this portion is become cold, you are to break off the tip of it, and immediately to apply, with the help of a caoutchouc joint, a tube of the form of fig. 368, containing fragments of caustic potash. At the same time water is allowed to escape from the aspirator by opening its stopcock. A current of atmospheric air is thus drawn through the whole apparatus. This air deposits both

its water and its carbonic acid with the caustic potash placed in the tube, fig. 368. It passes thence, in a pure and dry state, into the combustion-tube, *a, b*, carries

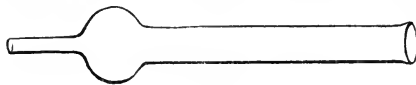

368.

with it the vapour and carbonic acid still remaining in that tube, and proceeds thence through the tubes

A, B, C, depositing in its passage the vapour and the carbonic acid which it thus sweeps out of the tube *a, b*, into their proper receptacles. In this manner about a quart of water is to be suffered to escape slowly from the aspirator. The whole of the products of the combustion of the oxalic acid will by that time be condensed in the absorption-tubes, and the operation is ended. The flow of water is then to be stopped, and the tubes are to be detached and weighed.

1. The weight of the sulphuric acid tube, *A*, in which the water has been condensed, may be called *Q*.

2. The joint weight of the tubes, *B* and *C*, in which the carbonic acid has been absorbed by caustic potash, may be *Q'*.

It is evident that the water produced by the combustion of 21 grains of oxalic acid must weigh $Q - P$, and that the carbonic acid produced by the same combustion must weigh $Q' - P'$.

If the experiment has been correctly performed, you will find the weights to be—

$$Q - P = 9 \text{ grains.}$$

$$Q' - P' = 14.67 \text{ grains.}$$

Now, 9 grains of water contain 1 grain of hydrogen, and 14.67 grains of carbonic acid contain 4 grains of carbon; and since oxalic acid contains nothing else than hydrogen, carbon, and oxygen, it follows that the 21 grains submitted to analysis consist of—

Hydrogen . . . 1 grain.

Carbon . . . 4 grains.

Oxygen . . . 16 grains.

To determine the relation of the equivalents of the three elements which exist in oxalic acid, you have to divide these weighed quantities, each by the chemical equivalent of the element. You thus find—

$$1 \div 1 = 1 \cdot = \text{hydrogen.}$$

$$4 \div 12 = .333 = \text{carbon.}$$

$$16 \div 16 = 1 \cdot = \text{oxygen.}$$

These numbers are equivalent to—

Hydrogen 3

Carbon 1

Oxygen 3

Consequently, to H^3CO^3 . This is the teaching of *ULTIMATE analysis*, which shows us only the ultimate atoms that are present in a compound,

and not how these atoms are arranged into PROXIMATE constituents. By other experiments, to be presently described, you are able to prove that crystallised oxalic acid is separable into water and the oxalate of hydrogen, or into



Beyond that all is theory or conjecture, both as respects the composition of the salt, $\text{H} + \text{CO}^2$, or $\text{HO} + \text{CO}$, and of the water, $\text{H} + \text{HO}$, as I have fully explained in preceding sections.

Separation of the Water of Crystallisation from Oxalic Acid.

When the crystals of oxalic acid are heated they give off a certain quantity of water, and produce the effloresced or the sublimed salt. The result of the exposure to the action of heat is that 63 grains of $\text{HCO}^2 + \text{HHO}$ produce about 45 grains of HCO^2 , the quantity of water, HHO , given off being about 18 grains. When the heating takes place in the open air the product is never exact or constant; but it is possible to secure accuracy by the process which follows:—

Put into a bent glass tube, of the form shown by fig. 369, and the wide part of which is about 3 inches long and 1 inch in diameter, a quantity of dry pulverised crystals of pure oxalic acid. The tube, previously made clean and dry, is first weighed empty, then the pulverised acid is put into it, and it is again weighed. You must take care not to soil the wide neck of the tube through which the powder is inserted. I will suppose, as before, that you operate upon 21 grains of the crystallised acid, very accurately weighed. The bent tube, fig. 369, is then to be placed in the position shown by *a, b, c, d*, in fig. 370, where *a*

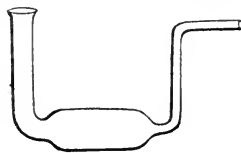

369.

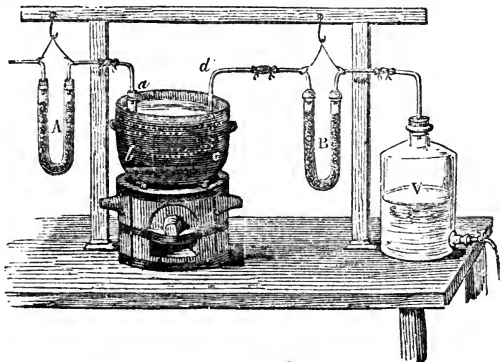

370.

shows the wide end of the tube and *d* the narrow end. The flask V is an aspirator for drawing air through the apparatus. The bent tube A is filled with fragments of pumice-stone, saturated with concentrated sulphuric acid. The tube B is prepared in the same manner. The bent tube, *a, b, c, d*, is placed in an iron bath, placed over a furnace, and containing water, which is kept boiling. The same apparatus is used when higher degrees of heat are required, and in each case the particular degree of heat is regulated by the kind of liquor that is heated in the iron bath. Thus, while water boils at 212° F., other water, saturated with common salt, boils at 230° F., while oil affords a heat of upwards of 500° F. A mercurial thermometer, fig. 371, plunged into the bath shows its temperature at any moment, and by a judicious management of the fire, any desired intermediate degree of temperature can be readily obtained.

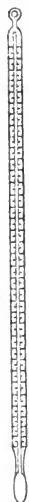

371.

When the stopcock of the aspirator is opened, water escapes and atmospheric air is drawn through the apparatus in the direction of A, *a, b, c, d*, B, V. The air is dried in the tube A, and passing in a dry state into the heated tube *a, b, c, d*, it readily takes up a quantity of water from the crystals, as much, if the operation is continued long enough, as the crystals are able to yield up at 212° F. When the aspirator V is empty, the tube *a, b, c, d*, is removed, wiped dry, and carefully weighed, with its contents. The difference between the two last weighings shows how much water the crystals have yielded to the current of air that has passed over them in the hot bath. But it is a precautionary necessity to ascertain whether the crystals, if exposed to the same degree of heat for a longer period, would lose an additional quantity of water. To determine this point, the tube, *a, b, c, d*, is replaced in the bath, the vase, V, is refilled with water, and the operation is repeated. When the vase is again empty, the bent tube is again weighed. If the weight is the same as

before, it shows that the acid has lost all the water which it can lose at that temperature; but if the weight shows that there has been a further loss of water, the operation must be repeated a third time, and even again, until two successive weighings show the same result.

On operating in this way on 21 grains of crystals of oxalic acid, we find a loss of 6 grains, which is equal to a loss of 18 grains from 63 grains, and, therefore, justifies the formulæ which I have given above, namely—

Hydrogen . . .	$H^1 = 1$	
Carbon . . .	$C^1 = 12$	
Oxygen . . .	$O^2 = 32$	—
EFFLORESCED ACID		$= 45$
WATER {	Hydrogen $H^2 = 2$	
	Oxygen . $O^1 = 16$	—
CRYSTALLISED ACID		$= 63 = HCO^2 + HHO.$

ANALYSIS OF THE OXALATES.

In some cases there is a difficulty in distinguishing between the oxygen and hydrogen which form the water of crystallisation of an organic acid, and corresponding quantities of the same two elements forming part of the compound radicals contained in the acid. The chemical equivalent of an acid is, therefore, never fixed, without an analysis being performed on some of its salts that contain a fixed basic radical, such as potassium, barium, lead, or silver.

If we take a solution of oxalate of potash, and mix it with a solution of nitrate of lead, we obtain a white precipitate which is oxalate of lead, the formula of which, as can be demonstrated by a direct analysis, is Pb,CO^2 . The first step in this analysis consists in weighing a quantity of the dried oxalate of lead in a platinum crucible, and making it red hot over a spirit-lamp. The oxalate is decomposed, and oxide of lead remains :

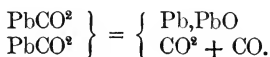

The second step of the analysis consists in repeating the process of combustion with oxalate of lead instead of oxalic acid, observing all the precautions which I have just detailed. The result affords no water, because there is no hydrogen present in dried oxalate of lead; but it affords a quantity of carbonic acid commensurate with the quantity of carbon shown by its composition = $PbCO^2$, which yields,

$$\left. \begin{array}{l} \text{Lead} \quad Pb^1 = 103 \cdot 5 \\ \text{Carbon} \quad C^1 = 12 \\ \text{Oxygen} \quad O^2 = 32 \end{array} \right\} = 147 \cdot 5$$

By two comparative analyses we consequently come to this result:—

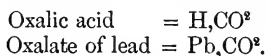

And from these data it is concluded that the replaceable hydrogen of the oxalic acid is in the condition of its basic radical, and that the acid radical of the oxalates consists of carbon alone.

THE OXALATES AND CARBONATES OF AMMONIA, AND THE COMPOUNDS PRODUCED BY THEIR DECOMPOSITION.

A. *The Oxalates of Ammonia.*

There are three varieties of oxalate of ammonia, which, in the state of crystals, have the following composition:—

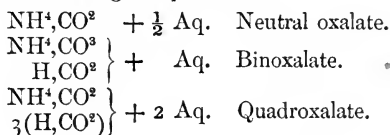

The whole of these can be deprived of their water of crystallisation by careful heating at 212°F . The neutral salt can be made by neutralising a solution of oxalic acid with ammonia or carbonate of ammonia. The binoxalate precipitates when a solution of oxalic acid is added to a solution of the neutral oxalate. The quadroxalate is formed by crystallising a solution which contains equal parts of the crystallised binoxalate of ammonia and crystallised oxalic acid.

Oxamid.—When neutral oxalate of ammonia is subjected to dry distillation in a retort, it suffers a decomposition, which may be represented as follows:—

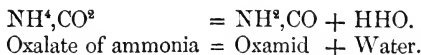

The products of the decomposition are water, and a new salt, which contains amidogen instead of ammonium, and only one atom of oxygen instead of two atoms. Other products of decomposition, afforded by other atoms of the oxalate, appear at the same time and complicate the process, and, indeed, this is not the best means of preparing oxamid, but I quote it for theoretical considerations, as it affords an idea of one of the methods by which salts of ammonium are converted into salts of amidogen, namely, by the abstraction, at a high temperature, of two atoms of hydrogen and one atom of oxygen in the state of one atom of water.

Oxamid is a white crystalline powder, without taste or odour, or action on test-papers. It is insoluble in water. When heated gently in a glass tube it sublimes. When heated strongly it fuses, and is ultimately decomposed, affording a great variety of compounds, according to the degree of heat at which the decomposition is effected. When its vapour is passed through a long glass tube, heated to redness, it affords the following products:—

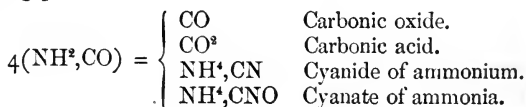

When oxamid is boiled with a diluted acid, such as sulphuric, nitric, or hydrochloric, the amidogen is again converted into ammonium, which combines with the radical of the strong acid. Thus:—

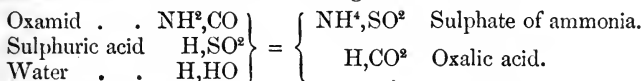

When oxamid is heated with potassium, an inflammation occurs, and the products are cyanide of potassium and water:—

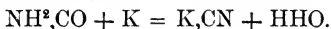

When oxamid is boiled with a solution of caustic potash, ammonia is disengaged, and oxalate of potash is formed:—

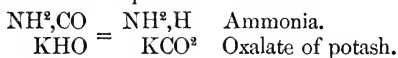

When oxamid is put with water into a glass tube, and this is sealed hermetically, and heated to 435° F., the oxamid is converted into oxalate of ammonia:—



We have in these experiments clear demonstration of the facts, that ammonium can be readily reduced to amidogen, and amidogen again be readily restored to the condition of ammonium. The interest of these decompositions lies in this, that similar effects occur with the compound ammoniums that are formed by organic radicals, and also with other acid radicals than carbon, and these transmutations give origin to a great variety of remarkable compounds.

Oxamates.—Just as the neutral oxalate of ammonia can be deprived of an atom of water, and be converted thereby into *oxamid*, so can the binoxalate of ammonia be deprived by a similar process of an atom of water, and be converted into a substance which has been called *Oxamic Acid*:—

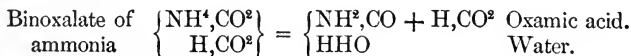

This oxamic acid is, in fact, a double salt composed of the neutral salt oxamid = NH²,CO, combined with unaltered oxalic acid = H,CO², and this oxalic acid retains its usual saturating power, and can exchange its basic hydrogen for any other basic radical, such as NH⁴, Ba, Ca, Ag, &c. Thus, the oxamate of ammonia has the formula NH²,CO + NH⁴,CO², and the oxamate of ethyl is NH²,CO + C²H⁵,CO².

The oxamic acid is white, crystalline, granular; it dissolves very sparingly in cold water. When its aqueous solution is boiled, its amidogen is reconverted into ammonium, and the oxamic acid again becomes binoxalate of ammonia:—

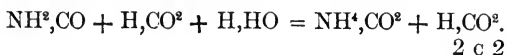

Neutral Oxalate of Ammonia deprived of two equivalents of Water. Origin of Cyanogen.—When neutral oxalate of ammonia is deprived of two atoms of water, it is reduced to the condition which is shown in the following equation:—



All that is left of the salt is the acid radical C, and the azotic atom N, which was the prime agent of the compound positive radical ammonium, but which, in its isolated state, is a powerful negative radical. These two atoms, thus freed from oxygen and basic radicals, combine together and produce cyanogen, which is usually marked CN or Cy. This compound is not a salt composed of two radicals, but a single acid radical, energetic in its chemical powers, yet having the saturating capacity of only one atom. This fact is worthy of particular notice, because nitrogen and carbon have *each* separately the saturating capacity of one radical, though, when combined, they have *together* only the saturating capacity of one radical. Thus nitrogen, which, in positive radicals, paralyses the saturating capacities of the two or four radicals with which it produces amids and ammons, has its own saturating capacity paralysed when it enters into a negative radical in company with carbon.

B. *The Carbonates of Ammonia.*

I have shown, in the section on the Carbonates, that there are two kinds of carbonates, the *neutral* and the *acid*. These two varieties, when containing ammonium, must have the following composition:—

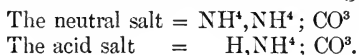

The neutral salt exists, as such, only in its aqueous solution. When any attempt is made to dry it, an atom of water goes off, and we obtain an amidogen salt. Thus:—



which may be compared to a combination of oxamid with an oxide of ammonium:— $\text{NH}^2, \text{CO} + \text{NH}^4\text{O}$.

Carbamic Acid.—When gaseous ammonia is made to act on gaseous carbonic acid, there occurs a condensation in the proportion of two volumes of carbonic acid gas to four volumes of ammonia gas, producing the following result:—



This compound has been called carbamate of ammonia, and it has been assumed that it contains the *carbamic acid*, an imaginary acid, of the existence of which we have no proof, and which is a phantom with

which we need not trouble ourselves. The systematic nomenclature which I have recommended would supply this compound with a name that would express its constitution without calling in the assistance of any myth whatever:—

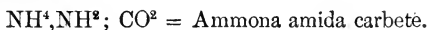

All the known carbonates of ammonia are compounds of the three substances here named. There are a good many varieties resulting from the facility with which the two normal salts give off more or less, HHO, and so introduce complex mixtures. I have investigated the subject fully in my work on the Radical Theory. Here, I will only notice the common carbonate of ammonia of commerce, which has the formula,



This is usually called the sesquicarbonate, but it is erroneously so called, since the true sesquicarbonate should have the formula,



When the sesquicarbonate of commerce is dissolved in water, it may be assumed to take up HHO, and to be converted into this regular salt.

Carbamid.—If we suppose an equivalent of neutral carbonate of ammonia to be deprived of two equivalents of water, we have for residue a substance which has been called *carbamid*:—



Cyanate of Ammonia, or Urea.—I do not agree with the conclusions presented by the last equation. It appears to me that the residue afforded by the process should be arranged as follows —

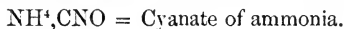

This substance, of artificial formation, is identical with an important animal substance which occurs in urine, and is known by the name of Urea.

The reasons which guide me in forming the opinion that carbamid does not exist are detailed in my work on the Radical Theory, in the articles on Carbamid, Urea, and the Carbamates.

Reconversion of the Nitrogen of Cyanogen into the Ammoniacal condition.

I have shown that the nitrogen contained in the oxalates and carbonates of ammonia can be converted into cyanogen, and be made to produce cyanides and cyanates. It is necessary to call attention to the corresponding fact, that the nitrogen of cyanogen can be reciprocally converted into the condition of amidogen and ammonium. The play of affinities which thus transfers nitrogen from positive radicals into nega-

tive radicals, and thence back again into positive radicals, is of immense importance in all the operations which concern organic compounds. There can be little doubt that many of the transmutations which occur in living plants and animals are due to the active chemical agency of the element nitrogen.

Examples :

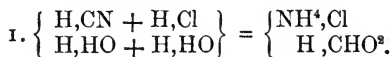

One atom of hydrocyanic acid, one atom of hydrochloric acid, and two atoms of water, produce one atom of chloride of ammonium, and one atom of hydrated formic acid = H,CHO^2 .

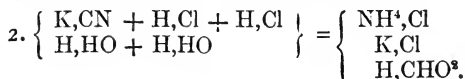

One atom of cyanide of potassium, two atoms of hydrochloric acid, and two atoms of water, produce one atom each of chloride of ammonium, chloride of potassium, and hydrated formic acid.

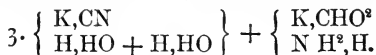

One atom of cyanide of potassium boiled in a close vessel with two atoms of water produces one atom of ammonia and one atom of formiate of potash.

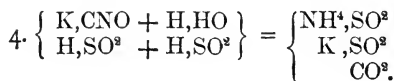

One atom of cyanate of potash, one atom of water, and two atoms of hydrated sulphuric acid, produce one atom each of sulphate of ammonia, sulphate of potash, and free carbonic acid.

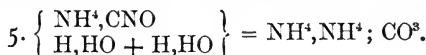

One atom of urea (cyanate of ammonia), heated in a sealed tube with two atoms of water, produces one atom of carbonate of ammonia.

6. See page 357, process 4.

ORGANIC COMPOUNDS.

I propose to give here a slight sketch of organic chemistry: to show, as briefly and as clearly as I can, some of the methods by which the hand of Providence builds up from the four elements, carbon, hydrogen, nitrogen, and oxygen, the multitudinous beautiful objects which constitute the living world. No doubt my account will be very imperfect. There is no room, in an elementary work like this, to give illustrative details on all points of so immense a subject; nor would my knowledge enable me to approach completeness were I to attempt it. I shall confine myself to a limited range of topics, such as I hope will give the student distinct general notions of the nature of organic chemistry, and of the relative importance and general bearings of its different branches. More than general notions it would be vain to attempt to give.

Nature has ordained that the elements carbon and hydrogen shall together constitute a series of compounds which are called *compound radicals*, and which act in organic chemistry a part similar to that which is acted in mineral chemistry by the substances which we call *elements*, or *elementary radicals*. These radicals, therefore, command our attention. Combined with one another, with oxygen, with nitrogen, and with many mineral radicals, they produce a great variety of salts, which also command our attention.

For the sake of brevity, and in order to convey comprehensive notions of each branch of the subject, I shall, as far as possible, group both the radicals and their salts into such masses as will show their relative importance and their dependence upon one another.

As it will be necessary to quote a good number of examples, and as space cannot be spared to describe each in detail, a few important compounds of each class will be selected for special description, to serve as illustrations of the whole.

In the main, therefore, what I have to say will fall under three heads. 1.) An account of the organic radicals which are procurable from vegetable and animal bodies. 2.) An account of the groups or series of compounds which they produce by intercombination. 3.) Special descriptions of the most important and characteristic compounds of each series.

The difficulties of organic chemistry arise less from the number of its particular facts, than from the complexity and the perplexities of its too abundant theories and hypotheses. In the present sketch I intend to adhere as logically as I can to a single theory, according to which all the phenomena will be explained. I allude to the "Radical Theory,"

upon which I have recently published a comprehensive treatise, to which I must refer those readers who wish to investigate the experimental evidence and arguments upon which are founded the important conclusions that are used in this work as chemical axioms.

NEUTRAL ORGANIC COMPOUNDS.

A great proportion of the solid mass of plants, and of the substances dissolved in their juices, consists of compounds which contain carbon united to those quantities of oxygen and hydrogen which are necessary to compose water. Thus, $C + HHO$. We can account for the production of such compounds in plants by assuming that water = HHO and carbonic acid = COO , which are the main food of plants, combine together under separation of that quantity of oxygen which is not required for the constitution of these compounds, or the health and growth of the plants of which they form a portion. The separation of a portion of the oxygen, and the combination of the residues of the carbonic acid and water, appear to take place in the cells of the leaves of the plants when they are exposed to sunshine. The two compounds, $COO + HHO$, give off OO , and produce $CHHO$. That, under such circumstances, growing plants *do* give off oxygen gas in large quantities was ascertained many years ago, and is a fact easy of verification by experiment. But whether the compound CH^2O is or is not formed as I suggest, it is at present impossible to determine. I suggest it as possible, and even probable. The product, CH^2O , appears to me to be the oxide of the important neutral radical which I have called **VINYL** = CH^2 . Accordingly, I propose to give to this compound the systematic name of *Vinylate*, which corresponds with the formula CH^2O .

The relation borne by *Vinylate* to certain important neutral vegetable substances may be expressed as follows:—

CH^2O , *Vinylate*. This is the composition of fructose, sugar of fruits, or grape sugar, and no doubt of the sweet juices of a vast number of plants. It is the substance upon which they grow, that which yields them their nourishment; in short, it is the blood of plants.

A slight change in composition converts this blood of plants into the fixed solids which give to plants their stability, and also into some of the compounds which render plants suitable for the food of animals.

CH^2O . *Milk sugar, undried.*

$C + (CH^2O)^4$. *Dried milk sugar.*

$C + (CH^2O)^4 + HHO$. *Milk sugar, undried.*

This last formula is merely 5 times CH^2O .

$C + (CH^2O)^5$. *Starch, cellulose, woody fibre; such as pure flax, cotton, or paper.*

- $C + (CH^2O)^5 + HHO, HHO$. *Glucose*, starch sugar. This composition may also be rendered by the formula $(CH^2O)^6 + Aq.$, namely, 6 atoms of vinylate with 1 atom of water.
- $C + (CH^2O)^2$. *Lignin*; but this compound is of variable composition when procured from different plants.
- $C + (CH^2O)^7$. *Inulin*. Starch from chicory, dahlia, &c.
- $C + (CH^2O)^{11}$. *Cane sugar*. Also gum arabic (arabin).

Here we have a series of most important compounds, comprehending woody fibre, the gums, starches, and sugars—the solid structure of trees, the sweet juices of plants, and even the sweet principle of milk, all of which seem to be reducible to compounds of vinylate, united, atom after atom, to a single atom of carbon = $C + CH^2O + CH^2O + CH^2O, CH^2O, \&c.$, just as in the composition of amidogen and ammonium those compounds are formed by the successive combination of atoms of hydrogen with a single atom of nitrogen. See page 313.

It is impossible to glance over this little list of compounds without being struck with amazement at the extreme simplicity of the arrangement by which the wisdom of Providence guides the atoms of carbon, oxygen, and hydrogen to produce compounds that are so important, and that lead to such beneficial results. How wonderful it is that the sweet juice which nature so readily produces from carbonic acid and water should be the chief food of plants, that it should also be a prime ingredient in the milk which nourishes the young of animals, and that this sweet juice should be capable of ready transformation into the solid starches which form so considerable a part of corn, rice, potatoes, and other articles used for food, into the honey of the bee, into sugar, and also into the vegetable fibre which gives us those important substances, wood, cotton, linen, paper—the materials for our fires, our dwellings, our dresses, our books!

But Nature has not only made those compounds of great simplicity of constitution, she has given to man the power of modifying them; and though this power has only yet been partially mastered, it shows that hereafter man may be able to convert to his service the products of vegetable life more effectually than he has done hitherto. When, for example, the compounds which contain multiples of vinylate are deprived of that single atom of carbon which gives to each of them its individual peculiarities, they are all reduced to the condition of vinylate or grape sugar. Thus, when cane sugar is acted on by an alkali or an acid, the atom of carbon is removed and grape sugar remains. This is the reason why much of the sugar which is contained in the sugar-cane is reduced to grape sugar in the process of extracting and crystallising the cane juice. So, also, when starch or woody fibre, such as a piece of linen, is acted on by an acid, the atom of carbon is removed, and grape sugar is produced. It would be an important discovery in the chemical arts if

we could find a method of reversing this operation—if we could raise the lower orders to the higher orders of organic compounds—if we could combine with a multiple of atoms of grape sugar that odd atom of carbon which is needful to produce cane sugar, starch, or woody fibre. That is, however, at present beyond the power of the chemist, not only in this case, but in nearly all cases. He can reduce complex compounds to compounds of a more simple form; but in only a few rare examples can he perform the reverse operation of raising simple forms to those of a complex nature. That he can do it even in a few cases affords reasonable hope for greater successes hereafter.

COMPOUND ORGANIC RADICALS.

It appears, from these and other considerations, that vinylate, or the simplest form of sugar, is the nutritive principle of plants, the material which is employed to form the various radicals which the different orders of plants, and the different organs of each plant, demand for their support. The metamorphoses of the sugar probably takes place in the cells of the green leaves, of the blossoms, or of the fruit; in those parts, namely, where it is acted upon by the light and heat of the sun, and where it is able to disengage its superfluous oxygen. It is difficult to form a precise idea of the processes by which this change of sugar into radicals, or into salts composed of radicals is effected. Probably the walls of the cells, in which the operations occur consist of azotic substances, which give them the power of galvanic batteries. It is possible that the azote of those cells may be endowed with very active powers, and may, according to certain conditions of osmose, regulated by light, heat, air, and water, run incessantly backwards and forwards through its various characters of amidogen-, ammonium-, and cyanogen-former, and thus repeat in each particular cell those processes of construction and transformation of radicals which I have endeavoured to describe and classify. Millions of such cells exist in a tuft of grass or the twig of a plant. It is known that they are azotic; it is known that azotic cells have a powerful action even on dead vegetable matter (as in fermentation); it is known that plants grow vigorously after a thunder-storm; and these conditions are all favourable to the idea that the conversion of sugar into compound radicals is the work of azote acting with intense electrical force in the cells of plants exposed to air and light.

The conversion of vinylate—the sweet juice or the blood of plants—into the compound radicals, or the salts of the compound radicals, which are required for the constitution of the different parts of each plant, is attended by the discharge of a remarkable quantity of oxygen. The juices of plants, and the materials of their solid structure; their woods lignins, starches, and gums, are largely provided with oxygen; but the compounds which give to plants their distinctive peculiarities—the causes of their infinitely various tastes, odours, colours, their invigorating

and their poisonous properties—contain a very much smaller proportion of oxygen, and in some cases none at all. The oxygen thus given off when vinylate is converted into radicals or salts, does not remain accumulated in the plants, for no compounds have been found in them surcharged with oxygen. It goes into the atmosphere, from which the plants derive their supply of carbonic acid, and thus keeps up the quality of the air by which the earth is enveloped. When the oxygen is disengaged, the residue of the components of sugar can produce an astonishing variety of radicals which differ according to the wants of the plants, or to other special circumstances which lead to their production. I will quote a few instances; but, first of all, I must premise the explanation, derived from the observation of what *generally* (but not always) occurs, that *whatever number of atoms of vinylate is acted upon to produce the required result, all the oxygen is disengaged, except two atoms, and all the carbon and hydrogen are converted into two radicals, a basic radical and an acid radical, the former of which, as compared with the latter, contains an excess of hydrogen, while the latter contains an excess of carbon.*

Examples of Salts, each containing two Radicals, produced from a multiple of Vinylate minus O².

When jargonelle pears are in course of ripening, the compound which gives them their odour and flavour is produced by the metamorphosis of 7 atoms of CH^2O minus O^2 . The product is $\text{C}^5\text{H}^{11}, \text{C}^2\text{H}^3\text{O}^2$, which I may call amyla acetylete, or the acetate of amyl, a compound which is now made artificially, and sold under the name of pear-oil or essence of jargonelles. In the production of this essence, one atom of sugar is divided into $\text{H} + \text{CH}$. 5 atoms of CH^2 then become attached to the odd atom of H, producing the basic radical amyl = C^5H^{11} , and 1 atom of CH^2 to the atom of CH, producing the acid radical acetyl = C^2H^3 . For this salt, and for all the salts of the vinyl series, only two atoms of oxygen are required, so that all the rest of the oxygen belonging to the atoms of vinylate which are required to produce the salt must be disengaged.

All the ethereal essences which give fragrance and flavour to ripening fruits appear to be produced in the same manner. Thus:—

$\text{C}^5\text{H}^{10}\text{O}^2$, the residue left by expelling O^3 from five atoms of sugar, produces $\text{CH}^3, \text{C}^4\text{H}^7\text{O}^2$ = methyla butyrylete, or the butyrate of methyl, which is the essence of the apples called rennets.

$\text{C}^{10}\text{H}^{20}\text{O}^2$ produces $\text{C}^8\text{H}^{11}, \text{C}^2\text{H}^9\text{O}^2$ = amyla valerylete, or valerianate of amyl, the essence of other varieties of apples.

$\text{C}^8\text{H}^{12}\text{O}^2$ produces $\text{C}^6\text{H}^5, \text{C}^2\text{H}^7\text{O}^2$ = ethyla butyrylete, or the butyrate of ethyl, the oil which yields the delightful flavour of the pine-apple, and is also used as essence of rum.

$C^{11}H^{22}O^2$ produces $C^2H^5, C^9H^{17}O^2$ = ethyla pelargylete, or the pelargonate of ethyl, which is the essence of quinces. It is said to occur in many wines.

$C^9H^{18}O^2$ produces $C^2H^5, C^7H^{13}O^2$ = ethyla cœnanthylete, or cœnanthylate of ethyl, an oil which gives flavour to Hungarian wine. It is probable that the flavour of many other wines may thus be imitated.

$C^9H^{18}O^2$ also produces $C^5H^{11}, C^4H^7O^2$ = anyla butyrylete, or the butyrate of anyl, which is the oil of cognac.

These preparations are now extensively used by perfumers, confectioners, and manufacturers of liqueurs. I might add to the list such compounds as

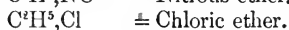
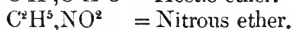
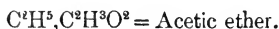

All of which also are used by perfumers and druggists, for the sake of their odour or flavour.

The metamorphoses of sugar into these fragrant essences is only a single example selected from a multitude of possible changes. The Table of Examples on the opposite page exhibits a more enlarged view of these interesting metamorphoses.

According to this Table, the metamorphoses of 4 atoms of sugar can produce 4 different complete salts, each with a different acid radical and a different basic radical. Which of these four compounds is producible on any given occasion, depends upon the wants of the plant, upon its power of metamorphosis, or upon other causes which it is impossible to specify.

In the same manner, 8 atoms of sugar produce 8 different salts. 12 atoms of sugar produce 12 different salts. 16 atoms produce 16 salts. 30 atoms produce 30 salts. Hence it appears, that any number of atoms of sugar can produce by metamorphoses an equal number of different salts, each salt containing two different radicals.

Several particulars resulting from these observations require notice.

a). In all the groups of this Table, every acid radical is combined with a different basic radical. This fact proves that these radicals are exchangeable or equivalent, and that, whatever their composition, however high or however low they stand in the scale, their power of neutralisation is the same. Every radical in the series is chemically equivalent to every other radical, and the replacement of the most complex by the most simple is attended by no change in neutrality.

b). We perceive the utter worthlessness of *unitary formulæ* as applied to organic salts. The unitary or clump formula $C^{16}H^{32}O^2$ applied to a compound of the vinyl series, signifies SIXTEEN DIFFERENT SALTS, and every similar unitary formula signifies *as many different salts as it contains atoms of carbon*, of which fact, the unitary formula gives no intimation.

PRODUCTS OF THE METAMORPHOSES OF SUGAR.

From $C^4H^8O^2$ = 4 atoms of Sugar minus O^2 .	From $C^8H^{16}O^2$ = 8 atoms of Sugar minus O^5 .	From $C^{12}H^{24}O^2$ = 12 atoms of Sugar minus O^{10} .	From $C^{16}H^{32}O^2$ = 16 atoms of Sugar minus O^{14} .
H, $C^4H^7O^2$	H, $C^8H^{15}O^2$	H, $C^{12}H^{23}O^2$	H, $C^{16}H^{31}O^2$
$C^1H^3, C^3H^5O^2$	$C^1H^3, C^7H^{13}O^2$	$C^1H^3, C^{11}H^{21}O^2$	$C^1H^3, C^{15}H^{29}O^2$
$C^2H^5, C^2H^3O^2$	$C^2H^5, C^6H^{11}O^2$	$C^2H^5, C^{10}H^{19}O^2$	$C^2H^5, C^{14}H^{27}O^2$
$C^3H^7, C^1H^1O^2$	$C^3H^7, C^5H^9O^2$	$C^3H^7, C^9H^{17}O^2$	$C^3H^7, C^{13}H^{25}O^2$
	$C^4H^9, C^4H^7O^2$	$C^4H^9, C^8H^{15}O^2$	$C^4H^9, C^{12}H^{23}O^2$
	$C^5H^{11}, C^3H^5O^2$	$C^5H^{11}, C^7H^{13}O^2$	$C^5H^{11}, C^{11}H^{21}O^2$
	$C^6H^{13}, C^2H^3O^2$	$C^6H^{13}, C^6H^{11}O^2$	$C^6H^{13}, C^{10}H^{19}O^2$
	$C^7H^{15}, C^1H^1O^2$	$C^7H^{15}, C^5H^9O^2$	$C^7H^{15}, C^9H^{17}O^2$
		$C^8H^{17}, C^4H^7O^2$	$C^8H^{17}, C^8H^{15}O^2$
		$C^9H^{19}, C^3H^5O^2$	$C^9H^{19}, C^7H^{13}O^2$
		$C^{10}H^{21}, C^2H^3O^2$	$C^{10}H^{21}, C^6H^{11}O^2$
		$C^{11}H^{23}, C^1H^1O^2$	$C^{11}H^{23}, C^5H^9O^2$
			$C^{12}H^{25}, C^4H^7O^2$
			$C^{13}H^{27}, C^3H^5O^2$
			$C^{14}H^{29}, C^2H^3O^2$
			$C^{15}H^{31}, C^1H^1O^2$

From $C^{30}H^{60}O^2 = 30$ atoms of Sugar minus O^{23} .

H, $C^{30}H^{57}O^2$ Hydra melissylete.	$C^{15}H^{31}, C^{15}H^{29}O^2$? benylete.
$C^1H^3, C^{29}H^{57}O^2$ Methyla ?	$C^{16}H^{33}, C^{14}H^{27}O^2$ Cetyla myristylete.
$C^2H^5, C^{28}H^{53}O^2$ Ethyla ?	$C^{17}H^{35}, C^{13}H^{25}O^2$? cocinylete.
$C^3H^7, C^{27}H^{53}O^2$ Propyla cerotylete.	$C^{18}H^{37}, C^{12}H^{23}O^2$? laurylete.
$C^4H^9, C^{26}H^{51}O^2$ Butyla ?	$C^{19}H^{39}, C^{11}H^{21}O^2$? margaritylete.
$C^6H^{11}, C^{25}H^{49}O^2$ Amyla ?	$C^{20}H^{41}, C^{10}H^{19}O^2$? rutylete.
$C^6H^{13}, C^{24}H^{47}O^2$ Hexyla ?	$C^{21}H^{43}, C^9H^{17}O^2$? pelargylete.
$C^7H^{15}, C^{23}H^{45}O^2$ Heptyla ?	$C^{22}H^{45}, C^8H^{15}O^2$? caprylete.
$C^8H^{17}, C^{22}H^{43}O^2$ Octyla ?	$C^{23}H^{47}, C^7H^{13}O^2$? cenanthylete.
$C^9H^{19}, C^{21}H^{41}O^2$ Nonyla behenylete.	$C^{24}H^{49}, C^6H^{11}O^2$? caproylete.
$C^{10}H^{21}, C^{20}H^{39}O^2$ Decatyla arachylete.	$C^{25}H^{51}, C^5H^9O^2$? valerylete.
$C^{11}H^{23}, C^{19}H^{37}O^2$ Endecatylabalenylete	$C^{26}H^{53}, C^4H^7O^2$? butyrylete.
$C^{12}H^{25}, C^{18}H^{35}O^2$ Dodecatyla stearylete	$C^{27}H^{55}, C^3H^5O^2$ Ceryla propionylete.
$C^{13}H^{27}, C^{17}H^{33}O^2$? margarylete.	$C^{28}H^{57}, C^2H^3O^2$? acetylete.
$C^{14}H^{29}, C^{16}H^{31}O^2$? palmitylete.	$C^{29}H^{59}, C^1H^1O^2$? formylete.

The sign ? indicates that the radicals are undiscovered or unnamed.

c). We have a complete exposition of Berzelius's doctrine of *metamerism*, a term by which he indicated "the case in which the compound atoms of two chemical compounds containing the same elementary atoms, and for the most part in the same proportions, are nevertheless made up of different proximate elements." We see in the present Table 5 complete metameric groups, and we perceive both the cause and the extent of the metamerism, and can therefore complete other groups at our pleasure.

d). The note of interrogation in Group 5 of the Table, shows the position and composition of the radicals of the vinyl group which have not yet been recognised. Of course, these radicals are unnamed, which accounts for the blanks in the names of the salts of this group.

I proceed now to direct the reader's attention to the relations which the organic radicals bear to one another. I have arranged in the Table which commences at page 400 all the radicals that have been well discriminated, and a few even of those which depend upon uncertain evidence. They are grouped so as to show their mutual relationships, to distinguish the members that are known, and mark the places of those that certainly exist but have not yet been discovered. This schedule shows to a chemist what a chart of the world shows to a navigator. It is his pilot or guide.

At first sight, the number of these radicals appears to be considerable; but, after the separation of those that are unknown, and those that are doubtful, we find the number of well-ascertained organic radicals not to exceed the number of inorganic radicals particularised in the Table printed at pages 126-128. So small a number of radicals seem to bear no proportion to the infinite number of organic compounds which are now known to exist, the details of which fill large systematic books composed of many volumes. But it is to be remembered, that the great mass of organic substances does not consist of free radicals, but of combinations of those radicals with one another, with inorganic radicals, and with oxygen. The workings of Nature in the organic world are, in this respect, perfectly analogous to her operations in the mineral world. We everywhere around us see *Compounds*—living or dead bodies—mineral, vegetable, animal—nearly all are compounds. The radicals and elements are the invisible spirits which work within them, and which must be exorcised by art and skill to be rendered visible. The magical power of the chemist is required to call them from their vasty deeps; and sometimes, when they are called, they do not come.

THE PRINCIPLE UPON WHICH THE COMPOUND RADICALS ARE CLASSIFIED.

The radicals are arranged in groups according to the method of grouping them which is most in use among organic chemists, that is to

say, in agreement with the series of formulæ commonly marked $n\text{CH}^2 + \text{H}^1$, $n\text{CH}^2 - \text{H}^1$, $n\text{CH}^2 - \text{H}^2$, $n\text{CH}^2 - \text{H}^3$, &c.

I wish it, however, to be understood, that these headings do not represent my opinion of the constitution of the radicals that are placed below them. If these formulæ represent the *result*, they certainly do not represent the *order*, of Nature's proceedings. If Nature has to produce a hill, she certainly does not in the first instance produce a mountain and then cut it down. The early crystallographers supposed that if Nature wanted to produce an octahedron, she first produced a cube, and then cut off all its corners till nothing remained of its original faces but a mathematical point in the centre of each. In like manner, these organic formulæ appear to assume, that if Nature desires to produce a radical, such as cumyl for example, she first combines together 10C and 20H into the compound $\text{C}^{10}\text{H}^{20}$, and then takes away H^2 , and leaves the desired result $\text{C}^{10}\text{H}^{11}$. I renounce that method of explanation, believing that Nature's process to be, in all cases, that of adding atom to atom one by one till she reaches the desired point. She never overworks herself, in order to be forced to undo what she has done amiss.

Throughout the Table, proceeding from above downwards, every radical exceeds the one above it by the addition of CH^2 , proving that the same relation which holds true among the radicals of the vinyl series, quoted in groups A and B, holds equally true in all the other series; the differences being confined to the constitution of the first radical, or starting point of each group. This principle of a common difference among a series of radicals is what Gerhardt calls *HOMOLOGY*. Every group in the Table is, in his terms, an *Homologous series*.

The radicals which are marked k in the Table are known to chemists, if not in an isolated state, at least in some form of combination.

I have admitted into the Table the radicals of the so-called bibasic and tribasic acids; but, strictly speaking, these should be rejected from the Table, because they are actually double and triple radicals, and appear again in their single forms in other groups of the Table. Read the discussion of this topic in groups C. and D.

Most of the radicals in the Table have an uneven number of atoms of hydrogen, and only those which have that composition seem to possess an atomic measure when they form part of gaseous salts. The salts of vinyl CH^2 , of succinyl C^2H^2 , of salicyl C^7H^4 , when in the gaseous state measure only as much as is due to the other radicals with which they are in combination.—See page 138.

Chemical Equivalence of the Compound Radicals.—The compound radicals quoted in the Table are the chemical equivalents of the elementary radicals contained in the Table inserted at page 126. Whatever may be the complexity of the constitution of a compound radical—whatever the number of its atoms of carbon and hydrogen, whether it

be C^1H^1 or $C^{30}H^{61}$ —it forms only one radical; its chemical action is that of one molecule, one atom, one equivalent. When it acts as an acid radical, it replaces one volume of chlorine or combines with one volume of hydrogen. When it is a basic radical, it combines with one volume of chlorine, or replaces one volume of hydrogen. A compound radical containing only carbon and hydrogen, and consisting of $nCH^2 + H$, or $nCH^2 + CH$, is in all respects the chemical equivalent of one atom, or one volume, of any element, except oxygen.

Discrimination of Compound Radicals into Acid Radicals and Basic Radicals.—Experience proves that compound radicals are, like elementary radicals, separable into the two orders of Acid radicals and Basic radicals; that certain of them invariably act as substitutes for basic metallic radicals, and certain others act just as invariably as substitutes for the metalloidal radicals of acids. In most cases, this difference is sharp and decisive, but in others, particularly when organic radicals are compared with other organic radicals, it is sufficiently uncertain to render it proper to lay down some kind of rule according to which *the difference between basic radicals and acid radicals* may be recognized. I have proposed (*Radical Theory in Chemistry*, page 73) to settle this difficulty by making the following assumptions:—

1. That carbon acts as an acid radical; that hydrogen acts as a basic radical; and that radicals containing the two elements act as acid or basic, according as the carbon or the hydrogen exceeds a certain proportion.

2. That the compound CH^2 is one in which the acid properties of the carbon are neutralised by the basic properties of the hydrogen. This compound is *olefiant gas*, called by Berzelius *elayl*, and by Gmelin *vine*, a term which might with convenience be translated into VINYL, which term I propose to employ.

3. Compound radicals that contain any proportion of hydrogen *greater* than that of H^2 to C^1 , are BASIC. Those that contain any proportion of hydrogen *less* than that of H^2 to C^1 , are *acid*. Thus—

$C^{30}H^{61}$ = Myricyl . . . A basic radical.

CH^2 = Vinyl . . . Neutral.

$C^{30}H^{59}$ = Melissyl . . . An acid radical.

I speak only in a general sense, and do not mean to give to this observation the character of a fixed and absolute law. But supposing the law to be only approximately true, it may, notwithstanding its irregularities, serve in organic chemistry the same purpose that Berzelius's electrochemical arrangement of the elements serves in inorganic chemistry; namely, as a formal guide in the arrangement of basic and acid radicals. Notwithstanding the irregularities that occur, it is evident that we may, with propriety, decide between any two radicals, that the one which contains the greater proportion of hydrogen is the more basic of the two.

According to this rule, methyl is more basic than ethyl, ethyl than propyl, propyl than amyl, and so on, through the whole range of the hydrocarbons. There are exceptions to this rule, but perhaps not more than occur in Berzelius's electro-chemical list of the elements. It is a great point gained, if, setting oxygen aside, we can, from the mere inspection of the formulæ of the hydrocarbons, distinguish the basic from the acid.

The present uncertain practice of chemists in their dealings with salt radicals shows the necessity of adopting some decisive method of distinguishing the basic radicals from the acid. When Professor Williamson discovered his compound ethers, he was unable to name them in accordance with any commonly understood system; and consequently he gave to each compound a series of synonymes. Thus the compound which contained $\text{C}^3\text{H}^5\text{O}$ was called the *three carbon ether*, the *ethylate of methyle*, and the *methylate of ethyle*. Now upon the principle that we have just laid down, methyl must, in all cases, be held to be basic against ethyl, the relation of the hydrogen to the carbon being 3 to 1 against $2\frac{1}{2}$ to 1. Hence, the difficulty of naming the compound is avoided, and our memories are spared the infliction of useless synonymes.

It would be easy to refer to innumerable examples in the writings of Gerhardt, which show the want of this principle of classification. He finds, for example, a compound containing benzyl and acetyl, with three atoms of oxygen = $\text{C}^9\text{H}^3 + \text{C}^7\text{H}^5 + \text{O}^3$, and he calls it "*acetic benzoate* or *benzoic acetate*." Again, he finds a similar compound containing acetyl and cumenyl = $\text{C}^2\text{H}^3 + \text{C}^{10}\text{H}^{11} + \text{O}^3$, and he is uncertain whether to call it *acetic cuminate* or *cuminic acetate*. Such difficulties are immediately resolved by the rule that has been proposed, according to which acetyl is to be considered as decidedly basic towards both benzyl and cumenyl.

Before I proceed to the Table of Radicals, I may with propriety give some account of the agent which seems to be employed by Nature in the construction of the compound radicals, and which is also one of the most frequent products resulting from their decomposition.

THE NEUTRAL COMPOUND ORGANIC RADICAL. VINYL = CH^2 .

Synonymes.—*Olefiant Gas*. *Heavy Carburetted Hydrogen Gas*. *Elayl*. *Ethylene*. *Etherine*. *Vine*.

Formula, CH^2 ; *Equivalent*, 14; *Specific gravity of gas*, 14; *Atomic measure when isolated*, 1 volume; *Atomic measure when acting as a radical in salts*, 0; *Condensing action on other radicals*, 0.

Properties.—A gas. Colourless and transparent. Commonly possessing an unpleasant empyreumatic odour, due to impurities. Insoluble

in water. Unfit to support respiration or combustion. Burnt at a jet in the air, it gives a brilliant white flame of great illuminating power. Mixed with oxygen or air, and fired, it explodes with extreme violence. It also explodes when mixed with chlorine and fired. The products of the combination with oxygen are carbonic acid and water. 1 volume of the gas takes 3 volumes of oxygen gas to burn it, $\text{CH}^2 + \text{O}^3 = \text{CO}^2 + \text{HHO}$, the products of the combustion being 2 volumes of carbonic acid, and 2 volumes of steam. It follows, that 1 volume of this gas requires the oxygen of 15 volumes of atmospheric air for its combustion, and leaves in the atmosphere 2 volumes of carbonic acid gas, 12 volumes of nitrogen gas, and 2 volumes of vapour of water, in all 16 volumes of gases unfit for respiration.

Preparation.—This gas is prepared as follows:—Take one ounce of strong alcohol and four ounces of concentrated sulphuric acid. Em-

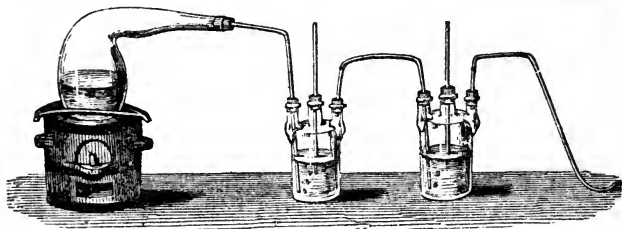

372.

ploy a gas bottle or retort of the capacity of at least ten ounces. Add the acid to the alcohol, a little at a time, and shake the bottle after each addition, to mix the liquids properly, and to prevent heating. The mixture becomes brown, and, on being cautiously and very gradually heated, disengages olefiant gas. This operation requires a good deal of care, for, unless the heat be well regulated, the mixture is very apt to boil over. If the heat is raised too rapidly, part of the alcohol is driven off undecomposed. The gas comes off when the liquor boils. The brown liquor gradually becomes black and thick, from precipitated charcoal. The operation must then be stopped. The gas is purified by washing, first with water, and then with a weak solution of potash, or by being passed through oil of vitriol. It can be collected over water.

Theory :

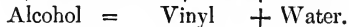
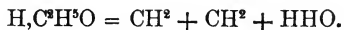

The composition of alcohol is represented by the formula $\text{H,C}^2\text{H}^3\text{O}$, which is equal to $2\text{CH}^2 + \text{HHO}$; that is to say, 1 equivalent of alcohol contains the elements of 2 equivalents of olefiant gas and 1 equivalent of water. When this is boiled with concentrated sulphuric acid, the

water is abstracted and the olefiant gas is set at liberty. In practice, however, the decomposition is not effected so simply, but part of both the reagents is decomposed, under production of sulphurous acid gas, free charcoal, and ether.

Olefiant gas is an important ingredient of coal gas. It also sometimes occurs in the fire-damp of coal mines, and a large quantity of it is produced when oily substances are exposed to a red heat in close vessels. Thus it is that *oil-gas* is produced, the brilliant illuminating power of which is owing to the large proportion of olefiant gas it contains.

The subject of coal gas will be treated of in the section on Combustion.

EXPERIMENTS WITH OLEFIANT GAS.

1. This gas burns with great brilliancy when inflamed at the mouth of a narrow tube, as may be observed in the combustion of the coal gas and oil gas commonly used to illuminate shops, those gases being mixtures of olefiant gas with some other gases.

2. Collect the gas prepared from alcohol in a jar, such as fig. 198, *a*. To the stopcock *g* of that jar adapt a brass jet of the form figured in the margin. Transfer the jar to a deep water-trough, such as a pail. Open the stopcock *g*, apply a light to the jet, and gently press the jar down into the water. The gas will burn with a brilliant white flame like a common gas-light.

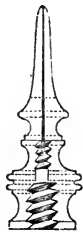

373.

3. If an inflamed taper is held to the mouth of a large jar, *a*, fig. 374, filled with olefiant gas, the gas takes fire, and produces a large and brilliant flame. To expel the gas from the jar, and make it all burn at the mouth, water may be poured in from another vessel, of equal capacity, *b*.

4. Collect the olefiant gas in a glass cylinder, open and ground flat at both ends. Close the upper end of it with a ground glass plate smeared with tallow. Transfer the cylinder to a deep-water bath. Take off the glass cover, immediately apply a light, and press the cylinder down into the water. A large and brilliant flame is thus produced.

5. Mix 1 volume of olefiant gas with 3 volumes of oxygen gas, put the mixture in a bottle, wrap the bottle in a thick cloth, and apply a light to the mouth; upon which the mixture will explode. $\text{CH}^2 + \text{O}^3 = \text{HHO} + \text{CO}^2$. As this explosion is extremely violent, only small quantities of the mixed gases should be

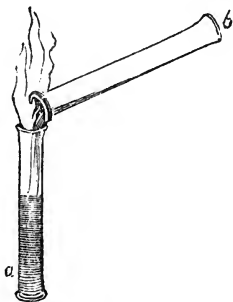

374.

fired at once. The mouth of the bottle must be turned away from you. See page 205.

6. The same mixture may be exploded by the electric spark. See pages 206 and 215. But it is difficult to perform the experiment in a glass eudiometer, without breaking it.

7. The mixture may be blown into soap-bubbles in an iron mortar, as described at page 205. These bubbles produce a very loud explosion when fired.

8. These experiments may be made with a mixture of 1 measure of olefiant gas and 15 measures of air, or of 1 measure of common coal gas with 8 or 10 measures of atmospheric air.



375.

9. Burn a little of the gas in a plain jar, and pour lime-water into the jar; carbonate of lime will be formed. The carbonic acid produced by the combustion of this gas may also be collected in the manner described at page 346.

10. When 1 volume of olefiant gas is mixed with 2 volumes of chlorine gas, and immediately inflamed, the olefiant gas is decomposed, hydrochloric acid is formed, and charcoal is deposited in powder (soot).

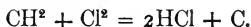

Invert a tall and wide cylinder, filled with water, over the water-trough. Fill one-third of it with olefiant gas, and the residue of it with chlorine gas.

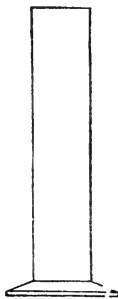

376.

Cover the mouth of the jar, which should be ground, with a greased glass plate, and invert the jar several times to mix the gases. This experiment must be made at night, because the mixture is liable to explode in sunshine. Set the jar on its foot, remove the glass cover, and apply a light; the gas will burn with a red flame, which proceeds slowly downwards, and deposits a thick coat of carbon upon the glass.

11. Prepare a similar mixture of chlorine gas and olefiant gas in the same glass cylinder. Bend a stout copper wire at a right angle, so that one branch of it shall be able to dip half way into the cylinder. Cover the lower end of this wire very loosely with a leaf of Dutch gold. Remove the cover from the cylinder, and dip the leaf gold into the mixed gases. Spontaneous inflammation occurs, with a beautiful appearance, and the charcoal is deposited over the whole vessel.

12. As combustible gases burn in an atmosphere of oxygen gas, so, in like manner, will oxygen gas, or atmospheric air, burn in an atmosphere of combustible gas. Take the cylinder and jet described in experiment 2, fill the cylinder with common air, press it down in water, and open the jet. Bring over the jet a small bottle of olefiant gas.

Just when the mouth of the bottle is in contact with the jet, apply a light. Immediately depress the bottle so as to bring the jet into the middle of the bottle. Blow out the flame at the mouth of the bottle. The atmospheric air will continue to burn at the jet amid the atmosphere of olefiant gas, or, in other words, the olefiant gas will burn where air comes into contact with it.

13. In the same manner may a jet of chlorine gas be made to burn in an atmosphere of olefiant gas, or coal gas. A dull yellow flame is produced, which soon becomes invisible, in consequence of the dense mass of charcoal deposited upon the jar.

SALTS OF VINYL.—THE GLYCOL THEORY.

Familiarity breeds contempt. As it is in common life, so it is in science. Chemists are so familiar with the radical vinyl, that they treat it with indifference. Without colour, when it is present they do not see it. Without odour and without taste, it never bites them, and they neither feel it nor fear it. If they are forced to give some account of the compounds in which vinyl occurs, they still resolve to ignore it, and that they may be able to do so with some appearance of propriety, they double its formula, give the doubled formula a new name, sometimes ethylene, sometimes glycol, and proceed as if vinyl was not in existence—as if it did not give conclusions far more rational and formulæ infinitely more simple than those which are adopted as explanations of the reaction of ethylene or of glycol. The practice, so common among organic chemists, of needlessly doubling the formulæ of compounds, and working out results with complicated masses of figures, to the neglect of obviously simple formulæ, is much to be deplored. I have investigated the Glycol Theory in my treatise on the Radical Theory, and I shall confine myself here to the quotation of the formulæ and names of a few of the compounds of vinyl.

In all cases the common names which I have quoted intimate twice as many atoms of every element as appear in the following formulæ. If these compounds are considered as compounds of vinyl, that duplication is in every instance improper.

The name which immediately follows the formula is the systematic name prescribed by the Radical Theory.

A). When the salts contain no oxygen, chemists are accustomed to call them salts of ethylene.

1. CH^2, Cl . *Vinyla chlora*. Chloride of ethylene. Hydrochloric ether of glycol. The atomic measure of this salt in the state of gas is one volume, because the vinyl, having an even number of atoms of hydrogen, loses its measure in salts.
2. CH^2, I . *Vinyla ioda*. Biniodide of ethylene.
3. CH^2, Br . *Vinyla broma*. Dibromide of ethylene. The atomic measure of the gas is one volume.

4. CH^2, S . Vinyln sulphur. Sulphide of ethylene.
 5. $\text{CH}^2, \text{S} + \text{HS}$. Vinyln sulphur cum hydra sulphur. Sulphohydrate of ethylene. The atom of H is replaceable, so that it can produce metallic salts.
 6. $\text{CH}^2, \text{CyS}^2$. Vinyln cyana sulphur. The sulphocyanide of ethylene.
- B). But when oxygen comes into action with the same radical, then the radical suddenly becomes entitled to the name of glycol.
7. $\text{H}, \text{CH}^2\text{O}$. Hydra vinylate. Glycol.
 8. $\text{CH}^2, \text{CH}^2\text{O}$. Vinyln vinylate. Oxide of ethylene. Ether of glycol.
 9. $\text{C}^2\text{H}^5, \text{CH}^2\text{O}$. Ethyln vinylate. Diethylglycol. Diethylene of glycol.
 10. $\text{CH}^3, \text{CH}^2\text{O}$. Methyln vinylate. Dimethylene of glycol.
 11. $\text{C}^2\text{H}^5, \text{CH}^2\text{O} + \text{CH}^3, \text{CH}^2\text{O}$. Ethyln vinylate cum methyln vinylate. A compound of Nos. 9 and 10.
 12. $\text{CH}^2, \text{C}^2\text{H}^3\text{O}^2$. Vinyln acetylate. Diacetate of glycol. The following is the usual formula by which Wurtz shows this salt to be a Diacetate:— $\left. \begin{array}{l} \text{C}^4\text{H}^4 \\ \text{C}^4\text{H}^3\text{O}^2 \\ \text{C}^4\text{H}^3\text{O}^2 \end{array} \right\} \text{O}^4$.
 13. $\text{CH}^2, \text{C}^2\text{H}^3\text{O}^2 + \text{H}, \text{CH}^2\text{O}$. Vinyln acetylate cum hydra vinylate. Monoacetate of glycol. This is evidently a double salt, containing No. 7 in combination with No. 12.
 14. $\text{H}, \text{CH}^2\text{O} + \text{CH}^2, \text{Cl}$. Hydra vinylate cum vinyln chlora. Chlorhydrate of glycol. A compound of Nos. 1 and 7.
 15. $\text{CH}^2, \text{C}^2\text{H}^3\text{O}^2 + \text{CH}^2, \text{Cl}$. Vinyln acetylate cum vinyln chlora. Chloracetate of glycol. A compound of No. 12 with No. 1. This compound forms a gas, the atomic weight of which is 122.5, and its specific gravity 61.25; so that its atomic measure is two volumes. That is the measure of the acetyl and the chlorine, the two atoms of vinyl and the oxygen measuring nothing.
 16. $\text{CH}^2, \text{C}^2\text{H}^3\text{O}^2 + \text{CH}^2, \text{I}$. Vinyln acetylate cum vinyln ioda. Iodacetate of glycol. A compound of No. 12 with No. 2.
 17. $\text{CH}^2, \text{C}^4\text{H}^7\text{O}^2 + \text{CH}^2, \text{Cl}$. Vinyln butyrylate cum vinyln chlora. Chlorbutyrate of glycol.
 18. $\text{CH}^2, \text{C}^2\text{H}^3\text{O}^2 + \text{CH}^2, \text{C}^4\text{H}^7\text{O}^2$. Vinyln acetylate cum vinyln butyrylate. Butyrate of glycol. Evidently a double salt, composed of acetate and butyrate of vinyl.
 19. $\text{CH}^2, \text{C}^7\text{H}^5\text{O}^2$. Vinyln benzoylate. Benzoate of glycol. More correctly, benzoate of vinyl.
 20. $\text{CH}^2, \text{C}^7\text{H}^5\text{O}^2 + \text{CH}^2, \text{Cl}$. Vinyln benzoylate cum vinyln chlora. Chlorbenzoate of glycol. A compound of No. 19 with No. 1.

The constitution of these salts is so evident, so simple, and so much in accordance with the general laws of chemical combination, that no necessity exists for, and no advantage results from, any other mode of interpretation than that which represents them to be salts of vinyl. The doubling of the formula of vinyl, the assumption that the doubled formula represents here ethylene, and there glycol, according as oxygen is absent or present, the elevation of glycol so made to the rank of a *biatomic alcohol*, and the homage paid to it as the first of a series of important and previously unheard-of organic compounds, afford altogether a strange example of the whimsicalities which excite the credulity of chemists, and lead them into perplexities.

I add a short notice of the chloride of vinyl. The other salts of this series will be found described in the recent chemical journals.

Chloride of Vinyl. Dutch Liquid. Oil of Olefiant Gas. Chloride of Ethylene. Hydrochloric Ether of Glycol.

Formula, CH².Cl; Equivalent, 49.5; Specific Gravity of Gas, 49.5; Atomic Measure, 1 volume. Systematic name, Vinyla Chlora.

Suspend a glass bottle, filled with olefiant gas, by means of the ring of a retort stand, so that its mouth shall be under the water contained in a basin, without resting on the basin. Place below the mouth of the bottle a flat porcelain capsule. Bring into the mouth of the bottle the end of the bent gas-delivering tube of a bottle in which chlorine gas is being prepared. Chlorine gas comes thus into contact with olefiant gas and moisture, and gradually combines with the olefiant gas, producing an ethereal or oily liquid, having the composition CH² + Cl. The gas gradually disappears, the water rises in the bottle, the oil floats at first on the surface of the water, but having a sp. gr. of 1.22, it soon sinks down into the capsule placed to receive it. At 152° F. this oil forms a gas whose specific gravity is 49.5, so that it has an atomic measure of one volume, which is that of its chlorine, the vinyl, having an even number of atoms of hydrogen, loses its atomic measure when it is a constituent of gaseous salts. See page 138.

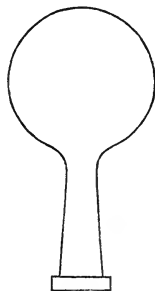

377.

CLASSIFICATION OF COMPOUND RADICALS.

PRELIMINARY NOTE RESPECTING THE VINYL SERIES OF RADICALS.

GROUP A. *Basic Radicals of the Vinyl series.*GROUP B. *Acid Radicals of the Vinyl series.*

Nos. 1 to 60 in the following Table.

Any given quantity of atoms of grape sugar (vinylate) = $n\text{CH}^2\text{O}$, can, while in the living plant, give off all its oxygen except two atoms, and be simultaneously converted into a salt containing two radicals, one basic and one acid. I have, in Group 5, page 389, traced this reaction as far as 30 times CH^2O . I might have gone a step further, since we know in myricyl, No. 30 in the following list, a radical, the composition of which goes beyond any of those named in page 138. This radical, myricyl = $\text{C}^{30}\text{H}^{61}$, is the most complex that has been hitherto discriminated.

On examining the radicals of GROUP A, it will be seen that they are all multiples of CH^2 plus a single atom of H. In like manner the radicals of GROUP B are all multiples of CH^2 plus a single atom of CH. It would seem as if, when any quantity of CH^2 was to be converted into two radicals, one atom of CH^2 was split into the two characterising radicals H and CH, and that the multiple of CH^2 , with which H combined, became a basic radical, while that multiple of CH^2 with which CH combined became an acid radical, and this without reference to the absolute quantity of CH^2 which, in any case, entered into combination with either C or CH.

It follows from this uniformity of constitution, and of the properties which depend upon constitution, that the basic radicals of GROUP A are related one by one to corresponding acid radicals in GROUP B, and that *theoretically*, whatever may be the case *practically*, the two classes of radicals are convertible the one into the other on the following grounds.

1. If you take from a radical of GROUP A two atoms of hydrogen, it is converted into a radical of GROUP B. Thus:—

Methyl $\text{C H}^3 - \text{H}^2 = \text{C H}$, Formyl.Ethyl $\text{C}^2\text{H}^5 - \text{H}^2 = \text{C}^2\text{H}^3$, Acetyl.Amyl $\text{C}^5\text{H}^{11} - \text{H}^2 = \text{C}^5\text{H}^9$, Valeryl.

2. If you take from a radical of GROUP B a single atom of carbon, you convert it into a radical of GROUP A. Thus:—

Acetyl $\text{C}^2\text{H}^3 - \text{C} = \text{C H}^3$, Methyl.Propionyl $\text{C}^3\text{H}^5 - \text{C} = \text{C}^2\text{H}^5$, Ethyl.Valeryl $\text{C}^5\text{H}^9 - \text{C} = \text{C}^4\text{H}^9$, Butyl.Oenanthyl $\text{C}^7\text{H}^{13} - \text{C} = \text{C}^6\text{H}^{13}$, Hexyl.

These metamorphoses, which are theoretically possible, are, to a considerable extent, also practically possible. See *Radical Theory of Chemistry*, page 76. I cannot go into details here. Suffice it to say, that enough of these changes have been effected to prove that all the radicals of this series may be safely considered to consist of multiples of CH^2 , characterised in the case of the basic radicals by the addition of H, and in that of the acid radicals by the addition of CH , and that these radicals are capable of reduction from the acid state to the basic state, and *vice versa*, by the employment of suitable chemical agencies. Of these transmutations many examples will be cited in the following pages.

GROUP A. *Basic Radicals of the Vinyl series.*

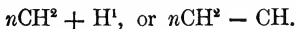

- 1^k. $\text{C}^1 \text{H}^3$. Methyl. The basic radical of wood spirit.
Wood spirit = $\text{H}, \text{CH}^3\text{O}$. Marsh gas = H, CH^3 .
 - 2^k. $\text{C}^2 \text{H}^5$. Ethyl. The radical of ether and alcohol.
Alcohol = $\text{H}, \text{C}^2\text{H}^5\text{O}$. Ether = $\text{C}^2\text{H}^5, \text{C}^2\text{H}^5\text{O}$.
 - 3^k. $\text{C}^3 \text{H}^7$. Propyl. Propylic alcohol = $\text{H}, \text{C}^3\text{H}^7\text{O}$.
 - 4^k. $\text{C}^4 \text{H}^9$. Butyl (tetryl, or valyl). Butylic alcohol = $\text{H}, \text{C}^4\text{H}^9\text{O}$.
Produced by the electrolysis of valerianate of potash.
 - 5^k. $\text{C}^5 \text{H}^{11}$. Amyl. The radical of fusel oil, potato spirit, or amylic alcohol, the formula of which is = $\text{H}, \text{C}^5\text{H}^{11}\text{O}$.
 - 6^k. $\text{C}^6 \text{H}^{13}$. Hexyl (Caproyl). Caproic alcohol = $\text{H}, \text{C}^6\text{H}^{13}\text{O}$.
Procured by decomposing oenanthylic acid (No. 37).
 - 7^k. $\text{C}^7 \text{H}^{15}$. Heptyl. Castor-oil alcohol = $\text{H}, \text{C}^7\text{H}^{15}\text{O}$.
 - 8^k. $\text{C}^8 \text{H}^{17}$. Octyl. Caprylic alcohol = $\text{H}, \text{C}^8\text{H}^{17}\text{O}$.
 9. $\text{C}^9 \text{H}^{19}$. Unknown.
 10. $\text{C}^{10}\text{H}^{21}$. Unknown.
 - 11^k. $\text{C}^{11}\text{H}^{23}$. Un-named. Present in Laurone = $\text{C}^{11}\text{H}^{23}, \text{C}^{12}\text{H}^{23}\text{O}^2$.
The acid radical $\text{C}^{12}\text{H}^{23}$ is Lauryl, No. 42.
 12. $\text{C}^{12}\text{H}^{25}$. Unknown.
 - 13^k. $\text{C}^{13}\text{H}^{27}$. Un-named. In Myristone = $\text{C}^{13}\text{H}^{27}, \text{C}^{14}\text{H}^{27}\text{O}^2$.
The acid radical $\text{C}^{14}\text{H}^{27}$ is Myristyl, No. 44.
 14. $\text{C}^{14}\text{H}^{29}$. Unknown.
 - 15^k. $\text{C}^{15}\text{H}^{31}$. Un-named. In Palmitone = $\text{C}^{15}\text{H}^{31}, \text{C}^{16}\text{H}^{31}\text{O}^2$.
The acid radical $\text{C}^{16}\text{H}^{31}$ is Palmityl, No. 46.
 - 16^k. $\text{C}^{16}\text{H}^{33}$. Cetyl. In ethal = $\text{H}, \text{C}^{16}\text{H}^{33}\text{O}$.
Bisulphate of Cetyl = $\text{H}, \text{C}^{16}\text{H}^{33}; 2\text{SO}^2$.
 17. $\text{C}^{17}\text{H}^{35}$
 18. $\text{C}^{18}\text{H}^{37}$
 19. $\text{C}^{19}\text{H}^{39}$
 20. $\text{C}^{20}\text{H}^{41}$
 21. $\text{C}^{21}\text{H}^{43}$
 22. $\text{C}^{22}\text{H}^{45}$
 23. $\text{C}^{23}\text{H}^{47}$
 24. $\text{C}^{24}\text{H}^{49}$
 25. $\text{C}^{25}\text{H}^{51}$
 26. $\text{C}^{26}\text{H}^{53}$
- } Unknown.
- 27^k. $\text{C}^{27}\text{H}^{55}$. Ceryl. Hydrate of Ceryl = $\text{H}, \text{C}^{27}\text{H}^{55}\text{O}$.

28. $C^{28}H^{57}$ }
 29. $C^{29}H^{59}$ } Unknown.
 30^k. $C^{30}H^{61}$. Myricyl. Hydrate of Myricyl = $H, C^{30}H^{61}O$.
 Palmitate of Myricyl = $C^{30}H^{61}, C^{16}H^{31}O^2$.

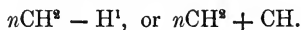
GROUP B. *Acid Radicals of the Vinyl series.*

- 31^k. C^1H . Formyl. The acid radical of the Formiates.
 Formic acid = H, CHO^3 . Pyrogallic acid = CH, CHO .
- 32^k. C^2H^3 . Acetyl. The radical of the Acetates.
 Acetic acid = $H, C^2H^3O^2$.
 C^2H^3 . The radical of Glycollic acid = $H, C^2H^3O^3$.
 The amidogen salt of this acid = $NH^2, C^2H^3O^2$ is called
 Glycoll. Perhaps the radical C^2H^3 is the same both
 in acetic acid and glycollic acid, and the difference
 between the two acids is only that of the degree of
 oxidation. However, the constitution of glycollic acid
 is not yet thoroughly established.
- C^3H^5 . Myl. See Citric acid, GROUP D.
- 33^k. C^3H^5 . Propionyl. The radical of the Propionates.
 Propionic acid = $H, C^3H^5O^2$.
 C^3H^5 . Glycyl. In terbasic Glycerine = $H^3, C^3H^5O^3$.
 C^3H^5 . Allyl. In allylic acid = $H, C^3H^5O^2$.
 C^3H^5 . Lactyl. In lactic acid = $H, C^3H^5O^2$.
- 34^k. C^4H^7 . Butyryl. The radical of the Butyrates.
 Butyric acid = $H, C^4H^7O^2$.
- 35^k. C^5H^9 . Valeryl. The radical of the Valerianates.
 Valerianic acid = $H, C^5H^9O^2$.
- 36^k. C^6H^{11} . Caproyl. The radical of the Caproates.
 Caproic acid = $H, C^6H^{11}O^2$.
 C^6H^{11} . Leucyl. The radical of leucic acid = $H, C^6H^{11}O^3$.
 Leucine is the amidogen salt of this acid $NH^2, C^6H^{11}O^2$.
- 37^k. C^7H^{13} . Oenanthyl. The radical of the Oenanthylates.
 Oenanthylic acid = $H, C^7H^{13}O^2$. Oenanthol = $H, C^7H^{13}O$.
 Derived from the destructive distillation of castor oil.
- 38^k. C^8H^{15} . Capryl. The radical of the Caprylates.
 Caprylic acid = $H, C^8H^{15}O^2$.
- 39^k. C^9H^{17} . Pelargyl. The radical of the Pelargonates.
 Pelargonic acid = $H, C^9H^{17}O^2$.
- 40^k. $C^{10}H^{19}$. Rutil. The radical of the Rutates.
 Rutil (or Capric) acid = $H, C^{10}H^{19}O^2$.
- 41^k. $C^{11}H^{21}$. Margarityl. The radical of the Margaritates.
 Margaritic acid = $H, C^{11}H^{21}O^2$.
 $C^{11}H^{21}$. Enodyl. Enodic aldehyd = $H, C^{11}H^{21}O$, from oil of rue.

- 42^k. C¹⁸H²³. Lauryl. The radical of the Laurates.
Lauric acid = H,C¹⁸H²³O².
- 43^k. C¹³H²⁵. Cocinyl. The radical of the Cocinates.
Cocinic acid = H,C¹³H²⁵O².
- 44^k. C¹⁴H²⁷. Myristyl. The radical of the Myristates.
Myristic acid = H,C¹⁴H²⁷O².
- 45^k. C¹⁵H²⁹. Benyl. The radical of the Benates.
Benic acid = H,C¹⁵H²⁹O².
- 46^k. C¹⁶H³¹. Palmityl. The radical of the Palmitates.
Palmitic acid = H,C¹⁶H³¹O².
- 47^k. C¹⁷H³³. Margaryl. The radical of the Margarates.
Margaric acid = H,C¹⁷H³³O².
- 48^k. C¹⁸H³⁵. Stearyl. The radical of the Stearates.
Stearic acid = H,C¹⁸H³⁵O².
- 49^k. C¹⁹H³⁷. Balenyl. The radical of the Balenates.
Balenic acid = H,C¹⁹H³⁷O².
- 50^k. C²⁰H³⁹. Butynyl. The radical of the Butynates.
Butynic acid = H,C²⁰H³⁹O².
- 51^k. C²¹H⁴¹. Behenyl. The radical of the Behenates.
Behenic acid = H,C²¹H⁴¹O².
- | | | | |
|---|---|-------------------------------------|------------|
| 52. C ²² H ⁴³ | } | 55. C ²⁵ H ⁴⁹ | } Unknown. |
| 53. C ²³ H ⁴⁵ | | 56. C ²⁶ H ⁵¹ | |
| 54. C ²⁴ H ⁴⁷ | | | |
| 57 ^k . C ²⁷ H ⁵³ | | | |
- 57^k. C²⁷H⁵³. Cerotyl. The radical of the Cerotates.
Cerotic acid = H,C²⁷H⁵³O².
- | | | |
|-------------------------------------|---|------------|
| 58. C ²⁸ H ⁵⁵ | } | } Unknown. |
| 59. C ²⁹ H ⁵⁷ | | |
- 60^k. C³⁰H⁵⁹. Melissyl. The radical of the Melissates.
Melissic acid = H,C³⁰H⁵⁹O².

GROUP C. *Acid Radicals of the Succinic series.*

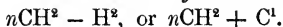

This is a regular though short series of acid radicals, which we may conceive to be formed by commencing with a single atom of carbon = C¹, and adding to it, one by one, a succession of atoms of vinyl, each = C¹H². We thus produce a series of acid radicals, which are all distinguished from those of the vinyl series by having an even number of atoms of hydrogen. The primary radical C, and its first compound C²H², have both the peculiarity of losing their atomic measure when they form gaseous salts. The other members of the series do not produce gases. All the salts of this series take two atoms of oxygen, except the tartrates.

- 61^k. C¹. Carbon. The acid radicals of the Oxalates and Carbonates.
Oxalic acid = H,CO². Carbonate of potash = KK,CO³.

- 62^k. C² H². Succinyl. The radical of the Succinates.
Succinic acid = H, C² H² O².
- C² H². Tartryl. The radical of the Tartrates.
Tartaric acid = H, C² H² O².
- 63^k. C³ H⁴. Adipyl. The radical of the Adipates.
Adipic acid = H, C³ H⁴ O².
- 64^k. C⁴ H⁶. Suberyl. The radical of the Suberates.
Suberic acid = H, C⁴ H⁶ O².
- 65^k. C⁵ H⁸. Sebamyl. The radical of the Sebrates.
Sebacic acid = H, C⁵ H⁸ O².

The salts of this series combine with one another, and produce double salts, which have hitherto been considered as bibasic salts with single acid radicals. Thus:—

Pyrotartaric acid HH, C ³ H ⁶ O ⁴	} contains	{ Succinic acid = H, C ² H ² O ²
Pimelic acid HH, C ⁷ H ¹⁰ O ⁴	} contains	{ Adipic acid = H, C ³ H ⁴ O ²
Anchoic acid HH, C ⁹ H ¹⁴ O ⁴	} contains	{ Suberic acid = H, C ⁴ H ⁶ O ²
		{ Sebacic acid = H, C ⁵ H ⁸ O ²

According to the radical theory, the assumed bibasic radicals C⁵ H⁸, C⁷ H¹⁰, and C⁹ H¹⁴ do not exist; but the salts called pyrotartrates, pimelates, and anchoates are all double salts, each containing two acid radicals of the succinic series. The evidence in support of this view is given at length in my treatise on the Radical Theory.

GROUP D. $n\text{CH}^2 - \text{H}^3$.

The radicals of this series appear to be nearly all produced or separated by the application of heat to substances that belong to the vinyl series (Groups A and B), and their relation to the radicals of that series is easily perceived. Thus:—

Glycyl (Allyl)	= C ³ H ³ - H ² = C ³ H ³	Acryl.
Stearyl	= C ¹⁸ H ³⁵ - H ² = C ¹⁸ H ³³	Oleyl.
Oleyl	= C ¹⁸ H ³³ - C ¹ = C ¹⁷ H ³³	Margaryl.
Acetyl	= C ² H ³ - H ² = C ² H ¹	Fumaryl.

In short, all the radicals of this group may be considered to be convertible into acid radicals of the vinyl series, Group B, by the addition of H², or the subtraction of C¹. Probably they all exist in the living plant or animal as members of the vinyl series, and owe the forms in which they are shown in the following list to the metamorphoses effected by the chemical reactions that are employed to separate them from other substances. They are all monobasic, and must, therefore, be considered as single radicals.

- 66^k. C²H . Maleyl. In Maleic acid = H,C²HO².
 Fumaryl. In Fumaric acid = H,C²HO².
 Aconyl. In Aconitic acid = H,C²HO².
 Dyl. See Citric acid (*below*).
- 67^k. C³H³. Acryl. In Acrylic acid = H,C³H³O².
 Present in Acrolein = H,C³H³O. Produced by the distillation of Glycerine.
 Pyruvyl. In Pyruvic acid = H,C³H³O³.
 Tryl. See Citraconic acid (*below*).
- 68^k. C⁴H⁵. The radical of Isotartaric acid = H,C⁴H⁵O⁶?
- 69^k. C⁵H⁷. The radical of Camphoric acid = H,C⁵H⁷O².
 C⁵H⁷. The radical of Angelic acid = H,C⁵H⁷O², obtained from angelica root.
 The essence of Camomile is its aldehyd = H,C⁵H⁷O.
70. C⁶H⁹. }
 71. C⁷H¹¹. } Unknown.
- 72^k. C⁸H¹³. Conyl. Conia or Conine = NH,C⁸H¹³; H.
73. C⁹H¹⁵. Unknown.
- 74^k. C¹⁰H¹⁷. Camphyl. In Campholic acid = H,C¹⁰H¹⁷O².
75. C¹¹H¹⁹ |
 76. C¹²H²¹ | 77. C¹³H²³ }
 78. C¹⁴H²⁵ } Unknown.
- 79^k. C¹⁵H²⁷. The radical of Moringic acid = H,C¹⁵H²⁷O², derived from oil of ben (the basis of Macassar oil).
- 80^k. C¹⁶H²⁹. The radical of Hypogeic acid = H,C¹⁶H²⁹O², derived from sperm oil.
81. C¹⁷H³¹. Unknown.
- 82^k. C¹⁸H³³. Oleyl. The radical of Oleic acid = H,C¹⁸H³³O², derived from the non-drying oils.
- 83^k. C¹⁹H³⁵. The radical of Doeglinic acid = H,C¹⁹H³⁵O².
 From the oil of the *Balæna rostrata*, a sperm whale, which oil contains no glycerine.
84. C²⁰H³⁷. }
 85. C²¹H³⁹. } Unknown.
- 86^k. C²²H⁴¹. The radical of Erucic acid = H,C²²H⁴¹O², derived from the oil of mustard or rape (colza oil).

Compound Acids derived from this series.

CITRIC ACID = H³,C⁶H⁵O⁷, a tribasic acid, in which H³ are replaceable by other basic radicals, such as M³, or M²H¹, or M¹H². I consider this acid to be a triple salt, composed as follows:—

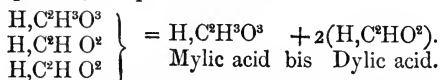

The radical C²H³ may be acetyl or some other having the same com

position. I call it provisionally Myl. The formula which I have given to mylic acid agrees with that of glycollic acid. See No. 33. The radical C^2H is equal in composition to aconyl, fumaryl, and maleyl (see No. 66), and it may be one of these, but not to prejudge the question I call it Dyl. The evidence upon which this view of the triplicate nature of citric acid is founded is given in my work on the Radical Theory, page 424.

MALIC ACID = $H^2, C^4H^4O^5$, a bibasic acid in which H^2 are replaceable by other basic radicals, such as M^2 and M^1H^1 . I consider malic acid to be a double acid, composed as follows:—

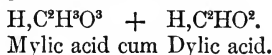

The radicals Myl = C^2H^3 , and Dyl = C^2H , are probably the same as the corresponding radicals ascribed to the citrates.

CITRACONIC ACID = $H^2, C^5H^4O^4$. A bibasic acid in which H^2 are replaceable by other basic radicals. This acid appears to me to be a double acid composed as follows:—

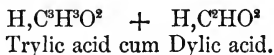

The radical C^3H^3 may possibly be acryl or pyruvyl—see No. 67—but I cannot determine the point, and in the meantime I call it Tryl.

GALLIC ACID = $H^3, C^7H^6O^6$. Usually assumed to be a tribasic acid, in which H^3 is replaceable by other basic radicals. This may possibly be a triple salt, constituted thus:—

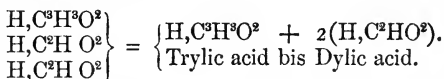

According to this view of the constitution of the vegetable acids, none of them are bibasic, or tribasic, or polybasic in any sense; but all of them are double or triple compounds of monobasic acids, containing radicals of very simple constitution, such as C^2H , C^2H^3 , and C^3H^3 . The acids formed by these radicals, combine with each other into pairs, or triads, but lose none of their chemical power, and while in a normal state lose none of their oxygen. Each retains its full power of saturation, and, though held in combination, acts as if it were isolated; the reason being, that for every atom of replaceable hydrogen, that is to say, for every basic radical that is present in a compound acid there is also present an acid radical to neutralise it. The evidence in support of this view of the constitution of polybasic acids is given in detail in my work on the Radical Theory. It is too copious to be introduced here. But in the subsequent special description of the acids I shall show that this general view of their constitution is perfectly consistent with their properties and reactions.

GROUP E. $n\text{CH}^2 - \text{H}^4$.

The radicals usually grouped under this head are, with the exception of the starting radical C^2 , all double radicals, or acid radicals of double salts. They do not exist as bibasic radicals. Compare this group with groups C. and D.

- | | | | |
|-------------------|-----------------------------|--|------------|
| 87 ^k . | C^2 . | The radical of mellitic acid = $\text{H}, \text{C}^2\text{O}^2$. | |
| 88. | C^3H^2 . | Unknown. | |
| 89. | C^4H^4 . | See Malic acid = $\text{H}^2, \text{C}^4\text{H}^4 \text{O}^5$. | GROUP D. |
| 90. | C^5H^6 . | See Pyrotartaric acid = $\text{H}^2, \text{C}^5\text{H}^6 \text{O}^4$ | |
| 91. | C^6H^8 . | See Adipic acid = $\text{H}, \text{C}^6\text{H}^8 \text{O}^2$ | } GROUP C. |
| 92. | C^7H^{10} . | See Pimelic acid = $\text{H}^2, \text{C}^7\text{H}^{10}\text{O}^4$ | |
| 93. | C^8H^{12} . | Unknown. $\text{C}^8\text{H}^{12} \div 2 = \text{C}^4\text{H}^6$. Suberyl | |
| 94. | C^9H^{14} . | See Anchoic acid = $\text{H}^2, \text{C}^9\text{H}^{14}\text{O}^4$ | |

GROUP F. $n\text{CH}^2 - \text{H}^5$.

- | | | |
|-------------------|--------------------------|--|
| 95. | C^3H^1 . | Unknown. |
| 95 ^k . | C^6H^7 . | Sorbyl. The radical of Sorbic acid = $\text{H}, \text{C}^6\text{H}^7\text{O}^2$.
From the berries of the mountain ash. |

GROUP G. $n\text{CH}^2 - \text{H}^6$.

- | | | |
|-------------------|--------------------------|---|
| 96 ^k . | C^8 . | The acid radical of the mesoxalates, a class of salts which seem to have been insufficiently examined. Some of their formulæ are as follow:—
$\text{H}^2, \text{C}^8\text{O}^5$; $\text{Pb}^4, \text{C}^8\text{O}^6$; $\text{Ba}^2\text{H}^2, \text{C}^8\text{O}^6$.
These are, no doubt, multiple salts, but it is impossible to give them true formulæ. |
| 97 ^k . | C^4H^2 . | Phtalyl. The radical of phtalic acid = $\text{H}, \text{C}^4\text{H}^2\text{O}^2$. The formula of phtalyl is usually doubled, and it is by that means made to represent a bibasic acid. There is, however, no justification for such a proceeding, unless it could be shown that the phtalic acid is a double acid, such as $(\text{H}, \text{C}^3\text{H}^3\text{O}^2 + \text{H}, \text{C}^5\text{HO}^2)$. |
| 98. | C^5H^4 . | The radical of citraconic acid, which I have explained under GROUP D, as a double acid. |

GROUP H. $n\text{CH}^2 - \text{H}^7$.

- | | | |
|--------------------|--------------------------|--|
| 99. | C^4H^1 . | See No. 132, GROUP P. |
| 100 ^k . | C^5H^3 . | The radical of pyromeconic acid. See No. 125. GROUP O. |
| 101 ^k . | C^6H^5 . | Phenyl. An important radical which occurs in Aniline, Benzole, &c. |
| | C^6H^5 . | Citryl. The assumed radical of the tribasic citric acid. I believe that no such radical exists in the citrates, but that they are triple salts, each containing not only three basic radicals, but also three acid radicals. See page 405. |

- 102^k. C⁷ H⁷. Toluenyl. In balsam of tolu.
 103^k. C⁸ H⁹. Xylenyl. In the oils from wood spirit.
 104^k. C⁹ H¹¹. Cumenyl. In cumole = H, C⁹ H¹¹.
 105^k. C¹⁰ H¹³. Thymyl. From oil of thyme.

These five radicals are all of the basic order, and act in salts the part of basic radicals without requiring any oxygen beyond that which is proper to the normal salts of the acid radicals with which they combine.

In tracing the homology of this group of radicals, from the most complex to the most simple in the series, throwing out CH² at each step, we come at last to the radical C⁴ H¹, which does not belong to the vinyl series. I have endeavoured to account for the origin of this radical in GROUP P, where I suppose that a series of radicals are produced by the successive combination of atoms of C with one atom of H, acting as the primary nucleus. The radicals of GROUP H belong to the series of Essential Oils, which are produced by Nature in fruits, seeds, &c., under circumstances where not only oxygen but water itself could be given off during the conversion of sugar into the oils demanded by the wants of the living plant. In that way atoms of carbon could be added to salts of the vinyl series till the composition demanded by the plant was completed, though it is impossible to form a clear idea of the manner in which this operation takes place.

The artificial formation of some of these radicals takes place in accordance with facts which it is easy to recognize. Thus, Phenyl = C⁶ H⁵, is derived from Indyl = C⁸ H³ (No. 126, GROUP O) by chemical means which remove C² and add H². This double action renders the process complex, but the metamorphoses of radicals by the removal or the addition of atoms of C or of H, is very common.

GROUP I. $n\text{CH}^2 - \text{H}^8$.

106. C⁴ H⁰; C⁵ H²; C⁶ H⁴. No radicals of this series and no salts of such radicals are known. In fact, if found, they would be double salts of former groups.

GROUP K. $n\text{CH}^2 - \text{H}^9$.

107. C⁵ H¹ }
 108. C⁶ H³ } Unknown.
 109^k. C⁷ H⁵. Benzyl. The radical of the Benzoates.
 Benzoic acid = H, C⁷ H⁵ O².
 C⁷ H⁵. Spiryl. The radical of the Salicylites. Salicylous acid the essential oil of the flowers of the meadow sweet (*Spiræa ulmaria*) = H, C⁷ H⁵ O². This radical must not be confounded with that of the Salicylates. See No. 116, GROUP L.
 110^k. C⁸ H⁷. Toluyl. The radical of the Toluates.
 Toluic acid = H, C⁸ H⁷ O².

- $C^8 H^7$. Anisyl. The radical of the Anisates.
 Anisic acid = $H, C^8 H^7 O^3$.
- 111^k. $C^9 H^9$. Styryl. The radical of Styrene = $H, C^9 H^9 O$.
 Derived from the gum resin called Storax.
- 112^k. $C^{10} H^{11}$. Cumyl. The radical of the Cuminates.
 Cuminic acid = $H, C^{10} H^{11} O^2$.
113. $C^{11} H^{13}$. Unknown.

The radicals of GROUP K belong to the resinous or aromatic series, and are nearly related to those of GROUP H, both in properties and in composition, and their origin is probably liable to a similar explanation. On bringing into comparison those radicals of the two groups which have the same quantity of carbon, we perceive that owing to the difference in their hydrogen, they bear to one another, in pairs, the relations of basic radicals to acid radicals, the common difference, like that between the two orders of vinyl radicals, being H^2 . Thus,

Phenyl	$C^6 H^5 - H^2 = C^6 H^3$, Unknown
Toluenyl	$C^7 H^7 - H^2 = C^7 H^5$, Benzyl
Xylenyl	$C^8 H^9 - H^2 = C^8 H^7$, Toluyyl (and Anisyl)
Cumenyl	$C^9 H^{11} - H^2 = C^9 H^9$, Styryl
Thymyl	$C^{10} H^{13} - H^2 = C^{10} H^{11}$, Cumyl;

or, changing the expression of the relation in *terms*, though not in *essence*, we have

Phenyl	$C^6 H^5 + C^1 = C^7 H^5$, Benzyl
Toluenyl	$C^7 H^7 + C^1 = C^8 H^7$, Toluyyl
Xylenyl	$C^8 H^9 + C^1 = C^9 H^9$, Styryl
Cumenyl	$C^9 H^{11} + C^1 = C^{10} H^{11}$, Cumyl
Thymyl	$C^{10} H^{13} + C^1 = C^{11} H^{13}$, Unknown.

And in effect these figures accurately express the corresponding chemical powers of the respective radicals; for those of GROUP H are basic while those of GROUP K are acid. Those of GROUP H go into salts as basic radicals without carrying additional oxygen with them; but those of GROUP K, when they act as basic radicals, demand an additional supply of oxygen, and that quantity differing according to the acid properties of each special radical: Thus, toluyyl, which forms toluates with O^2 takes with it O^1 extra when it acts as a basic radical; while anisyl, which forms anisates with O^3 , takes with it O^2 extra when it acts the part of a basic radical. These details afford interesting illustrations of the truth of the general principle which I have advanced, namely, that the difference which exists between organic basic and acid radicals is expressed either by C^1 or H^2 , since these proportions of carbon or of hydrogen are sufficient to change the class of any radical, whatever may be its ultimate composition. The question of basicity or acidity never depends upon the *absolute quantity* of carbon or hydrogen that happens to be present in any radical, but entirely upon the *relative proportions* of those elements.

GROUP L. $n\text{CH}^2 - \text{H}^{10}$.

114. C^5H^0 . Unknown.
 115^k. C^6H^2 . The radical of the Comenates. See note to GROUP O.
 116^k. C^7H^4 . Salicyl. The radical of the Salicylates.
 Salicylic acid = H,H ; $\text{C}^7\text{H}^4\text{O}^3$.

The Salicylates appear to me to be formed on the model of the Carbonates, and they are consequently BIBASIC in the same sense that the carbonates are bibasic. Thus :

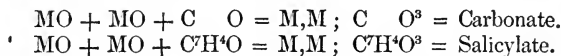

There is no known salt which bears to the salicylates the relation that the oxalates bear to the carbonates, namely, a salt of the formula $\text{MO} + \text{C}^7\text{H}^4\text{O} = \text{M},\text{C}^7\text{H}^4\text{O}^2$. The salts that are now called salicylites have the formula $\text{M},\text{C}^7\text{H}^5\text{O}^2$, which resembles that of the benzoates. They are monobasic, and the radical C^7H^5 does not belong to the salicylic group. I propose to call that radical spiryl. Then, salicylous acid, or the hydride of salicyl, the essential oil prepared from the flowers of the meadow-sweet (*Spiræa ulmaria*), will be $\text{H},\text{C}^7\text{H}^5\text{O}^2 = \text{Hydra spirylete}$. See No. 109, GROUP K.

It is possible that salicyl = C^7H^4 , may be hereafter discovered to be a double radical; but I have at present no evidence of such a discovery, and therefore I admit it to be a single radical, having the power to produce salts with two basic radicals, in the manner of the carbonates.

For a detailed account of the salicylates, see "The Radical Theory in Chemistry," page 455.

GROUP M. $n\text{CH}^2 - \text{H}^{11}$.

117. C^6H^1 .
 118. C^7H^3 .
 119. C^8H^5 .
 120^k. C^9H^7 . } Unknown.
 Cinnamyl. The radical of the Cinnamates.
 Cinnamic acid = $\text{H},\text{C}^9\text{H}^7\text{O}^2$. When cinnamyl acts as a basic radical, it takes O^1 extra.

GROUP N. $n\text{CH}^2 - \text{H}^{12}$.

121. C^6H^0 . Unknown.
 122^k. C^9H^6 . The radical of Insolinic acid.
 123. C^{10}H^8 . Unknown.
 124^k. $\text{C}^{11}\text{H}^{10}$. The radical of Sinapic acid.

The formula C^9H^6 represents the radical of Hoffmann's recently discovered bibasic insolinic acid = $\text{HH},\text{C}^9\text{H}^6\text{O}^4$. When this acid is distilled, it yields benzoic acid. This reaction, with the composition of the formula, its bibasic nature, its double quantity of oxygen, and

the even number of its atoms of hydrogen, all concur to induce me to consider the insolinic acid to be a double acid, probably composed of

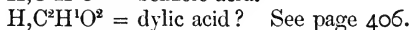
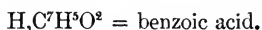

The other formula of this group $\text{C}^{11}\text{H}^{10}$ represents the radical of sinapic acid, $\text{H}^2\text{C}^{11}\text{H}^{10}\text{O}^5$, a bibasic acid, the existence of which is rather suppositional than proved. It is probably a double salt.

A comparison of the radicals of groups C, E, I, and N, shows it to be extremely probable, that none but monobasic acids belong to any of them, and that the apparently bibasic salts are in all cases double salts, whose acid radicals require discrimination.

GROUP O. $n\text{CH}^2 - \text{H}^3$.

125^k. C^7H^1 . The radical of the Meconic acid.

126^k. C^8H^3 . Indyl. The radical of Indigo. Constitution of indigo white = $\text{NH}^4, \text{C}^8\text{H}^3\text{O} + \text{NH}^2, \text{C}^8\text{H}^3\text{O}$. Constitution of indigo blue = $\text{NH}^2; \text{C}^8\text{H}^3\text{O}$. A complete investigation of the compounds of indigo will be found at page 257 in the "Radical Theory in Chemistry."

127. C^9H^5 . Unknown.

128^k. C^{10}H^7 . Naphtyl. The radical of Naphthaline = $\text{H,C}^{10}\text{H}^7$.

The known radicals of GROUP O are as follow:—

C^7H^1 is the radical of the meconic acid, which is assumed to be tribasic, but I cannot say that this tribasic character rests upon satisfactory grounds. The meconates are $\text{IHH,C}^7\text{H}^1\text{O}^7$. When heated, they give off CO^2 and becomes comenates = $\text{HH,C}^6\text{H}^2\text{O}^5$. See No. 115, GROUP L. When the comenates are heated, they give off CO^2 , and becomes pyromeconates = $\text{H,C}^5\text{H}^3\text{O}^3$. See No. 100, GROUP H. Thus, throughout the series, the acid radical contains in all 8 atoms. When C^1 goes off, H^1 comes to replace it. This proceeding is repeated. The H^1 which thus replaces the disengaged C^1 is a basic radical; and as the change proceeds in the acid radical, the acid radical of the salt, which first is tribasic, changes to bibasic, and then to monobasic. I expect that we shall by-and-by have a very different account of these metamorphoses.

C^8H^3 is the formula of indyl, which radical is, like meconyl, liable to undergo two remarkable changes, without diminution of the collective number of its ultimate atoms. Thus:—

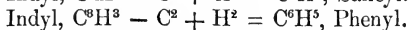
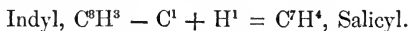

I wish I could understand or explain the nature of these changes.

The last formula of this group is $\text{C}^{10}\text{H}^7 = \text{naphtyl}$, a radical which, like phenyl, is singularly addicted to form part of amidogens and

ammoniums, and thus give origin to numerous complicated multiple salts.

GROUP P. $nC + H$, or $nC + CH$.

129. C^1H^1	132. C^4H^1	134. C^6H^1
130. C^2H^1	133. C^5H^1	135. C^7H^1 .
131. C^3H^1		

This group, purely hypothetical, is inserted to account for the starting radicals in the groups D, F, H, K, M, O. I suppose that originally C^1 combines with H^1 or with C^1H^1 , and that C^1 is then assumed atom after atom, till the several products which are exhibited in this column are produced; after which these radicals, acting as units, combine with successive atoms of CH^2 to produce the radicals which form the groups given in the different columns of the Table.

It is, however, just as easy to imagine that the radicals are first formed in accordance with the methods of production explained in reference to the vinyl radicals, and that these radicals then become subject to the successive additions of atoms of C^1 . Or, on the other hand, some of them may be explained as being derived from radicals actually belonging to the vinyl series, by the artificial expulsion of a limited quantity of hydrogen. Thus terbasic glycerine = $H, H, H, C^3H^3O^3$ when deprived of HHO produces monobasic allylic acid = $H, C^3H^3O^2$, and when deprived of a second atom of HHO , it produces acrolein = H, C^3H^3O , in which we have an acid radical belonging to Group D. This last reaction differs in no respect or degree, as respects the change in the radicals, from that which converts alcohol into aldehyd:—

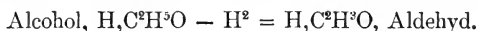

It is unquestionably a fact that the basic radicals are reducible to acid radicals by the abstraction of H^2 , and it does not seem unreasonable to assume that the acid radicals themselves may be capable of sustaining successive abstractions of H^2 , by artificial means, so as to produce the more highly carbonised radicals. Thus C^5H^{11} may become in succession $C^5H^9, C^5H^7, C^5H^5, C^5H^3$; and in like manner C^9H^{19} , may become $C^9H^{17}, C^9H^{15}, C^9H^{13}, C^9H^{11}, C^9H^9, C^9H^7, C^9H^5$. These are points that are capable of experimental investigation, and are not likely to pass unheeded.

Besides these groups of radicals, I have endeavoured to trace the existence of others, but without useful results. For example, the Group $nC + CH^2$ produces C^4H^2 and C^6H^2 , but no other known radicals; and the Group $C + nH$ produces CH, CH^2, CH^3 , and then stops, as there is no known hydrocarbon radical with a greater proportion of H to C than is found in methyl.

On looking over these homologous groups of radicals, the remarkable fact strikes us, that the greater proportion of them are produced by a very direct process from sugar or vinylate, and that most of the others

seem to be derived by processes, which, though indirect, are short and obvious, from the same substance. Sugar in the form of $\text{CH}^{\circ}\text{O}$ is the raw material which life in plants works up into the innumerable finished manufactures which vegetables expose to the admiration of mankind and among which animal life finds sustenance.

CONSTITUTION OF VICE-RADICALS.

The compound radicals which have been arranged in the Table between pages 400 and 412 are subject, under the peculiar action of various reagents, to have part, or even the whole, of their hydrogen replaced by other radicals, so as to produce an entirely new series of radicals, retaining to a certain extent the properties, basic or acid, of the original radicals, but not acting in compounds with the same degree of vigour as the original radicals that have not undergone this process of substitution. I propose to give such altered radicals the name of *Vice-radicals*. There are five principal varieties.

1. *Chloric radicals*: in which a certain number of atoms of hydrogen are replaced by chlorine. Bromine and iodine act in the same manner.

2. *Nitrogen radicals*; in which the hydrogen is replaced by nitrogen; but in this case, every atom of replacing nitrogen carries into the salt two atoms of additional oxygen.

3. *Sulphuric radicals*. When atoms of hydrogen are replaced by atoms of sulphur, each atom of sulphur carries with it one additional atom of oxygen.

4. *Metallic Vice-radicals*. Amidogen = NH° , and ammonium = NH^{H} , can have part, on the whole of their hydrogen replaced by metallic radicals, without destruction to the form or properties of the amidogen or ammonium.

The hydrocarbon radicals can also permit some of their hydrogen to be replaced by metals when acting as basic radicals. This point has not hitherto had much consideration bestowed upon it, but the fact is susceptible of experimental demonstration.

5. Amidogen = NH° , and ammonium = NH^{H} , are further subject to form many vice-radicals, by the substitution of various compound radicals for some or all of their hydrogen.

I have shown elsewhere ("Radical Theory in Chemistry," p. 94) that the systematic nomenclature recommended in this work can be easily extended to such compounds.

THE SALTS PRODUCED BY ORGANIC RADICALS.

From the radicals enumerated in the foregoing Table, and from other similar radicals, still unknown to us, spring, by combination with one another, with oxygen, and with inorganic radicals, that infinite variety of salts, of which plants and animals are composed, or which appear to us among the products of their decomposition.

As to such salts, it will not be expected or desired that I should, in this place, go into much detail. I am not writing a *system* of organic chemistry, but drawing a *sketch* of its prominent features; and I must content myself, and I hope the reader also, by giving a few brief notices of the chief GROUPS or SERIES into which organic salts are arranged, and by restricting details to a few SELECT SALTS, which may serve as illustrative examples of the various forms of organic combination.

I. ORGANIC SALTS IN GROUPS OR SERIES.

The reader is requested to bear in mind the signification of the following abridged symbols:—

R^p means a compound radical of the positive or basic series, such as methyl or ethyl.

R^a means a compound radical of the negative or acid series, such as acetyl or benzyl.

A. COMPOUNDS PRODUCED BY BASIC RADICALS.

The salts formed by basic organic radicals have the same general character as those formed by basic inorganic radicals. They fall into oxidised salts and non-oxidised salts. Among the former we find oxides, hydrates, sulphates, nitrates, carbonates, oxalates, cyanates, &c.; and among the latter, chlorides, bromides, iodides, sulphides, cyanides, sulphocyanides, &c. In short, the organic radicals have the same range and completeness of chemical equivalence as the inorganic radicals.

1). H, R^p . *Hydrides or Hydurets of Positive Radicals.*

Compounds which contain one basic radical and one atom of hydrogen. The following are examples:—

H, CH^p . Hydra methyla. Hydride of methyl. Marsh gas.

$H, C^p H^s$. Hydra ethyla. Hydride of ethyl.

$H, C^p H^{11}$. Hydra amyla. Hydride of amyl.

$H, C^p H^5$. Hydra phenyla. Hydride of phenyl. Benzole.

The first names after the formulæ in these lists, are constructed according to the rules of the systematic nomenclature explained at page 132. The names usually applied to the respective substances follow the systematic names. I have introduced these new names to prove the general applicability of the proposed nomenclature.

2). $R^p + R^p$. *Compounds of Basic Radicals with one another.*

The basic radicals combine with one another, and produce compounds which are capable of isolation, and which, when isolated and brought into the gaseous state, show their compound or complex nature by an atomic measure of two volumes. The following are examples:—

C^2H^5, C^5H^{11} .	Ethyla amyla.
C^2H^5, C^4H^9 .	Ethyla butyla.
CH^3, C^6H^{13} .	Methyla hexyla.

These double radicals, like the hydrides of Group I, have the property of containing an even number of atoms of hydrogen; by which they are distinguished from true radicals, most of which contain an odd number of atoms of hydrogen.

3). R^p, R^pO . *Protoxides. Ethers.*

An ether contains two similar basic radicals, one of them combined with one atom of oxygen.

These compounds are similar in constitution to the great class of metallic protoxides, such as quicklime, Ca, CaO . They constitute that variety of ethers of which the model is presented by common ether, frequently called sulphuric ether. The following are examples:—

C^2H^5, C^2H^5O .	Ethyla ethylate.	Ethylic ether (common ether).
CH^3, CH^3O .	Methyla methylate.	Methylic ether.
$C^5H^{11}, C^5H^{11}O$.	Amyla amylate.	Amylic ether.

The term ether is used very vaguely. Sometimes it is given to organic compounds which are not protoxides, but salts containing other radicals, such as chlorides, R^p, Cl , acetates, $R^p, C^2H^5O^2$, and nitrites, R^p, NO^2 .

In like manner the *special* names of ethers are often used vaguely. Thus, the term *sulphuric* ether is sometimes applied to the compound C^2H^5, C^2H^5O , and sometimes to the compound C^2H^5, SO^2 . These cases show the necessity for the adoption of some such exact system of names as that offered by the nomenclature which I have explained at page 132.

4). *Compound Ethers.*

Salts which have the form of the protoxides, 3), but in which the two atoms of R^p are *different*, are called compound ethers. In general, one of the two radicals contains CH^2 , or nCH^2 less than the other. Examples:—

CH^3, C^2H^5O	= Methyla ethylate.
$C^2H^5, C^5H^{11}O$	= Ethyla amylate.
$CH^3, C^5H^{11}O$	= Methyla amylate.

These compound ethers were discovered lately by Professor Williamson.

5). H, R^pO . *Hydrated Oxides. Alcohols.*

An alcohol consists of one basic radical combined with one atom of hydrogen and one atom of oxygen. The alcohols have the same form as the hydrated protoxides of metals, such as caustic potash = KHO .

The principal salt of this series, and the model of the group is common alcohol = H, C^2H^5O . Examples:—

- H, C^1H^3O = hydra methylate. Wood spirit. Pyroxilic spirit.
 H, C^2H^5O = hydra ethylate. Common or vinic alcohol.
 H, C^3H^7O = hydra propylate. Propylic alcohol.
 H, C^4H^9O = hydra butylate. Butylic alcohol.
 $H, C^5H^{11}O$ = hydra amylate. Amylic alcohol, fusel oil, or potato spirit.
 $H, C^6H^{13}O$ = hydra hexylate. Hexylic or caproic alcohol.
 $H, C^8H^{17}O$ = hydra octylate. Octylic or caprylic alcohol.
 $H, C^{12}H^{25}O$ = hydra laurylate. Lauric alcohol.
 $H, C^{16}H^{33}O$ = hydra cetylale. Ethal. Cetylic alcohol.
 $H, C^{27}H^{55}O$ = hydra cerylate. Cerotic alcohol. Cerotin.
 $H, C^{30}H^{61}O$ = hydra myricylate. Hydrate of myricyl. Melissin.

The abstraction of H^2 from an alcohol converts it into an aldehyd. See Group 29). Thus:

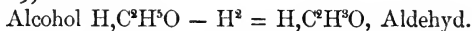

6). R^pCl . *Chlorides*. Examples:—

- C^5H^{11}, Cl . Amyla chlora. Chloride of amyl.
 C^2H^5, Cl . Ethyla chlora. Chloride of ethyl. Chloric ether.
 C^1H^3, Cl . Methyla chlora. Chloride of methyl.

7). R^pI . *Iodides*. Example:—

- C^2H^5, I . Ethyla ioda. Iodide of ethyl.

8). R^pBr . *Bromides*. Example:—

- C^2H^5, Br . Ethyla broma. Bromide of ethyl.

9). R^pS . *Sulphides*. Examples:—

- C^2H^5, S . Ethyla sulpha. Sulphide of ethyl.
 C^3H^7, S . Allyla sulpha. Sulphide of allyl.

This compound is contained in various essential oils, particularly in those of garlic, onions, leeks, cress, radishes, and assafœtida.

10). $R^pS + HS$. *Acid Sulphides*, or compounds of neutral sulphides of Group 9), with sulphide of hydrogen. These compounds have received the name of mercaptans. Examples:—

- $C^2H^5, S + HS$. Ethyla sulpha cum hydra sulpha. Mercaptan, or Ethylo-mercaptan.
 $C^1H^3, S + HS$. Methyla sulpha cum hydra sulpha. Methylomercaptan.

11). R^p, CN . *Cyanides*. Examples:—

- C^1H^3, CN . Methyla cyana. Cyanide of methyl.
 C^5H^{11}, CN . Amyla cyana. Cyanide of amyl.
 C^4H^9, CN . Butyla cyana. Cyanide of butyl.

Some chemists consider these salts to be composed of acid radicals and nitrogen. The question is discussed in my work on the Radical Theory, page 217. See also page 380, and the article Cyanogen, in this work.

12). $R^pS + CyS$, or R^pCyS^2 . *Sulphocyanides*.

The constitution of the sulphocyanides will be explained in the article under that title. The organic sulphocyanides are equivalent to those containing metallic radicals. Examples:—

$C^3H^5, S + CyS$. Allyla sulpha cum cyana sulpha. The sulphocyanide of allyl. The essence of mustard.

13) to 20). R^p , as *Basic Radicals in Oxidised Salts*. These salts are frequently called *Compound Ethers*.

- | | | | | |
|------|----------------------|---|--|--|
| 13). | R^pSO^2 . | <i>Sulphates</i> | } And with most other inorganic acids.
The names sulphate, &c., have here their common signification. | |
| 14). | R^p, R^p, S^2O^3 . | <i>Sulphites</i> | | |
| 15). | R^p, NO^3 . | <i>Nitrates</i> | | |
| 16). | R^p, NO^2 . | <i>Nitrites</i> | | |
| 17). | R^p, CO^2 . | <i>Oxalates</i> | | |
| 18). | $R^p, R^nO^2 =$ | $\left\{ \begin{array}{l} R^p, C^2H^3O^2 \\ R^p, C^7H^5O^2 \end{array} \right.$ | <i>Acetates</i>
<i>Benzotes</i> | } And with nearly all the organic acids. |

Any hydrated acid, whether inorganic or organic, which has a replaceable atom of hydrogen, can exchange that hydrogen, not only for a metallic radical, but for any basic organic radical, and produce a salt agreeing with the general formula No. 18).

19). R^pR^p, CO^3 . *Carbonates*. Examples:—

$C^2H^5, C^2H^5; CO^3$. Ethylen carbite. Carbonic ether.

$CH^3, C^2H^5; CO^3$. Methyla ethyla carbite. Carbonate of ethyl and methyl. Ethyl-methyl-carbonic ether.

$K, C^2H^5; CO^3$. Potassa ethyla carbite. Carbethylate of potash.

These examples show that the carbonates carry out fully their character by producing double basic salts. See page 362. The two basic radicals need not even both belong to one series. In the last example, we have one inorganic and one organic basic radical. It is a practice with some chemists to club together the carbon, the oxygen, and the ethyl, of such a salt, and to call the clump a *conjugated acid*, which it appears to me is treating the carbonates with great injustice.

20). $R^pSO^2 + HSO^2$. *Bisulphates*.

The sulphate of an organic basic radical combines with hydrated sulphuric acid, and produces a double salt, or bisulphate, exactly in the same manner, as does the sulphate of potash, or of any other metallic radical. And just as the bisulphate of potash can exchange its single

atom of replaceable hydrogen for another metallic radical, and so produce a neutral double salt, so can the bisulphate of an organic radical exchange its basic hydrogen for another basic radical, metallic or otherwise, and produce a double neutral sulphate. The parallel between the two kinds of bisulphates seems thus far to be exact; but there is nevertheless a difference between them, which has caused much dispute. The soluble bisulphates of metallic radicals when added to a solution of chloride of barium produce a precipitate of sulphate of barytes. The soluble bisulphates of organic radicals under similar circumstances give no such precipitate. From the observation of this experiment, many chemists have jumped to the conclusion that since the bisulphates of the organic radicals give no precipitate with solutions of barytes, therefore they *are not sulphates at all*, but are salts in which the elements of bisulphates are grouped into proximate constituents which cannot produce a sulphate with a solution of barium. But that conclusion is based upon a weak foundation; for if we consider closely what occurs in the experiment, we find it to be this, that when the organic bisulphate is added to the solution of barium, a double decomposition occurs, and a new double sulphate is produced, containing an organic radical and the barytic radical, as its two basic radicals, $C^2H^5,SO^2 + Ba,SO^2$, but which double sulphate has, *per se*, the property of being soluble in the liquor in which it is produced, from which, therefore, it cannot precipitate. True it is, that sulphate of barytes, not combined with an organic sulphate, is insoluble in most liquors. True, also, it seems to be, that sulphate of barytes, combined with an organic sulphate, is soluble in almost every liquor. Why, then, are we to jump to the conclusion, that because it is soluble it is not a sulphate? We see the reason why it is soluble. Why are we to dispute the facts and declare that because it is soluble it is not a sulphate? The practice of chemists in this matter is unphilosophical. Nature has ordained that sulphate of barytes, when present in inorganic solutions, shall be insoluble. Her law is inflexible, and chemists learn and obey it. But the same Nature has ordained that sulphate of barytes, when in combination with an organic sulphate, shall be soluble. At this point, chemists turn rebellious. They will not permit it. If Nature is so extravagant as to make the ethylic bisulphates soluble, even when they contain barytes, chemists determine to set her right, and to do justice to the barytic test, by striking the organic bisulphates out of the catalogue of sulphates, and decorating them with some other title. They bind up the organic radical, the sulphur, and the oxygen, into an imaginary bundle, and they call this bundle a *Conjugated Acid* = $H + (C^2H^5,SO^2,SO^2)$. But what does that help them? The barytic salt is still soluble, and all they gain* is a new name which carries a false idea; namely, the idea that a sulphate cannot be present because it cannot be precipitated by barytes.

Examples of Organic Bisulphates :—

$\text{CH}^3, \text{SO}^2 + \text{HSO}^2$. Methyl sulphete cum hydra sulphete. Usual name, sulpho-methylic acid.

$\text{C}^3\text{H}^7, \text{SO}^2 + \text{BaSO}^2$. Propyl sulphete cum baryta sulphete. The barytic salt of trityl sulphuric acid.

$\text{C}^2\text{H}^5, \text{SO}^2 + \text{HSO}^2$. Ethyl sulphete cum hydra sulphete. Double sulphate of water and oxide of ethyle. Sulphovinic acid. Sulpho-ethylic acid.

There are a great number of such salts, and they are perfectly analogous to these examples.

The constitution of the conjugated acids has been fully investigated in my work on the Radical Theory.

21). $\left. \begin{array}{l} \text{NHR}^p, \text{H} \\ \text{NR}^p\text{R}^p, \text{H} \\ \text{NR}^p\text{R}^p, \text{R}^p \end{array} \right\} \text{Compound Ammonias.}$ In these salts, the 3 atoms of hydrogen are replaced by one, two, or three basic radicals; which may be of one kind or of different kinds.

Examples :—

$\left. \begin{array}{l} \text{NH}, \text{C}^2\text{H}^5; \text{H}. \\ \text{N}, \text{C}^2\text{H}^5, \text{C}^2\text{H}^5; \text{H}. \\ \text{N}, \text{C}^2\text{H}^5, \text{C}^2\text{H}^5; \text{C}^2\text{H}^5. \\ \text{N}, \text{CH}^3, \text{C}^2\text{H}^5; \text{C}^5\text{H}^{11}. \end{array} \right\} \begin{array}{l} \text{Ethylamine} \\ \text{Diethylamine} \\ \text{Triethylamine} \\ \text{Methyl-ethyl-amylamine, where the radicals} \\ \text{are different.} \end{array}$ In which the radicals are alike.

Similar ammonias occur in which either all or some of the radicals are negative, and others in which all or some of the radicals are metallic. The conclusion to be drawn is, that ammonias occur, in each of which there must be one atom of nitrogen with three other radicals, which may be either hydrogen, or metals, or compound radicals, positive or negative. In all cases the ammonia, however complex in composition, bears a characteristic relation to the normal ammonia NH^3, H . For an extended list of these compound ammonias, see "Radical Theory in Chemistry," page 199.

22). $\text{NR}^p\text{R}^p\text{R}^p\text{R}^p, \text{HO}$. *Hydrated Oxides of Compound Ammoniums.*

The formula of the hydrated oxide of normal ammonium is NH_4HO , which is exactly equivalent in chemical power to caustic potash $\text{K} + \text{HO}$. The four atoms of hydrogen which constitute ammonium are severally replaceable by compound basic radicals, either alike or different, and the resulting compound ammonium, though become very complex in constitution, still holds together and acts precisely like caustic potash. I may quote, as an example, Hoffmann's hydrated oxide of methylethylamylphenylammonium

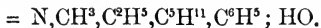

This great mass of ultimate atoms acts chemically as the equivalent of KHO and NH^4, HO . The conglomerate $\text{N}, \text{CH}^3, \text{C}^2\text{H}^5, \text{C}^3\text{H}^{11}, \text{C}^6\text{H}^5$, equal to $\text{N} + \text{C}^{14} + \text{H}^{24}$, containing in all 39 radicals, has the saturating capacity of only 1 radical.

23). R^p, CNO . *Cyanates*.

The cyanates consist of one atom of cyanogen, one atom of oxygen, and one basic radical.

Example :—

$\text{C}^2\text{H}^5, \text{CNO}$. Ethyla cyanate. Cyanate of ethyl.

24). $\text{NHHHH}; \text{CNO}$. *Cyanate of Ammonia*. *Urea*.

25). $\text{NR}^p\text{R}^p\text{R}^p\text{R}^p; \text{CNO}$. *Compound Ureas*.

The Urea theory is a subject of much controversy, and I have entered upon a careful examination of it in my work on the Radical Theory. The details are too copious for introduction here. See page 381.

Normal urea contains 4 atoms of hydrogen in its basic ammonium, the replacement of which by compound basic radicals, one or more at a time, and of the same or different kinds, gives rise to a considerable variety of compound ureas, as is shown by the following formulæ:—

$\text{NH}^3, \text{CH}^3; \text{CNO}$	Urea containing 1 atom of methyl.
$\text{NH}^2, \text{C}^2\text{H}^5, \text{C}^2\text{H}^5; \text{CNO}$	„ 2 atoms of ethyl.
$\text{NH}^2, \text{C}^2\text{H}^5, \text{C}^3\text{H}^{11}; \text{CNO}$	„ 1 atom each of ethyl and amyl.
$\text{N}, \text{C}^2\text{H}^5, \text{C}^2\text{H}^5, \text{C}^2\text{H}^5, \text{C}^3\text{H}^5; \text{CNO}$	„ 4 atoms of ethyl.

Ureas containing Acid Radicals.

A few instances are known in which one atom of hydrogen contained in cyanate of ammonia is replaced by an acid radical, in which case the salt, as is usual when an acid radical comes to act as a basic radical, takes up an additional atom of oxygen. Examples:

$\text{NH}^3, \text{C}^2\text{H}^3; \text{CNO}^2$	Urea containing 1 atom of acetyl.
$\text{NH}^3, \text{C}^5\text{H}^9; \text{CNO}^2$	„ „ valeryl.

Compounds of this kind are commonly called *Ureides*. Only a few are known, but probably many others could be prepared.

B. COMPOUNDS PRODUCED BY ACID RADICALS.

26). H, R^n . *Hydrides of Negative Radicals*. Compounds, each of which contains one negative radical and one atom of hydrogen. Examples:—

$\text{H}, \text{C}^3\text{H}^5$	Hydra propionyla.	Propylene.
$\text{H}, \text{C}^4\text{H}^7$	Hydra butyryla.	Butyrine. Butylene.
$\text{H}, \text{C}^5\text{H}^9$	Hydra valeryla.	Valerine. Amylene.

H, C^6H^{11} .	Hydra caproyla.	Hexylene.	Caproilene.
H, C^7H^7 .	Hydra toluenyla.	Toluine.	
H, C^8H^{15} .	Hydra capryla.	Caprylene.	Octylene.
$H, C^{16}H^{31}$.	Hydra palmityla.	Cetene.	Cetylene.
$H, C^{27}H^{53}$.	Hydra cerotyla.	Cerene.	

The compounds of this series, like those of series 1) and 2), contain in each an even number of atoms of hydrogen, and as that even number of atoms indicates in each compound the presence of two radicals, it follows that when these compounds are gaseous, they possess an atomic measure of two volumes; or, in other words, the specific gravity of their gases is equal to half their atomic weight.

There are Five kinds of Hydrocarbons.—1). *Positive or Basic Radicals*, in which the hydrogen is present in an uneven number of atoms. Of these radicals, Group A, page 401, gives a distinct idea. 2). *Negative or Acid Radicals*, in which also the hydrogen is present in an uneven number of atoms. Group B, page 402, shows examples of radicals of this description. There exist a very few radicals with an even number of atoms of hydrogen, but these are rare exceptions to an otherwise general rule. See Groups C, E, I, L, N. 3). *Compounds of Basic Radicals with Hydrogen*. See Group 1, page 414. 4). *Compounds of Acid Radicals with Hydrogen*. See Group 26 above. 5). *Compounds of Basic Radicals with one another*. See Group 2, page 414. The last three kinds have all necessarily an even number of atoms of hydrogen. When these compounds are gaseous, the atomic measures of those of 1) and 2) are one volume; the atomic measures of those of 3), 4), and 5) are two volumes. In many works on Organic Chemistry, these varieties of hydrocarbons are discriminated very vaguely.

27). R^n, R^mO . Protoxides.

This group of compounds should be parallel to those of Group 3); but as in mineral chemistry we readily find protoxides of basic radicals, but do not so readily find protoxides of negative radicals, so in organic chemistry the compounds of this group are not so abundant as those of Group 3). The following is, however, an example in point:—

CH, CHO . Formyla formylate. This is the compound usually called pyrogallic acid.

28). R^p, R^qO . Ketones, or Acetones.

A ketone contains one acid radical combined with one atom of oxygen, and with one basic radical, in which there is C¹ less than in the acid radical. Examples:—

CH^3, C^2H^3O .	Methyla acetylate.	Acetone.
C^3H^7, C^4H^7O .	Propyla butyrylate.	Butyrone.
C^4H^9, C^5H^9O .	Butyla valerylate.	Valerene.

The ketones contain one equivalent of carbonic acid = CO^2 , less than the Anhydrides of the same acid radicals. Thus:—

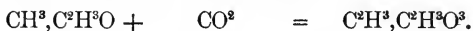

Acetone + Carbonic acid = Acetic Anhydride.

As the ketones contain two radicals they have in the gaseous state an atomic measure of two volumes.

Acetone is prepared by submitting acetate of potash to dry distillation. Two atoms of that salt are decomposed. Carbonate of potash is formed, and acetone distils over:—

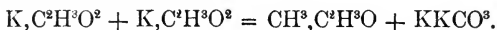

The other ketones are prepared by a corresponding process, performed upon such salts as the benzoates, valerates, butyrates, margarates, stearates, &c. This experiment shows one of the easy methods by which acid radicals are converted into basic radicals.

29). $\text{H}, \text{R}^n\text{O}$. *Aldides or Aldehyds.*

An Aldehyd consists of an acid radical combined with one atom of hydrogen and one atom of oxygen. It differs from an Alcohol, (No. 5), by containing an acid radical instead of a basic radical. It differs from a hydrated organic acid, (No. 30), by containing a smaller quantity of oxygen in combination with the same quantity of radicals. Examples:—

$\text{H}, \text{C}^2\text{H}^3\text{O}$. Hydra acetylate. Aldehyd.

$\text{H}, \text{C}^7\text{H}^5\text{O}$. Hydra benzylate. Oil of bitter almonds. Hyduret of benzoyl.

$\text{H}, \text{C}^4\text{H}^7\text{O}$. Hydra butyrylate. Butyric aldehyd.

$\text{H}, \text{C}^5\text{H}^9\text{O}$. Hydra valerylate. Valeric aldehyd.

$\text{H}, \text{C}^{10}\text{H}^{19}\text{O}$. Hydra rutylylate. Rutic aldehyd.

$\text{H}, \text{C}^9\text{H}^7\text{O}$. Hydra cinnamylate. Oil of cinnamon.

$\text{H}, \text{C}^{30}\text{H}^{53}\text{O}$. Hydra melissylate. Melene.

The combination of a single atom of oxygen with each of these aldehyds converts it into an acid of Group 30). Thus:—

$\text{H}, \text{C}^2\text{H}^3\text{O}^2 =$ Hydra acetylete. Hydrated acetic acid.

The combination of H^2 with each of the aldehyds would convert it into a compound of Group 5), namely, an alcohol containing a basic radical

30). $\text{H}, \text{R}^n\text{O}^2$, or $\text{H}, \text{R}^n\text{O}^3$. *Hydrated Organic Acids.*

An organic acid consists of a compound acid radical combined with an atom of hydrogen acting as a basic radical, and commonly with two but sometimes with three atoms of oxygen. The monobasic acids of the vinyl series, Group B, page 402, have always two atoms of oxygen. Some radicals of other series require three atoms. The reason why is not apparent. Succinyl = C^2H^2 , requires O^2 for the monobasic succinates = $\text{H}, \text{C}^2\text{H}^2\text{O}^2$; but tartryl = C^2H^2 , requires O^3 for the monobasic

tartrates = $H, C^2H^2O^3$. Now it *may be*, that is to say, it is *possible*, that the difference between the succinates and the tartrates is a difference only in the degree of oxidation, but it may also consist in a difference in the nature of the proximate constitution of the two radicals, whose ultimate constitution is C^2H^2 and C^2H^2 . Other cases of this kind occur in sufficient frequency to call attention to this peculiarity. Thus, if we compare acetic acid = $H, C^2H^3O^2$ with glycollic acid = $H, C^2H^3O^3$, we cannot but ask, is the difference in these acids a difference of oxidation only, or a difference depending upon the constitution of the radicals? If we incline to the opinion that the difference is only one of oxidation, and consider the radicals to be alike, then we must ask, what of the radical which bears the formula C^2H^3 ? Is it glycolyl, or allyl, or propionyl, or lactyl? Do these names mean one thing, or so many different things? Certainly, much remains to be done in respect to the discrimination and identification of organic radicals.

In the preceding table of radicals, I have attached to each acid radical the form of its hydrated acid. In all cases, the basic hydrogen denoted by H, is supposed to be replaceable by any basic radical; by a metal such as K, Na, Ba, Pb, or Ag, or by a compound organic radical such as methyl CH^3 , ethyl C^2H^5 , amyl C^5H^{11} , &c. In all these cases a Neutral Organic Salt is produced.

All the acid radicals of the vinyl series, from No. 33 to 60, give rise to oily, fatty, or waxy substances. Some of the other acid radicals, such as benzyl, cumyl, &c, produce volatile essences, and some produce the important acids which give flavour to the juice of fruits, such as lemons, oranges, apples, pears, grapes, &c. Thus, while one class of organic salts derived from sugar produce the odour and flavour of fruits (see page 387), another class of salts, also produced from sugar, give them their acidity or their oiliness.

31). $\left. \begin{array}{l} R^n, R^n O^3. \\ R^n, R^n O^5. \end{array} \right\} \text{ Anhydrides, or Anhydrous Acids.}$

The Anhydride of an Organic Acid, or, as it is also called, an Anhydrous Organic Acid, consists of two acid radicals combined with three or with five atoms of oxygen. The compound anhydrides have a similar composition, save that the two acid radicals are of different kinds. When the normal hydrated acid contains two atoms of oxygen, then the anhydride has three atoms. When the hydrated acid contains three atoms of oxygen, the anhydride has five atoms. A general notice respecting the anhydrides has been given at page 295. A more complete account will be found in my work on the Radical Theory. In all cases the anhydrides are convertible, by combination with water, into the normal hydrated acids. Thus:—

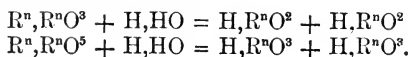

One equivalent of each anhydride, and one equivalent of water, are equal to two equivalents of the hydrated acid.

32). $H, R^nO^2 + H, HO,$ or H^2, R^nO^2 . *Polybasic Acids.*

The term *polybasic acid* implies that you can have compounds in which *one* acid radical exists in combination with *several* basic radicals. The *special kinds* of polybasic acids, to which reference is chiefly made, are the *bibasic* acids and the *tribasic* acids. As the notion of polybasic properties is quite adverse to the leading assumption of the radical theory (see page 122), that a salt contains only two radicals, I must enter upon such an explanation of the theory of polybasic acids as will enable the student to see what are the facts, or apparent facts, or things falsely assumed to be facts, upon which that doctrine is founded.

32 a). *Bibasic nature of the Carbonates.*—The constitution of the carbonates has been fully explained at page 359. If we take the formula KK, CO^2 , we appear to have a veritable bibasic acid; so have, we also if we take the formula by which the carbonates are more generally indicated, that, namely, where two-thirds of their oxygen is ascribed to the carbon and one-third of it to the metals $KKO + COO$. But, I have shown that we may consider the carbonates to be double salts, formed in accordance with the formula $KO + KCO^2$, and in this sense the acid radical C is not to be considered as endowed with the power of neutralising two basic radicals at once. Still, as there is no doubt of the fact, that in one equivalent of a carbonate we have two basic radicals and one acid radical, the salt is effectively bibasic, and must be treated as such in all experiments and computations.

32 b). *Bibasic nature of the Salicylates.*—The salicylates have this formula, $HH, C^7H^4O^3$, and their salts appear to be bibasic, since the two atoms of basic hydrogen are replaceable by different basic radicals, so as to produce such salts as $Ba, Cuc; C^7H^4O^3$, and $Ag, CH^3; C^7H^4O^3$. But it is evident that this kind of bibasic power may exactly resemble that of the carbonates, in virtue of which power the true composition of these salts may be $BaO + Cuc, C^7H^4O^2$, and $AgO + CH^3; C^7H^4O^2$; in which cases these compounds are to be regarded as bibasic in the same sense as the carbonates.

32 c). *Bibasic and Tribasic Phosphates.*—The formula of hydrated phosphoric acid is H, PO^3 . It is monobasic. But it can combine with an atom of water, or with any salt formed on the model of water, such as KHO and KKO , and thus produce the following compounds, all of which have been called tribasic phosphates:—



Here we have apparent cases of the combination of one atom of the acid radical P, with three atoms of the basic radicals H and K. Yet w

perceive that we may fairly consider all these compounds as consisting of a monobasic phosphate in combination with another salt formed on the model of water, containing indeed only one atom of oxygen, but containing also the *two radicals* which form the acknowledged elements of a salt.

It is found experimentally that the bibasic phosphates combine with the monobasic phosphates to form an intermediate salt; or rather, we produce many intermediate salts, which agree in constitution with a compound of the other two salts. An example of this description is shown at B in the following Table:—

Classes of Phosphates.	Analytical Formulæ.	Synoptical Formulæ.
A. Monobasic, or metaphosphate	KPO^3	$= K P O^3$
B. Bibasic, or pyrophosphate	$KPO^3 + KPO^3 + KKO$	$= K^4 P^2 O^7$
C. Tribasic, or common phosphate	$KPO^3 + KKO$	$= K^3 P O^4$

32 d). *Polybasic Acetates*.—The regular formula of the acetates is $H, C^2H^3O^2$, which represents a monobasic acid; but among the numerous basic salts of this acid, many occur which seem to indicate the existence of relations similar to those that exist among the phosphates.

Classes of Acetates.	Analytical Formulæ.	Synoptical Formulæ.
A. Monobasic Acetates	$Pb, C^2H^3O^2$	$= Pb, C^2H^3O^2$
B. Bibasic Acetates		
C. Tribasic Acetates	$Pb, C^2H^3O^2 + Pb, C^2H^3O^2 + PbPbO$	$= Pb^4, (C^2H^3)^2 O^5$
	$Pb, C^2H^3O^2 + PbPbO$	$= Pb^3, C^2H^3 O^3$

A great many acids, both organic and inorganic, form salts of this description. According to the radical theory, they are to be considered as double and triple salts, and not as salts of bibasic acids or tribasic acids. As an example of a salt of this character, I may quote a sulphate which contains three atoms of ethyl, one of sulphur, and three of oxygen. The formula is $(C^2H^3)^3, SO^3$. Is this to be considered as a *tribasic sulphate*? By no means. It is simply a double salt containing sulphate of ethyl, in combination with ether $C^2H^5, SO^2 + C^2H^5, C^2H^5 O$. There would never have been any difficulty about double salts such as this had not chemists too readily taken up the crude idea that organic compounds must needs differ in constitution and equivalence from inorganic compounds, which is not the case.

32 e). *Polybasic Vegetable Acids*:—

<i>Tribasic Aconitic Acid</i>	$= H^3, C^6H^3O^6$
<i>Tribasic Citric Acid</i>	$= H^3, C^6H^5O^7$
<i>Bibasic Malic Acid</i>	$= H^2, C^4H^4O^5$
<i>Bibasic Citraconic Acid</i>	$= H^2, C^5H^4O^4$
<i>Tribasic Gallic Acid</i>	$= H^3, C^7H^5O^6$

I might add to this list the names of many other acids of the organic series, which are usually assumed to be bibasic or tribasic. But it is needless to accumulate examples where only a principle is to be explained.

The circumstance that in the salts of the vinylic acids, and in those of many other acids, a neutral monobasic salt contains only two atoms of oxygen, and only a very few require three atoms, necessarily gives rise to the suspicion that acids with four, five, six, and seven atoms of oxygen, as shown in the above formulæ, are not simple salts but double or triple salts; and many other circumstances, particularly the nature of the amidogen salts of these complex acids, tend to strengthen that suspicion until it becomes not only a probability but almost a certainty. A careful examination of the details respecting these acids seems to show that in the juices of fruits there exist several acids of a very simple composition, of which I have ventured to cite the following:—

$H, C^2H O^2$	called	provisionally	Dylic acid.
$H, C^2H^3O^3$	ditto		Mylic acid.
$H, C^3H^3O^2$	ditto		Trylic acid.

These three acids, and all the salts produced by the replacement of their basic hydrogen by other radicals, have the property of combining with one another in various groups and proportions, one to one, one to two, &c., and producing crystallisable double or triple salts. For anything that appears to the contrary, this combination of the salts into groups takes place upon some such principle as that which leads to the formation of the quadruple salts commonly called alums. In the intercombination of these organic acids, the power is reserved to each of them to act like an independent acid, so that, in a combination of two acids, one may remain acid and the other be rendered neutral, one may have ammonium for a base, and the other by abstraction of HHO be converted into an amidogen salt with a minimum of oxygen.

The combinations of these acids into the vegetable groups that pass by the name of citric acid, aconitic acid, malic acid, citraconic acid, and gallic acid, have been briefly explained at page 405, and in a separate publication (The Radical Theory in Chemistry, article, Theory of Polybasic and Conjugated Acids), I have explained this matter in detail, and given the facts and arguments upon which the opinions now expressed are founded. The space at my command here does not permit of my quoting more than a few formulæ.

32f). *Malic Acid*.— $H, C^2H^3O^3 + H, C^2HO^2$. This double salt shows the composition of malic acid, the acid of apples, the berries of the mountain ash, &c. The two atoms of basic hydrogen can each or both be replaced by metals or other basic radicals, similar or dissimilar and thus give rise to a great variety of double salts.

$NH^2, C^2H^3O^2 + H, C^2HO^2$. In this example, one of the normal salt

is converted into an amidogen salt. The product is a compound which resembles the oxamic acid described at page 379, and indeed it belongs to a class of compounds which are called amidogen, amidated, or amided acids. The special name of the acid produced in this example is *aspartic acid*. When the remaining atom of basic hydrogen is replaced by a basic radical, the salt becomes an aspartate, such is $\text{NH}^2, \text{C}^2\text{H}^3\text{O}^2 + \text{K}, \text{C}^2\text{HO}^2$, which is called the aspartate of potash.

When both the acids, which together constitute malic acid, are converted into amidogen salts, thus: $\text{NH}^2, \text{C}^2\text{H}^3\text{O}^2 + \text{NH}^2, \text{C}^2\text{HO}$, the compound so produced is called *Asparagine*. This last compound is produced in the root of a plant, even before leaves have grown, to furnish its laboratory for converting the ingredients of the air into sugar for its nourishment.

32 g). *Citric Acid*. — I have assumed that its composition is $\text{H}, \text{C}^2\text{H}^3\text{O}^3 + \text{H}, \text{C}^2\text{HO}^2 + \text{H}, \text{C}^2\text{HO}^2$, and that it has three atoms of basic hydrogen, which are collectively or severally replaceable by other basic radicals. It can be proved incontestably that each of the three salts which thus together constitute the crystallisable salt called citric acid, can do and suffer all that it is usual for any single normal salt to do or suffer. For example, you can have a citrate with one or two or three atoms of amidogen, and with hydrogen radicals, metallic radicals, and compound organic radicals, intermixed in any manner that can agree with the transmutations of three radicals. So long, however, as the three salts, or the residues of the three salts, adhere together, you have a citrate, either normal, or only so far modified that it remains reconvertible into a citrate. If the combination of the three salts is effectually overcome, you have then other salts, not reconvertible into citrates. Thus, $\text{H}, \text{C}^2\text{HO}^2$, which I have called Dylic acid, may, when isolated, become aconitic acid, or malic acid, or fumaric acid. I do not know whether these acids are the same or different. Strangely enough, chemists have given to aconitic acid the formula $\text{HHH}, \text{C}^6\text{H}^3\text{O}^6$, reckoning it to be a tribasic acid; for which the only evidence is that it forms three kinds of salts, namely, a) $\text{H}, \text{C}^2\text{HO}^2$; b) $\text{K}, \text{C}^2\text{HO}^2 + \text{H}, \text{C}^2\text{HO}^2$; and c) $\text{NH}^2, \text{C}^2\text{HO}^2 + \text{H}, \text{C}^2\text{HO}^2 + \text{H}, \text{C}^2\text{HO}^2$. These salts are sufficiently intelligible as single, double, and triple salts, and they gain nothing from the tribasic theory. The following formula, $\text{H}, \text{C}^3\text{H}^3\text{O}^3 + 2(\text{H}, \text{C}^2\text{HO}^2)$, represents citric acid as a triple acid. If you have one atom less of $\text{H}, \text{C}^2\text{HO}^2$, then you have malic acid. If you have $\text{H}, \text{C}^2\text{HO}^2$ in combination with $\text{H}, \text{C}^3\text{H}^3\text{O}^3$, you have citraconic acid. If you have $\text{H}, \text{C}^3\text{H}^3\text{O}^2$ alone, it probably is acrylic acid. But if the same radicals, or radicals of the same kind and quality, take up O^1 extra, then you have $\text{H}, \text{C}^3\text{H}^3\text{O}^3$ pyruvic acid—an acid which is produced when heat is applied to tartaric acid.

It is well known that the acid juice of a fruit rarely consists of a single acid. Usually several acids are present together. Thus malic

acid occurs abundantly in unripe apples, gooseberries, and currants, in which it is accompanied by citric acid, and often by tartaric acid. It occurs also in the stalks of garden rhubarb, in company with citric, oxalic, and phosphoric acids. It is found in the berries of the mountain ash in company with the recently-discovered sorbic acid, to which the formula $H_2C^6H^7O^8$ has been ascribed.

Now it is certainly possible, it is even probable, that the acid juices of plants, instead of containing several complex bibasic and tribasic acids, do contain several monobasic simple acids, each destined to some peculiar purpose, at present unknown to us, and that these simple acids combine with one another, and according as one or the other of them prevails, either in the natural juices or in the modifications which the transmutative power of the chemist makes the extracted juices to undergo, they produce citric acid, or malic acid, or citraconic acid, or mixtures of the whole to suit attendant circumstances.

32 h.) *Bibasic Acids of the Succinic Group.*—I have referred in the account of the radicals, Group C, page 403, and Group E, page 407, to certain acids which give double salts, after the manner of the oxalates and sulphates, and which for that reason only have been converted into *apparently* bibasic salts, by the short and easy process of doubling the formulæ of their acid radicals. A bibasicity, which is thus *made for a purpose*, is a very different thing from such a bibasicity as that of the carbonates and salicylates, which is natural and unavoidable.

32 i.) *The Glycerides.*—There are several organic acids formed by compound radicals having the formula C^3H^5 . This radical occurs in allylic acid under the name of allyl; in propionic acid under that of propionyl; in lactic acid as lactyl; and in glycerine it appears as the radical glycyll. Whether or not these four names signify one and the same thing, I cannot tell. There exists, at any rate, a compound termed glycerine, which agrees with the formula $H^3C^3H^5O^3$. There is another termed allylic acid, which has the composition exhibited by $H_2C^3H^5O^3$. The former of these bears to the latter the relation of a tribasic acid to a monobasic acid, for the constitution of it may be represented as $H_2C^3H^5O^3 + HHO$. These two acids very probably bear this relation to one another, so that, if the radical C^3H^5 is called glycyll, one of these acids is *monobasic* and the other *tribasic* glycyll-acid. It is with the tribasic acid, or glycerine, that we have to deal in this place.

The three atoms of basic hydrogen contained in glycyllic acid are severally and collectively replaceable by other basic radicals, and this acid has the property of taking up by preference the radicals of the fatty acids, many of which, while capable of acting as acid radicals against hydrogen and the metallic radicals, act against glycyll as basic radical. This affection produces the remarkable result that an acid radical

rather simple form, C^3H^5 , appears to neutralise three other radicals of very complex form, such as stearyl = $C^{18}H^{35}$, producing compounds which, considered in relation to their ultimate constitution, are extremely complex, but not so when considered as double salts, composed of compound radicals. Take for example the following three kinds of stearin, all of which exist as natural fats, and can also be prepared artificially:—

Unitary Formulæ showing the Ultimate Atoms.	Synoptical Formulæ.		
1. $C^3 H^8 O^3 = H$,H	,H	; $C^3H^5O^3$
2. $C^{21}H^{42} O^4 = H$,H	, $C^{18}H^{35}$; $C^3H^5O^4$
3. $C^{39}H^{76} O^5 = H$, $C^{18}H^{35}$, $C^{18}H^{35}$; $C^3H^5O^5$
4. $C^{57}H^{110}O^6 =$	$C^{18}H^{35}$, C^8H^{35}	, C^8H^{35} ; $C^3H^5O^6$.

No. 1 is glycerin, 2 is monostearin, 3 is bistearin, 4 is terstearin.

Here we have a series of salts in which the basic hydrogen of the acid is replaced by one, two, or three equivalents of another radical, which acts in these examples as a basic radical; but being of a kind which usually acts as an acid radical, it requires for these salts an additional quantity of oxygen to compensate for its deficiency of basic power. This point has been explained in the theory of the anhydrides given at page 295. Each acid radical, which goes into the salt as a basic radical, takes with it in these examples *one* additional atom of oxygen, because the normal stearates require only two atoms. Hence we have,

1. The tribasic glycollic acid, with O^3
2. The salt with one atom of stearyl, with O^4
3. The salt with two atoms of stearyl, with O^5
4. The salt with three atoms of stearyl, with O^6 .

When the glycollic acid exchanges its basic hydrogen for compound radicals, which in their normal state are also basic, then, of course, the glycolate, or glyceride, so produced, has no additional oxygen. Thus, for example, the salt called biethylin, which contains two atoms of ethyl, has the following formula:—



The radicals of other fatty acids, act with glycerine exactly in the same manner as stearyl, so that salts of the same three general forms as the above—monobasic, bibasic, and terbasic—can be produced with all the following radicals, doubtless among many others:—

Acetyl	= C^2H^3	producing the three varieties of Acetin.	
Benzyl	= C^7H^5	„	Benzoicin.
Butyryl	= C^4H^7	„	Butyirin.
Oleyl	= $C^{18}H^{33}$	„	Olein.

Palmityl = C ¹⁶ H ³¹	producing the three varieties of Palmitin.
Stearyl = C ¹⁸ H ³⁵	„ „ Stearin.
Sebamyl = C ⁵ H ⁹	„ „ Sebacin.
Valeryl = C ⁵ H ⁹	„ „ Valerin.
Margaryl = C ¹⁷ H ³³	„ „ Margarin.

The fats, or glycerides, or glycyllates, whether monobasic, bibasic, or terbasic, when boiled with a solution of caustic potash, all yield glycerine of the same composition and condition of hydration. Why? Let us see. I will take the three stearins already quoted as examples:—

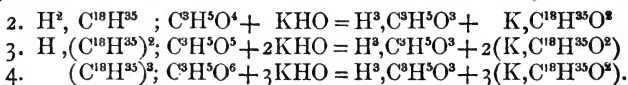

These quotations show that every individual radical of the fatty acids, when disengaged from a glycerine salt, takes up K¹ from KHO (caustic potash), and that the quantity of HO thus liberated from KHO is in all cases exactly sufficient to convert the liberated glycol into the tribasic glycollic acid, H³, C³H⁵O³.

The constitution of the glycerides, and of glycerine, which has been most absurdly treated as a teratomic alcohol instead of a tribasic acid, have been fully investigated in my treatise on the Radical Theory. The conclusions which I have arrived at are, I think, fully justified by the evidence which is collected in that work.

33). NH⁴, RⁿO². *Ammonium Salts with Compound Acid Radicals.*

The radical ammonium = NHHHH, replaces the basic hydrogen of any hydrated organic acid, No. 30), and produces a neutral salt. The ammonium is applied in the state of hydrated oxide = NH⁴,HO. Thus: H, C²H³O² + NH⁴,HO = NH⁴, C²H³O² + H,HO. Acetic acid + hydrated oxide of NH⁴ = acetate of ammonia + water. The other hydrated organic acids act in the same water, and therefore produce an extensive series of salts of ammonium. Similar salts are also produced, containing those compound ammoniums in which the hydrogen is more or less replaced by other radicals. See No. 22), page 419. In many cases these organic salts of ammonia combine with hydrated organic acids, and produce acid salts in accordance with the general formula NH⁴, RⁿO² + H, RⁿO².

34). NH², RⁿO. *Amidogen Salts with Compound Acid Radicals. Amids.*

The ammonium salts with organic acid radicals just referred to in Article 33) undergo the same kind of decomposition as that by which oxamid is produced from oxalate of ammonia. See page 378. Thus, the acetate of ammonia, on being deprived of an atom of water, produces a compound called acetamid:—

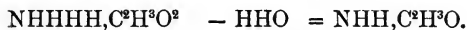

Acetate of ammonia - Water = Acetamid.

In this manner a vast number of compounds are procured, to which chemists have given the name of AMIDS. Examples: $\text{NH}^2, \text{C}^7\text{H}^5\text{O} =$ Benzamid; $\text{NH}^2, \text{C}^5\text{H}^3\text{O} =$ Valeramid; $\text{ZH}^2, \text{C}^9\text{H}^7\text{O} =$ Cinnamid. But other substances, not usually called Amids, appear to belong to that category. For example:—

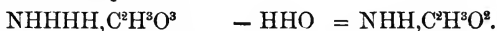

Glycollate of ammonia - Water = Glycoll.

The amids are crystallisable substances, neutral to test-papers, and do not combine with acids to produce salts. Hence they are salts and not basic radicals.

There are several methods of preparing amids.

1. By the action of a solution of ammonia on compound ethers. Thus:—

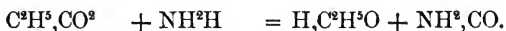

Oxalic ether + Ammonia = Alcohol + Oxamid.

In this case the oxalate of ether with ammonia produce alcohol and oxamid.

2. By the action of carbonate of ammonia on the oxychlorides of organic radicals. Thus:—



Oxychloride of benzoyle + Carbonate of ammonia = Sal ammoniac

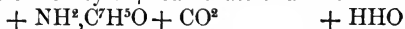

+ Benzamid + Carbonic acid + Water.

The carbonic acid goes off with effervescence; the sal ammoniac and excess of carbonate of ammonia are washed away with water, in which the benzamid is but sparingly soluble.

3. By the action of ammonia on the anhydrides. Example:—



Benzoic anhydride + Ammonia = Benzamid + Benzoic acid.

Reconversion of Amidogen Salts into Ammonium Salts.—When the amidogen salts are boiled in water, which contains a little free acid, salts of ammonium are produced:—



If they are boiled with caustic alkali, salts of that alkali are produced, and ammonia is set free:—



As there are many varieties of amidogen salts, it is necessary to give some notion of the principal kinds.

- a). The normal amidogen, oxamid, produced by the abstraction of HHO from oxalate of ammonia.

All the other amidogens are so far parallel to this one that they consist of normal salts of ammonium *minus* HHO.

- b). Derived from the neutral oxalates of vice-ammoniums :

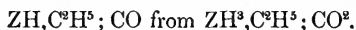

- c). Derived from neutral salts formed by normal ammonium with organic acids :

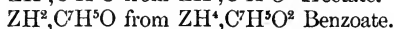

- d). Derived from the neutral salts formed by compound ammoniums with organic acids :

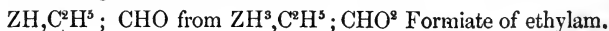

II. EXAMPLES OF ORGANIC SALTS.

FIRST SERIES.—SALTS PRODUCED BY ACID RADICALS.

ACETIC ACID.—VINEGAR.

Formula, $\text{H, C}^2\text{H}^3\text{O}^2 =$ Hydra acetylete; *Equivalent*, 60; *Atomic measure in the gaseous state*, 2 volumes; *Specific gravity of gas*, 30.

Hydrated acetic acid is a combination of the radical acetyl = C^2H^3 with one atom of hydrogen = H, and with two atoms of oxygen = O^2 . The radical acetyl has not yet been isolated.

Acetic acid is the best known and most important of the organic acids. When greatly diluted with water, it is called vinegar. It does not appear to exist in the juices of plants, but it is readily formed during various decompositions of the radicals of the vinyl series, of which I will give some particulars. It is often spontaneously produced under circumstances when we do not desire its presence, namely, in wine, beer, syrup, in cooked food, and in the expressed juices of fruits, when not sufficiently protected from the action of the air.

Phenomena which attend the destructive distillation of Oak, Beech, Box, or other hard wood.—I have already shown, at page 61, that when vegetable substances are burnt in close vessels, they produce charcoal, vinegar, and other volatile products. I proceed to describe a method of making that experiment with more exactness. This requires the apparatus represented in fig. 378, page 433 :—

Letter *a* represents a hard glass tube, half an inch in diameter, and about ten inches long; *b*, a tube about three-quarters of an inch diameter, bent at the middle; *c*, is a gas-delivery tube; *d*, a pneumatic trough; *e*, a jar for collecting gas over water. The tubes, *a*, *b*, *c*, may

be connected together either by corks, or collars of caoutchouc. Half fill the short branch of the tube, *a*, with bits of dry, hard wood, free

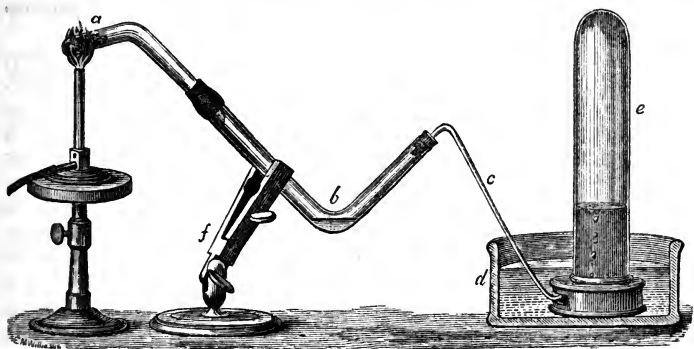

378.

from turpentine. Connect the parts of the apparatus, and apply to *a*, the heat of a gas flame or spirit lamp. In a short time two liquors will collect in the bend of the tube *b*, and gas will rise in the receiver *e*. Of the first gas which comes over, a quantity equal to about twice the capacity of the apparatus, *a*, *b*, *c*, should, for the reason stated at page 180, be collected apart from that to be afterwards collected in the receiver *e*. The whole of this process of dry distillation is to be performed exactly like that already described at page 325, in reference to the distillation of bones.

Examination of the products of the distillation. In a), the retort.—The residue is charcoal. See page 62, as to the means of proof. This charcoal contains a small quantity of ash. It should be burnt carefully to isolate the ash. See pages 327 and 336, as to the methods of burning the carbon from the ash. It will be found, that the ash left by wood charcoal is much smaller in proportion than that left by bone black. See page 327. It will also be found upon trial, not to consist of phosphate of lime, but chiefly of carbonates of potash and soda, with a little sulphate, chloride, and silicate of those bases.

In b), the bent receiver.—Two liquids will be found, a thick, brown liquor, and a thin, clear one, pale in colour. Both of these liquors contain a great variety of products, but the principal ingredients in the clear liquid are acetic acid and wood-spirit, with more or less acetone and acetate of methyl, dissolved in water. The brown liquor, or oil, which is only partially soluble in water, is commonly called wood-tar, and contains a great variety of substances, which differ according to the kind of wood made use of, the degree of heat at which it is charred, and various other circumstances. Among the substances so produced, I

may name the following, for special descriptions of which I have no space. a). Hydrocarbons—such as toluole, cymole, xylole, eupion. b). Oxidised bodies—kreasote, picamar, kapnomor. c). Solid portions—paraffin, naphthalin, and many others.

In e), the gas-receiver.—Mixed gases, variable in number and quality, but usually including marsh gas H,CH^3 , olefiant gas (vinyl) CH^2 , carbonic acid gas CO^2 , and carbonic oxide gas CO . The hydrocarbons usually preponderate, and yield a gas which is combustible with a brilliant flame, for which reason, in some countries, where coal is dear and wood cheap, wood-gas is used instead of coal-gas.

Experiments.—The two liquors in the bent receiver, b), can be separated by decantation or by means of a pipette. The brown, tarry liquor, is too small in quantity and too complex in composition to afford useful experiments on this small scale. But in the clear liquor it is possible to show the presence of acetic acid, first, by its action on litmus, secondly, because it is volatile, and finally, because you can combine it with bases, and so determine the special character of the acetates. Acetone, wood-spirit, and the other volatile bodies, are present in such an experiment in quantities too small for separation and particular examination.

The decanted impure acetic acid may be neutralised by the addition of a solution of carbonate of soda, and then be evaporated to dryness and gently heated. The heat drives off the volatile substances, and also decomposes and expels a quantity of the tarry matters which had dissolved in the acid. The acetate of soda is then to be dissolved in water, filtered, concentrated by evaporation, and crystallised. The crystallised acetate of soda is afterwards to be mixed in a retort with hydrated sulphuric acid, and submitted to distillation, upon which purified hydrated acetic acid distils over, and sulphate of soda remains in the retort :

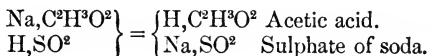

These particulars show the leading facts of the process by which a vast quantity of the acetic acid, or pyroligneous acid, which is employed in the arts, is prepared for sale. For details of this manufacture, I refer the reader to Muspratt's *Chemistry applied to the Arts and Manufactures*.

Theory of the Decomposition of Wood and production of Acetic Acid and other products.—I have stated at page 384, what is the composition of woody fibre, or cellulose, the organised body which mainly constitutes the substance of the hard woods, affected more or less by the inspissated juices of the plants which remain between the fibres. The decomposition affords an immense variety of products, which will be best shown by a few equations :—

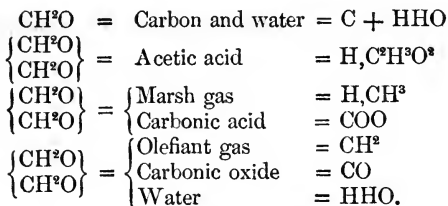

These represent the most important of the bodies produced by the dry distillation or imperfect combustion of wood. The tarry matters are too numerous and complex to be explained in this place.

Other Methods of producing Acetic Acid.

From Alcohol.—In Germany, and other countries, where alcohol is cheap, vinegar is prepared by the oxidation of alcohol. For that purpose, diluted alcohol (brandy, beer, wine, &c.) is made to trickle slowly over an extensive surface of thin box-wood shavings, contained in large wooden vats or casks, arranged in the manner exhibited by fig. 379.

B represents a cask filled with box-wood shavings; b, is a tray containing alcohol, which slowly trickles down through many small holes made in the bottom of the tray, and falls upon the shavings; c, c, c, represent a series of holes intended to admit atmospheric air near the bottom of the cask. The air rises upwards through the shavings, communicating oxygen to the descending alcohol, and the residue of the air escapes by the tubes which pass through the tray, two of which are shown in the figure.

The oxidised alcohol, on reaching the bottom of the cask, where there is a false bottom to support the shavings, passes off by a syphon into the receiver, a.

It is returned to the cask, and passed several times through the wood-shavings, until it is found to be sufficiently acidified.

A comparison of the constitution of alcohol and vinegar shows what occurs in this operation:—

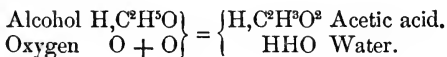

The first action of the oxygen is to reduce the radical ethyl, C^2H^5 , to acetyl, C^2H^3 , by taking away two atoms of hydrogen to produce an atom of water = HHO . The alcohol is by that reduction converted into aldehyd = $\text{H}, \text{C}^2\text{H}^3\text{O}$. The second action of the oxygen is to convert aldehyd into acetic acid:—



379.

If diluted alcohol is made to drop slowly from a pointed funnel upon the metallic substance called platinum black, placed in a capsule under a bell jar, in which there is a free circulation of air, the conversion of the alcohol into acetic acid takes place with rapidity. In the same manner wood-spirit, $\text{H,CH}^3\text{O}$, can be converted into formic acid, H,CHO^2 , and amylic alcohol, $\text{H,C}^5\text{H}^{11}\text{O}$, can be converted into valerianic acid, $\text{H,C}^5\text{H}^9\text{O}^2$.

Wine-Vinegar.—The merely sour taste of pure acetic acid is not liked so well with food as the flavour of what is called wine-vinegar, in which, besides the taste of acetic acid, we have that of acetate of ethyl, and probably of some other of the fragrant essences that have been noticed at page 387. Vinegar having a flavour of this kind is prepared in France from sour wines, and it preserves the bouquet of the wines in addition to the flavour of the acetic acid. *White-wine* vinegar and *red-wine* vinegar refer to the description of wines from which the vinegars are prepared.

Malt Vinegar.—Infusion of malt, wines, weak syrup, stale beer, sour cider, and even starch fermented with yeast, yield very good vinegar. In short, all the organised bodies which contain *vinylate* = CH^2O , see page 384, can, by direct or indirect processes, be made to produce acetic acid. The choice of one or the other of these fermentable liquids depends upon local and temporary circumstances, above all things, upon custom-house or excise-office taxation.

To produce vinegar from any of these substances, they should be placed in water, with a little yeast, or a piece of bread soaked in vinegar, to originate the action; and the vessel containing the mixture, loosely covered so as to admit air freely, should be set in a warm place, say at the temperature of 90° or 100° Fah., and after some weeks or months, a quantity of vinegar will be produced. Pure diluted alcohol, secured from air, does not produce vinegar; air is necessary, and also some fermentable substance.

Distilled Vinegar.—Vinegar prepared from fermented liquors contains mucilage and other foreign matters, susceptible of separation by simple distillation. The acid liquor which passes over is called distilled vinegar.

Acetic acid is rather less volatile than water, so that when a diluted acid is distilled, what first goes over is weak acid, and what follows is stronger; but the difference between the boiling points of acetic acid and water is not so great and so definite as to permit of the effective separation of $\text{H,C}^2\text{H}^3\text{O}^2$ from HHO , in the manner that hydrated sulphuric acid can be completely separated from water.

Concentrated Acetic Acid.—Very strong acetic acid can be prepared by distilling the acetates of soda, potash, lead, or copper, with an equivalent proportion of sulphuric acid, diluted with half its bulk of water.

Properties of Acetic Acid.—The hydrated acetic acid = $\text{H}_2\text{C}^2\text{H}^3\text{O}^2$, is very soluble in water. Its concentrated solution has a peculiar pungent odour, and is sufficiently corrosive to blister the skin. It boils at 243° Fah., and distils unchanged. The vapour is combustible, and its combustion produces carbonic acid and water :—

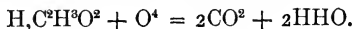

The liquid acid readily crystallises : the strongest acid at 55° Fah ; the weaker acids at lower temperatures.

It is commonly stated in books, that the most concentrated acid has a specific gravity of 1.063 , and that at this density the composition is represented by the formula $\text{H}_2\text{C}^2\text{H}^3\text{O}^2$. Some years ago I made a careful series of experiments on acetic acid, but I did not come to these results. After several crystallisations of the acid, the strongest solution which I could procure, by melting the crystals and carefully raising the solution to 62° Fah., had the specific gravity of 1.0583 , and contained 7162 grains, or 119.375 test-atoms of $\text{H}_2\text{C}^2\text{H}^3\text{O}^2$ in a decigallon. That proportion answers, not to $\text{H}_2\text{C}^2\text{H}^3\text{O}^2$, but to about $8\frac{2}{3}(\text{H}_2\text{C}^2\text{H}^3\text{O}^2) + \text{HHO}$.

As it is possible, by exposing weak vinegar to cold, to freeze water before the hydrated acetic acid freezes, and then, by separating the ice, to strengthen the vinegar, it has been sometimes stated that, in all cases when acetic acid crystallises, the crystals are weaker in acid than the accompanying solution. That, however, is not the case. In the experiment which gave me the strongest acid that I could obtain, the chemical strength of the crystals was $119\frac{1}{3}^\circ$, and that of the mother-liquor was $114\frac{1}{3}^\circ$.

In the Table on the following page I give the results of my experiments on acetic acid.

All the lines in ACETIC ACID, TABLE A, are the results of direct experiments made with great care. But they systematically include the error which results from the assumption, that when acetic acid is made neutral to litmus by the addition of caustic ammonia, the product of such neutralisation is neutral acetate of ammonia. That is an error, because neutral acetate of ammonia is alkaline in its action on litmus. When, therefore, the solution is rendered *apparently neutral*, it contains not only a neutral acetate of ammonia, but also as much free acetic acid as serves to neutralise the apparently basic action of the neutral salt, as shown by its action on litmus. Consequently, every equivalent of ammonia requires for the production of an apparently neutral solution more than an equivalent of acetic acid, and the solutions of acid in this table are all to that extent undervalued. This, perhaps, was the reason why, in testing the crystallisable acid, I did not find the protohydrate.

The methods recommended in some works of testing acetic acid by means of solutions of the carbonates of potash and soda, or by carbonate

ACETIC ACID.—TABLE A.

Test Atom $\text{H}_2\text{C}^2\text{H}^3\text{O}^2 = 60$ Grains. Temperature 62° F.

Specific Gravity of the Acid.	Grains of $\text{H}_2\text{C}^2\text{H}^3\text{O}^2$ in 1 Septem.	Test Atoms of $\text{H}_2\text{C}^2\text{H}^3\text{O}^2$ in 1000 Septems.	Septems containing 1 Test Atom of $\text{H}_2\text{C}^2\text{H}^3\text{O}^2$.	Septems containing 1 lb. of the Acid.	Grains of $\text{H}_2\text{C}^2\text{H}^3\text{O}^2$ in 1 lb. of the Acid.	Money Value of 1 lb. of the Acid.
1.0583	7.162	119.375	8.38	945.9	6767.4	1.000
1.0688	6.75	112.5	8.89	935.6	6315.3	.933
1.0710	6.375	106.25	9.41	933.7	5952.3	.88
1.0737	6.15	102.5	9.76	931.4	5728.1	.846
1.0744	6.	100.	10.	930.8	5584.8	.825
1.0740	5.625	93.75	10.67	931.1	5237.4	.774
1.0733	5.25	87.5	11.43	931.7	4891.4	.723
1.0690	4.5	75.	13.33	935.5	4209.8	.622
1.0638	3.75	62.5	16.	940.	3525.0	.521
1.0564	3.	50.	20.	946.7	2840.1	.420
1.0441	2.25	37.5	26.65	957.9	2155.3	.318
1.0315	1.5	25.	40.	969.5	1454.3	.215
1.0163	.75	12.5	80.	984.	738.0	.109
1.0150	.675	11.25	88.88	985.2	665.0	.098
1.0137	.6	10.	100.	986.5	591.9	.087
1.0121	.525	8.75	114.3	988.	518.7	.077
1.0103	.45	7.5	133.3	989.8	445.4	.066
1.0086	.375	6.25	160.	991.5	371.8	.055
1.0071	.3	5.	200.	993.	297.9	.044
1.0050	.225	3.75	266.7	995.	223.9	.033
1.0034	.15	2.5	400.	996.6	149.5	.022
1.0027	.1125	1.875	533.3	997.	112.2	.017
1.0019	.075	1.25	800.	998.1	74.9	.011
1.0018	.0675	1.125	888.8	998.2	67.4	.010
1.0016	.06	1.	1000.	998.4	59.9	.009
1.0015	.0525	.875	1143.	998.5	52.4	.008
1.0013	.045	.75	1333.	998.7	44.9	.007
1.0011	.0375	.625	1600.	998.9	37.5	.006
1.0009	.03	.5	2000.	999.1	30.0	.004
1.0007	.0225	.375	2667.	999.3	22.5	.003
1.0005	.015	.25	4000.	999.5	15.0	.002
1.0003	.0075	.125	8000.	999.7	7.5	.001

of lime (marble), applied in a lump, do not remedy this inconvenience. But an acetimetrical process has latterly been suggested, which is said to overcome all difficulties. This process is as follows:—

Copper Test for Acetic Acid.—Dissolve sulphate of copper in warm water, and add to the clear solution caustic ammonia very gradually, until the pale-green precipitate which first appears is *very nearly* re-dissolved. I say *very nearly*, because it is necessary that the solution should be *saturated* with oxide of copper, and that saturation is insured by putting into the mixture only so much ammonia as is *not quite enough* to dissolve all the precipitated oxide. The mixture is then to be filtered, and the bright azure-blue solution is to be graduated to a standard.

The constitution of the salt contained in this solution is

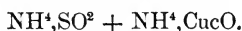

The first substance, sulphate of ammonia, has no action. The cupric ammonia is the true acidimetrical substance. When this compound meets with two atoms of free acid it enters into combination and produces a transparent solution, losing its brilliant blue colour, and acquiring the dull greenish-blue tint proper to a solution of sulphate of copper:

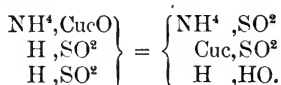

If now, to the solution brought into this neutral state, a single drop of the solution containing NH^4, CucO , is added, this drop acts upon an equivalent quantity of the cupric salt in the liquid, and two equivalents of the hydrated oxide of copper are thrown down:—

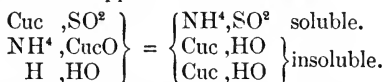

The green precipitate of CucHO which is thus produced is insoluble in the mixed solutions, and its appearance marks the point of *neutrality*.

The solution of cupric ammonia, prepared as directed above, is brought to the strength of 5° , 10° , or any other degree, by the same method as that by which caustic ammonia is prepared of 5° or 10° . See page 108. Standard sulphuric acid of 5° may be used to test it. The test liquor, so adjusted, may be used to test acetic acid, or any other acid which gives a soluble cupric salt. When used for acetic acid, that acid must be diluted, because hydrated cupric oxide is soluble in a strong solution of cupric acetate.

I have not been able to make a series of experiments with this new test, and therefore I retain the comparisons that are given in Table A. The results there shown are correct relatively, though not so, to a small

extent, absolutely, and they accord strictly with the methods of testing in common use.

However, I will give a table of acetic acid (B) in which the relations are independent, not only of the errors due to inaccurate testing, but also of the mistakes that may arise from a wrong comprehension of the value of the specific gravity of the acid, which, as the following paragraph shows, is a point of some importance.

Irregularity of the Specific Gravity of Acetic Acid.—The strongest acetic acid, according to my experiments, has a specific gravity of 1.0583. Its chemical strength is nearly 120°. By dilution with water, the density is increased to about 1.0744, when its chemical strength is 100°. By further dilution the density is constantly diminished; and at a certain point it is again, as at first, 1.0583, at which density its chemical strength is only 53°. It is impossible, therefore, to judge of the chemical or commercial value of acetic acid from its specific gravity. Moreover, even among the dilute specimens of acid, great changes in chemical strength cause but slight changes in density. For solutions of this acid the hydrometer is useless and delusive.

Varieties of Acetic Acid.

Crystallisable Acid.—This acid ought to have the strength shown by the first line in Table A, namely, 119½ test atoms per decigallon. But it is not uncommon to find in commerce acid bearing this name, but possessing not more than one-half or two-thirds of this strength. It ought never to be under 112.

Strong Pyroligneous Acid prepared for the use of Calico-printers.—I have found this acid to be about 37° or 38°.

London Malt Vinegar.—The London malt vinegar, No. 24, corresponding to the old *Excise Proof Vinegar*, should, according to the authorities, possess a strength agreeing very nearly with 7°, or seven test atoms per decigallon. But as the makers are not now under the control of the Excise, there exists little uniformity on this point. Generally, No. 24 agrees more nearly with 6°. The following are the average results of several testings of commercial vinegars which I had occasion to make some time ago:—

No. 16.	.	.	.	3¼ degrees.
17.	.	.	.	5¼ degrees.
18.	.	.	.	4¼ degrees.
22.	.	.	6 to	7¼ degrees.
24.	.	.	5½ to	6 degrees.
Vinegar in mixed pickles				2 degrees.

The reduction of the strength from 7° to 6° is equivalent to a rise of 16 per cent. in price; for Table B shows that 143 gallons of 7° will dilute to 167 gallons of 6°; being an increase of 24 gallons, which is only water.

ACETIC ACID.—TABLE B.

Test Atom $\text{H}_2\text{C}^2\text{H}^3\text{O}^2 = 60$ Grains.

Grains of $\text{H}_2\text{C}^2\text{H}^3\text{O}^2$ in 1 Septem. 1.	Test Atoms of $\text{H}_2\text{C}^2\text{H}^3\text{O}^2$ in 1000 Septems. 2.	Septems containing 1 Test Atom of $\text{H}_2\text{C}^2\text{H}^3\text{O}^2$. 3.	Grains of $\text{H}_2\text{C}^2\text{H}^3\text{O}^2$ in 1 Septem. 1.	Test Atoms of $\text{H}_2\text{C}^2\text{H}^3\text{O}^2$ in 1000 Septems. 2.	Septems containing 1 Test Atom of $\text{H}_2\text{C}^2\text{H}^3\text{O}^2$. 3.
7.2	120.	8.33	2.22	37.	27.
7.14	119.	8.40	2.16	36.	27.8
7.08	118.	8.47	2.1	35.	28.6
7.02	117.	8.55	2.04	34.	29.4
6.96	116.	8.62	1.98	33.	30.3
6.9	115.	8.70	1.92	32.	31.3
6.84	114.	8.77	1.86	31.	32.3
6.78	113.	8.85	1.8	30.	33.3
6.72	112.	8.93	1.5	25.	40.
6.66	111.	9.01	1.2	20.	50.
6.6	110.	9.09	.9	15.	66.7
6.3	105.	9.52	.6	10.	100.
6.24	104.	9.62	.57	9.5	105.
6.18	103.	9.71	.54	9.	111.
6.12	102.	9.8	.51	8.5	118.
6.06	101.	9.9	.48	8.	125.
6.	100.	10.	.45	7.5	133.
5.94	99.	10.1	.42	7.	143.
5.88	98.	10.2	.39	6.5	154.
5.82	97.	10.3	.36	6.	167.
5.76	96.	10.4	.33	5.5	182.
5.7	95.	10.5	.3	5.	200.
5.4	90.	11.1	.27	4.5	222.
4.8	80.	12.5	.24	4.	250.
4.2	70.	14.3	.21	3.5	286.
3.6	60.	16.7	.18	3.	333.
3.	50.	20.	.15	2.5	400.
2.7	45.	22.2	.12	2.0	500.
2.4	40.	25.	.09	1.5	667.
2.34	39.	25.6	.06	1.	1000.
2.28	38.	26.3			

The Adulteration of Vinegar.—The only adulterant of vinegar which is likely to be used extensively is oil of vitriol, because other more volatile acids, nitric and hydrochloric, spoil both the taste and the odour of the vinegar so completely as to render it unsaleable; while diluted oil of vitriol has a pure acid taste and no odour. It will be seen, from the tables of sulphuric acid, that $3\frac{4}{5}$ gallons of oil of vitriol, diluted with water, produce 167 gallons of an acid as strong as vinegar of 60° , which is equivalent to most specimens of commercial (No. 24) that I have examined. Now, $3\frac{4}{5}$ gallons of oil of vitriol of sp. gr. 1.846 weigh about 70 lbs., and would cost a manufacturer about as many pence, so that 167 gallons of diluted sulphuric acid of the strength of vinegar could be made at less than a halfpenny per gallon. If such an acid could be sold as vinegar for a shilling a gallon, it would be a profitable article of commerce. But people will not drink oil of vitriol instead of vinegar if they can help it, and the substitution actually takes place to only a limited extent, though often to an extent that is injurious. I have several times found it to be one-sixth or one-seventh of the whole acid strength of commercial vinegar; sometimes one-tenth; sometimes one-twentieth; rarely less than one-twenty-fifth. The excise allowance was only one of sulphuric acid to one thousand of vinegar.

Quantitative estimation of Sulphuric Acid in Vinegar.—If pure vinegar is diluted with four times its bulk of distilled water, and boiled in a glass beaker or a wide-necked flask, and a dilute solution of nitrate of barytes is added, no precipitate is produced; but if impure vinegar containing sulphuric acid is thus treated, an insoluble precipitate of sulphate of barytes appears in the mixture. Every fresh addition of the solution of barytes produces a fresh proportion of precipitate until all the sulphuric acid is thrown down from the liquor in the state of sulphate of barytes.

Preparation of the test liquor.—Dissolve $65\frac{1}{2}$ grains of dry nitrate of barytes in water, and make with it a decigallon of test liquor at 62° F.

See page 103, for an account of the manipulations. This quantity of nitrate of barytes is equivalent to half a test atom, or $24\frac{1}{2}$ grains, of hydrated sulphuric acid, H_2SO_4 , and as it is diffused in 1000 septems, each septem of it indicates $\cdot 0245$ grain of sulphuric acid.

Process.—Mix 25 septems of the vinegar to be tested with 100 septems of distilled water. Boil the mixture. Add the barytic test from a graduated tube, first a septem, and then other quantities, as apparently demanded, and finally a drop at a time, till the sulphuric acid is entirely removed. As the liquor becomes turbid from the precipitate, it is necessary from time to time to filter a little of it for testing. This is effected by means of the tube filter

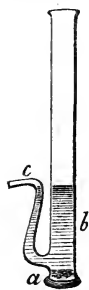

represented by fig. 380. A bit of filtering paper secured by a bit of calico is tied over the end *a*, which end is dipped into the turbid boiling liquor, and when a little clear liquor rises into the tube *b*, it is decanted from the neck *c* into a test-glass, fig. 381, to be there tried with a drop of the test. If there is no precipitate, the action is ended. If there is a precipitate, the mixture is poured back from the test-glass into the beaker, more test liquor is added, and after a little more boiling the filtration and separate testing is repeated.

When the sulphuric acid is entirely precipitated, the number of septems of test liquor that has been used for that purpose, multiplied by $\cdot 0245$, gives the quantity of oil of vitriol expressed in grains, contained in 25 septems of the vinegar thus tested.



Detection of Kreasote in Vinegar.—Sometimes wood vinegar is coloured and sold as wine vinegar. If the wood vinegar has not been thoroughly separated from kreasote it can be easily detected. To that end, the vinegar is to be neutralised with an alkali and then boiled. If kreasote is present, a vapour is given off, the odour of which resembles that of burning wood.

Spontaneous Decomposition of Vinegar.—When vinegar is freely exposed to the air it gradually turns mouldy; the weaker the acid the more rapid is this decomposition. A skin of vegetation appears on the surface, gelatinous lumps fall to the bottom, and in the liquor swim countless infusorial animals. When the decomposition is far advanced, some of these animals in the form of eels are visible to the naked eye. The progress of this spontaneous decomposition of vinegar can be arrested by boiling and filtering it. In common language, vinegar which contains animalculæ is said to be *mothery*.

Testing of Acetic Acid.—As no reliance can be placed upon the indications of the hydrometer, the only method of testing the strength of acetic acid is the chemical method of saturation with an alkali. The best test liquors are caustic potash and caustic ammonia, or, for more precise results, the cupric ammonia test already described. The carbonated alkalis are quite improper, because the disengaged carbonic acid cannot be driven off under a *boiling heat*, and that heat simultaneously drives off as much acetic acid as vitiates the experiment. The best form of alcalimeter is that of Dr. Mohr, represented by fig. 78, page 101. The strength of the test alkalies may be 5° for general use; but it is possible that manufacturers of vinegar may find it handy to have test liquors answering to vinegars of specific numbers, 24, 20, 18, &c. These are easily prepared by the methods described in the general article on Centigrade Testing. The colouring matter of malt vinegar obscures in some degree the action of the liquor on the colour of the litmus; but if the acid to be tested is diluted with three or four times its

volume of distilled water, this difficulty is lessened, and does not prevent the accurate performance of the analysis.

Aromatic Vinegar.—Concentrated acetic acid dissolves several of the essential oils, and acquires a fragrant odour from them. Thus, a few drops of oil of cloves and of cinnamon, dissolved in concentrated acetic acid, produce what is termed aromatic vinegar. The following is a more complex prescription for such a preparation:—Take 360 grains of concentrated acetic acid, 240 grains of acetate of ethyl, 180 grains of absolute alcohol, 45 grains of clove-oil, 30 grains of cedar-oil, 30 grains of lavender-oil, 15 grains of bergamotte-oil, 15 grains of oil of thyme, 7 grains of oil of cinnamon. Dissolve, filter, and preserve in a well-closed bottle. Six or eight drops placed on a hot iron plate scents a large room.

Acetates.—The hydrated acetic acid $\text{H},\text{C}^2\text{H}^3\text{O}^2$ exchanges its basic hydrogen for any other basic radical, and produces salts in accordance with the monobasic formula $\text{M},\text{C}^2\text{H}^3\text{O}^2$. It also produces acid salts, and in some cases the normal acetates combine with a salt on the model of water HHO , and so produce tribasic salts. See page 425.

The acetates are destroyed by heat. Those which contain an alkali or alkaline earth, if rapidly ignited, produce carbonates mixed with charcoal. Acetates that contain easily reducible metals often yield reguline metals and carbon when ignited. Others give protoxides.

When heated with strong sulphuric acid, the acetates all give off acetic acid, easily recognised from its pungent odour. The acetates are nearly all soluble in water and in alcohol. When heated with lime they give off acetone, and when distilled with hydrate of potash they yield marsh gas. When solutions of neutral acetates are mixed with solutions of neutral ferric salts the mixture assumes a deep blood-red colour. Free acids destroy that colour.

The most important acetates are those which are formed with potash, soda, ammonia, barytes, lime, alumina, iron, lead, and copper.

Acetic Anhydride, or Anhydrous Acetic Acid.

Formula, $\text{C}^2\text{H}^3,\text{C}^2\text{H}^3\text{O}^3$; *Equivalent,* 102; *Specific gravity of gas,* 51; *Atomic measure,* 2 volumes; *Specific gravity of liquid at 69° F.* 1.073.

Prepared by distilling three parts of oxychloride of phosphorus with eight parts of anhydrous acetate of potash. A colourless, very mobile liquid of high refracting power. Water and the moisture of the air slowly convert it into hydrated acetic acid:—

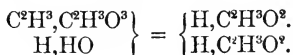

The acetic anhydride forms with acetate of potash a salt which is equivalent in form to the bichromate of potash:—

The Acetate = $2(\text{K}, \text{C}^2\text{H}^3\text{O}^2) + \text{C}^2\text{H}^3, \text{C}^2\text{H}^3\text{O}^3$.

The Chromate = $2(\text{K}, \text{Cr O}^2) + \text{Cr}, \text{CrO}^3$.

Aldehyd.

Formula, $\text{H}, \text{C}^2\text{H}^3\text{O}$; *Equivalent*, 44; *Specific gravity of gas*, 22; *Atomic measure*, 2 volumes; *Specific gravity of liquid at 32°*, 0.8.

Preparation.—Distil in a capacious retort a mixture of 6 parts of oil of vitriol, 4 parts of alcohol of sp. gr. 0.85, 4 parts of water, and 6 parts of peroxide of manganese, in fine powder. Conduct the distilled product into a receiver cooled by ice.

Theory:—

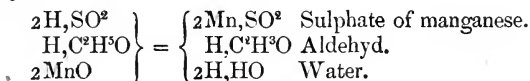

The product so obtained is impure. It must be three times distilled from chloride of calcium. It is then mixed with ether, and saturated with dry ammonia. The product cooled artificially yields crystals of *Aldehyd-ammonium* = $\text{NH}^4, \text{C}^2\text{H}^3\text{O}$. This compound, distilled with oil of vitriol, yields aldehyd. The process demands many precautions.

Aldehyd is a very volatile inflammable liquid, which boils at 70° F. It mixes with water, alcohol, and ether. It has a pungent irritating odour. It is not acid to litmus, but rapidly becomes acid when exposed to air. It has a striking action upon salts of silver, which it reduces so readily that the surface of the glass tube in which the mixed solutions are boiled becomes coated with a brilliant silver mirror. The solutions should have a slight excess of ammonia when boiled. At the same time, aldehydate of silver is formed.

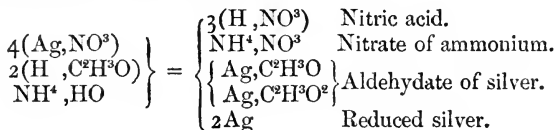

Aldehyd can probably form a variety of salts by exchanging its basic hydrogen for other basic radicals. Besides the salt of ammonium already referred to, a potash salt can be formed by placing metallic potassium in contact with aldehyd. Hydrogen is disengaged, and a salt is formed which dissolves in water and shows alkaline reactions:—

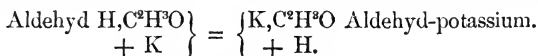

When aldehyd is transmitted over a mixture of lime and hydrate of potash, contained in a heated tube, hydrogen gas is driven off, and acetate of potash is produced:—

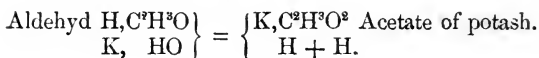

Chloral. Trichloraldehyd.

Formula, H,C²Cl³O; Equivalent, 147.5; Specific gravity of gas, 73.75; Atomic measure, 2 volumes; Specific gravity of liquid, 1.5; Systematic Name, Hydra chlorinic-acetylate.

In this compound, the radical *acetyl* C²H³ is converted by the substitution of chlorine for hydrogen into the vice-radical *chlorinic-acetyl* C²Cl³. In other respects chloral resembles aldehyd. I give this salt as an example of a great range of organic compounds in which the hydrocarbons are changed by the replacement of hydrogen by chlorine, bromine, or iodine, into a new class of compound radicals. See page 413.

Chloral is produced by the action of 8 equivalents of dry chlorine gas transmitted slowly into 1 equivalent of anhydrous alcohol. The products are chloral and hydrochloric acid:—

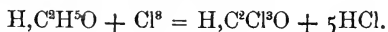

It is a colourless oil of a penetrating odour, which produces a flow of tears. It boils at 201°. Soluble in water, alcohol, and ether.

A solution of potash converts chloral into formiate of potash and chloroform:—



In this decomposition, a radical equivalent to acetyl, C²H³, is split up, while two other radicals are formed, CH, which is formyl, and CCl³, which is equivalent to methyl.

Acetone, CH³,C²H³O. See page 421.

Aldehydic Acid. Lampic Acid.—The composition of lampic acid is

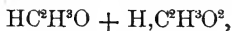

or it is a compound of aldehyd and acetic acid. It is the chief product of the following experiments.

A Wire which instantly becomes red-hot when placed in contact with a Vapour.—Let a few drops of ether be thrown into a cold glass, or a few drops of alcohol into a warm one; let a few coils of platinum wire, of the 60th or 70th part of an inch in thickness, be heated to redness by a spirit-lamp, and when it has ceased to be red-hot, let it be held in the glass over the ether: in some parts of the glass it will become glowing, almost white-hot, and will continue so, as long as a sufficient quantity of vapour and air remain in the glass.

Lamp without Flame.—Take platinum wire, about the 100th of an inch in thickness. Coil it up, and stick the coil loosely on the wick of a spirit-lamp. The cotton of the lamp must be very straight, and not

pressed by the wire. There should be about 16 spiral turns, one half of which should surround the wick, and the rest rise above it. Having lighted the lamp for an instant, on blowing it out, the wire will become brightly ignited, and will continue to glow as long as any alcohol remains.

Another Kind.—Put sulphuric ether into a glass spirit-lamp, and put into the wick-holder the burner figured in the margin. This consists of a cotton wick, *c*, in the centre of which is a narrow glass tube, *b*, to which is fastened a ball of spongy platinum, *a*, such as is represented by fig. 196 at page 204. If the cotton is lighted for a few minutes, and the flame then blown out, the platinum continues red-hot for hours. The combustion of alcohol or ether by this method produces an acid vapour termed lampic acid, or aldehydic acid. This can be collected by placing the head of an alembic over the lamp. If a glass capsule containing *Eau de Cologne* is suspended over the lamp, the perfume will be volatilised by the heat of the ball of platinum.



382.



383.

Aldehydic acid has two replaceable atoms of hydrogen, and is therefore bibasic, consisting of an acetate combined with an aldehyd salt. The production of aldehydate of silver has just been described. If the solution of that salt is filtered, and boiled with hydrate of barytes, it again deposits metallic silver, and the solution then contains neutral acetate of barytes, and neither aldehyd nor aldehydic acid:—

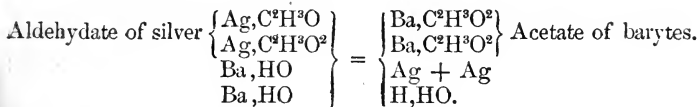

Acetonic Acid.—This acid is commonly said to be bibasic, having the formula $\text{Zn}^2, \text{C}^3\text{H}^{14}\text{O}^6$. But this formula may be reduced to $\text{Zn, C}^4\text{H}^7\text{O}^3$, and the salts are perhaps *acid aldehydates*, $\text{H, C}^2\text{H}^3\text{O} + \text{Zn, C}^2\text{H}^3\text{O}^2$. Acetonic acid is produced by heating a mixture of acetone, hydrochloric acid, hydrocyanic acid, and water:—

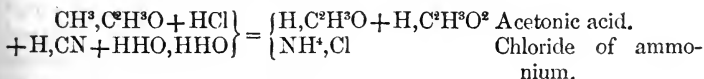

Acetic Oxychloride. $\text{Cl, C}^2\text{H}^3\text{O}$.—Compounds of this form are produced by most of the lower members of the vinyl series of acid radicals, They are very volatile compounds, and each in the state of gas has an atomic measure of two volumes. They are prepared by acting on the hydrated acids with terchloride of phosphorus.

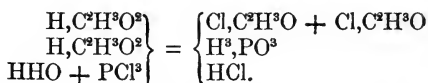

The manipulation is attended with danger to the health of the operator. The compounds are interesting, as having led to the discovery of many of the anhydrides.

With water the oxychlorides suffer sudden and violent decomposition, producing hydrated acid and free hydrochloric acid:—

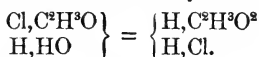

Acetamid. $\text{NH}^2, \text{C}^2\text{H}^3\text{O}$.—Acetamid bears to acetate of ammonia, $\text{NH}^4, \text{C}^2\text{H}^3\text{O}^2$, the same reaction that oxamid bears to oxalate of ammonia. See page 378. It is prepared by decomposing acetate of ethyl by aqueous solution of ammonia under pressure, at 250°F .

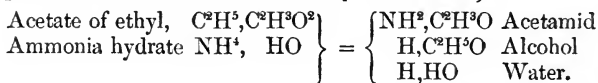

A white, fusible, soluble, crystallisable solid. When boiled with a hydrated alkali, it yields an acetate and free ammonia:—

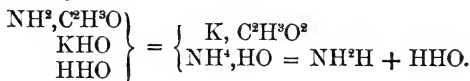

FORMIC ACID.

Formula, $\text{H, CHO}^2 = \text{Hydra formylete}$; *Equivalent*, 46; *Atomic measure in the gaseous state*, 2 volumes; *Specific gravity of gas*, 23; *Specific gravity of the liquid acid*, 1.22.

This acid was first extracted from the poison of the red ant, *Formica rufa*, whence its name. It is also present in the leaves of the stinging-nettle. It can, however, be produced artificially, and it derives importance from its activity and frequency of occurrence and from its containing the simplest of all the compound acid radicals $\text{CH} = \text{formyl}$.

Preparation.—From substances belonging to the Vinylate group, page 384, such as sugar, starch, chaff, bran, sawdust, &c. Mix 1 part of starch, 4 of peroxide of manganese, and 4 of water. Then add gradually 4 parts of sulphuric acid, upon which there occurs an abundant extrication of carbonic acid gas, which causes the mixture to froth up to 8 or 10 times its original bulk. You must therefore use a very capacious retort. When the frothing ceases, the mixture is to be heated, under an arrangement for distillation. There passes over an impure dilute formic acid. That is to be neutralised by dry carbonate of lead, and the resulting formiate of lead is to be purified by crystallisation.

After which, if distilled with an equivalent of sulphuric acid, sulphate of lead is formed, and formic acid distils over.

Theory.—In order to understand how the formic acid is produced in this case, it is necessary to remember that the action of sulphuric acid upon peroxide of manganese is to set free oxygen gas. See page 163. This oxygen gas acts in the nascent state, upon organic substances of the formulæ $C^1 + nCH^2O$. At first the odd atom of carbon goes off as CO^2 , and after that probably some of the vinylate is converted into CO^2 and HHO, since

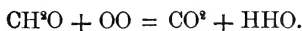

So much is waste; but, at the same time, some of the vinylate is converted into formic acid, by taking up another quantity of oxygen; for $CH^2O + O = H,CHO^2$. In this operation we have an example of the reduction of a natural radical from CH^2 to CH ; but it is possible, though not economical, to produce formic acid by actually constructing the radical formyl by an experimental process.

a). If moistened hydrate of potash is exposed for some time to carbonic oxide gas at the temperature of $212^\circ F.$, the gas is slowly absorbed, and formiate of potash is produced:—

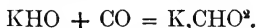

b). The distillation of oxalic acid with sand produces formic acid and carbonic acid:—

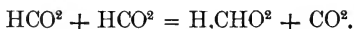

Properties of Formic Acid.—When concentrated, it is a fuming liquid, of an irritating odour; very corrosive; makes painful blisters and sores if dropped upon the skin. Crystallises under $32^\circ F.$ Boils at 222° . The vapour is combustible. The dilute solution is very acid.

Formiates.—Formic acid forms neutral salts by exchanging its hydrogen for basic radicals $H,CHO^2 + NaHO = Na,CHO^2 + HHO$. The salts of Na, Ba, Pb, Cuc are easily crystallisable.

Decompositions.—Formic acid is a powerful reducing agent, and throws down the metals from solutions of Ag, Hgc, Auc, and Pt, disengaging carbonic acid:—

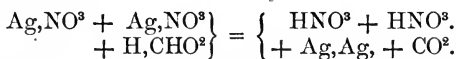

Chlorine converts formic acid into hydrochloric and carbonic acids:—

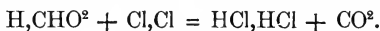

Sulphuric acid decomposes it into water and carbonic oxide:—



LACTIC ACID.

Formula, $H, C^3H^5O^3 = \text{Hydra lactylite}$; *Equivalent*, 90.

Preparation.—Lactic acid is formed when milk turns sour in warm weather. The effect may be imitated by causing milk to ferment by artificial means; also by causing a peculiar species of fermentation, different from the vinous fermentation, to take place in solutions of sugar. Lactic acid is formed in *sauer-kraut*, and in cucumbers and beans pickled with salt; also during the manufacture of wheat-starch, and on many occasions where vegetable and animal substances undergo acidification. It is important to observe, that there exist several organic acids which have radicals that agree with the formula C^3H^5 . It is uncertain whether these radicals are the same or different. The following list shows that this is a subject which demands inquiry:—

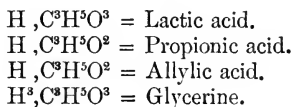

Preparation of Lactic Acid.—Dissolve 8 parts of cane sugar in 50 parts of water; add to the solution 1 part of casein or poor cheese, and 3 parts of chalk. Set the mixture aside for two or three weeks, at the temperature of about 80° F. It will then be gradually filled with crystals of lactate of lime, which may be purified by re-crystallisation. The purified crystals are to be acted on by one-third of their weight of sulphuric acid, which produces sulphate of lime and lactic acid. The latter is soluble in alcohol, and can be separated by that reagent from the sulphate of lime.

Theory.—As the constitution of lactic acid is equal to thrice the constitution of sugar, it is easy to see the possibility of the transmutation which occurs, though not to comprehend exactly how it is effected:—

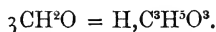

The lime acts by substituting calcium for the basic hydrogen:—

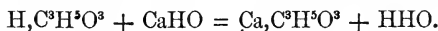

The production of the hydrated acid from the lime salt by the action of sulphuric acid is simply a case of double decomposition:—

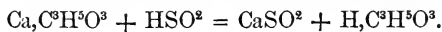

Properties.—A transparent, colourless, inodorous, uncrystallisable, syrupy liquor of sp. gr. 1.21. It has a sharp acid taste, is soluble in

ether and alcohol. Not volatile without alteration in properties and constitution.

Lactates.—Lactic acid forms both neutral and acid salts, such as

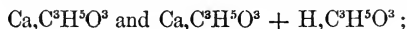

also, basic salts, such as $\text{Cuc,C}^3\text{H}^5\text{O}^3 + \text{Cuc}^3,\text{C}^3\text{H}^5\text{O}^4 = \text{Cuc}^4,(\text{C}^3\text{H}^5)^2\text{O}^7$. This last salt is equivalent in structure to the bibasic phosphates. See page 425.

Lactic Anhydride.—When heated for a long time at 266°F ., lactic acid produces its anhydride:—

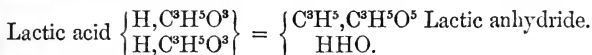

Lactide.—When lactic acid is heated to 500°F ., it produces lactide, citraconic acid, aldehyd, and other products of decomposition—carbonic acid, &c. The relation of lactide to lactic acid is shown in the following equation:—

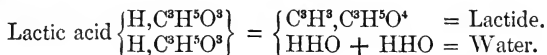

According to this view, lactide is a salt of lactic acid, having an acid radical C^3H^3 acting as a basic radical, and therefore requiring O^4 instead of O^3 . The acid radical C^3H^3 is that which I have described at page 406, as a constituent of citraconic acid, which is also produced in the operation which produces lactide. The composition of citraconic acid is



The composition of aldehyd, also one of the products of this experiment, is $\text{H,C}^2\text{H}^3\text{O}$. Consequently, the decomposition of lactic acid produces in one operation no less than three other radicals, C^3H^3 , C^2H^1 , C^2H^3 .

Lactamid.—Lactide readily absorbs ammonia, and produces lactamid:—

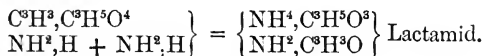

In the product of this operation we have a compound which consists of normal lactate of ammonium in combination with an amidogen salt of the acid $\text{H,C}^3\text{H}^3\text{O}^2$.

Alanine.—The compound so called seems to be the amidogen salt derived from lactate of ammonia. Its composition is $\text{NH}^2,\text{C}^3\text{H}^5\text{O}^2$. When it is treated with nitrous acid, lactic acid is formed and nitrogen set free:—

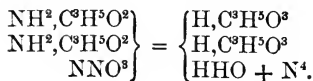

BUTYRIC ACID.

Formula, $H, C^4H^7O^2$ = Hydra butyrylete; *Equivalent*, 88; *Atomic measure in the gaseous state*, 2 volumes; *Specific gravity of gas*, 44; *Specific gravity of liquid at 32 F.* .99.

Preparation.—Prepare lactate of lime, as described at page 450. Then add water to supply the loss occasioned by evaporation, and raise the heat to 90° F. The lactate of lime will disappear, the mixture will become liquid, and butyrate of lime will be formed. The mass is filtered warm through a cloth. The butyrate of lime crystallises when the solution cools. This salt is dissolved in water, and treated with carbonate of soda, which produces soluble butyrate of soda and insoluble carbonate of lime. The solution of butyrate of soda is mixed with an excess of diluted sulphuric acid, upon which the greater part of the butyric acid rises to the surface of the liquor in the state of an oil.

Properties.—Hydrated butyric acid is a colourless liquid, which volatilises at mean temperature with a strong odour of rancid butter. It has a sharp acrid taste. It is soluble in water, ether, and alcohol. At about 320° it distils unchanged.

Butyrates.—This acid is monobasic, and the salts agree with the formula of the acid given above. The chief metallic salts are those with Ba, Ca, Zn, Pb, Hg, and Ag.

Butyric Anhydride.—When the butyrate of soda is distilled with chloride of benzoyle, the butyric anhydride is produced. This is a colourless, very mobile liquor, having the odour of the pine-apple. Its formula is $C^4H^7, C^4H^7O^3$. It forms a gas, having the specific gravity of 79, and an atomic measure of 2 volumes. When exposed to moist air, it acquires the rancid odour of the hydrated acid, to which state it returns.

Glycollate of Butyryl.—The radical of butyric acid combines in three proportions with glycerine to produce the following salts:—

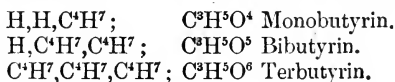

These compounds, mixed with various tasteless and inodorous fats, constitute butter.

Butyric Ether. $C^2H^5, C^4H^7O^2$.—This is a butyrate in which ethyl is the basic radical. It is a fragrant ether, and seems to form the chief part of the flavouring matter of the pine-apple, melon, strawberry, and other fruits. The presence of a little of this ether gives to rum the flavour known as that of pine-apple rum.

Butyramid. NH^2, C^4H^7O .—Produced when butyric ether is heated in close vessels with ammonia. Thus:—

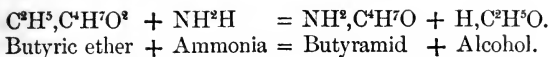

Soluble, volatile, fusible.

VALERIANIC ACID.

Formula, $\text{H}, \text{C}^5\text{H}^9\text{O}^2 = \text{Hydra valerylete}$; *Equivalent*, 102; *Atomic measure in the state of gas*, 2 volumes; *Specific gravity of gas*, 51; *Specific gravity of liquid*, 0.937.

The radical valeryl occurs, in some state of combination, in the root of the plant valerian, in the berries of the guelder-rose, and in some descriptions of train oil. It occurs among the products of the oxidation of fat oils and other organic substances.

Preparation.—Distil fusel oil (amylic alcohol = $\text{H}, \text{C}^5\text{H}^{11}\text{O}$) with a mixture of dilute sulphuric acid and bichromate of potash. Valerianic acid mixed with valerianate of amyl passes over, and the latter can be decomposed by caustic potash into valerianate of potash and fusel oil. The valerianate of potash, when distilled with sulphuric acid, furnishes pure hydrated valerianic acid.

Theory.—These operations are rather complex, and require elucidation. The mixture of sulphuric acid and bichromate of potash gives off oxygen, which acts upon the fusel oil:—

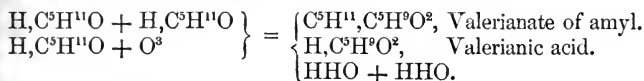

Two atoms of amyl C^5H^{11} , lose each H^2 , and become valeryl C^5H^9 . The oxygen serves, in the first place, to carry off the displaced hydrogen, and, in the second place, to convert the aldehyd of valeryl into valerianic acid. The decomposition of valerianate of amyl by caustic potash may be represented thus:—

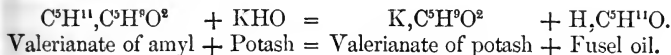

Properties of Valerianic Acid.—A limpid colourless oil, having a powerful odour of valerian root, and a burning taste. Partially soluble in water; soluble in alcohol and ether. Boils at 347° , and produces a gas of spec. grav. 51.

Valerianates.—The salts have a fatty aspect. They are soluble, and have a sweetish taste. When dry, without odour. If warmed with sulphuric acid, they produce the peculiar odour of valerianic acid.

Valeric Anhydride, $\text{C}^5\text{H}^9, \text{C}^5\text{H}^9\text{O}^3$.—A colourless mobile oil, having the agreeable odour of apples. It gives a gas, having an atomic measure of two volumes. Alcalies with water convert it into hydrated valerianic acid.

Valerianate of Ethyl, $C^2H^5, C^5H^9O^2$.—Valerianic ether. Fragrant, resembles the odour of some fruits.

Valerianate of Amyl, $C^5H^{11}, C^5H^9O^2$.—A fragrant ether, possessing the peculiar flavour of apples, particularly of rennets.

Valeramid, NH^2, C^5H^9O .—Forms large crystals. Prepared by the action of ammonia on valerianate of ethyl:—

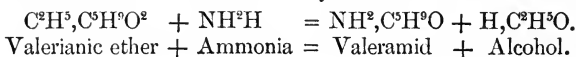

ON FATS, OILS, AND SOAPS.

Fats and oils are produced in abundance both by plants and animals. The suet, or hard fat of mutton, the softer fat of beef, and the lard, or very soft fat of pork and goose, are known to all. The fats and oils of plants are chiefly found in the seeds. Those of the *cruciferae* yield a large quantity of oil, especially rapeseed and linseed. The fruit of the olive, and that of the palm-oil fruit, also give oil in abundance.

When these fats and oils are separated from albuminous matters, they are found to consist of a variety of substances in apparent mixture. Among these substances, three occur so frequently, and in such large quantities in proportion to the others, that they require prominent notice. These three substances are stearin, margarin, and olein. Stearin is the chief part of suet, and is solid at mean temperature. Olein is the chief substance in oils that are liquid at mean temperature. Margarin is also solid at mean temperature, but less hard than stearin. It is distinguished by a pearly aspect. When these substances are mixed together, the fat is hard or soft according as stearin or olein predominates.

The general nature of these fats has been explained in the article on the Glycerides at page 428. They are all salts of glycylic acid, $HHH, C^3H^5O^3$; and, according to circumstances, each salt contains one, two, or three atoms of the radical peculiar to it, and there are, consequently, three varieties of each kind of fat, as,

Monostearin, bistearin, terstearin.
Monolein, biolein, terolein, &c.

And as a considerable number of fatty radicals are known, a considerable number of fats must necessarily spring from them. See page 429.

The fats and oils are lighter than water. They are soluble in ether and to some extent in alcohol; so are they also in oil of turpentine and in benzole, and they mix with one another in all proportions. They make a semitransparent stain upon paper. They may be heated to about 500° F. without much change, but they cannot be distilled without undergoing decomposition. At 500° F. they give off' offensive

vapours, and at 600° F. they decompose and evolve gaseous hydrocarbons and a variety of solid and liquid fatty acids, each of which contains a radical peculiar to itself.

When the glycerides, or fats, are decomposed, and the glycerine, or glycylic acid, is separated, the fatty radicals individually produce monobasic hydrated acids. Thus:—

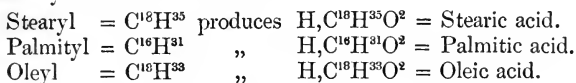

These acids can in all cases exchange their basic hydrogen for metallic radicals, and so produce neutral salts. These salts are the substances which are commonly called SOAPS, and which, when the basic radicals are potassium or sodium, are salts that are soluble in water. I have explained at page 430 the manner in which glycerine can be separated from the fats by means of caustic alkali, which serves to bring the fatty radicals into the condition of acids.

The fatty acids can be separated from the alkaline metals as follows:—Dissolve the soap in water, and add hydrochloric acid. This converts the metal into a soluble chloride, and supplies basic hydrogen to the fatty acid:—

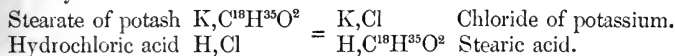

Unctuous flocculi appear in the liquor. If heat is applied, these flocculi melt and produce a layer of oil on the surface of the water. When cold, this substance is found to have properties that differ from those of the original fat, the stearin. The fat is crystalline and soluble in alcohol. Its solution reddens litmus. It also dissolves readily and completely in a hot solution of caustic alkali, the liquor, of course, being a solution of soap.

The fatty radicals can, therefore, act as acid radicals against hydrogen or metals, forming neutral salts with two atoms of oxygen; and they can act as basic radicals, one, two, or three equivalents at once, against the terbasic glycylic acid or glycerine, provided that each radical thus acting as a basic radical is provided, according to the general rule set forth at page 296, with one additional atom of oxygen.

Glycerine, therefore, is the governing principle of the neutral fats, whether natural or artificial, HHH ; $\text{C}^3\text{H}^5\text{O}^3$. Its three atoms of basic hydrogen HHH are separately or collectively replaceable by any of the fatty radicals if aided by additional oxidation. These fatty radicals can in their turn be displaced from glycerine by other atoms of hydrogen, the terbasic glycylic acid being restored to its acid condition, and the fatty radicals being simultaneously converted into hydrated acids. The formulæ quoted in the article on the Glycerides, pages 428 to 430, exhibit these transmutations with satisfactory clearness.

Special Oils and Fats.

Olive Oil.—Expressed from ripe olives. Its solid ingredient is margarin. Sp. gr. .918. *Almond Oil*.—From almonds. Sp. gr. .918. *Colza Oil*.—From the seeds of the *brassica oleifera*. Sp. gr. .913. It becomes nearly solid at 22° F.

Linseed Oil.—From linseed. Sp. gr. .939. It has powerful drying properties, and is for that reason an important ingredient in inks, paints, and varnishes.

Sperm Oil.—The liquid part of the fat of the spermaceti whale. Sp. gr. .858. It consists of margarin and olein, but owes its odour to a volatile acid, which resembles valerianic acid. Common *Whale Oil* has the sp. gr. .927, and a darker colour and worse odour than sperm oil.

Cod-liver Oil.—Extracted from the liver of the common cod fish. Sp. gr. .928. Taste and odour fishy. Its composition is more complex than that of the other fish oils. It contains acetin, and some compounds of iodine, bromine, and phosphorus. It is extensively employed as a medicine.

Castor Oil.—From the seeds of the *Ricinus communis*. Sp. gr. .969. Differs from other fixed oils by being soluble in alcohol. It yields oleic acid, and, when distilled, a number of other substances, such as œnanthylic acid and œnanthylic aldehyd. Distilled with potash, it produces octylic alcohol, $H, C^8 H^{17} O$.

The Solid Fats.

The solid fats derived from plants are cocoa-nut oil, nutmeg butter, and palm oil. Those from animals are butter, suet, lard, spermaceti, and beeswax.

Cocoa-nut Oil.—Used for making candles and for marine soap. A complex fat, which, on saponification, yields at least six of the acids named between the Caproic, No. 36, and the Palmitic, No. 46, in the list of Vinic Acids, page 402.

Palm Oil.—From the pulp of the ripe fruit of the *Elais guineensis*. It has a golden yellow colour, and, when not rancid, an odour resembling that of violets. The solid portion consists of palmitin, which yields palmitic acid, No. 46. It speedily turns rancid, owing to decomposition, produced by azotised bodies extracted from the fruit in company with the oil. The yellow colour can be destroyed by the oxidising action of chromic acid, applied in the state of a mixture of sulphuric acid and bichromate of potash. Twenty thousand tons of palm oil are imported annually, chiefly for conversion into candles and soap.

Butter consists of several fats, of which palmitin is the chief. It contains more or less olein, according to its hardness, and its flavouring constituents are butyryn, caproin, and caprylin. When these fats are

saponified, they produce all the following acids:—Glycylic acid or glycerine, and palmitic, oleic, butyric, caproic, and caprylic acids.

The knowledge of these facts gives rise to a curious speculation. It may hereafter happen to be possible for chemists to prepare the butyric and other volatile acids of the lower order of the vinyl series from cheap materials; and as it is possible to procure palmitin and olein from abundant sources, such as palm oil and olive oil, it would become a question whether, by mixing these ingredients in suitable proportions, we could not manufacture artificial butter. This does not appear to be more improbable than the manufacture of artificial sugar from starch or linen rags, which has been accomplished, though not for economical purposes.

Lard.—The soft fat of pigs, in which olein is more abundant than margarin and stearin. *Suet*.—The solid part is principally stearin. When melted it is called tallow.

Spermaceti.—*Formula*, $C^{16}H^{33}, C^{16}H^{31}O^2 =$ Cetyla palmitylete. The palmitate of cetyl. Cetin. Pure spermaceti.

Spermaceti is a solid fat, extracted from the brain of the spermaceti whale, in which it is accompanied by liquid sperm oil. It differs from common fats in containing no glycerine. When saponified, it yields a base that has been called Ethal. This saponification is simply a case of double decomposition:—

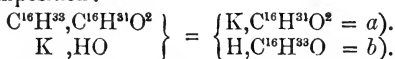

The substance *a*) is the palmitate of potash. The substance *b*) is ethal, an alcohol of the base cetyl. See No. 16 of the Basic Radicals, page 401.

Spermaceti fuses at 120° F., and solidifies to a silky translucent fat of delicate whiteness. Sp. gr. .94. Insoluble in cold alcohol of sp. gr. .816. Soluble in hot absolute alcohol and in hot ether. Crystallises when the solution cools.

Beeswax.—Beeswax contains, or at least yields, under the gentle compulsion of chemical decomposition, a variety of compounds, which are composed of the higher radicals of the two vinyl groups, such as—

Cerotic acid, <i>Cerin</i>	H, $C^{27}H^{59}O^2$	Hydra cerotylete.
Cerylic alcohol, <i>Cerotin</i>	H, $C^{27}H^{55}O$	Hydra cerylate.
Chinese wax	$C^{27}H^{55}, C^{27}H^{53}O^2$	Ceryla cerotylete.
Cerene	H, $C^{27}H^{53}$	Hydra cerotyla.
Melissin, Melissic alcohol	H, $C^{30}H^{61}O$	Hydra myricylate.
Melissic acid	H, $C^{30}H^{59}O^2$	Hydra melissylete.
Palmitic acid	H, $C^{16}H^{31}O^2$	Hydra palmitylete.
Myricin	$C^{30}H^{61}, C^{16}H^{31}O^2$	Myricyla palmitylete.
Melene	H, $C^{30}H^{59}O$	Hydra melissylate.

I have added in the last column the names that are supplied to these complex compounds by the systematic nomenclature explained in this work.

I pass over the description of these compounds and the methods of procuring them from beeswax. Particulars will be found in papers by Professor Brodie, printed in the "Philosophical Transactions" for 1848-1849.

SOAP-MAKING.—If water and oils or melted fats are mixed together, they do not combine to form a compound, but spontaneously separate when left at rest. But if a solution of caustic soda is shaken with the mixture, the whole combine together, and produce a white mixture, which is a species of soap. If more soda is added, and the mixture is boiled for some hours, it becomes transparent, and shows all the characters of a strong solution of soap. If this clear liquor is mixed with a strong solution of common salt, a curdling is produced, and the mixture exhibits a clear solution, and a solid granular substance, which rises to its surface. The clear solution contains common salt and the glycerine or glycolic acid, which has been separated from the fat by the soda. The solid matter, if drained, pressed together, and dried, is Soap.

These experiments are fully explained by the preceding details, and by the theory of the Glycerides, inserted at page 428. The fats, which do not dissolve in water, are glycerides. They are decomposed by caustic alkali (see page 430); glycerine is separated, and salts of soda, with the fatty acids derived from stearin, palmitin, margaric, olein, &c., are formed in the solution. These soda salts are soaps, which are soluble in water, but not soluble in a strong solution of common salt, in consequence of which the addition of brine to a solution of soap causes it to separate in the solid form.

Varieties of Soap.—Hard soaps contain soda; soft soaps contain potash. Soaps which contain lime or other earths are insoluble in water. Hence the addition of soap to water which contains bicarbonate of lime produces a curdling, which curdling is caused by the insoluble salt formed by lime with the fatty acid:—

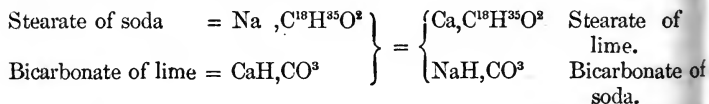

The fatty materials commonly used for hard soaps are tallow, palm oil, kitchen stuff, and rosin; and for soft soaps, fish oils and hempseed oil. Yellow soap is made from rosin, tallow, and palm oil. Mottled soap from tallow, palm oil, and kitchen stuff. Curd soap from tallow.

CANDLE-MAKING.—The pure fatty acids are, at mean temperature, whiter, harder, more cleanly, and more suitable for combustion than the various glycerides from which they are derived. Consequently, the best sort of candles, improperly called stearin candles, do not consist of stearin, but of the stearic acid, procured from stearin by a process of saponification. In the manufacture of candles there are to be considered

the kinds of fat, and the conversion of these from the state of glycerides into the state of fatty acids. The best processes for the reduction of the glycerides are these:—1. Saponification by means of lime. 2. By the action of oil of vitriol. 3. The separation of fats into glycerine and fatty acids by water applied under pressure at high temperatures. I cannot enter into details on these subjects.

STEARIC ACID.

Formula, $H, C^{18}H^{35}O^2 =$ Hydra stearylete; *Equivalent*, 284.

Preparation.—Saponify mutton suet with caustic soda, and decompose the hot solution of the soap with tartaric acid. Press the solid fat between hot plates, which squeezes out a quantity of oleic acid. The solid residue is to be dissolved and crystallised from alcohol several times, and afterwards from ether, until the fusing point of the acid is 159° . The solution in ether, on cooling, deposits crystalline plates. When fused, it forms a colourless, tasteless, inodorous oil, which, on cooling, forms a white crystalline mass. It is insoluble in water, but soluble in hot alcohol, and the solution reddens litmus.

Stearates.—Stearate of soda, $Na, C^{18}H^{35}O^2$, is the basis of ordinary hard soap. It is soluble in water, but not in brine, and advantage is taken of this property to separate soda soap from glycerine. The stearates of the earths are insoluble.

When stearic acid is boiled for some days with nitric acid, it produces—

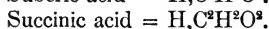
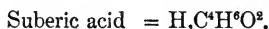

The former used to be the *acid of cork*, and the latter the *acid of amber*, having been originally procured from those substances. It was little anticipated at that time that both these acids could be easily procured from tallow.

MARGARIC ACID.

Formula, $H, C^{17}H^{33}O^2 =$ Hydra margarylete; *Equivalent*, 270.

The existence of this acid has been denied by Heintz, who considers it to be a mixture of stearic and palmitic acids. But the series of acid radicals, Group B, page 402, shows the probable existence of the radical $C^{17}H^{33}$; and as we know a process (see page 460) by which oleic acid, $H, C^{18}H^{33}O^2$, can be converted into palmitic acid, $H, C^{16}H^{31}O^2$, it is easy to conceive how it may be possible to convert margaric acid experimentally into stearic and palmitic acid, although those two acids may not exist ready-formed in the margaric acid:—

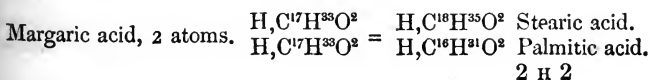

Preparation of Margaric Acid.—Dissolve Marseilles, or olive-oil soap, in boiling water, and add a solution of chloride of calcium. A precipitate is formed, which is to be dried, pulverised, and digested in cold ether. What dissolves in the cold ether is oleate of lime. What remains undissolved is margarate of lime. Decompose this margarate by boiling it with hydrochloric acid:—

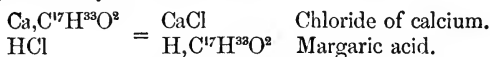

The margaric acid appears in the hot acid liquor as an oil. It is to be thoroughly washed and crystallised from alcohol. When purified, it is a white solid, which fuses at 140° F. It has distinct acid properties, and forms neutral salts or perfect soaps with potash and soda. These salts crystallise in pearly scales. Margarine, or the glyceride of margaryl, occurs in mixture with olein, in the soft fats, such as goose fat, butter, &c.

PALMITIC ACID.

Formula, $\text{H,C}^{16}\text{H}^{31}\text{O}^2$ = Hydra palmitylete; *Equivalent*, 256.

Palmitic acid is prepared by saponification from palm oil, in which it exists in the condition of palmitin. When palm oil has been long kept, it undergoes spontaneous decomposition; and in that case the solid portion, or palmitin, is accompanied by a large quantity of free palmitic acid, $\text{H,C}^{16}\text{H}^{31}\text{O}^2$, while the liquid portion, or oil, contains a considerable proportion of uncombined glycerine, $\text{HHH,C}^3\text{H}^5\text{O}^3$. Palmitic acid can also be procured from spermaceti, human fat, the solid part of olive oil, and from margarin and olein. When oleic acid is fused with caustic potash, the decomposition takes place as follows:—

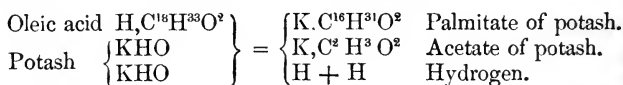

Palmitic acid, when purified by crystallisation from alcohol, is a tasteless white fat, fusible at 144° , and volatile without decomposition. The neutral palmitates of the alcalies are soluble in hot water, which produces a jelly on cooling. They can be crystallised from a solution in boiling alcohol.

OLEIC ACID.

Formula, $\text{H,C}^{18}\text{H}^{33}\text{O}^2$ = Hydra oleylete; *Equivalent*, 282.

Preparation.—The preceding details show that oleic acid can readily be procured in large quantities; but as it has a great tendency to combine with oxygen, it is rather difficult to obtain it pure. The best process is as follows:—Saponify almond oil by potash; decompose with an acid. Digest the mixed fatty acids thus set free with half the

weight of oxide of lead. This produces mixed salts of lead. Digest in ether, which dissolves the acid oleate of lead, and leaves the margarate and stearate of lead undissolved. The clear solution of oleate of lead in ether is mixed with hydrochloric acid, which precipitates chloride of lead, and leaves oleic acid in solution. The ether is distilled off, and the free acid remains. It is impure and of a brown colour. Expose it to cold, upon which the pure acid crystallises, and is to be freed from the liquid impurities by pressure. If that purification is not sufficient, the oleic acid can be converted by barytic water into oleate of barytes, which is to be purified by solution in alcohol, and the purified salt is to be decomposed by sulphuric acid.

Pure oleic acid is a liquid at above 57° F. Colourless, inodorous, tasteless, and without action on litmus; but in the air it rapidly absorbs oxygen, turns brown, acquires a rancid odour, and reddens litmus, showing the commencement of decomposition. When liquid, it does not solidify till cooled to 40° ; when solid, it does not melt till heated to 57° . When heated strongly, it is decomposed, not being capable of distillation unchanged. Among the products of its decomposition by distillation are several acids of Group B, especially the acetic, caproic, and caprylic acids, but the chief product is sebacic acid, No. 65, Group C. A large quantity of hydrocarbons in the state of gas is also given off.

Oleates.—The oleates have the character of soaps or of plasters, according as they are soluble or insoluble in water. Oleate of potash is a soft soap, forming the chief ingredient in Naples soap. Oleate of soda is a hard soap, and forms a part of Marseilles soap.

Impure oleic acid is the oily liquid that is expressed from masses of stearic or other solid fatty acids after saponification by lime in the process of candle-making.

Metamorphoses of the Radicals of the Fatty Acids by the action of Nitric Acid.

I have shown that hydrated sulphuric acid and hydrochloric acid are employed in various processes with fatty acids and their salts, as agents of double decomposition, and that they do not act destructively upon the radicals of these acids. The case is far different with nitric acid, which, when made to act upon the fatty acids, splits up their complex radicals into many radicals of simpler forms. Thus when oleic acid is treated with nitric acid of sp. gr. 1.23, in a large retort, a violent action occurs, much peroxide of nitrogen is expelled, and two classes of acids are produced—volatile acids, which distil over into the receiver, and fixed acids, which remain in the retort. The relative quantities of the two classes of acids depend upon the degree of concentration of the nitric acid. When that acid is strong, the volatile acids are most abundant; when it is weak, the fixed acids are most abundant.

The volatile acids thus produced belong to the vinyl series, Group B, page 402, and include all those from the acetic to the rucic, Nos. 32 to 40. The fixed acids belong to Group C, page 404, and include the adipic, suberic, sebacic, and pimelic acids.

In the same manner Chinese wax, $C^{27}H^{55}, C^{27}H^{53}O^2$, when distilled with strong nitric acid, splits up into a variety of acids, which contain radicals both of the vinyl and the succinyl group, among which the following are found:—

Oenanthylic acid	}	Belonging to Group B.
Butyric acid		
Caprylic acid		
Anchoic acid	}	Belonging to Group C.
Suberic acid		
Pimelic acid		

These remarkable results are not difficult of comprehension. The radicals of the vinyl series are converted into those of the succinyl series by loss of hydrogen, which is taken up by the oxygen of the nitric acid; while, on the contrary, the radicals of the succinyl series are converted by heat, under loss of carbon, which goes off as carbonic acid, into acids of the vinyl series. When, therefore, any acid which contains a complex radical of the vinyl series is heated with nitric acid, various members of both these series of radicals, all less complex in structure than the radical that is operated upon, always appear among the products of the decomposition.

Examples of the Transmutation of Radicals by Oxygen.

a). Hydrogen driven off in the state of water:—

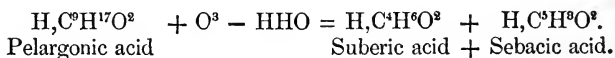
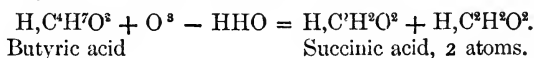

b). Carbon driven off in the state of carbonic acid:—

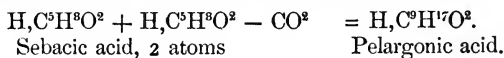

Theoretically, it is possible that all the radicals of those two groups are thus reciprocally convertible the one into the other; so that any effect of this kind which appears in our experiments may be accepted as matter of course. But to what extent the transmutations can be experimentally performed I do not know.

SUCCINIC ACID.

Formula, $\text{H}_2\text{C}^2\text{H}^2\text{O}^2 = \text{Hydra succinylete}$; *Equivalent*, 59. *The atomic measure of succinic acid in the state of gas is unknown. The atomic measure of the radical succinyl, C^2H^2 , in neutral salts is nothing.*

Succinic acid was originally obtained from amber by dry distillation. It is easily formed artificially by acting at a boiling heat for some days upon palmitic or stearic acid with nitric acid. It is also obtainable by fermentation from asparagin and from malic acid. The comparison of malic acid with succinic acid,

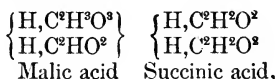

shows that, apparently, only a slight action is necessary to insure the conversion of the one into the other; but, in practice, the change is not effected so simply. There is a discharge of carbonic acid and sometimes of hydrogen; and the products, if we act upon malate of lime, are not only succinate of lime, but carbonate, acetate, lactate, and butyrate of lime, with a small quantity of an essential oil, which has an agreeable odour of apples, and which is probably the butyrate of methyl. Here, therefore, we have other examples of the building up or breaking down of organic radicals by the energy of the nascent oxygen supplied by decomposed nitric acid, or by the process of fermentation.

Succinic acid is a very stable salt. It forms crystals, which dissolve in two parts of boiling water or five parts of cold water. It fuses at about 350°F . If suddenly heated to 455° , it melts, boils, and sublimes under partial conversion into the succinic anhydride. If the sublimed acid is distilled with anhydrous phosphoric acid, the succinic anhydride, $\text{C}^2\text{H}^2\text{C}^2\text{H}^2\text{O}^3$, is obtained pure.

Succinates.—There are three kinds—monobasic salts, double salts, and quadruple salts. They are characterised by the brown bulky precipitate which their solutions give with solutions of ferric salts.

TARTARIC ACID.

Formula, $\text{H}_2\text{C}^2\text{H}^2\text{O}^3 = \text{Hydra tartrylite}$; *Equivalent*, 75.

Tartaric acid occurs chiefly in the juice of the grape; it is also found in the tamarind and in the unripe berries of the mountain ash. It passes from grape-juice into the wine that is made from grapes, and is deposited in the wine-casks in the form of a crust, which is commonly called tartar, crude tartar, or argol, the chemical composition of which is represented by the formula $\text{K}_2\text{C}^2\text{H}^2\text{O}^3 + \text{H}_2\text{C}^2\text{H}^2\text{O}^3$, which formula signifies that this salt is the bitartrate of potash, or a compound of hydrated tartaric acid with neutral tartrate of potash.

Preparation.—Dissolve crude tartar in boiling water, and add powdered chalk as long as it produces effervescence: four parts of tartar require about one part of chalk. Tartrate of lime is precipitated, and neutral tartrate of potash remains in solution. This double decomposition may be formulated thus:—

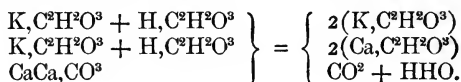

Add a solution of chloride of calcium to the tartrate of potash in solution, in an equivalent quantity. The rest of the tartaric acid is thus converted into tartrate of lime:—

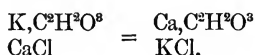

The precipitated tartrate of lime is well washed, and digested with dilute sulphuric acid, in quantity sufficient to combine with all the lime. Double decomposition again takes place, and the products are insoluble sulphate of lime and soluble tartaric acid:—

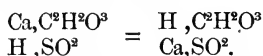

When the operation is completed and the liquor cooled, it is filtered, evaporated to the consistence of syrup, and crystallised. The formation of the crystals, though not the purity of the acid, is favoured by the presence of an excess of sulphuric acid.

Properties.—Well-formed crystals, consisting of hemihedral forms of the oblique rhombic system. When pure, colourless, transparent, and permanent in the air. Soluble in water, alcohol, and wood spirit. It has a sharp, agreeable, acid taste, and is for that reason much used, instead of the more expensive citric acid, for the preparation of acid effervescing beverages. When gently heated, the crystals become strongly electrical. There are several varieties of tartaric acid, which differ remarkably in their relations to polarized light, but I have no space to enter upon a description of them.

Tartrates.—Tartaric acid exchanges its basic hydrogen for any other basic radical, and produces an extensive series of neutral salts. It also forms a variety of multiple salts, such as,

Terbasic Tartrates:—

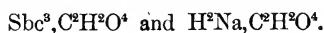

Acid Tartrates:—



Double Tartrates:—

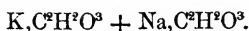

Conjugated Tartrates :—

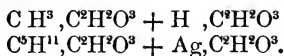

Tetrabasic Tartrates :—

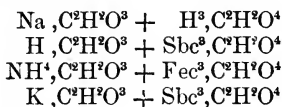

Complex Tartrates :—

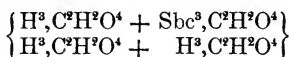

For a complete investigation into the constitution of the tartrates, the reader is referred to my work on the Radical Theory, page 461.

An aqueous solution of tartaric acid becomes mouldy if kept long. When used as a reagent it should be freshly prepared, and it should be kept in stock in crystals, not in solution.

If a solution of tartaric acid is added to a solution of caustic potash till the mixture is neutral to litmus, the salt produced is neutral tartrate of potash, which is easily soluble in water. If an additional equivalent of tartaric acid is then added, it produces bitartrate of potash, which is somewhat difficult of solution, and, therefore, occasions the gradual formation of a crystalline precipitate.

CITRIC ACID.

Formula as a tribasic acid = HHH ; C⁶H⁵O⁷. *Formula as a triple acid* = H, C²H³O³ + H, C²HO² + H, C²HO². *Formula of the commercial acid in crystals* = HHH ; C⁶H⁵O⁷ + Aq. *Equivalent, in crystals*, 210 ; *dry*, 192.

I have briefly explained my views of the constitution of the citrates at pages 405 and 427, and more fully in my special treatise on the Radical Theory, page 424, where I have cited the facts which seem to prove that citric acid is a triple acid, and not a tribasic acid.

Citric acid occurs chiefly in the citron, the lemon, the orange, and other fruits of that tribe. It is also found in gooseberries, raspberries, strawberries, cherries, currants, and tamarinds, often in company with malic acid.

Preparation.—The expressed juice of the citron or lemon is neutralised with chalk, and the insoluble citrate of lime is decomposed by sulphuric acid. The process is similar to that by which tartaric acid is prepared. It is finally obtained in crystals. These are very soluble in water, and the solution has an agreeable acid-taste. When the cold saturated aqueous solution is allowed to evaporate spontaneously, it forms trans-

parent colourless rhombic prisms, which constitute the crystallised commercial acid. A diluted solution of the acid gradually becomes mouldy and decomposes, showing acetic acid among the products of decomposition. When heated with an excess of sulphuric acid, citric acid produces acetic acid, carbonic oxide, and carbonic acid:—

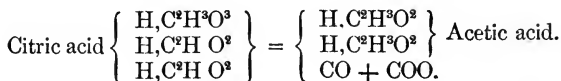

With nitric acid it produces acetic, oxalic, and carbonic acids. With hydrate of potash it forms oxalate and acetate of potash:—

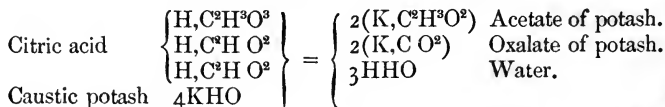

When citric acid is heated it produces aconitic acid, $\text{H, C}^2\text{HO}^2$ (see page 427), which occurs naturally in the plants called monk's-hood (*aconitum*) and mare's-tail (*equisetum*), and also disengages water, carbonic acid, carbonic oxide, and acetone = $\text{CH}^3, \text{C}^2\text{H}^3\text{O}$. When more strongly heated, citric acid produces citraconic acid = $\text{H, C}^3\text{H}^3\text{O}^3 + \text{H, C}^2\text{HO}^2$. See page 406.

These reactions make it probable that citric acid contains not only the radical dyl or aconyl C^2H , but also the radical acetyl = C^2H^3 , and that the difference between acetic acid, $\text{H, C}^2\text{H}^3\text{O}^2$, which does not seem to exist ready-formed in vegetable juices, and the acid $\text{H, C}^2\text{H}^3\text{O}^3$, which appears to abound in them, and is readily convertible into acetic acid, is simply a difference in the amount of oxidation.

Citric acid is extensively used by calico-printers and silk-dyers. Lemon-juice is a valuable anti-scorbutic article of diet.

Citrates.—The three acids, which collectively constitute citric acid, contain one replaceable atom of basic hydrogen in each, and as replacement of this hydrogen by other basic radicals, metallic, azotic, or compound, can take place, either collectively or separately, it follows that a very great variety of citrates are produceable, and that, according as the replacement is effected on one, or two, or three atoms of hydrogen, the salts may appear to be monobasic, or bibasic, or terbasic, or be, as fashionable language describes them, monometallic, bimetallic, and trimetallic. The individual acids can separately become combined with ammonium NH^4 , and their ammonium salts severally lose HHO , and thereby become reduced to salts of amidogen, NH^2 , with a corresponding reduction of O^1 from the normal amount of the oxygen of each acid. The three acids which, when grouped into a whole, constitute citric acid, never lose their individual powers or properties, and when a citrate is split up by any metamorphosing power, each acid, or acid radical, then set at

liberty, and permitted to act as a single power, has the same saturating capacity that it possessed when existing as part of a citrate, neither more nor less. It is scarcely possible to adduce a stronger argument to prove that citric acid is not *one* acid, but a compound of *three* acids—not an individual, but a company of limited, but strictly ascertained, liabilities.

I shall quote a few examples of citrates, to show what *forms of combination* this constitution and these properties lead to:—

Examples of Citrates.

$\text{H, C}^2\text{H}^3\text{O}^3$	$+ 2(\text{H, C}^2\text{HO}^2)$	Hydrated citric acid.
$\text{K, C}^2\text{H}^3\text{O}^3$	$+ 2(\text{H, C}^2\text{HO}^2)$	Monometallic citrate.
$\text{H, C}^2\text{H}^3\text{O}^3$	$+ 2(\text{K, C}^2\text{HO}^2)$	Bimetallic citrate.
$\text{K, C}^2\text{H}^3\text{O}^3$	$+ 2(\text{K, C}^2\text{HO}^2)$	Trimetallic citrate.
$\text{H, C}^2\text{H}^3\text{O}^3$	$+ 2(\text{NH}^4, \text{C}^2\text{HO}^2)$	Bimetallic ammonium citrate.
$\text{NH}^3, \text{C}^2\text{H}^3\text{O}^2$	$+ 2(\text{NH}^2, \text{C}^2\text{HO})$	Trimetallic amidogen citrate.
$\left\{ \begin{array}{l} \text{NH}^4, \text{C}^2\text{H}^3\text{O}^3 \\ \text{NH}^4, \text{C}^2\text{H O}^2 \\ \text{NH}^4, \text{C}^2\text{H O}^2 \end{array} \right\}$	$+ \left\{ \begin{array}{l} \text{H, C}^2\text{H}^3\text{O}^3 \\ \text{H, C}^2\text{H O}^3 \\ \text{H, C}^2\text{H O}^2 \end{array} \right\}$	Double citrate.
$\left\{ \begin{array}{l} \text{C}^5\text{H}^{11}, \text{C}^2\text{H}^3\text{O}^3 \\ \text{C}^2\text{H}^3, \text{C}^2\text{H O}^2 \\ \text{H, C}^2\text{H O}^2 \end{array} \right\}$	A citrate with three different basic radicals.	

MALIC ACID.

Formula as a bibasic acid, $\text{H}^2, \text{C}^4\text{H}^4\text{O}^5$. *Formula as a double acid*, $\text{H, C}^2\text{H}^3\text{O}^3 + \text{H, C}^2\text{HO}^2$. *Equivalent*, 134.

Malic acid is widely diffused through the vegetable kingdom. It is found in the acid juices of many fruits, such as unripe apples, gooseberries, and currants, in all of which it is accompanied by citric acid. It occurs also in garden rhubarb, in the unripe berries of the mountain ash, and in the state of malate of lime in dried tobacco-leaves.

Preparation.—To the expressed juice of the leaf-stalk of rhubarb or of mountain-ash berries add milk of lime till the acid is nearly, but not quite, neutralised. Then add some chloride of calcium to decompose the malate of potash, which always accompanies the free acid. The citric, tartaric, and phosphoric acids go down with the precipitated lime. Filter the solution; it contains malate of lime. Boil the solution for several hours. Neutral malate of lime gradually separates as an insoluble powder. Wash this powder with cold water, and dissolve it to saturation in a hot mixture of one part nitric acid to ten parts water. Filter the solution, and set it aside to crystallise. It yields well-defined crystals of bimalate of lime ($\text{Ca, C}^2\text{H}^3\text{O}^3 + \text{H, C}^2\text{HO}^2 + \text{Aq}^4$). The solution of these crystals is to be treated with charcoal to separate colouring matter, and is to be evaporated and recrystallised. The salt forms beautiful transparent rhombic prisms. Mix a solution of the

purified crystals with a solution of acetate of lead. The precipitate then produced is malate of lead. Decompose the malate of lead by sulphuric acid, which produces sulphate of lead, and leaves hydrated malic acid in solution. The last traces of lead are removed by the addition of sulphuretted hydrogen.

Properties.—Very soluble and deliquescent, and, therefore, not so easy to crystallise as other organic acids; but when evaporated to a syrup, and left in a warm place, it produces tufts of prismatic crystals. Malic acid has a very sour but agreeable taste. When heated, the crystals fuse below 212° F. When steadily fused at 300° , water is disengaged, and fumaric acid is produced:—

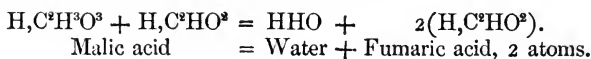

If suddenly heated to 460° , maleic anhydride is formed:—

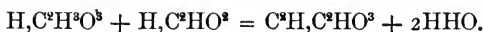

At an intermediate degree of heat, about 350° , the products of decomposing are said to be,

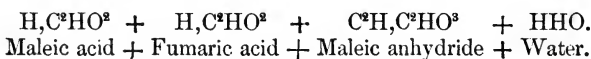

The nature and the relative proportions, not only of the two isomeric acids, but of the hydrated to the anhydrous acids, depend upon the amount and the duration of the heat. I have given elsewhere (“Radical Theory in Chemistry,” page 420) a detailed account of the reactions of the different salts of the malic group.

Malates.—As the malic acid contains two atoms of basic hydrogen, each separately replaceable, it follows that it can form neutral, acid, or double salts, and various amidogen salts. I have adverted to this circumstance at page 426, and in the work above referred to I have examined the matter closely. In fact, it is the evidence that is supplied by the peculiarities of the constitution of the double salts and amidogen salts of the malates, citrates, and similar salts of vegetable acids, which proves that these salts are double and triple salts, and not, as commonly considered, bibasic and tribasic salts. We perceive incontestably that in these salts we have to deal, not only with double and triple basic radicals, but with powers and properties which, being twice and thrice as great as the powers and properties of single acid radicals, demonstrate the existence in these salts of double and triple acid radicals. To attribute these double and triple powers to single acid radicals is, to my mind, destructive of the very notion of chemical equivalence. I can no more comprehend the constitution of a salt which contains *one acid radical* opposed to, and neutralising, *three basic radicals*, than I can comprehend the nature of a galvanic battery in which one positive pole

is opposed to, and neutralises, three negative poles, all of the same individual power. The thing seems to me to be utterly impossible; and I wonder at the singular train of illogical reasoning by which chemists, who profess to believe in the electro-chemical theory, persuade themselves that they can also believe in the existence of such unphilosophical monsters as polybasic acids and polyatomic alcohols.

I quote a few examples of salts belonging to the malic group:—

1. $\text{H}, \text{C}^2\text{H}^3\text{O}^3 + \text{H}, \text{C}^2\text{HO}^2$ Malic acid crystallised.
2. $\text{HN}^4, \text{C}^2\text{H}^3\text{O}^3 + \text{NH}^4, \text{C}^2\text{HO}^2$ Neutral malate of ammonia.
3. $\text{NH}^4, \text{C}^2\text{H}^3\text{O}^3 + \text{H}, \text{C}^2\text{HO}^2$ Acid malate of ammonia.
4. $\text{NH}^4, \text{C}^2\text{H}^3\text{O}^3 + \text{Zn}, \text{C}^2\text{HO}^2$ Malate of ammonia and zinc.
5. $\text{Pb}, \text{C}^2\text{H}^3\text{O}^3 + \text{Pb}^3, \text{C}^2\text{HO}^3$ Basic malate of lead.
6. $\text{C}^5\text{H}^{11}, \text{C}^2\text{H}^3\text{O}^3 + \text{Ca}, \text{C}^2\text{HO}^2$ Malate of amyl and lime.
7. $\text{NH}^2, \text{C}^2\text{H}^3\text{O}^2 + \text{H}, \text{C}^2\text{HO}^2$ The amidogen salt derived from the ammonium salt, No. 3, and bearing to it the same relation that oxamic acid bears to the binoxalate of ammonia. See page 379. The salt No. 7 is commonly called *Aspartic Acid*.
8. $\text{NH}^2, \text{C}^2\text{H}^3\text{O}^2 + \text{NH}^4, \text{C}^2\text{HO}^2$ Aspartate of ammonia.
9. $\text{NHBa}, \text{C}^2\text{H}^3\text{O}^2 + \text{Ba}, \text{C}^2\text{HO}^2$ An aspartate of barytes, in which the amidogen has one of its atoms of hydrogen replaced by a metal, forming a metallic vice-radical (see page 413).
10. $\text{NH}^2, \text{C}^2\text{H}^3\text{O}^2 + \text{NH}^2, \text{C}^2\text{HO}$. A double amidogen salt, produced from No. 2 by the abstraction of $\text{HHO} + \text{HHO}$. This salt is sometimes called *Asparagine*, and sometimes *Malamide*.

GALLIC ACID.

Formula as a tribasic acid = $\text{HHH}, \text{C}^7\text{H}^5\text{O}^6$. *Formula as a triple acid* = $\text{H}, \text{C}^3\text{H}^3\text{O}^2 + \text{H}, \text{C}^2\text{HO}^2 + \text{H}, \text{C}^2\text{HO}^2$. *Equivalent*, 188.

Gallic acid exists ready-formed in many astringent vegetables, particularly in the gall-nut, in sumach, and in valonia. To extract it, soak one part of powdered gall-nuts in three parts of cold water, exposed freely to the air in a warm place. It soon becomes mouldy, and the mouldy skin is to be removed from the solution as often as it is formed. When the liquor is evaporated to half its bulk, pour it from the crystalline deposit. Wash the deposit with cold water; then dissolve it in hot water, filter, and crystallise. The crystals are impure gallic acid. Dissolve again, purify with animal charcoal, and again crystallise from boiling water. Gallic acid can also be obtained by boiling tannic acid with dilute sulphuric acid, in which case the elements of water are assumed, and glucose is produced and separated as well as gallic acid.

Properties.—The crystals are very delicate silky prismatic needles. Soluble in 100 parts of cold water, but in 3 parts of boiling water. Easily soluble in alcohol; sparingly so in ether. Reddens litmus. Taste feebly acid, but very astringent. The constitution of the galls

is not thoroughly understood, I state below what appears to me the probable constitution.

Constitution of the Gallates.

1. $H, C^3H^3O^3 + H, C^2HO^2 + H, C^2HO^2$ Crystallised gallic acid.
2. $H, C^3H^3O^2 + C^2H, C^2HO^3$. The acid dried at $248^\circ F.$, at which heat the two atoms of H, C^2HO^2 lose HHO , and are reduced to the state of anhydride.
3. $NH^4, C^3H^3O^2 + H, C^2HO^2 + H, C^2HO^2$ Crystallised acid gallate of ammonia.
4. $NH^2, C^2H^3O + H, C^2HO^2 + H, C^2HO^2$ The amidogen salt, corresponding to No. 3, produced by saturating the acid No. 2 with dry ammonia gas. Sometimes called Gallamic acid.
5. $Na, C^3H^3O^2 + H, C^2HO^2 + H, C^2HO^2$ Crystallised acid gallate of soda.
6. $Na, C^3H^3O^2 + C^2H, C^2HO^3$ This is the salt No. 5, dried at 210° , at which temperature the anhydride is formed. The gallates in general, like the crystallised acid (see Nos. 1 and 2), are subject to this form of partial decomposition, which has led many chemists to ascribe only three atoms of hydrogen to the gallic radical, and only five atoms of oxygen to the salts. Thus making—
 The dried acid = $H^3, C^7H^3O^5$.
 The soda salt = $NaH^2, C^7H^3O^5$.
7. $Zn, C^3H^2ZnO^3 + Zn, C^2HO^2 + Zn, C^2HO^2$ Gallate of zinc dried at 212° . This is an example of a salt in which part of the hydrogen of the gallic radical is replaced by a metal. The gallates, tartrates, malates, and many other salts, are subject to this exhibition of metallic vice-radicals.
8. $Pb, C^3Pb^3O^2 + C^2H, C^2HO^3$ Basic gallate of lead. In this salt the hydrogen of the radical C^3H^3 is entirely replaced by lead. At the same time the anhydride is formed. This salt was dried at 248° .
9. $\left\{ \begin{array}{l} Pb, C^3H^3O^2 + Pb, C^2HO^2 + Pb, C^2HO^2 \\ Pb, C^3H^3O^2 + C^2H, C^2HO^3 \end{array} \right\}$ In this example we have a trimetallic or neutral gallate, in combination with a salt of the form No. 6.
10. $Fe, C^3H^3O^2 + Fec, C^2HO^2 + Fec, C^2HO^2$ This is the probable composition of writing-ink; but, as usually prepared, ink contains ferrous and ferric tannate, as well as gallate (see page 473).

These examples are sufficient to show the complex nature of the gallates, and how curiously they are modified by the anhydrides and the metallic vice-radicals, which are produced when the normal and basic gallates are decomposed by heat.

Decomposition of Gallic Acid by Heat.—When gallic acid is carefully heated to 410° or 420° F., it produces carbonic acid gas and sublimed pyrogallic acid, with smaller and variable quantities of water and metagallic acid. If suddenly heated to 480° F., it yields no pyrogallic acid, but water distils over, and in the retort is found metagallic acid.

TANNIN. TANNIC ACID.

Formula as a tribasic acid, $H^3, C^9H^5O^6$. *Formula as a triple acid,* $H, C^5H^3O^2 + H, C^2HO^2 + H, C^2HO^2$. *Equivalent, 212.*

Tannin or tannic acid occurs chiefly in oak-bark and in gall-nuts.

Preparation.—The preparation of tannic acid requires an instrument called a percolator, which is represented by fig. 384. Coarsely-powdered gall-nuts are put into the funnel at *d*, the neck of which at *c* has been loosely stopped with a plug of cotton wool. Upon the powder is poured, *e*, a mixture of ten parts of ether with one part of water by weight, enough of it to cover the powder completely; close with a glass stopper, and set aside in a cool place for 24 hours. The stopper is then to be loosened a little, and the liquor is to be allowed to drop slowly into the flask. The operation is repeated with fresh ether. The liquids obtained in the flask are to be shaken together, and then allowed to rest, when they separate into two strata, the lowermost one of which, *a*, is a syrupy solution of tannic acid in water, and the uppermost green liquor, *b*, is ether, containing gallic acid and colouring matter. The solution of tannic acid is removed by a pipette, and after being gently evaporated to dryness in a capsule is washed with ether. The dry mass is redissolved in water, and evaporated in vacuo. It forms a pale-yellow powder, not crystalline. It has a powerful astringent taste. It is very soluble in water, slightly in weak alcohol, and scarcely at all in ether. It reddens litmus.

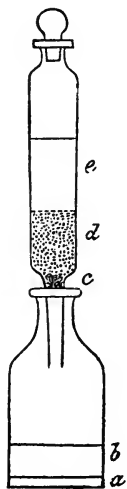

384.

Composition of Tannic Acid and the Tannates.—It is impossible to learn, from an examination of the published analyses of tannic acid, what is its exact composition. There is probably more than one kind of tannic acid: it occurs in company with gallic acid, which nearly resembles it; both these acids change their composition while being dried to expel hygroscopic water; none of the tannates can be obtained in crystals; and there are even other circumstances which render it difficult to ascertain the precise constitution of these salts. Upon the whole, I consider it likely that tannic acid resembles gallic acid in all respects, excepting the constitution of one of its constituent radicals. I will cite them side by side to show this difference:—

Gallic Acid.	Tannic Acid.
H, C ³ H ³ O ²	H, C ⁵ H ³ O ²
H, C ² H O ²	H, C ² H O ²
H, C ² H O ²	H, C ² H O ² .

It will be found that this formula agrees pretty well with the reactions of the acid and its salts, and also with the percentage analyses.

Strecker, who has analysed tannic acid, states its composition to be in the unitary formula C²⁷H²²O¹⁷; but this was for acid which had been dried at 248°, during which operation an atom of water, HHO, is expelled. Adding this water to the formula we have C²⁷H²⁴O¹⁸, and dividing the formula by 3 we have C⁹H⁸O⁶, which, on the radical theory, is equal to H, C⁵H³O² + H, C²HO² + H, C²HO². The partially decomposed acid, which was analysed by Strecker, may be explained in a formula as follows:—

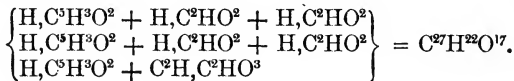

This is a salt which contains two atoms of normal tannic acid and one atom of tannic acid, including the anhydride C²H, C²HO³, which so often occurs in the drying of other acids, gallic acid, malic acid, &c.

There is a salt of lead which, after being heated, contains C²⁷H¹⁹Pb³O¹⁷, which agrees with the partly decomposed acid, after replacing H, in the three atoms of H, C⁵H³O², by Pb. If we add to this unitary formula one atom of water, it becomes C²⁷H²¹Pb³O¹⁸, which, divided by 3, gives C⁹H⁷PbO⁶, equal to Pb, C⁵H³O² + H, C²HO² + H, C²HO².

There is another salt of lead, which is described as containing C²⁷H¹⁹Pb³O²⁰, when dried at 212°. This, divided by 3, is equal to

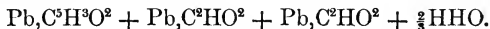

If dried a little higher, or perhaps a little longer, this $\frac{2}{3}$ aq might have been driven off, and the neutral trimetallic salt would have been produced.

Conversion of Tannic Acid into Gallic Acid.—Strong acids and strong alkalies, boiled with an aqueous solution of tannic acid, convert it into gallic acid and glucose. The decomposition is commonly put into an equation thus:—

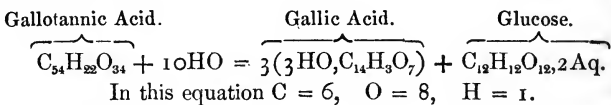

On the Radical Theory, using the formulæ above explained, and H = 1, O = 16, C = 12, the metamorphosis may be represented thus:—

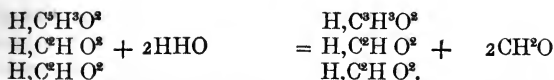

Tannic acid + Water, 2 atoms = Gallic acid + Sugar, 2 atoms.

When tannic acid is heated to about 620° it is decomposed, and, like gallic acid, it yields pyrogallic acid and metagallic acid, accompanied by water and carbonic acid. The unitary formula of pyrogallic acid is $\text{C}^2\text{H}^2\text{O}$, that of metagallic acid is $\text{C}^6\text{H}^4\text{O}^2$. These may be put into the form of radicals as follows:—

Decomposition of Tannic Acid by Heat.

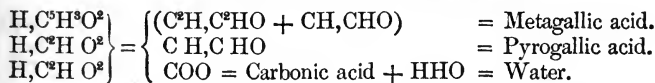

According to this idea, pyrogallic acid is the suboxide of formyl, and this is combined in metagallic acid with the suboxide of the radical C^2H . These two compounds seem to be called acids without much propriety, for they are not substances which contain replaceable basic hydrogen. The following examples of pyrogallates prove this clearly:—

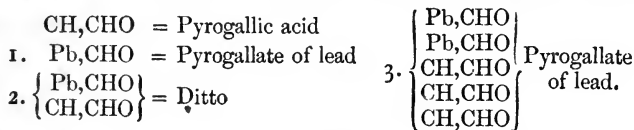

Gmelin's formula for No. 1 is $6\text{PbO,C}^{12}\text{H}^6\text{O}^6$, and for No. 3 it is $3\text{PbO},2\text{C}^{12}\text{H}^6\text{O}^6$.

The evidence respecting the metagallates is less evident. It is said that there is a silver salt composed as follows:— $\text{C}^6\text{H}^3\text{AgO}^2$. But of this and other metagallates very little is known.

Uses of Tannic Acid. 1). *Ink-making.*—The basis of common writing ink is a ferric tannate, which, as usually prepared, is mixed with ferric and ferrous gallate, the salts being suspended in water by mucilage. The following preparation yields very good ink:—Digest 12 ounces of bruised gall-nuts in a gallon of water, then add 6 ounces of green copperas, 6 ounces of gum arabic, and 4 or 5 drops of kreasote to prevent the ink from becoming mouldy. Allow the mixture to digest at ordinary temperatures for two or three weeks, under frequent stirring. At the end of that time the clear liquor may be decanted for use. Ink-stains on linen turn yellow when washed with soap, forming what is termed an iron-mould. The yellow stain is due to ferric oxide in combination with the linen. If, when the ink-stain is fresh, it is washed with a solution of oxalic acid, it can be removed. The oxalic acid must afterwards be washed away with water, or the cloth will rot.

2). *Leather-making*.—The most important compound formed by tannic acid is that which it forms with gelatin. When a solution of isinglass, or of any kind of gelatin, is added to an aqueous solution of tannic acid, a copious gelatinous precipitate is produced. This compound, when in a solid form, constitutes leather. A piece of prepared skin, put into a solution of tannic acid, absorbs the acid, and is converted into leather. In this case a most insoluble compound is formed by two substances, both of which are extremely soluble in water.

PYROGALLIC ACID.

Formula, CH_3CHO = Formyl formylate; *Equivalent*, 42.

This substance is produced by the decomposition of the tannic and gallic acids. It may be prepared by sublimation from these acids, or from the extract obtained by boiling down a solution of gall-nuts. The extract may be put into a shallow iron pan, covered with a piece of filtering paper, and over that a cone of writing paper. The application of a gentle heat sends the pyrogallic-acid vapour through the filtering paper up into the paper cone, where it condenses into light crystals.

Theory.—The constitution of this compound, and its relation to the tannic and gallic acids, have been sufficiently explained.

Properties of Pyrogallic Acid.—It forms bulky brilliant plates, which are soluble in water, alcohol, and ether. The solution is bitter. If pure, it does not redden litmus. It is not an acid. It fuses at 240° , and soon after rises in vapour. If dry, it does not readily decompose. If in solution, and especially if in a solution of potash, it absorbs oxygen with such avidity, that it is useful as a means of removing oxygen from gaseous mixtures. The solution becomes brown, and then contains carbonate and acetate of potash. Pyrogallic acid produces a deep-blue solution with pure ferrous salts, and a bright-red solution with ferric salts. When dropped into milk of lime it produces a beautiful purple colour. Added to salts of silver, gold, and platinum, it reduces the metals. It is much employed in photography to develop the latent image produced by light on argentiferous collodion.

BENZOIC ACID.

Formula, $\text{H}_2\text{C}_7\text{H}_5\text{O}_2$ = Hydra benzylete; *Equivalent*, 122; *Atomic measure in the gaseous state*, 2 volumes; *Specific gravity of gas*, 61.

Preparation.—When gum-benzoin is gently heated, benzoic acid rises from it in vapour, and condenses on any cold object in brilliant crystalline leaves and needles. The sublimation may be performed in the manner described above, under the article Pyrogallic Acid. It makes an elegant experiment when performed as represented at page 57. The following process has been recommended by Dr. Mohr, and is

universally employed for the preparation of this acid in quantity. Fig. 385 represents the necessary apparatus; *a* is a plate of iron, which is placed over a charcoal furnace, or over a gaslight, where the heat can be carefully regulated; *b* is a flat-bottomed cast-iron pan, about 2 inches deep and 8 inches in diameter; *c* is a flat tin-plate funnel, fitted to the pan, and adjusted by cement of linseed meal; *d* is the neck of this funnel, which is a cylindrical tube of about 3 inches diameter and the same height, and over the mouth of which a piece of tulle is tied; *e* is a box of pasteboard, or of wood lined with paper, adjusted to the neck of the funnel. The box should have a moveable cover.

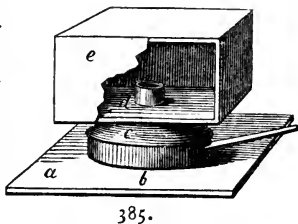

385.

The gum-benzoin should be spread evenly in the flat pan to the thickness of three-quarters of an inch; and when the apparatus is put together as above described, a very gentle and regulated heat should be applied below the iron plate, and sustained from three to five hours. The box, *e*, must never become warm to the hands, nor must any vapour of benzoic acid be seen to escape from it. If these signs appear, the heat must be reduced. Finally, the heat is entirely withdrawn, and the apparatus is allowed to cool. Upon opening the box, the benzoic acid will be found in brilliant white crystalline leaves and needles, grouped into beautiful masses. The residue of gum-benzoin may be pounded coarsely in a mortar, and the sublimation be repeated with a profitable result.

Properties of Benzoic Acid.—White, glistening, light, flexible plates and needles. Melts at 248° ; sublimes at 293° ; boils at 462° . The vapour is acrid and irritating. In the open air it burns with a smoky flame. Soluble in 200 parts of cold water, in 25 of boiling water, also in alcohol and in ether. Without odour when pure, but it generally smells of benzoin or vanilla, from a slight incorporation of a fragrant oil. It readily forms salts, most of which are crystallisable, and soluble in water and in alcohol. The radical of the acid, Benzyl = C^7H^8 , readily passes into a great variety of other compounds, as I shall show by quoting a few formulæ:—

1. $H, C^7H^5O^2$ Hydrated benzoic acid.
2. H, C^7H^5O Essential oil of bitter almonds. The crude oil contains other compounds, namely, hydrocyanic acid, benzoic acid, and benzoin. That mixture is poisonous; but the pure Aldide H, C^7H^5O is not poisonous.
3. $C^7H^5, C^7H^5O^2$ Benzoic anhydride.
4. $C^8H^8, C^7H^5O^2$ Benzoacetic anhydride. See page 297.

5. $K, C^7H^5O^2$ Neutral benzoate of potash.
6. $K, C^7H^5O^2 + H, C^7H^5O^2$ Acid benzoate of potash.
7. $ZH^4, C^7H^5O^2$ Benzoate of ammonia.
8. ZH^2, C^7H^5O Benzamide.
9. $Fec, C^7H^5O^2$ Ferric benzoate.
10. $C^2H^5, C^7H^5O^2$ Benzoic ether. Benzoate of ethyl.
11. C^7H^5, ClO Chloride (oxychloride) of benzoyl.
12. C^7H^5, CNO Cyanide (cyanate) of benzoyl.
13. C^7H^5, SO Sulphide (oxysulphide) of benzoyl.

SECOND SERIES OF EXAMPLES OF ORGANIC SALTS.

SALTS PRODUCED BY BASIC RADICALS.

ISOLATION OF COMPOUND ORGANIC RADICALS.—The compound acid radicals have not yet been isolated, and are only known to us in combination with other radicals; but several of the basic radicals have been isolated, to wit, methyl, ethyl, amyl, and others; and I shall describe the process by which it is possible to isolate ethyl, to serve as a general illustration.

Iodide of ethyl and granulated zinc are sealed hermetically in a strong glass tube, exhausted of air, and the sealed tube is exposed for two hours to a heat of 300° in an oil-bath: decomposition is effected, and several products are formed, solid and liquid. The solid substances consist of a compound of iodide of zinc with zinc ethyl. The liquid consists of ethyl, accompanied by hydride of ethyl and vinyl, both liquefied by the pressure. When the point of the sealed tube is broken off, under water, these liquids become gases and escape. Of the different kinds of gas present in the tube the ethyl is the least volatile, so that it passes off last, and can be collected separately in a state of tolerable purity. This operation is described fully by Dr. Frankland in the *Quarterly Journal of the Chemical Society*, vol. ii. 281,

Properties.—A colourless gas, with a slight ethereal smell. It burns with a bright flame. Insoluble in water. Soluble in alcohol. By a pressure of $2\frac{1}{2}$ atmospheres, at 38° , it is liquefied. Chlorine has no action upon ethyl in the dark, but it combines with it in diffused light, and forms a colourless liquid. Ethyl is not absorbed by anhydrous sulphuric acid, nor by oil of vitriol.

The circumstance that ethyl and the other isolated basic radicals do not readily combine with chlorine, iodine, and bromine, to produce the corresponding chlorides, iodides, and bromides, was at first held to prove that they were not true radicals; but that argument is not sound, because the inorganic radicals, when isolated, often lose many of the

active powers which they possess when in combination—witness the element nitrogen.

The isolated radicals have each an atomic measure of one volume, so that their specific gravity in the state of gas is the same as their atomic weight. In the case of ethyl, this is 29. Their atomic measure when in the state of salts is one volume, except in the case of vinyl, which, in consequence of having an even number of atoms of hydrogen, loses its atomic measure when present in gaseous salts.

SALTS OF ETHYL = C²H⁵.

The principal salts of Ethyl are enumerated in the Table at pages 145, 146. A glance at that Table discerns their composition, atomic weights, specific gravities, and atomic measures, and shows the great range of power which enables Ethyl to enter into combination with all other radicals, organic and inorganic, oxidised and non-oxidised. Similar information is supplied by the same Table in respect to the radicals Methyl and Amyl. If the list of salts formed by these organic radicals is compared with the list of salts formed by inorganic radicals, for example, by potassium, sodium, and lead, as shown by the Table given at page 19 in this work, the conclusion that must be drawn is, that as regards equivalence in chemical power and universality in action, the organic radicals lose little by comparison with the inorganic radicals, and that the chemists who admit the existence of inorganic radicals, but deny the existence of organic radicals, admit facts, and deny facts, uninfluenced by logical or mathematical convictions.

ALCOHOL.

Formula, H,C²H⁵O; *Equivalent*, 46; *Specific gravity of gas*, 23; *Atomic measure*, 2 volumes; *Specific gravity of liquid at 60° F.*, 0.7938.

Sometimes called Ethylic, or Vinic Alcohol. Its solutions in water at different strengths are called proof-spirit and spirit of wine. It is the hydrated oxide of ethyl, and is the principal alcohol of the series indicated in Group 5), page 415.

Production of Alcohol by the Fermentation of Sugar.—I have explained this process at page 343. When a solution of sugar (*Vinylate* = CH²O) in water is mixed with yeast and exposed for some time to a moderate heat, the sugar is decomposed, and converted into alcohol and carbonic acid. Thus:—

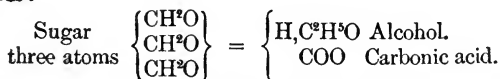

The carbonic acid goes off as gas, and the alcohol remains in the

liquor (the wash), from which it can be separated by distillation, alcohol being more volatile than water.

Production of Alcohol from Olefiant Gas (Vinyl).—A large glass globe, of thirty-one litres' capacity, was exhausted of air and filled with olefiant gas (vinyl = CH^2). 900 grammes of pure and boiled sulphuric acid was poured into the globe in several portions, and then a few kilogrammes of mercury. The whole was submitted to violent and continued agitation, and after having been shaken 53,000 times, much of the gas was absorbed. The sulphuric acid was mixed with five or six times its bulk of distilled water, and after repeated distillations, and separation of the acid by carbonate of potash, there was finally obtained a product of diluted alcohol, which corresponded to 45 grammes of absolute alcohol. This contained three-fourths of the olefiant gas that was absorbed. The rest was lost in the manipulations. The operation was repeated with olefiant gas prepared by a circuitous process from coal-gas.

These processes prove that it is possible, by chemical means, to build up the radical C^2H^5 from the radical CH^2 . The last process, which is due to M. Berthelot, is an important scientific demonstration. The process by fermentation is that by which alcohol is prepared for use in the arts.

Separation of liquids, of different degrees of volatility, by the process of Fractional Distillation.—I have said that alcohol can be separated from water by distillation, because it is more volatile than water. Upon this point I may make the general remark, that, in the chemical manipulation of volatile substances, advantage is very frequently taken of the fact, that different compounds rise into vapour at different degrees of heat; and it sometimes happens that several compounds mixed together in one liquid can only be separated from one another by a distillation conducted with due regard to this particular. The apparatus used in such a process is represented by fig. 386.

It consists of a small retort with a bent neck, and having a tubulure sufficiently wide, and placed in a proper position, to permit a thermometer to be adjusted to it by a cork, so as to dip into the boiling liquor and show from time to time the temperature at which the distillation proceeds. The heat placed below the retort is regulated according to the indications of the thermometer. Thus, a certain

liquid present in the mixture may be distilled off at 100°F .; the heat may then be raised to 120° or 150°F ., and another liquid distilled off; then raised to 212° , the boiling point of water; and finally, if

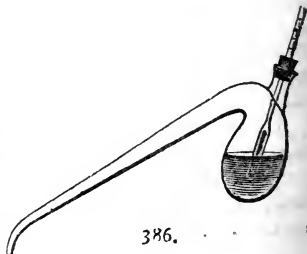

necessary, to 250° , 300° , &c. Of course, previously to each rise of temperature, the receiver which collects the distilled liquor is changed, in order that each product may be collected apart. This process is called *fractional distillation*.

Rectification of Alcohol.—When spirit of wine is distilled, the alcohol goes over first, but accompanied by some water. By repeated distillations, or rectifications, the proportion of water is diminished, until the product contains 90 per cent. of alcohol. After that degree of concentration is reached, other means must be used to abstract the rest of the water.

Absolute Alcohol.—To prepare absolute alcohol, first distil rectified alcohol from charcoal, which serves to separate the essential oils that give flavour and odour to different spirits. These oils combine with the charcoal. Then mix the spirit with half its weight of unslaked quicklime, and let it digest cold for several days. The lime takes the water from the spirit to become slaked. Then gently distil the mixture, by the heat of a bath of chloride of calcium. The hydrate of lime retains the water, and absolute alcohol distils over. The distilling apparatus represented by fig. 243, page 241, is very suitable for the distillation of alcohol.

Properties of Alcohol.—Alcohol is a volatile inflammable liquid, without colour, having an agreeable spirituous odour, and an acrid, burning taste. It boils and forms vapour at 173° F., which condenses unchanged. It cannot be solidified by any degree of cold. It mixes in all proportions with water, and the mixtures are called spirit of wine. There is a particular mixture according to which the Excise duty is paid in England, and which is called *proof-spirit*. This is defined by Act of Parliament to be “such spirit as shall at the temperature of 51° F. weigh exactly twelve-thirteenth parts of an equal measure of distilled water.” This is said to contain by weight $50\cdot76$ of alcohol, and $49\cdot24$ of water, and it has at 60° F. a specific gravity of $0\cdot92$. The strength of various mixtures of alcohol and water by volume is given in the Table at page 480.

Most of the alcohol prepared for sale is drunk as a stimulant. It is the principle which gives exhilarating properties to all fermented liquors, to ale, porter, wines, brandy, rum, gin, &c. When drunk in large quantities, or in a concentrated state, it acts as a powerful narcotic poison, first producing intoxication, and sometimes occasioning fatal results.

It is of great use to the chemist, partly as furnishing a cleanly and convenient fuel to supply heat for his experiments, and partly as a solvent and reagent. It burns in spirit-lamps with little light but with much heat, and without smoke if properly supplied with air. One equivalent, or two volumes of vapour of alcohol contain H, C^2H^2O . This is converted entirely into carbonic acid and water. The quantity of oxygen required is shown by the following equation:—

[See page 481.]

TABLE OF MIXTURES OF ALCOHOL AND WATER,
According to TRALLES. Water at 40° F. = 10000.

Per Cent. of Alcohol by Volume.	Specific Gravity at 60° Fahr.	Per Cent. of Alcohol by Volume.	Specific Gravity at 60° Fahr.	Per Cent. of Alcohol by Volume.	Specific Gravity at 60° Fahr.
0	9991	34	9596	68	8941
1	9976	35	9583	69	8917
2	9961	36	9570	70	8892
3	9947	37	9556	71	8867
4	9933	38	9541	72	8842
5	9919	39	9526	73	8817
6	9905	40	9510	74	8791
7	9893	41	9494	75	8765
8	9881	42	9478	76	8739
9	9869	43	9461	77	8712
10	9857	44	9444	78	8685
11	9845	45	9427	79	8658
12	9834	46	9409	80	8631
13	9823	47	9391	81	8603
14	9812	48	9373	82	8575
15	9802	49	9354	83	8547
16	9791	50	9335	84	8518
17	9781	51	9315	85	8488
18	9771	52	9295	86	8458
19	9761	53	9275	87	8428
20	9751	54	9254	88	8397
21	9741	55	9234	89	8365
22	9731	56	9213	90	8332
23	9720	57	9192	91	8299
24	9710	58	9170	92	8265
25	9700	59	9148	93	8230
26	9689	60	9126	94	8194
27	9679	61	9104	95	8157
28	9668	62	9082	96	8118
29	9657	63	9059	97	8077
30	9646	64	9036	98	8034
31	9634	65	9013	99	7988
32	9622	66	8989	100	7939
33	9609	67	8965		

The instrument called Tralles's Alcoholometer has on it 100°, which agree with the percentages of alcohol marked in the above Table.

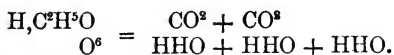

Six volumes of oxygen exist in thirty volumes of atmospheric air, which quantity is therefore demanded for the complete combination of two volumes of alcohol vapour.

Alcohol as a Solvent.—The preceding details show that alcohol is of great use in the preparation and purification of organic compounds, many of which it dissolves without altering their properties, and gives up in the solid state, either crystallised or amorphous, when it is separated from them by evaporation. It dissolves many gases, some more freely than water dissolves them, such as nitrous oxide, carbonic acid, phosphuretted hydrogen, and cyanogen. Iodine and bromine dissolve in it, but gradually decompose it. Caustic potash, soda, and ammonia dissolve in it, but their carbonates do not. Most deliquescent salts dissolve in it. The efflorescent salts do not. With many salts, such as chlorides and nitrates, it forms crystals. It readily dissolves essential oils, the vegetable alkaloids, some of the vegetable acids, and the resins, with which it produces *varnishes*. Sugar and soaps are dissolved more sparingly, and fixed oils and fats only slightly.

Fermented Liquors.—The expressed juice of any fruit which contains sugar, or the aqueous extract of any substance which contains sugar, on being subjected to fermentation, produces a peculiar alcoholic liquor, which bears a name that is in some degree expressive of its origin. Thus the liquor derived from the fermented juice of the grape is called wine, and from the fermented juice of other fruits we have currant-wine, gooseberry-wine, elder-wine, &c. From a decoction of ginger we have ginger-wine. From the juice of apples we have cider, from the juice of pears we have perry, and from an extract of malt, or from sugar alone, we have beer. These liquors are fermented, but are not distilled. They contain, therefore, not only alcohol, but all the soluble substances that were contained in the original vegetable juice, and which were not destroyed by the process of fermentation. To these other substances they owe the odour and flavour by which they are severally distinguished from mere mixtures of alcohol and water. Sugar is the substance which provides the alcohol. If the fermentation is complete, the sugar will be entirely removed, and the liquor will not be sweet. Thus claret, burgundy, and the wines of the Rhine and the Moselle contain no sugar; whereas tokay contains 17 per cent. of sugar, port-wine from 3 to 7 per cent., sherry from 1 to 5 per cent., and most home-made wines a great excess of unfermented sugar. The flavour and odour of wines depend partly upon certain essential oils which are derived from the plants made use of for their production, partly upon ethers, or essences, which are produced from the decomposition of the sugar or of those essential oils, and partly upon the aromatic, acidulous, mucilaginous, and astringent substances of a non-volatile nature, which

are supplied by the juices of the different vegetable substances employed to produce the wines. I have given, at page 387, and in a subsequent section, some account of the nature and chemical composition of the volatile ethers and essences. Many of them can be imitated artificially, and there is no doubt that this is a part of chemical knowledge that will hereafter receive great extension and practical application.

Distilled Alcoholic Liquors.—When liquors which contain alcohol are distilled, the alcohol rises in company with more or less water, and with a certain quantity of the essential oils or ethers that may be present in the liquors that are subjected to distillation, while sugar, colouring matters, mucilage, fixed acids and salts, and all other non-volatile substances remain behind in the still. On this principle, all drinkable alcoholic liquors are prepared, and their differences in flavour and odour depend mainly upon peculiarities in the essential oils that are derived from the vegetables, whose fermented juices or extracts are distilled for the sake of the spirit they yield. Thus, *rum* is distilled from molasses, and the flavour is derived from an oil peculiar to the sugar-cane. *Brandy* is distilled from wine, and sometimes from expressed grapes, and owes its flavour to a product of the vine. The dark colour of some brandies is given to them artificially by the addition of burnt sugar. *Whiskey* is distilled from a mash made with malt or other grain. *Arrack* is distilled from fermented rice. But the flavouring principles of rum and of brandy can be prepared chemically; that of rum consisting of the butyrate of ethyl, and that of brandy of the butyrate of amyl. See pages 387, 388.

We have thus two distinct classes of spirituous drinks. The FERMENTED liquors, such as wines and beers, which contain all the soluble constituents of the vegetable juices or extracts from which they are prepared, except so far as those constituents are decomposed by fermentation. And, secondly, the DISTILLED spirits, which contain only volatile substances, chiefly alcohol, water, and essential oils. There is, however, a third class, which it is necessary to notice, and which is that of *liqueurs* or *compounds*. These consist of distilled spirits flavoured by the subsequent addition of aromatic or ethereal substances, which give the flavours that are desired. Thus gin is flavoured with oil of juniper-berries, and sometimes with oil of peppermint, of cloves, or of bitter-almonds. Eau de Cologne, and many articles of perfumery, are prepared in this way, and in some cases, spirits intended for beverages, besides being prepared with essential oils, are mixed with sugar and other soluble non-volatile compounds. When these fixed substances are not present, the mixtures are usually purified by re-distillation (rectification). In the small way, the apparatus represented by fig. 243 may be used for such a purpose.

Percentage of Absolute Alcohol contained by some Beverages :—

Port	15 to 17	Claret	8 to 9
Sherry	14 to 16	Rudesheimer	7 to 8
Madeira	14 to 17	Edinburgh ale.	5 to 6
Malmsey	13	London porter	5½

ETHER.

Formula, C^2H^5, C^2H^5O ; *Equivalent*, 74; *Specific gravity of gas*, 37; *Atomic measure*, 2 volumes; *Specific gravity of the liquid at 55°*, 0.724.

Preparation of Ether.—The preparation of ether is dangerous, and should not be undertaken by inexperienced operators. Not only is the liquid very combustible, but its vapour is extremely volatile, and when mixed with atmospheric air it is as violently explosive as a mixture of atmospheric air and coal-gas. It ought never to be poured from a bottle near a flame. It is dangerous to spill it on the floor and allow the vapour to mix with the air of the room. I must describe the process of preparing ether, because of its theoretical importance; but the student of chemistry should only venture to prepare it, and to make experiments with it, in small quantities, and with due care.

1. The apparatus to be used is represented by fig. 243. All the joints must be carefully fitted, the condensing-water must be very cold, and continuously supplied, and the condensing-flask, *g*, must be put up to its neck in cold water, the point of the adapter, *f*, being passed through a cork, provided also with a safety-tube. Mix four ounce measures of strong alcohol with two ounce measures of oil of vitriol, put the mixture into the retort, adjust the apparatus as shown in the figure, and distil with a gentle heat until the mixture begins to blacken. Then release the retort, put into it one ounce measure of strong alcohol, and continue the distillation until ether ceases to come over.

2. *The Continuous Process.*—The process above described is not used for the preparation of ether in large quantities. What is called the continuous process is now followed. In this case, the mixture that is first submitted to distillation consists of equal measures of oil of vitriol and of alcohol, sp. gr. 0.83. This is contained in a large retort connected with an efficient condensing apparatus. There is connected with the retort a tube passing to a reservoir of alcohol, from which a current passes, so as to keep a constant level in the retort. A heat is at once applied sufficient to make the mixture boil steadily. A mixture of ether and water, accompanied by a little alcohol, then passes over regularly, until about thirty times as much alcohol as that originally mixed with the acid has been converted into ether. The sulphuric acid is by that time become too dilute to continue the process.

Rectification of Ether.—The ether produced by these operations is impure, and requires to be rectified. To this end, it must be mixed

with an equal bulk of water, containing one-sixteenth of its weight of carbonate of potash, and after being shaken with this mixture, must be set aside to rest, when it settles into two liquids. The alkaline solution combines with the alcohol, the water, and any sulphuric acid that may be present, and sinks to the bottom. The uppermost liquor consists of ether holding a little water in solution. This water can be separated by letting the ether stand for a day or two upon quicklime or chloride of calcium, after which the ether is to be distilled by the heat of a water bath, and the distilled ether is to be received in a vessel cooled by ice-cold water.

Properties of Ether.—Ether is an extremely limpid liquid, which is colourless, transparent, volatile, and combustible, having a peculiar and powerful odour, and a taste which at first is hot and afterwards cooling. A few drops mixed with cold water may be drunk. It is stimulating and intoxicating. If the vapour is inhaled, it produces exhilaration, immediately followed by insensibility to pain. On this account it was for some time used to diminish the sufferings of patients when under surgical operations; but as its employment was attended with danger, and sometimes produced fatal results, it has been superseded by the use of chloroform, which more speedily and certainly produces insensibility to pain, with less excitement to the system and less danger.

Ether boils at 95° F., and freezes at -24° F. It is freely dissolved by alcohol, but only slightly by water. When pure ether is mixed with an equal volume of water, each takes up about one-eighth volume of the other, so that the measures remain apparently the same. Upon this property is founded a process for testing the quantity of alcohol contained in impure ether. Fig. 387 represents a glass tube, six inches long and half an inch wide, graduated into equal spaces. Fill ten spaces with cold distilled water, then carefully ten spaces with ether. Close the mouth of the tube with the finger, shake the mixture, and then let it settle. The water and ether then separate; and the increase in the quantity of the lower liquor, or water, shows the amount of alcohol abstracted by the water from the ether.

Uses of Ether.—As a medicine. To produce cold, by its rapid evaporation. As a solvent for fatty bodies. This property renders it important in the separation of organic bodies from one another. It dissolves iodine, sulphur, phosphorus, ammonia, deutoxide of nitrogen, and several metallic salts, such as PtCl , FeCl , SnCl , AuCl , HgCl . It is remarkable that these are all chlorides of basylic radicals. The last two compounds are separated, by agitation with ether, from the water of their aqueous solutions, and rise with the ether to the surface.

Combustion of Ether.—When ether is burnt, it produces, like alcohol, carbonic acid and water; but as it contains more carbon in proportion



387.

to the hydrogen than is contained in alcohol, the flame is brighter, and if the combustion is interfered with, by the action of a cold body on the flame, it readily deposits carbon. An equivalent of ether requires twelve equivalents of oxygen for its perfect combustion:—

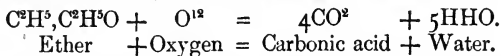

Consequently, an atomic measure, or two volumes, of vapour of ether, requires sixty volumes of atmospheric air to effect its combustion.

Theory of the Production of Ether from Alcohol.—A multitude of explanations have been given of the process of etherification, and it is, therefore, not easy to cite one that is free from objections. The radical theory, however, shows us very simply how the metamorphoses may occur, although, like all other theories, it is without absolute evidence to demonstrate that so they do occur. The constitution of alcohol is $\text{H}, \text{C}^2\text{H}^5\text{O}$, that of sulphuric acid is H, SO^2 , that of water is H, HO , that of ether is $\text{C}^2\text{H}^5, \text{C}^2\text{H}^5\text{O}$, that of sulphate of ethyl is $\text{C}^2\text{H}^5, \text{SO}^2$, and that of bisulphate of ethyl is $\text{C}^2\text{H}^5, \text{SO}^2 + \text{H}, \text{SO}^2$. These are the compounds concerned in etherification, and these are the formulæ applied to them by the radical theory.

When alcohol is acted on by oil of vitriol, the change effected is as follows:—

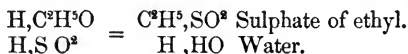

If the alcohol is in a certain excess, this process goes on until there is formed in the liquor a considerable quantity of sulphate of ethyl and water. The sulphuric acid then ceases to act. The heat being continued, a point is reached at which the decomposition of the sulphate of ethyl is effected thus:—

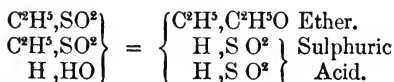

The ether ($\text{C}^2\text{H}^5, \text{C}^2\text{H}^5\text{O}$) being extremely volatile, immediately distils over, the sulphuric acid, freed from ethyl, takes up hydrogen and forms H, SO^2 , and if alcohol flows into the retort (according to the continuous process, No 2 above) the formation first of sulphate of ethyl, and then of ether, is repeated continuously. But, since every two atoms of alcohol, on being converted into one atom of ether, liberate one atom of water:—

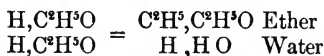

it follows, that the water which is thus produced, and which for the most part rests with the sulphuric acid, gradually weakens it too much to enable it to decompose the alcohol. The process then stops.

If otherwise, the sulphuric acid, and not the alcohol, is in a certain excess, the free sulphuric acid combines with the sulphate of ethyl first formed, and produces the double salt sometimes called bisulphate of ethyl, and sometimes sulphovinic acid:—

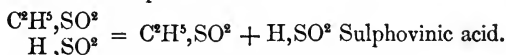

This sulphovinic acid does not give off ether when heated. If it is diluted with water and heated it gives off alcohol, and leaves sulphuric acid in the retort:—

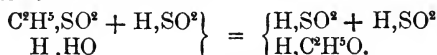

But if it is mixed with alcohol and heated, it then gives off ether:—

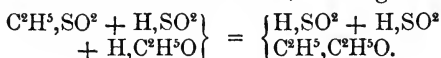

If, therefore, sulphuric acid of sufficient concentration is kept up at a certain temperature, and alcohol flows in continuously, the decomposition of alcohol, the formation of ether, and the separation of water, all go on regularly, until the accumulation of water in the retort deadens the power of the acid by too great dilution.

Sulphate of Ethyl.

Formula, $\text{C}^2\text{H}^5, \text{SO}^2$; *Equivalent*, 77; *Systematic name*, Ethyla sulphete.

Preparation.—Pass anhydrous sulphuric acid into anhydrous ether, kept cold by ice. A syrup-like liquor is formed, which is to be shaken with its own bulk of ether and four times its bulk of water. When the mixture is left at rest, sulphate of ethyl rises to the surface. It is to be purified with milk of lime, washed with water, filtered, and dried in vacuo. It forms an oily liquid, possessed of a burning taste and of an ethereal odour like peppermint. It is readily decomposed by heat.

Theory of its formation:—

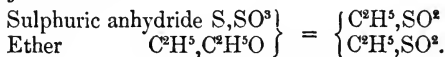

SULPHOVINIC ACID. *Sulphethylic Acid.*

Formula, $\text{C}^2\text{H}^5, \text{SO}^2 + \text{HSO}^2$; *Equivalent*, 126; *Systematic name*, Ethyla sulphete cum hydra sulphete.

I have explained the origin of this double salt in the article on etherification, page 485. It may also be formed by gradually adding anhydrous ether, perfectly free from alcohol, to concentrated hydrated sulphuric acid. The temperature rises rapidly, but must be prevented, by cooling applications, from rising above 250°. When the operation

is complete, and the mixture is diluted with water, nearly all the ether will be found converted into sulphovinic acid :

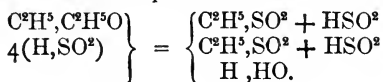

The sulphovinic acid exchanges its replaceable hydrogen for other basic radicals, and produces a series of salts which are called sulphovinates. Thus with barium it produces the double sulphate $\text{C}^2\text{H}^5, \text{SO}^2 + \text{BaSO}^2$. This salt, and all the sulphovinates, and nearly all the double sulphates produced with other organic radicals instead of ethyl, are soluble in water, even when they contain barytes, and this circumstance has led to much dispute respecting the true constitution of such salts, to which disputes I have already referred at 20), page 417.

Chloride of Ethyl. Hydrochloric Ether.

Formula, C}^2\text{H}^5, \text{Cl} ; Equivalent, 64.5 ; Specific gravity of gas, 32.25 ; Atomic measure, 2 volumes ; Specific gravity of liquid at 32}^\circ \text{F., 0.921 ; Systematic name, Ethyla chlora.

Prepared by distilling a mixture of 3 parts of oil of vitriol, 4 parts of fused chloride of sodium, and 2 parts of alcohol. I need not repeat that this and all operations with ethers of every kind require great care to prevent accidents from explosions or fire. It forms a colourless liquid, very volatile and combustible, sparingly soluble in water, freely in alcohol. It is subject to a great variety of decompositions, of which I will notice three.

1). If passed through red-hot tubes it produces hydrochloric acid and vinyl gas:—

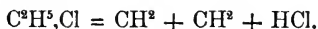

2). When heated to 212}^\circ in a sealed tube with an alcoholic solution of potash, it produces chloride of potassium and common ether:—

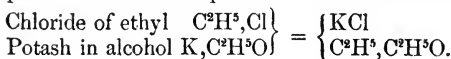

3). If the vapour of this ether is passed over heated hydrate of potash, water, vinyl gas, and chloride of potassium are formed:—

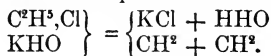

Acetate of Ethyl. Acetic Ether.

Formula, C}^2\text{H}^5, \text{C}^2\text{H}^3\text{O}^2 ; Equivalent, 88 ; Specific gravity of gas, 44 ; Atomic measure, 2 volumes ; Specific gravity of liquid, 0.89 ; Systematic name, Ethyla acetylete.

Prepared by distilling a mixture of 4 parts of acetic acid, 6 parts of alcohol, and 1 part of oil of vitriol. The distillation is stopped when

6 parts of liquid have passed into the receiver. It must be washed with water, and rectified from chloride of calcium. It is neutral to litmus. It has a burning taste, and an agreeable odour of apples. A small quantity of it seems to exist in some wines and affect their flavour. It is a good solvent for essential oils, resins, and pyroxilin.

Oxalate of Ethyl. Oxalic Ether.

Formula, C²H⁵,CO²; Equivalent, 73; Specific gravity of gas, 73; Atomic measure, 1 volume; Specific gravity of liquid, 1.023; Systematic name, Ethyla carbete.

Prepared by the rapid distillation of a mixture of 4 parts of alcohol of sp. gr. .825, 4 parts of binoxalate of potash, and 5 parts of oil of vitriol. A liquid, heavier than water, in which it is insoluble. Colourless. Has an agreeable ethereal odour and taste. Its boiling point is as high as 364°. The specific gravity of its gas is remarkable. The radical carbon being one of the kind that loses its atomic measure when acting as a constituent of a gaseous salt (see page 138), the equivalent of the salt is condensed into one volume, and its specific gravity coincides with its atomic weight.

Decompositions of Oxalic Ether.—These afford some interesting results.

1). With an excess of hydrate of potash it produces oxalate of potash and alcohol :—

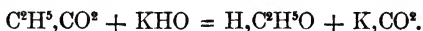

2). With an excess of the ether the products are alcohol and oxalovinic acid, a compound of the same category as sulphovinic acid (see page 486) :—

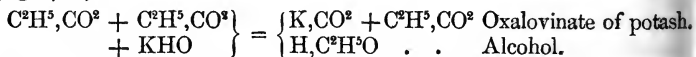

The oxalovinic acid $H,CO^2 + C^2H^5,CO^2$, is a binoxalate or double oxalate of ethyl and basic hydrogen, which hydrogen is replaceable by a metal, or any other basic radical.

3). With an alcoholic solution of ammonia added in excess, oxalic ether produces alcohol and oxamid (see page 378), and this forms a good process for preparing oxamid :—

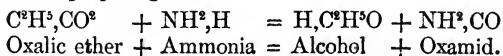

4). When the oxalic ether is in excess, the products of the decomposition are alcohol, and a beautiful solid soluble in alcohol, insoluble in water, and crystallisable into beautiful pearly tables, which has received the name of oxamethane, but which is the ethyl salt of the oxamic acid described at page 379 :—

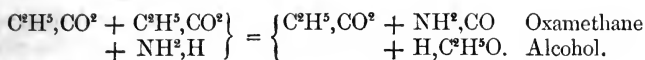

5). If equal parts of oxalovinate of potash and sulpho-methylate of potash are mixed and submitted to distillation, the product is a yellowish oil, of sp. gr. 1.127, which boils at 330° , and produces a vapour of sp. gr. 66, which is the double oxalate of ethyl and methyl:—

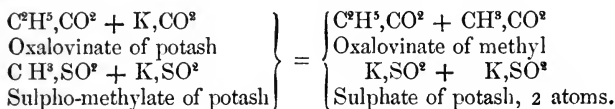

The atomic weight of the compound $\text{C}^2\text{H}^5, \text{CO}^2 + \text{CH}^3, \text{CO}^2$ is 132, and as its specific gravity is 66, its atomic measure is 2 volumes. Hence, the carbon has in this case also lost its atomic measure, and the measure of the double salt is merely that of its two basic radicals.

Other salts of Ethyl.—I cannot give room for farther details. It may be taken as a general rule, liable of course to occasional exceptions, that ethyl combines with all acids, and that its salts may be produced by distilling ether with any special acid, sometimes with the addition of oil of vitriol to take up hydrogen or water, the presence of which interferes with the action desired to be effected between the ethyl and the radical of the acid.

SALTS OF METHYL = CH^3 .

If the reader compares the list of salts of ethyl given at pages 145, 146, with the list of salts of methyl given at pages 147, 148, he will perceive a great family resemblance between them; and if I were to give a detailed account of the constitution, preparation, properties, and transmutations, of the salts of methyl, the account would greatly resemble that which I have given of the salts of ethyl between pages 477 and 489. But as my object is to give general views of organic chemistry, and not to teach the special history of each radical, I must here refrain from any other detail than is necessary to explain two or three particular compounds of the methyl series.

Methylic Alcohol. Wood Spirit. Pyroxilic Spirit.

Formula, $\text{H}, \text{CH}^3\text{O}$; *Equivalent*, 32; *Specific gravity of gas*, 16; *Atomic measure*, 2 volumes; *Specific gravity of liquid at 32°* , 0.82; *at 68°* , 0.8; *Systematic name*, Hydra methylate.

Wood-spirit cannot be prepared, like alcohol, by a process of fermentation. It is a by-product of the destructive distillation of hard woods (see page 433), and is found in company with the acetic acid and other fluid products of that distillation. These products, such as are

described at page 433 as being collected in the bent receiver, *b*, fig. 378, are rectified or re-distilled at the lowest possible temperature. By that means the wood-spirit is driven over, while the other compounds, which are only volatile at a higher temperature, are left behind. About 1 part in 16 is thus distilled over. The wood-spirit is then put into a retort with quicklime, and is again distilled. It passes over partially purified, and the retort retains the residue of the acetic acid, the water, and the tarry matters. To purify the wood-spirit still farther, it is saturated with chloride of calcium, and the product is distilled at a steam heat. The wood-spirit does not then rise, but other more volatile bodies pass away. The residue is diluted with water, which takes from the chloride of calcium the power to retain the wood-spirit. Heat being then applied, wood-spirit distils over, mixed with a little water. A final distillation with quicklime delivers it in a state of purity.

Properties of Methylic Alcohol.—It is a limpid, colourless, combustible liquid, having a disagreeable burnt taste and odour. These are so powerful that a small quantity has a great effect. This effect can be communicated to ethylic alcohol; and in consequence of that fact the British Government has allowed ethylic alcohol to be sold for use in the arts free of extravagant excise duty, provided it is mixed with as much methylic alcohol as spoils it for use as a beverage. Methylic alcohol is soluble in all proportions in water, alcohol, and ether. It mixes with essential oils and dissolves fats and resins, and is on this account used as a solvent of shell-lac, for the purpose of stiffening the solid part of silk hats.

Just as ethylic alcohol forms the basis of the compounds of ethyl, so methylic alcohol is the basis of the corresponding salts of methyl.

HYDRIDE OF METHYL.

Formula, H,CH^3 ; *Equivalent*, 16; *Specific gravity of gas*, 8; *Atomic measure*, 2 volumes.

Synonymes.—*Light carburetted Hydrogen*; *Gas of marshes*; *Fire-damp of coal-mines*. *Systematic name*, Hydra methyla.

Occurrence.—The gas of marshes is produced by the decomposition of organic substances in stagnant waters. It can be collected as follows:—Fill a flask with the marsh water, and, after inverting it in the water, put a wide funnel into its mouth and stir up the mud at the bottom of the water with a stick, holding the flask and funnel over the place that you agitate. The gas will then rise in bubbles into the flask and displace the water. The gas of marshes thus collected is accompanied by carbonic acid gas, which can be separated by putting lime-water into the flask, and shaking the mixture.

Marsh gas, with a minute admixture of spontaneously inflammable

phosphuretted hydrogen gas, produced by the putrefaction of animal matters, is the cause of the phenomenon called Will-o'-the-wisp.

This gas is also produced in coal-mines, and is the much-dreaded *fire-damp*, which, when mixed with atmospheric air and exposed to fire, explodes with extraordinary violence. Many persons are annually killed by such explosions, occasioned by the introduction of lighted lamps into the fire-damp. Accidents of this description are preventable by the use of the *Safety Lamp*, invented by Sir Humphry Davy.

The *Davy Lamp* is a common oil lamp, having the flame surrounded by a cage of wire gauze. *b*, in the figure, is the oil reservoir; *a* is the mouth by which it is filled, and which is closed by a screw; *e* is a wire moveable in an air-tight stuffing-box, by which the wick can be trimmed without opening the lamp. The principle of this lamp is as follows:—Davy discovered that flame cannot pass through wire gauze having more than 400 apertures to the square inch. This fact can be easily shown by means of a flat piece of fine iron-wire gauze of 8 inches square. If this is brought down over a gas-jet, and the gas lighted above it, the flame does not descend so as to inflame the gas between the jet and the gauze. If the gas is first lighted and the gauze brought down into the flame, the flame spreads below the gauze, but does not rise through it. At the same time the cooling action of the gauze upon the flame causes a quantity of gas to pass through the gauze unconsumed. Consequently, if a light is held above the gauze the gas inflames and then burns both below the gauze and above it. Upon this fact Davy

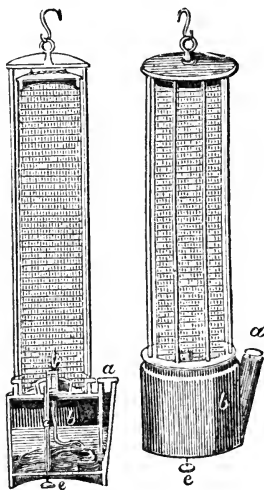

388.

reasoned, that if the lighted lamp came into an explosive mixture of fire-damp with air, only that quantity of the gas would burn which entered into the lamp, because the flame could not pass through the cage to inflame the large mass of surrounding gas; and so it proved in practice. Since this beautiful invention was adopted explosions in coal-mines have greatly diminished in frequency, and it is probable that the explosions which now too often occur are owing to a misuse of the lamp. The miners, for example, open the cage in order to get a stronger light. It might be an improvement upon the lamp to give it a window consisting of a number of thin, round plates of transparent mica about 2 inches diameter, closely screwed in a double round brass

rim, soldered to the lamp in front of the flame. This lamp would give much more light than the common form, and the mica would suffer little damage either from heat or wet.

Preparation.—1.) Mix 4 parts of crystallised acetate of soda, 4 parts of solid hydrate of potash, and 6 parts of quicklime in powder. Put the mixture into a gas-bottle of infusible glass, or a flask coated with a luting of fire-clay and borax, and apply a strong heat. Pure carburetted hydrogen gas is given off in abundance, and can be collected over water. The gas is derived from the decomposition of the acetic acid:—

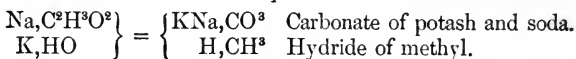

2). It can also be prepared from a mixture of $10\frac{2}{3}$ parts of hydrate of barytes and $10\frac{1}{3}$ parts of anhydrous acetate of soda:—

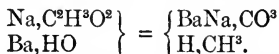

Properties.—A gas, specific gravity, 8; Atomic volume, 2. Colourless, tasteless, inodorous. Unable to support combustion or respiration, yet not poisonous. Insoluble in water. It burns readily in the air when lighted at a jet, and gives a bright yellow flame. Mixed with oxygen gas and inflamed it produces a violent explosion. It also explodes when mixed with atmospheric air and inflamed. The products of the combustion are water and carbonic acid:—

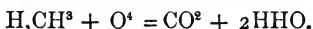

Hence 2 volumes of this gas take 4 volumes of oxygen gas or 20 volumes of atmospheric air to burn it, and the products are 16 volumes of nitrogen gas left by the atmospheric air, and 2 volumes of carbonic acid. This mixture constitutes the “after-damp” which is left by an explosion of fire-damp in a coal-mine, and being incapable of respiration is often fatal to those who breathe it after having escaped destruction from the violent explosion of the fire-damp.

A mixture of this gas with various properties of gaseous vinyl, CH^2 (see page 395), constitutes coal gas, of which some notice will be given in a subsequent section. See page 556.

Chloroform.

Formula, H, CCl^3 ; *Equivalent*, 119.5; *Specific gravity of gas*, 59.75; *Atomic measure*, 2 volumes; *Specific gravity of liquid*, 1.497; *Systematic name*, Hydra chlorinic-methyla.

Preparation.—1). Chloroform is produced when gaseous chlorine is mixed with gaseous chloride of methyl and exposed to the sun's rays:—

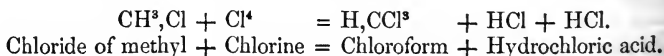

2). Chloroform is produced by the action of potash upon chloral. See page 446.

3). It is more economically prepared by the action of bleaching-powder upon dilute alcohol. It is manufactured on a large scale for use in medicine.

Chloroform affords, like chloral (page 446), an example of a compound containing a radical in which hydrogen is replaced by chlorine. It is a colourless, volatile liquid. Its taste is sweet, and it has an agreeable odour of ether. It is soluble in alcohol and ether, but scarcely in water. It dissolves sulphur, phosphorus, iodine, fats, resins, and caoutchouc.

Decompositions.—1). By a solution of potash in alcohol :—

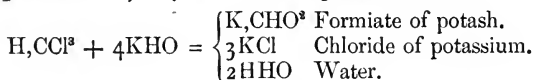

2). When distilled in a current of dry chlorine gas :—

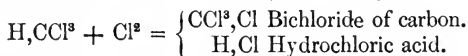

The compound commonly called bichloride of carbon would have the systematic name of chlorinic-methyla chlora. It is the chloride of the vice-methyl CCl^3 . It forms a gas whose specific gravity is 77, and its equivalent 154, so that its atomic measure is 2 volumes.

Chloroform in the state of vapour possesses the wonderful power of rendering a person who has respired it entirely insensible to pain. It is extensively used for this purpose to lessen human suffering during severe surgical operations. The vapours may be inhaled for this purpose from a small quantity of the liquid chloroform placed upon a sponge or a handkerchief, which is to be held before the nostrils and mouth. The chloroform must be perfectly pure, and the experiment should not be made except in the presence of a physician, who has had experience of the operation, who is satisfied of the purity of the chloroform, and who is acquainted with the constitution of the patient; for instances have occurred of death produced by the breathing of chloroform. The liquid should be colourless. It should give no colour when shaken with oil of vitriol. It should not smell of chlorine. When a few drops are rubbed on the hands and evaporated, no unpleasant odour should be left.

SALTS OF AMYL = C^5H^{11} .

The salts of Amyl have so great a resemblance to the corresponding salts of Ethyl and Methyl, that I may pass over all detail except that which refers to the source whence the radical is derived.

Brandy was originally spirit of wine, spirit really distilled from wine; but there is little doubt that a good deal of the spirit that now bears the

commercial name of brandy is the product of ingenious inventions applied to the manufacture of this spirit from fermented solutions of barley, of rye, and of potatoes. Certain it is that vast quantities of ardent spirit are made from these substances, and equally certain is it, that the spirit so produced can be greatly modified and improved in flavour and odour by means of the essences to which I have referred at pages 387 and 482. This manufacture is not without its difficulties. Potato spirit is not brandy, and when newly prepared and unsophisticated, it manifests the difference by a peculiarly offensive odour and taste. That offensiveness is due to the presence of a substance which is produced, like the spirit it accompanies, during the fermentation of the potatoes or grain from which the spirit is distilled. The removal of that substance is effected by the process of rectification, or slow re-distillation, at regulated temperatures. The raw spirit is a mixture of alcohol, of water, and of the compound which causes the mixture to stink. These are converted into vapour at different temperatures. Absolute alcohol boils at 173° F., water at 212° F., and the offending liquid at 270° F. The consequence of this difference in the boiling points of the mixed liquids is, that alcohol mixed with more or less water can be distilled at such a temperature as to separate it almost entirely from the liquid whose presence is so undesirable. To free the spirit entirely from the offensive taste and odour, it is distilled from, or passed through, a filter of freshly-burnt wood charcoal. The offensive liquor thus separated from potato spirit is called Amylic alcohol.

Amylic Alcohol. Potato Spirit. Fusel Oil. Fousel Oil.

Formula, $H_3C^2H^1O$; Equivalent, 88; Specific gravity of gas, 44; Atomic measure, 2 volumes; Specific gravity of liquid at 59° , 0.8184; Systematic name, Hydra amylate.

The residue of the rectification of crude spirit of wine referred to in the last paragraph is a mixture of water, alcohol, amylic alcohol, and acetic acid. If it is diluted with water, and agitated, the amylic alcohol rises to the top of the liquid in the form of an oil. It is to be purified by rectification from caustic potash.

Amylic alcohol is a colourless, limpid liquid, which has a greasy feel, a burning taste, and a penetrating and oppressive odour. It boils at 270° , and freezes to crystalline plates at -4° . Very little soluble in water, but mixes in all proportions with alcohol, ether, and the essential oils. It is neutral to litmus. The vapour is very irritating when respired. A drop placed on the tongue produces coughing, and a feeling of disgust, giddiness, faintness, and loss of power in the lower extremities; and these unpleasant feelings are not wholly removed within 24 hours. Small animals are killed by it. The counter-poison for it is ammonia. It is difficult of combustion, and burns with a bluish flame.

From this liquor the salts of amyl are produced by processes analogous to those described in reference to the salts of ethyl and methyl.

Thus, if you mix together 2 parts of acetate of potash, 1 part of fusel oil, and 1 part of oil of vitriol, and boil the mixture in a test-tube, you immediately perceive the agreeable smell of pear-oil, which is produced by the acetate of amyl = $C^5H^{11}, C^2H^2O^2$. If the mixture is distilled in a retort, and the vapour passed into water, you will perceive this compound collect in oily drops upon the water.

But this is not all. Just as the radical ethyl can be reduced from C^2H^3 to C^2H^2 , and be made to produce *acetates*—just as methyl CH^3 , can be reduced to CH , and be made to produce *formiates*, so can amyl be reduced from C^5H^{11} to C^5H^9 , and be made to produce *valerianates*. See page 453.

Here, then, we perceive some of the wonderful consequences of chemical combination. The alcohols of methyl and amyl are extremely offensive both to taste and smell; so are the hydrated butyric and valerianic acids. Yet when these burning, biting, stinking things combine with one another, the products are the series of essences (see page 387) which give odour and flavour to our choicest fruits and liqueurs—to pears, apples, quinces, and pine-apples—to rum, brandy, hock, and tokay. The phlegms and refuse of breweries and distilleries become the sweets and spirits of confectioneries and perfumeries.

THIRD SERIES OF EXAMPLES OF ORGANIC SALTS.

THE VINYLATES, OR SACCHARINE COMPOUNDS.

I have shown, at page 384, the probable origin and the nature of sugar, and the theoretical relations which its most important compounds bear to one another. I may give, in this place, a few particulars respecting their properties, modes of occurrence, extraction, and transformations.

a). THE SUGARS.

Cane Sugar = $C + (CH^2O)^{11}$.—This is the sweetest and most soluble of the different varieties of sugar, and that which can be procured from the plant in which it grows most readily, most economically, and in the greatest abundance. It is procured, however, not only from the sugar-cane, but in America from the sugar-maple, and in France from the beet-root. It exists in many other vegetables, from which it cannot be extracted economically, such as carrots, turnips, the pumpkin, the chestnut, &c.

When crystallised it has a sp. gr. of 1.6. It is soluble in about one-third of its weight of cold water, producing a thick liquid, called syrup. The following table shows the percentage of sugar in some solutions:—

Specific Gravity.	Sugar in 100 parts.	Specific Gravity.	Sugar in 100 parts.
1000	.00	1152	.35
1020	.05	1177	.40
1040	.10	1204	.45
1062	.15	1230	.50
1081	.20	1257	.55
1104	.25	1284	.60
1128	.30	1321	.67

Sugar readily forms crystals, which are called *sugar-candy*. The sugar-loaf is a mass of small white brilliant crystals. When two pieces of sugar are rubbed together in the dark, a phosphorescent light of a pale violet colour is produced. When a solution of sugar is boiled, it soon becomes sour. The presence of any free acid promotes this acidification. The sugar thus acted upon loses its power to crystallise, and is converted into fruit sugar or vinylate = CH^2O . To prevent the loss which is thus occasioned, lime is added to the expressed juice of the sugar-cane before it is evaporated for crystallisation. The lime serves also to precipitate some albuminous substances derived from the cane, and which are injurious to the sugar. In the West Indies this operation of liming is performed with very little care. The late Dr. Shier showed that by properly *testing* the cane-juice according to the rules of chemistry, and regulating the admixture of lime according to the knowledge obtained by the testing, at least *one-fifth* could be added to the weight of marketable sugar produced from a given quantity of juice, and the whole quantity be so much improved in quality as to command a better price in the English market. See *Directions for Testing Cane Juice*, by Dr. JOHN SHIER. London, 1851.

Strong sulphuric acid chars and destroys sugar. See page 46. A small quantity of sugar contained in a solution may be discovered by a test depending upon a similar property of some chlorides. Dip strips of white merino into a diluted solution of stannic chloride, and dry them at 212°F . If a drop of dilute syrup is placed on one of these prepared slips, and is gently heated, a brown or black stain will be produced. The starch and fruit sugars also act in this way. Under the influence of yeast, cane sugar is converted into alcohol and carbonic acid. See page 343. In contact with putrefying cheese, sugar passes into the lactic fermentation, and produces lactic acid. If fused at 320°F . it produces *barley-sugar*. If the heat is raised to 400°F ., the product is a brown substance, called *caramel*, which is used by confectioners, cooks, and brandy-makers as a colouring matter.

Cane sugar is distinguished from some other kinds of sugar by two reactions, one depending upon the fact that its solutions exert a right-handed rotation upon a ray of polarized light, while some other kinds, but not all other kinds, of sugar exercise a left-handed rotation. This reaction requires a particular form of polariscope for its observance. The other reaction is that which it exercises on a solution of copper, and which gives rise to a process of centigrade testing, which is described in most large works on chemistry or on sugar.

Fruit Sugar. Fructose. Vinylate. CH^2O .—This kind of sugar exists ready formed in honey and in most ripe acidulous fruits. It can also be prepared from most of the compounds of vinylate, $\text{C} + (\text{CH}^2\text{O})^n$, such as starch, gum, or cellulose, by acting upon them with diluted sulphuric acid. The odd atom of C takes up O^2 , and is disengaged, and the compound vinylate is reduced to its simplest form, CH^2O . When its solution is made neutral by the addition of carbonate of barytes, and is evaporated, it forms crystals of grape sugar, which differs from fruit sugar, which is not crystallisable, by the accession of a small proportion of water:—

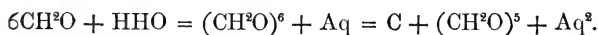

Sometimes fruit sugar passes spontaneously into grape sugar. Thus, the fruit sugar of fresh grapes crystallises into grape sugar in dried raisins. It seems to me, however, that the differences of these sugars have not been very clearly made out.

Glucose. Starch Sugar.—The name *grape sugar* is often applied to this kind, and nearly as often to fruit sugar. Its formula is

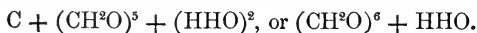

The starch sugar is prepared from starch as follows:—Water, containing 1 per cent. of sulphuric acid, is made to boil, and into this boiling water is slowly poured a fluid mixture of starch and water, previously warmed to 120°F . The mixture must be kept boiling while the starch is being added; and after the starch is all added, it must be gently boiled for half an hour, by which time the starch will be converted into sugar. During the boiling a peculiar odour is perceptible, which is due to the disengagement of fusel oil. With 100 parts of water, 50 parts of starch are used. The liquid is drawn off, and the acid is neutralised by the addition of chalk. It is then allowed to settle, and the solution is poured off and evaporated down to sp. gr. 1.28. Being then allowed to settle, it deposits some crystals of sulphate of lime; and it is then set aside to crystallise, which it does after some days.

Conversion of Woody Fibre into Sugar.—As the constitution of wood is the same as that of starch, so can it also be converted into sugar. Two parts of fine linen rags are to be ground up in a porcelain mortar with three parts of oil of vitriol. The mixture is to be set aside for

twenty-four hours, and is then to be largely diluted with water, and to be boiled for six hours. By that time syrup is produced, and can be separated from the acid by chalk and filtration, as described above.

From the above reactions it is seen that, though oil of vitriol destroys cane sugar, it does not, when diluted, destroy the other kinds of sugar, but acts as a useful agent in producing them from other forms of vinylate.

Refining of Sugar.—Two or three parts of sugar are dissolved in one part of lime-water, mixed with three or four per cent. of bone-black. The mixture is heated by steam, and is filtered through cloth bags. The reddish liquor thus procured is afterwards filtered through beds of powdered animal charcoal or bone-black (see page 327), and the filtered liquor is then evaporated for crystallisation. This is a process of considerable difficulty, and is effected by means of elaborate apparatus, for a description of which I cannot give space.

Sugar of Milk.—Formula, CH^2O , or $\text{C} + (\text{CH}^2\text{O})^4 + \text{HHO}$. When dried, it becomes $\text{C} + (\text{CH}^2\text{O})^4$. Also called *Lactin* and *Lactose*. To procure this compound from milk, convert the milk into curds and whey, separate the curd, boil the filtered liquor to separate albumen, again filter, and concentrate the whey by evaporation, until it reaches the crystallising point. Then hang in it some pieces of wood, upon which crystals of lactose will be deposited. The crystals are white, translucent, and hard; soluble in five or six parts of water; insoluble in alcohol and ether. When boiled with dilute acids, lactose is converted into fruit sugar.

b). THE STARCHES AND GUMS.

Starch. $\text{C} + (\text{CH}^2\text{O})^5$.—This composition is equal to five atoms of vinylate plus one atom of carbon. Compare it with the other compounds of vinylate, page 384. It occurs in the form of oval or rounded grains, never crystalline, in the cellular tissue of different parts of plants, and in a great variety of different plants. Thus it is found in peas and beans, in the seeds of wheat, oats, barley, and other grains, in the potato, in the roots of the tapioca and arrow-root, in horse-chestnuts, &c. The grains of starch appear to differ considerably in size, and somewhat in form, in different plants. They all consist of little cells or bags, in which the meal or true starch is contained, each of which cells seems to have a point by which it was attached to the plant, of which it formed a part, and by which it received its supply of nourishment. It is easy to perceive the slight change by which vinylate, a solution of which in water constitutes the blood of plants, is converted during the ripening of the plant into starch. Thus:—

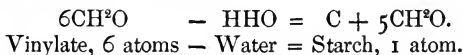

The forms of the grains of starch can be distinguished with a microscope

that magnifies 300 or 400 diameters. With such a microscope, aided by a polariser, interesting observations can be made on the starches. The structure of the grains can be beautifully developed by the following experiment:—On an object-glass of the microscope place a drop of a concentrated solution of chloride of tin, slightly tinged with free iodine. Into this put some grains of starch. No change is evident till water is added. The grains then turn blue, and gradually expand until some of them acquire twenty- or thirty times their original bulk. During this expansion the skin appears to unfold a number of plies, and when fully expanded looks like a flaccid sac.

Starch is insoluble in cold water, in alcohol, and in ether. But in water heated to 150° F. the granules absorb water and swell up, and the mixture is converted into a viscous mass, commonly called *starch paste*. If this mixture is greatly diluted, the swollen grains sink down, but a quantity of starch remains in solution. If this solution is evaporated, the dry residue does not recover its former insolubility in cold water. A solution of starch produces right-handed rotation of a ray of polarised light.

Potato Starch.—Rub some clean potatoes to a pulp on an iron grater. Mix the pulp with water; place it on a sieve or a piece of stretched cloth, and put the sieve on a pan under a gentle run of water (as, for example, from a water-bottle, page 238); stir the pulp about, upon which a milky liquor will run from the sieve into the pan, and an insoluble fibrous mass will remain in the sieve. When the milky liquor has settled an hour, the starch will be deposited at the bottom of the pan, and the water may be poured off and preserved for subsequent examination. Fresh water is stirred up with the starch, allowed to settle, and then poured off, and this washing is repeated till the water passes off colourless. The starch may then be mixed with water, and run through a finer sieve, and finally be dried at a very low heat.

Vegetable Albumen contained in Potatoes.—The first liquor that is poured from the starch contains those constituents of the potato that are soluble in cold water; among these is vegetable albumen. Boil the liquor in a glass flask or a beaker, upon which it will deposit a flocky greyish matter, which can be separated by filtration. This is the albumen, a nitrogenised body, which is soluble in cold and in warm water, but is coagulated by boiling water. Albumen occurs abundantly in oily seeds, such as almonds, rapeseed, linseed, poppy seed, &c.

Burn a little of the albumen on a slip of platinum foil. It will develop an ammoniacal odour, which indicates the presence of nitrogen, and it is thus discriminated from starch.

Colouring Matter in Potatoes.—A fresh-cut potato is quite white, but it gradually becomes brown. The expressed juice of the potato, or the first liquor poured from the starch, gradually turns brown. This is the case with many vegetable substances. The seeds of the sweet-pea have a

bright-green colour when a pod, not quite ripe, is opened ; but after a few hours' exposure to the air and light they become of a dark-brown colour.

Starch from Peas.—Soak a handful of peas for some days in water till they are quite soft. Pound them in a mortar with as much water as will make a thin paste. Pass this paste through a linen cloth, or rub it on a sieve. The result will be as with the potatoes ; a milky liquor will pass through the cloth, and woody fibre will remain within it. The liquor, on settling, will deposit starch, and the clear liquor will be found, when boiled, to deposit vegetable albumen. The starch must, as before directed, be washed and dried.

Vegetable Casein in Peas. Legumin.—The first liquor separated from the peas-starch, and by subsequent boiling and filtration from the albumen, is to be mixed with a small quantity of acetic acid, upon which a white flocky substance will be precipitated. This is vegetable casein (curd or cheese), a compound nearly related, in composition and properties, to the curd or cheese procured from milk. It is rich in nitrogen. It is distinguished from albumen by not being coagulated by boiling water, and by curdling in the presence of an acid. Vegetable casein is abundant in peas, beans, lentils, and other legumes. It is thence sometimes called *Legumin*.

Starch from Wheat.—Mix a handful of wheat flour with as much water as will make a stiff paste or dough. It may be worked with the hands or in a mortar. Tie the dough in a piece of thick linen cloth. Put a pan under a gentle stream of water, and knead the bag of dough between your hands under the water as long as the water flows from it milky. From that milky liquor starch is deposited when it rests.

Gluten in Wheat.—On opening the cloth from which the starch has been pressed, you find a grey, sticky, tough, tasteless substance, like birdlime, which consists in part of woody fibre, but mainly of gluten or vegetable fibrin, a compound which is very rich in nitrogen, and which, partly for that reason, and partly from its tenacity, qualifies wheaten flour to make good bread. It occurs in all descriptions of corn. When dried, it forms a hard, brown, horny mass.

Albumen in Wheat.—If the water first decanted from the wheat starch is boiled in a flask until it is somewhat concentrated, it deposits a small quantity of flocks of albumen.

Comparison of the Substances furnished by Potatoes, Peas, and Wheat.

	Free from Nitrogen.	Containing Nitrogen.
Potatoes	{ Starch	Albumen.
	{ Woody fibre	Casein, <i>a little</i> .
Peas	{ Starch	Albumen.
	{ Woody fibre	Casein, <i>much</i> .
Wheat	{ Starch	Albumen.
	{ Woody fibre	Gluten, <i>much</i> .

Detection of Sulphur in Albuminous Vegetable Substances.—Boil 50 grains of pounded peas, with 30 grains of caustic potash, in an ounce of water, and from time to time apply drops of the boiled liquor to lead test paper. This paper is white, but has the property of turning black when wetted with a liquor which contains a soluble sulphide. After some boiling, the potash will decompose the peas, and produce sulphide of potassium, which will blacken the test paper. When this blackness becomes decided, add to the mixture a few drops of sulphuric or hydrochloric acid, which will set free sulphuretted hydrogen = HS, a gas easily recognised from its offensive odour of rotten eggs. Gluten and albumen both yield this result.

When Nitrogenous Compounds rot and decay, they disengage Ammonia, Carbonic Acid, and Sulphuretted Hydrogen.—Put into a flask a little gluten or some crushed peas, cover them with water; connect the flask by a gas-leading tube with a second flask, containing a small quantity of clear lime-water, into which the tube must dip; put between the cork and the neck of the first bottle a long slip of lead test paper, so that it hangs freely over the liquor in the flask; put the apparatus in a warm place.

After some time the gluten or peas will decay; sulphuretted hydrogen will be produced, and will turn the lead paper black; carbonic acid will be produced, and will give a precipitate in the lime-water; and the liquor in the first flask will smell of ammonia, and, if poured off and mixed with a solution of caustic potash, it will disengage ammonia freely.

Starch from other Vegetables.—It may easily be produced from horse-chestnuts by proceeding in the same manner as with potatoes. It is also procurable from maize and rice.

Sago.—The pith of the sago-palm yields a starch which undergoes a sort of preparation at a steam heat, which produces sago. An imitation of the foreign sago is prepared as follows:—Apply a gentle heat to moistened starch contained in a capsule, under constant stirring, till it becomes dry. The starch aggregates under this treatment into hard horny lumps, which, when afterwards mixed with boiling water, swell up and produce a semitransparent jelly resembling true sago.

Tapioca, arrow-root, and salep are names given to varieties of starch prepared from various plants.

Test for Starch.—Starch produces an intense blue colour when it meets with free iodine. Dilute a drop of starch solution, and add to it a little tincture of iodine: the solution will acquire a deep blue colour. If the liquor is boiled, the colour disappears, but it returns when the liquor cools. If the tincture of iodine is dropped on flour, potatoes, and other amylaceous compounds, it produces this characteristic blue colour.

Constitution of Boiled Potatoes and Baked Bread.—The composition of 100 parts of raw potatoes is represented in the following table:—

	Moist.	Dried.
Water	75.9	—
Albumen	2.3	9.6
Oily matter	0.2	0.8
Woody fibre	0.4	1.7
Starch	20.2	83.8
Salts	1.0	4.1

When the potato is boiled, the watery juice is absorbed by the cells of starch, which become distended, and the albumen is coagulated by the heat, and serves to bind together the particles of starch by a sort of network. By this means the watery juice of the potato is converted into a solid substance of a light porous texture. In the same way water mixed with flour and baked into bread becomes consolidated by the starch of the bread, so that the baked bread weighs more than the flour of which it is made. These properties of starch explain the great expansion which occurs during the boiling of many of our articles of food, such as rice, groats, barley, beans, peas, &c.

The pores of bread are produced by the formation and liberation of carbonic acid gas in the plastic dough. The production of this gas is due either to the action of yeast upon the starch sugar of the flour, or to the action of hydrochloric acid upon carbonate of soda, both mixed with the flour and water employed to form the bread. When yeast is used, the action is exactly like that which I have described at page 343, in the article on Fermentation. With every equivalent of carbonic acid which is produced, an equivalent of alcohol is formed and wasted, while three equivalents of sugar are destroyed. See page 344. That is a great loss to the bread; and it has also been urged against the use of yeast as a leavening material that, when it is of bad quality and used in excess, part of it can withstand the destroying action of the oven, and, making the bread liable to a subsequent fermentation, cause it to be unwholesome.

As the sole use of yeast appears to be that of liberating carbonic acid gas, this purely chemical effect can be easily produced by inorganic materials, which do not destroy the sugar of the dough. When hydrochloric acid acts upon carbonate or bicarbonate of soda, the sole products are carbonic acid gas and common salt, both of which are equally required in the bread. The materials are cheap, and the way of handling them is easy. But sufficient chemical knowledge must be at command to enable the baker to proportion the acid to the salt, and sufficient care must be taken to insure purity in the materials, because if the hydrochloric acid of commerce, which often contains arsenic, were thoughtlessly used for this purpose, the result would be the introduction of arsenic into the bread. In the section on "arsenic," I shall show how the purity of the hydrochloric acid can be tested.

The action of hydrochloric acid upon carbonate and bicarbonate of soda is as follows:—

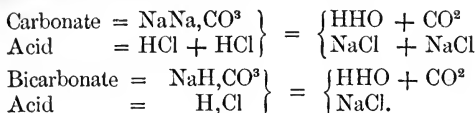

In the first case, the liberation of 44 grains of carbonic acid is accompanied by the production of 117 grains of salt. In the second case, the liberation of the same quantity of carbonic acid is accompanied by the production of only $58\frac{1}{2}$ grains of salt. A comparison of these facts will enable the baker to see which of the compounds would best suit his object, or whether a mixture of the two salts would be preferable to either alone. It may be necessary to disengage 44 grains of carbonic acid gas in a certain quantity of dough to insure a sufficient degree of lightness or porosity; but for the resulting quantity of bread, 117 grains of salt may be too much, and $58\frac{1}{2}$ grains too little. The proportions will probably vary according to the quality of the flour, and the experience of the baker must guide him. If 44 grains of carbonic acid are desirable, and 108 grains of salt are sufficient, that result will be procured by liberating half the carbonic acid from carbonate, and the other half from bicarbonate of soda. The relation of the carbonates of soda to one another has been fully explained at page 354. The purified hydrochloric acid could easily be tested by the centigrade process, and have its strength so regulated by dilution as always to be of known quality in reference to the kind of carbonate of soda adopted for use in the bakehouse. The proportions of both could be so exactly regulated, that neither acid nor soda nor salt should ever appear in the bread in excess.

British Gum.—Roasted starch acquires the property of dissolving in cold water, and forming a sticky liquid resembling a solution of gum. This preparation is much used by calico printers to thicken their coloured solutions and convert them into a species of ink suitable for the mechanical operation of printing on cloth.

Dextrin = C + (CH²O)⁵.—Make a thick paste by boiling potato starch with water. Put this into a porcelain capsule, and stir into it while hot a few drops of sulphuric acid. The thick paste will soon become a thin fluid. Place the capsule, *b*, over a water bath, *a*, fig. 389, and keep the water boiling in the bath until the mixture in the capsule becomes transparent. The mixture itself must not be made to boil. When the liquid becomes clear, chalk is to be added cautiously until the mixture ceases to be acid to test-paper. It is then to be removed from the furnace, the sulphate of lime is

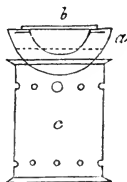

389.

to be separated by filtration, and the liquor is to be put in a warm place to dry up. The residue is a brittle, glassy solid, with little taste. It dissolves in water to a transparent, slimy solution, similar to that produced by the *Gums*. It is not soluble in alcohol. It does not give a blue colour with tincture of iodine. Its name is due to its producing a right-handed rotation upon a ray of polarised light. If the solution of dextrin in the sulphuric acid water is made to boil, it is converted into starch sugar. Dextrin is the principal ingredient of British gum.

Catalytic action of Sulphuric Acid.—I have shown, at pages 497 and 503, that sulphuric acid, in small quantities, acting with warm water, changes starch into dextrin, and dextrin into glucose. These three compounds have the same formula = $C + (CH^2O)^5$, but very different properties. The sulphuric acid, which causes the change in properties, loses nothing and gains nothing by the reaction. When saturated by chalk, HSO^2 becomes $CaSO^2$, as well after as before its action on the sugar. This power of effecting chemical changes by mere contact, and without participation in the changes, has been called *catalytic action*. This, however, is only a name for the phenomenon and not an explanation of it.

Malt.—To prepare malt, barley is steeped in water until it becomes soft, which requires from forty to sixty hours, during which the water is changed two or three times. The barley swells considerably, and increases nearly one-half in weight. It is then drained, and placed in heaps upon the floor of the malting-house for twenty-four hours, during which it increases in warmth, and begins to grow. It is then spread over the floor of a dark room for about a fortnight, being turned over with wooden shovels two or three times a-day. The temperature is kept at about 60° F. By this time the root of the grain has extended about half an inch. The grain is then spread upon perforated metal plates, and air heated to 90° is passed through the heap for some hours to dry it. Heat is then applied below the metal plates, and the malt is dried at 140° ; or if it is to be *high dried*, for the purpose of making porter or dark-coloured beer, it is heated at a still higher temperature. By this means the vitality of the seed is destroyed. Ten parts of barley yield about eight parts of malt. During the process, oxygen is absorbed and much carbonic acid given off, and a considerable change is effected in the constitution of the barley. This originally consists chiefly of starch and gluten; but during the germination of the seed the starch undergoes a species of fermentation, and is converted first into dextrin and subsequently into sugar; in which state it becomes the food of the growing sprout. This transformation is due to the action of a peculiar substance called *Diastase*, which is produced in all germinating seeds. In malt it exists in the proportion of 1 part in 500. Yet this minute proportion is sufficient to produce great effects. 1 part of diastase will convert 2000 parts of starch first into dextrin and ultimately into sugar.

This powerful action of diastase enables the brewer to dispense to a certain extent with the operation of malting, because experience shows him that the diastase contained in one part of malt will transform into sugar the starch contained in four parts of unmalted barley.

Diastase.—Pour four ounces of warm water over half an ounce of coarsely-pounded malt; expose the mixture for some hours to a gentle heat, and then filter it through a linen cloth. This extract of malt contains a small quantity of diastase. This compound, as stated above, will, like diluted sulphuric acid, convert starch into dextrin and dextrin into sugar.

a). *Conversion of Starch into Dextrin by Diastase.*—Prepare starch paste with half an ounce of potato-starch and four ounces of water. Bring this paste to the temperature of 150° F., using the apparatus, fig. 389, and stir into it about one ounce of the extract of malt containing diastase. Keep the mixture at that temperature until it becomes transparent and thin fluid. Then raise the heat till the mixture boils, and after a few minutes strain it through a linen cloth and put it in a warm place to dry up. The product is dextrin.

b). *Conversion of Starch into Sugar by Diastase.*—With the other three ounces of the extract of malt act upon starch paste in the same manner, only with the difference that a gentle heating, at from 150° to 160° , must be continued for several hours. Dextrin is first formed, but this is converted by continuance of the heat into sugar. The temperature of 150° is most favourable for the production of sugar. At a boiling heat, the action of diastase is destroyed.

From these experiments it appears, that in the mash process, or the preparation of wort for beer, it is the action of diastase which converts the starch of the barley and malt into sugar. It is the subsequent vinous fermentation of the beer, by means of yeast, which converts the sugar into alcohol. During the early growth of plants from seed, the diastase gradually converts the starch into sugar, and so feeds the plant, until leaves are formed, to constitute the electrical batteries, by which the water and carbonic acid of the atmosphere are converted into vinylate for the subsequent sustentation and development of the plant.

How the quantity of Starch contained in the Potato varies according to the time of year.—I have given, at page 502, a note of the proximate composition of the potato. The following table shows the varieties in the per centage of starch of one particular kind of potato when examined at different times of the year :—

In August	10 per cent.	In January	17 per cent.
September	14 „	February	16 „
October	15 „	March	15 „
November	16 „	April	13 „
December	17 „	May	10 „

In autumn, as the potato advances to maturity, the saccharine juice is converted by the vital force into starch. In winter, the vital force is dormant, and the per centage of starch remains for some time unchanged, unless frost takes place. In spring, the vital force awakens, and the per centage of starch diminishes, in consequence of its conversion into sugar. It is well known that when the potato begins to grow, it becomes soft, slimy, and sweet. These signs betoken the presence of dextrin and sugar. The process of change goes on in the earth, all the starch is turned into the blood of plants, and the residue of the potato provides, by its decomposition, carbonic acid, water, and ammonia, to feed the growing plant.

The Ripening of Fruit is accompanied by the conversion of Starch into Sugar.—Unripe apples and pears are turned blue by tincture of iodine. Ripe and sweet fruits are not turned blue. We may infer thence that the starch is turned into sugar.

Frost conduces to the conversion of Starch into Dextrin and Sugar.—When potatoes have been frost-bitten, they become slimy and sweet.

Gums.—The account that has been given of dextrin shows that gum holds a middle place between starch and sugar. Gums occur in many plants. When fruit trees, especially cherry and plum trees, have had their branches cut, gums in large quantity exude in glassy drops at the wound, between the wood and the bark. The general presence of gum in plants leads to the idea that it is an intermediate stage by which the vinylate, or juice of plants, proceeds from the state of sugar to the states of starch and fibre.

Gum Arabic. Arabin. $C + (CH^2O)^{11}$.—The most important and most characteristic of the gums is gum arabic, which consists of transparent drops exuded from an African acacia. It is soluble in water, with which it produces a tasteless, slimy liquor, the sticky qualities of which render it useful as a paste or glue. It is not susceptible of the alcoholic fermentation. It is convertible by sulphuric acid into dextrin and sugar. It is insoluble in alcohol, so that the latter forms a precipitate in an aqueous solution of gum.

Mucilage.—This is a modification of gum, which does not dissolve in water, but swells with it into an extremely bulky, soft, sticky, glutinous mass. *Gum tragacanth* is the best example of a gum consisting of mucilage. Cherry-tree gum consists in part of true soluble gum, but chiefly of mucilage. This substance also occurs in linseed and in marsh-mallow root.

Vegetable Jelly.—This principle, like starch and gum, pervades vegetables extensively. It is that which gives to many fruits and to the extracts of many roots the power to gelatinise. It is very well known, practically, to good housewives, who concern themselves with the preparation of jams and jellies. Chemists have sometimes called it Pectin and Pectic acid, and sometimes enumerated many varieties of

Pectin, but it does not appear to be thoroughly understood. It occurs not only in fruits, but in carrots, turnips, parsnips, &c.

c). WOODY FIBRE. LIGNEOUS STRUCTURE.

The power of life slumbers in every grain of corn, in every pea, in the minutest seed, in the eye of every potato. Heat and moisture waken it up, give it active energies, and produce a result so wonderful, that the more we examine it and reflect upon it the greater becomes our astonishment and admiration. "The grain of mustard seed, which is the least of all seeds, when it is grown, is the greatest among herbs, and becometh a tree, so that the birds of the air come and lodge in the branches thereof."

The common garden bean consists of two lobes, or cotyledons, which contain the means of nourishment for the young plant. The plumule, or embryo plant, is a small white point between the upper part of the lobes, from which proceeds the radicle, or young root. The matter of the seed when examined in its common state appears dead and inert; it exhibits neither the forms nor the functions of life. But if it is acted on by moisture, heat, and air, its organised and slumbering powers are speedily developed. The cotyledons expand, the membranes burst, the radicle acquires new matter, descends into the soil, and the plumule rises towards the fresh air. By degrees, the organs of nourishment of dicotyledonous plants become vascular, and are converted into seed leaves, and the perfect plant appears above the soil. Nature has provided the elements of germination on every part of the surface of the soil. Water, air, carbonic acid, ammonia, and heat, are brought by the atmosphere, and the means for the preservation and multiplication of life are at once simple and grand.

The plant having produced leaves, and a root, is then in a condition to act upon the materials provided by the atmosphere and by the soil to form vinylate, the juice or blood of plants, and the plant supplied with this material has, by means of other agencies, the power of converting vinylate into dextrin, into starch, into salts of the multitudinous acid and basic radicals which we have taken into consideration, and into the substance which gives coherence, mass, strength, and form to the growing plant—into its woody fibre or ligneous structure.

Cellulose = $C + (CH^2O)^5$.—The cells and vessels of living plants consist of woody fibre, for which reason that substance is called *cellulose*. Woody fibre is for plants, what bones, muscles, and skin are for animals. It gives them solidity, form, mass, strength, individuality. But it does more, it forms on the roots and on the leaves of plants the mouths by which it receives the water, carbonic acid, and ammonia, which are its food. It produces the vessels in which these materials are converted by chemical and electrical forces into sugar, and the series of sap vessels by

which the sugar is circulated through the plant, converted as occasion requires into starch, dextrin, or cellulose, and deposited as such in those positions which the vital force prescribes for the good of the plant.

Pure cellulose is a white substance without taste, insoluble in water, alcohol, ether, and oils. It is heavier than water. It exists in a fibrous state, and the fibres are transparent. Cold oil of vitriol dissolves it, and produces a thick fluid, which at first contains dextrin and ultimately starch sugar. The purest cellulose that can be obtained is fine cotton, linen, and pure filtering-paper. Cellulose is not coloured blue by iodine; but after it has been a little acted upon by sulphuric acid, it gives a blue colour with iodine, so that the action of the acid is to pass cellulose through all the conditions of starch, dextrin, and sugar.

The purest natural cellulose is found in cotton, linen, elder pith, rice-paper. Its physical characteristics and appearances vary in different plants. It is soft, eatable, and digestible in the young leaves of flowers and stalks of plants, and in the flesh of certain fruits and roots, such as apples, plums, turnips, and potatoes. It is hard and unfit for food in the state of straw, wood, the husks of seed, and the shells of fruit. In the wood of trees it is hard and compact; in nut-shells it is yet harder and denser; in flax, cotton, and hemp it is flexible and tough; in tubers and roots it is loose and spongy; in the pith of elder and in cork it is porous and elastic.

That the wood of trees does not consist of pure cellulose can be easily proved by experiment. Soak a quantity of sawdust in warm water for twenty-four hours. Press the liquor from the sawdust through a cloth, and boil the clear liquor in a flask, upon which it will be slightly troubled, and on cooling will deposit a small quantity of vegetable albumen. See page 499. The liquor, filtered from the albumen, contains small quantities of several other principles, such as mucilage, gum, tannin, &c. If the sawdust is dried and then digested with spirit of wine, it yields resin and other substances not soluble in water, and even after that, ether and other solvents would still extract some matters, none of which belong to cellulose, but all of them to other vegetable compounds which existed in the tree when it was felled.

Gun Cotton. Pyroxilin.—Mix equal parts of the most concentrated nitric acid, sp. gr. 1.5, and the most concentrated sulphuric acid. Into fifteen parts of that mixture (placed in a porcelain evaporating basin under a chimney with a good draught) plunge one part of finely-carded cotton. Immerse the cotton completely and immediately under the acid, and press it down with a pestle. After five minutes' soaking, lift it out with a glass rod, and plunge it into a large quantity of water, to wash off the acid. Change the water frequently, until the cotton, when laid upon blue litmus paper, ceases to turn it red. Squeeze the cotton as dry as possible with the hand. Spread it out on a sheet of paper in a cool place to dry. It is dangerous to warm it.

Any kind of cellulose may be treated in the same way, such as paper, linen, tow, or sawdust; but fine cotton and pure filtering-paper act best. No change of appearance takes place in the cotton, but a great change is effected in its chemical constitution and properties:—

Composition:

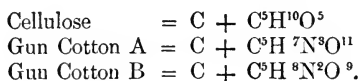

Two other, much more complex compounds, were found by analysis to exist between those marked A and B, namely, $A + 2B$, and $2A + B$, but they were probably only mixtures of these two kinds. We have in this transformation an example of the displacement of hydrogen by nitrogen, (see page 413,) and in accordance with the usual law, each atom of nitrogen carries with it into the new compound two additional atoms of oxygen. As to the proximate constitution of these compounds, nothing decisive is known. The gun-cotton A is made with the most concentrated acids. It is highly explosive, soluble in acetic ether, and insoluble in mixtures of alcohol and ether. The compound B is prepared with weaker acids, and is scarcely explosive. It is soluble in ether. For a particular account of different varieties of gun-cotton, consult HADOW, *Quarterly Journal of the Chemical Society*, vii. 208.

The most remarkable property of gun-cotton is the facility with which it burns when heated or struck by a hammer. A temperature below 400° is sufficient to explode it. When fired in the open air, it makes a flash and is completely consumed without smoke or report. If fired in a gun, instead of gunpowder, it explodes much more violently than gunpowder, but it does not propel a ball so far as a charge of gunpowder would propel it. The extreme facility and violence with which gun-cotton explodes, makes it a dangerous thing upon which to experiment. It is harmless when soaked in water and kept wet.

Collodion.—This is a solution of pyroxilin in a mixture of ether and alcohol. When this mixture is poured upon an even surface, as a plate of glass, it spreads into a thin layer, the solvent evaporates, and the film produced is employed in the process of photography. The gun-cotton which makes the best collodion, is said to be that which has the formula $(\text{C} + \text{C}^5\text{H}^8\text{N}^2\text{O}^9) + 2(\text{C} + \text{C}^5\text{H}^7\text{N}^3\text{O}^{11})$. This is prepared by means of an acid mixture containing 89 parts by weight of nitric acid, sp. gr. 1.424, and 104 parts by weight of sulphuric acid, sp. gr. 1.833. The gun-cotton thus produced is soluble in a mixture of 8 parts of ether with 1 part of alcohol, and insoluble in acetic acid. When the acids are stronger than the above proportions, the gun-cotton produced is more explosive and less soluble.

The action of heat on woody fibre will be explained in the section on combustion and fuel.

FOURTH SERIES OF EXAMPLES OF ORGANIC SALTS.

COLOURING MATTERS.

The blossoms of plants exhibit a multitude of colours of inimitable beauty, but which are for the most part so transient, that they wholly disappear when the blossoms are dried. The beautiful green which gladdens our sight over the whole surface of the vegetable world, cannot be extracted for use in the arts. If it were soluble in water, the rain would wash it from the trees and meadows, and leave them colourless and cheerless. The colours which can be extracted from vegetables for practical purposes are found in all the organs of plants. In the roots, in the wood, in the bark, in the petals, or the anthers of flowers, in berries or in seeds. In some instances, the colours which are made use of do not appear in the plant, but result from the chemical transformations which are occasioned during their extraction or preparation. Most organic colours fade away under the action of sunshine, moisture, and air. They are promptly destroyed by the action of oxide of hydrogen, HO, and by chlorine. Many of them are also bleached when exposed to sulphurous acid. The extraction of colouring matters is usually effected by water, often at a high temperature. In some cases, alcohol is employed as a solvent, but more frequently solutions of alcalies, because the colouring matters either contain, or consist of acid radicals. It is a consequence of their containing such radicals that their solutions have the power to form precipitates with solutions of salts of lead, alumina, and tin; precipitates which frequently have very brilliant colours, and are known by the name of *Lakes*. In the arts of dyeing and calico-printing, these lakes are formed on the cloth, the metallic base being first applied as a mordant, and the colouring matter subsequently superadded.

Yellow Dyes.

Curcumin, from the root of *Curcuma longa*, a resinous substance, nearly insoluble in water; soluble in alcohol and ether; soluble in acids, retaining its yellow colour; soluble in alcalies, which change the colour to bright brown. Commonly called *Turmeric*. Paper tinged yellow with it is a common test in chemical laboratories for alcalies, by which it is rendered brown. It is not so delicate a test as litmus. It is used in the arts for dyeing wool and silk, and to colour curry powder.

Quercitron, the bark of the *Quercus tinctoria*, contains a feeble acid = $\text{H}_2\text{C}^8\text{H}^8\text{O}^5$. *Old Fustic*, or *Morus tinctoria*. Used to dye woollens yellow, or in conjunction with indigo and salts of iron, to produce greens and olives. With alum and carbonate of potash, its solutions give a yellow lake. *Young Fustic*, or *Rhus cotinus*, gives a different yellow dye. With acetate of lead, it produces an orange-coloured lake. *Saffron* consists of the anthers of the flowers of *Crocus sativus*. Its chief use is to give colour to liqueurs and to confections for eating.

Annatto, prepared from the seeds of the *Bixa orellana*. Used to dye nankeen. *Rhubarb*. The root yields a yellow colour, which is changeable to reddish-brown by a slight trace of free alkali. *Weld*, or *Reseda luteola*, yields a yellow colour, much valued for its durability. *Persian berries*, the fruit of the *Rhamnus*, contain a brilliant yellow colour. *Gamboge* is the dried juice of *Garcinia gambogia*. Its use in water-colour painting is well known. It is a powerful purgative, and seems to be the basis of most of the pills advertised by quack doctors as a remedy for all diseases and a security for long life. The yellow dyes are chiefly used with blues to produce greens and olives. They have been to some extent superseded by chrome yellow, which gives a very brilliant and more durable colour.

Red Dyes.

Madder is the root of the *Rubia tinctorium*. It is used in enormous quantities for dyeing red. The finest and most durable red which can be produced on calico, termed Turkey red, owes its brilliant colour to this root. Madder has undergone much chemical examination, and several colouring principles have been extracted from it. That which is esteemed to be the true red dye is called *alizarin*.

Logwood is the wood of an American tree, the *Hæmatoxylin campechianum*. Much used for dyeing blacks, violets, and blues, with different mordants, such as alumina and iron. Acids change its colour to red. Its colouring principle can be extracted without much difficulty. Mix the powdered wood with quartz sand, and digest it with five or six times its volume of ether for several days. Then distil off the ether till the residue thickens like syrup. Mix this residue with water and set it aside in a vessel loosely covered. Crystals of *Hæmatoxylin* will be produced. These appear in the form of long, narrow, four-sided, brilliant-yellow, transparent needles. It is sparingly soluble in cold water, freely in boiling water, in ether, and in alcohol. It is coloured blue by alkalies. If a drop of its solution is placed on a flat porcelain plate, and a drop of liquid ammonia is placed at a distance, on the same plate, the hæmatoxylin soon assumes a beautiful purple colour.

Brazil Wood.—The wood of the *Cæsalpina Braziliensis*. The decoction in water dyes cloth with a beautiful but very fugitive red. Acids give the solution a bright lemon colour, and alkalies change it to violet or purple. With alumina it produces *red ink*.

Safflower is obtained from the petals of the *Carthamus tinctorius*. It contains a useless yellow dye, and a fine red dye. The latter is called *Carthamin*. It is this colour which forms the *Pink Saucers*, and it is employed to produce a beautiful and brilliant rose-red colour on silk.

Carmine is obtained from *Coccus cacti*, the colouring matter of the insect called *Cochineal*. The powdered insect is treated with ether to remove fat, a solution is then made with water, and precipitated with

acetate of lead. The precipitate is well washed, mixed with water, and decomposed by sulphuretted hydrogen, which precipitates the lead. The filtered solution is evaporated to dryness over sulphuric acid in vacuo. See page 284. The product is *carminic acid* ($C^7H^7O^4$). It is a purple-brown mass, easily soluble in water and alcohol. Dissolves unchanged in sulphuric and hydrochloric acids, but is immediately decomposed by nitric acid and chlorine, which produce yellow compounds. Fixed alcalies change the aqueous solution to purple. With alum and ammonia a beautiful crimson lake is produced. With salts of tin a bright crimson solution is produced. Cochineal is extensively employed with salts of tin as a scarlet dye for woollen cloth. *Lac dye* is nearly related to cochineal.

Sandal Wood and *Alkanet Root* produce red dyes with alcohol. They are too fugitive to be of much importance.

Blue Dyes.

Litmus, *Cudbear*, and *Archil*.—The colouring matters known in commerce by the names of Litmus, Cudbear, and Archil, are prepared from various descriptions of lichens. They dye very beautiful, though very fugitive, shades of red, violet, and blue colours upon silk, and have been much employed for that purpose. Perhaps the new *mauve* colour, which is said to be fast, will interfere with their future use. Litmus is, beyond all other colours, most easily changed by chemical reagents. All acids redden it. All alcalies turn it blue. If it is so prepared that its solution gives a pale purple tint when spread upon pure paper, that colour is reddened by the most feeble acids, and turned blue by the feeblest alcalies. No other colour affords a test of equal delicacy. The preparation of delicate test-papers is rendered difficult by the impossibility of obtaining hard paper which is entirely free from acid.

Indigo.—This colouring matter is prepared in India and America from the leaves of various plants of the *Indigofera* tribe. The *Isatis tinctoria*, or common *woad*, also yields indigo in small quantity. It is the most important of the blue colouring matters. It does not exist ready formed in its plants, the juices of which are yellow, but is formed during the process of manufacture. It is a nitrogenous compound; all its salts containing nitrogen, though its essential radical seems to be a hydrocarbon, $Indyl = C^9H^8$. See page 411. I have investigated its compounds very minutely, and shown their relations by formulæ. See "*The Radical Theory in Chemistry*," page 257. I can only quote two or three examples of indigo compounds.

Indigo Blue, or *Indigotine* = NH^2, C^9H^8O . An amidogen salt, in which $Indyl C^9H^8$ is the acid radical.

Indigo White, or *Reduced Indigo* = $NH^4, C^9H^8O + NH^2, C^9H^8O$.

Sulphate of Indigo = $H, SO^2 + NH, C^9H^8$; SO^2 .—This is a double

sulphate produced by dissolving indigo blue in concentrated sulphuric acid. Thus:—

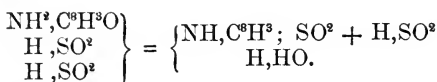

Preparation of pure Indigo Blue.—Put a small quantity of powdered indigo between two watch-glasses that are ground to fit together closely. Apply a gentle heat. Much of the indigo will be destroyed, but a portion will form brilliant copper-coloured crystals of pure indigo.

Preparation of Sulphate of Indigo.—Indigo blue is insoluble in water, alcohol, and ether; but it is soluble in concentrated, or in fuming, sulphuric acid. The indigo should be ground fine, and be put with the concentrated acid into a stoppered bottle, and be placed in a warm situation for 24 hours, being frequently shaken. If the acid is diluted, or the mixture is exposed to the open air, so as to be able to absorb water, another compound of sulphuric acid is produced with indigo, which has a purple colour, and is not soluble in water. There should be enough indigo present to saturate the sulphuric acid. The liquor so prepared is used to dye cloths Saxony blue. Much diluted with water, the solution of indigo is often used in physical experiments to render water visible in glass vessels. The sulphate of indigo contains one atom of basic hydrogen, which is replaceable by a metal. Thus, with potash it produces an insoluble salt called blue carmine:—

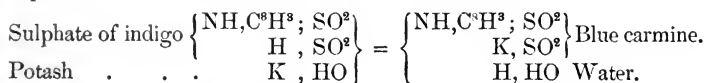

Preparation of Indigo White.—Indigo blue is converted into indigo white, which is a soluble substance, by the application of what are called reducing agents, by which, in this case, is meant such as can communicate to indigo blue a quantity of hydrogen. Compare the formulæ given above. Rub 30 grains of indigo blue with 60 grains of ferrous sulphate in crystals, and 90 grains of slaked lime. Put the mixture into a four-ounce stoppered bottle; fill it with water, put in the stopper, and set it aside for some days. The indigo gradually loses its blue colour, and dissolves into a clear yellow solution. Several reactions concur to produce this metamorphosis. Firstly, the lime reduces the ferrous sulphate, producing gypsum and ferrous hydrate:—

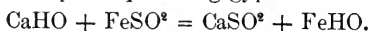

The precipitated ferrous hydrate has a strong tendency to become ferric hydrate, and with it is present indigo blue, which has a strong tendency to take up hydrogen, in order to become indigo white. These double tendencies operating together occasion the decomposition of water and the liberation of hydrogen, as follows:—

Ferrous hydrate, 4 atoms = $\text{Fe}^4\text{H}^4\text{O}^4$ } = { $\text{Fe}^6\text{H}^6\text{O}^6$ Ferric hydrate, 6 atoms.
 Water, 2 atoms = $\text{H}^2\text{H}^2\text{O}^2$ } = { H^2 Hydrogen, 2 atoms.
 See *Theory of Reduction*, page 155.

These two atoms of hydrogen serve to convert one equivalent of indigo blue into one equivalent of indigo white. The excess of lime is usually described as acting merely as a solvent of the indigo white. It may, however, form a definite ammonium compound with indigo-white. Thus:—

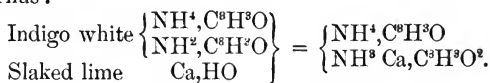

The yellow solution produced as above described is called by dyers the *Copperas Vat*, and is used to dye cottons and linens blue. The solution of reduced indigo, if exposed to the air, rapidly takes up oxygen, to which it gives up its acquired hydrogen, and again becomes insoluble indigo blue. Thus, if a piece of white filtering paper is dipped into the solution, and then exposed to the air to dry, it first becomes green and then blue, the colouring matter adhering firmly to the paper. The same result is produced when cotton yarn or calico is immersed in the liquor and then air-dried. The blue thus produced is very intense, because thoroughly wrought into the fibres of the cloth, and very permanent, because blue indigo is insoluble in all ordinary solvents.

Experiments with Colouring Matters.

1). Digest sandal-wood with spirit of wine, and filter the solution. A slip of wood dipped into this solution acquires a fine blood-red colour. In Germany the wood of furniture is often stained of this colour, previous to being polished. The colouring matter of sandal-wood is a resin, and insoluble in water.

2). Prepare decoctions of Persian berries, Brazil wood, and log-wood, by boiling each with 12 times its weight of water in a glass flask or a porcelain basin. The decoction of the Persian berries is yellow; that of the Brazil wood yellowish-red; that of the log-wood brownish-red. These colours are all soluble in water.

3). Put a little of each decoction into a separate beaker glass, add to each a solution of alum, and then a solution of caustic potash, as long as it produces a precipitate. The coloured substances thus thrown down are *Lakes*, or colours in which alumina acts as a base, and the colouring matters as acids. The potash is to neutralise the acid of the alum.

4). Prepare solutions of a) alum, b) stannic chloride, c) ferrous sulphate, d) caustic potash, and e) tartaric acid. Dip into each of them a slip of white filtering-paper, and dry it. Cut each slip into three pieces, and dip one slip of each preparation into the yellow dye, the red dye, and the blue dye prepared as directed in experiment 2); after dip

ping, dry them all. It will be seen that every slip has a different tint of colour. The comparison will be helped by dipping into the dye liquors slips of the same paper, *f*), without previous preparation. Dry the papers, and lay them in warm water. The colours will dissolve from the slips prepared as directed *d, e, f*, but not from those prepared as directed *a, b, c*. The salts by which these slips were prepared, namely, alum, stannic chloride, and ferrous sulphate, are termed *mordants*. As substances possessing the power to fix colouring matters upon the fibres of silk, wool, cotton, and linen, so as to be insoluble and irremovable, these mordants are of vast importance in the arts of dyeing and calico-printing. In dyeing, the steps of process 4) are followed. The goods are first saturated with the mordant, and are then exposed to the colouring extract. In calico-printing, the mordant is printed in figures, and the printed fabric is then dyed; in which case the dye adheres only to the printed figures.

FIFTH SERIES OF EXAMPLES OF ORGANIC SALTS.

ESSENCES AND RESINS.

The odours of most plants are due to compounds which agree with the formulæ H, R^n ; H, R^nO ; H, R^nO^2 ; and R^p, R^nO^2 , namely, to hydrides, aldehydes, and acids of hydro-carbon radicals, or to salts of those acids with volatile basic radicals. There are, however, considerable difficulties attendant upon their examination; one of these arising from the circumstance that several substances, essentially different in their characters, have the same ultimate composition. I have no space to enter here upon intimate details, but must confine myself to generalities.

The essences fall into two classes, the simple hydro-carbons H, R^n , and those which contain oxygen.

In some respects they resemble the fat or fixed oils. They are inflammable, sparingly soluble in water, readily soluble in alcohol and in ether. They are volatile, either alone or in company with the vapour of water. For these reasons they are called *Volatile oils*. They differ from the fixed oils in several respects; they feel harsh and not unctuous to the fingers, and the grease-stain which they make upon paper is driven away by heat. They occur in different parts of plants; in seeds, in flowers, in the skin of fruits, in the leaves of the plant. Sometimes they are extracted by pressure, but more generally by distillation with water. Though in a pure state they commonly boil at a higher temperature than 212° , yet in the presence of steam or water at that heat their volatility is increased, and they distil nearly at the boiling point of water. The method of conducting the distillation of volatile oils is explained between pages 239 and 243. All such distillations should be conducted with caution, to prevent accidents from fire or explosion.

A. HYDROCARBONS.

Essence of Turpentine. Oil of Turpentine. Spirit of Turpentine.
Formula C^5H^9, C^5H^7 . *Atomic weight*, 136; *Specific gravity of vapour*, 68;
Atomic measure, 2 volumes; *Specific gravity of liquid*, 0.864.

This composition is equivalent to valeryl (C^5H^9) plus angelyl (C^5H^7), or camphoryl (C^5H^7). There is, however, no means of proving that this suggested composition is correct. A general survey of its related compounds renders it probable.

Different species of pine tree, when wounded, exude a soft resin. An example of such resin may be examined in Venice turpentine, which is the resinous exudation of the larch. When this resin is distilled with water it gives essential oil or essence of turpentine, a volatile, limpid, very inflammable liquor, possessing a peculiar, well known, balsamic odour. What remains in the retort is the solid substance called *rosin*, or *colophony*.

Oil of turpentine boils at 320° , and is not altered by distillation. It mixes with alcohol and ether, but not with water. It dissolves essential oils, fixed oils, and resins, and is highly useful in the preparation of *varnishes*, for the solution of resin being brushed evenly over any object, loses its turpentine by evaporation, and leaves a transparent coating of resin upon the surface of the varnished object. Oil of turpentine also dissolves sulphur, phosphorus, and caoutchouc. When rectified over lime or soda it is purified from resin and from water, and is called *camphine*, and under that name is used as fuel for a particular description of lamp

Volatile Oils, nearly related to Turpentine in constitution, though different in odour and other properties.

Bergamotte Oil.—From the rind of the ripe fruit. Besides the hydrocarbons C^5H^9, C^5H^7 , it contains a solid substance $C^3H^2O^1$, which may be an aldehyde H, C^3HO , or possess some other equivalent composition. All these volatile oils are subject to become oxidised, and are no doubt convertible into aldehydes and acids.

Oil of Lemons.—From the rind of the lemon and orange.

Oil of Neroli.—From the blossoms of the orange tree.

Oil of Birch.—From the tar of birch-bark. Gives odour to Russian leather.

Essence of Camomile, C^5H^9, C^5H^7 ; also contains H, C^5H^7O .—When treated with hydrate of potash, this oxidised portion disengages hydrogen, and is convertible into angelate of potash:—

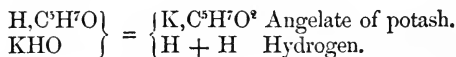

Essence of Juniper.—Its oxidised portion = C^5H^9, C^5H^9O .

Oil of Carraway.—Its oxidised portion, called *Carvole*, is C^5H^7, C^5H^7O . This, with hydrochloric acid, yields a liquid camphor

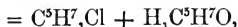

which is a compound of a chloride with an aldehyde of the same radical.

Oil of Cloves.—From pimento and cloves.

Oil of Ginger.—Intensely burning and aromatic.

Oil of Cubebs.—The composition of the hydrocarbons of this oil is, according to per centage, the same as that of the preceding oils = $C^{10}H^{16}$, but it should probably be stated thus:—

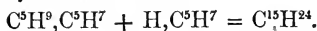

With hydrochloric acid it produces corresponding compounds:—

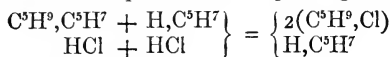

By oxidation the transformation is similar:—

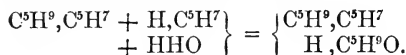

Essence of Capivi.—Distilled from balsam of capivi. Also supposed to contain $C^{15}H^{24}$, and its crystalline hydrochlorate to be $C^{15}H^{24} + 3HCl$. The first of these formulæ is equal to $C^5H^9, C^5H^7 + H, C^5H^7$, and the second, divided by 3, is C^5H^9, Cl , the hydrogen of the hydrochloric acid being just enough to convert all the C^5H^7 into C^5H^9 .

Essence of Hops is said to be a mixture of the compound C^5H^9, C^5H^7 , with a compound called valerole = $C^6H^{10}O$. This is equivalent to C^5H^9, CHO , showing valeryl and formylate. When treated with caustic potash it produces valerianate and carbonate of potash, giving off much hydrogen:—

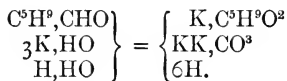

Essence of Valerian contains the same substances as *Essence of Hops*, with some others.

Oil of Thyme contains C^5H^9, C^5H^7 , and its oxidised portion is thymole = $H, C^{10}H^{18}O$. This may, however, be considered as the oxide of one of the hydrocarbons $H, C^{10}H^{18}O = C^5H^7, C^5H^7O$.

B. OXIDISED ESSENCES.

Camphor.—There are several varieties of camphor, all of which are nearly related to the turpentine; that is to say, the radicals which form the turpentine, when oxidised, form the camphors.

Laurel Camphor = C^5H^9, C^5H^7O . Atomic weight, 152; Specific gravity of gas, 76; Atomic measure, 2 volumes.—This is the common camphor of the shops, derived from the *Laurus camphora*. Many of the volatile

oils, which contain the radicals $C^5H^9 + C^5H^7$, produce camphor when oxidised. In the first preparation of camphor, it is rudely distilled from the chopped wood. A second distillation produces the blocks which are found in commerce. It is afterwards refined by sublimation from lime in glass globes.

Camphor evaporates and exhales an odour at ordinary temperatures. If small fragments are placed in water, they swim about with a rotatory movement, and rapidly evaporate. A drop of essential oil placed on the water stops this. The peculiar odour of camphor is known to most people. It is tough, but can be readily pulverised in a mortar if moistened with a few drops of alcohol. Its sp. gr. is .996. It fuses at 347° , and boils at 399° . Very inflammable; burns with a white smoky flame.

Experiment.—Suspend a coil of red-hot platinum wire over a lump of camphor. The metal continues to glow, and causes a slow but continuous combustion of the camphor.

Borneo Camphor = C^5H^9, C^5H^9O .—This substance is so highly prized in Japan as a remedy for rheumatism, that scarcely any of it comes to Europe.

Essence of Bitter Almonds. Hydride of Benzoyl. H, C^7H^5O .—To prepare this essence, pound some bitter almonds, macerate them in water for two days, and then distil the mixture, using a retort and a good condensing apparatus. There is produced a fragrant oily liquid, heavier than water, which contains the essence of bitter almonds, but also hydrocyanic acid, benzoic acid, and benzoine. This liquor is much used in perfumery in consequence of its peculiar and very powerful odour; but it is extremely poisonous, in consequence of the hydrocyanic acid which it contains. The kernels of the peach, the plum, the cherry, and other stone fruit, and the leaves of the laurel, yield this essence in notable quantities. To purify the crude essence, it must be shaken with a mixture of milk of lime and solution of ferrous chloride, and then be re-distilled. What passes over is pure $H, C^7H^5O = Hydra benzylate$. See page 475. This is not poisonous. It is inflammable, and gives a smoky flame. It is soluble in 30 parts of water. It boils at 356° . In contact with air it is converted into benzoic acid $H, C^7H^5O^2$. When heated with hydrate of potash it yields hydrogen and benzoate of potash,

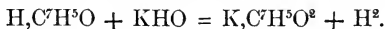

As the radical benzoyl C^7H^5 is very permanent, and endowed with extensive powers of combination, this essence is capable of producing a vast variety of compounds.

Essence of Cumin. Hydride of Cumyl. Hydrate of Cumyl. Formula, $H, C^{10}H^{11}O$; Atomic weight, 148; Specific gravity of gas, 74; Atomic measure, 2 volumes.—When the seeds of the *Cuminum cyminum* are distilled with water they give over a distillate which contains the

hydrate of cumyl = $H, C^{10}H^{11}O$, and a hydrocarbon = $H, C^{10}H^{13}$, the hydride of thymyl. They are separable from one another, and the essence of cumin can be transformed into a variety of compounds, such as $H, C^{10}H^{11}O^2$ = cuminic acid; $H, C^{10}H^{13}O$ = cuminic alcohol, but which ought to be called thymylic alcohol; $C^{10}H^{11}O$ = cumyl, properly oxide of cumyl; $K, C^{10}H^{11}O$ = cumylide of potassium.

Essence of Cinnamon. Oil of Cinnamon. Hydride of Cinnamyl. Formula, H, C^9H^7O .—Produced by the distillation of cinnamon and cassia. It can be transformed into cinnamic acid $H, C^9H^7O^2$.

Storax yields a compound called Styrene, or cinnamic alcohol = H, C^9H^9O . This name is improper, because the radical C^9H^9 is styryl, not cinnamyl. Styracin, also called metacinnamene, has the formula $C^{18}H^{16}O^2$. This is procured, in company with cinnamic acid, from the Balsam of Peru, and from it the alcohol H, C^9H^9O is obtained. Styracin ought to be formulated thus: $C^9H^9, C^9H^7O^2$. It is the cinnamate of styryl.

Oil of Spiræa. Salicylous Acid. Hydride of Salicyl. Formula, $H, C^7H^5O^2$; Equivalent, 122; Specific gravity of gas, 61; Atomic measure, 2 volumes; Specific gravity of liquid, 1.173.—Procured by distilling the flowers of the meadow-sweet, *Spiræa ulmaria*. When pure it is a colourless oil. It decomposes carbonates with effervescence, and produces crystallisable salts, both neutral and acid, according to the formulæ $M, C^7H^5O^2$, and $M, C^7H^5O^2 + H, C^7H^5O^2$. It is isomeric with Benzoic acid, but it is unknown what difference there is in their proximate constitution. The radical *salicyl* has the formula C^7H^4 , and the name of this radical C^7H^5 ought to be *spiryl*.

Essence of Garlic.—The distilled oils produced by garlic, onions, leeks, cress, radishes, and assafœtida, contain as a principal ingredient the sulphide of Allyl = C^3H^5, S .

Essence of Mustard.—This is produced by the distillation of black mustard-seed, after being crushed and digested with cold water. It is also the cause of the pungency of horse-radish and scurvy-grass. The active chemical substance present in this essence is the Sulphocyanide of allyl = $C^3H^5, S + CyS$.

C. RESINS.

The resins appear to be sub-oxides of the radicals which mainly form the respective essential oils, or of the radicals which result from the partial dehydrogenation of these radicals. Thus, oil of turpentine is C^5H^9, C^5H^7 , and the resin left by its distillation is C^5H^7, C^5H^7O ; while some resins appear to be C^5H^9, C^5H^9O , and others to be compounds of these with hydrides C^5H^7, H , or with aldehydes H, C^5H^7O .

They are amorphous, brittle solids of various shades of yellow and brown, semitransparent to opaque. Insulators of electricity, and negatively electric by friction. Easily fusible; combustible; burn with a

white, smoky flame. They are insoluble in water, but soluble in alcohol. Those which consist of acid radicals dissolve in alkaline leys, and produce a species of soap.

The resins are either produced by oxidation of the essential oils of certain plants, or they are the residues left by the evaporation of essential oils from natural resins. When they are heated to decomposition in close vessels, their radicals split up into a great variety of new compounds.

Common Rosin. Colophony.—Left by the distillation of turpentine. It enters largely into the composition of yellow soap.

VARNISHES.—The resins that are mostly employed in the manufacture of varnishes are Copal, Mastich, Sandarach, and Lac.

The solvents for resins employed in the manufacture of varnishes are oil of turpentine, wood spirit, and spirit of wine. The resins are powdered and mixed with broken glass, to prevent their baking into lumps. A good varnish for maps and paintings is formed by 24 parts of mastich, 3 of Venice turpentine, and 1 of camphor. These substances are mixed with 10 parts of pounded glass, and dissolved in 72 parts of rectified oil of turpentine.

Lac.—Lac is one of the most important of the resins. It is found in commerce as stick-lac, seed-lac, and shell-lac. It exudes from the branches of various tropical trees. Lac is much used as a stiffening for hats. It is the main ingredient in good sealing-wax; the common sorts being made of rosin. Mix 48 parts of shell-lac, 12 parts of Venice turpentine, 1 part of Balsam of Peru; melt at a gentle heat, and work into the mixture 36 parts of vermilion. This produces sealing-wax of fine quality. Lac is an important ingredient in hard varnishes.

Lacquer: 2 parts of lac, 1 part of sandarach, and a small quantity of Venice turpentine, dissolved in 20 parts of alcohol, produce a lacquer for brass and bronzed objects.

Balsams.—The balsams are natural mixtures of resins with essential oils. Such are Canada balsam and balsam of copaiba. Some of them contain the essential oils and aromatic acids which have already been noticed, namely, balsam of benzoin, tolu, storax, and Peru.

Gum Resins are the milky juices of many plants solidified by exposure to air. They are important as medicines. The following are among them: ammoniacum, scammony, aloes, galbanum, gamboge, myrrh, and assafœtida.

Caoutchouc. Indian Rubber.—The solidified milky juice of many tropical plants. As prepared for sale, it contains not only pure caoutchouc, but the albumen and other ingredients of the juices of the plants from which it exudes. The composition of pure caoutchouc is probably equal to C^4H^7 . Its sp. gr. is .92 to .96. It is very elastic, especially when warm. Insoluble in water, but softens in boiling water. Not acted upon by alcalies. Chlorine scarcely attacks it. Diluted nitric

and sulphuric acids are inert, but when they are concentrated they decompose it.

Caoutchouc readily dissolves in the following liquors: Anhydrous ether, chloroform, xanthy, coal naphtha (mineral naphtha), and rectified oil of turpentine. From these solvents it can be separated with preservation of its original properties. It can also be dissolved in the fixed oils, but it cannot be recovered from them unchanged.

Waterproof cloth is formed by applying liquid caoutchouc to the surfaces of two pieces of suitable cloth, and then pressing the prepared surfaces together by rollers.

Vulcanised Caoutchouc.—When caoutchouc in sheets is dipped into melted sulphur at 250° , it absorbs from 12 to 15 per cent. of sulphur. If it is then heated for a few minutes at 300° , but not above that temperature, it produces the elastic compound called vulcanised caoutchouc, which is now extensively used in sheets and pipes for innumerable purposes. The clean edges of vulcanised caoutchouc do not adhere together like those of pure caoutchouc; but, on the other hand, it has the advantage, that tubes do not collapse and stick together when they are not required to do so.

Gutta Percha.—Gutta percha is the concrete juice of the *Isonandra percha*, a tree which grows abundantly in the Indian Archipelago. It is a tough and flexible, but not elastic substance. At a moderate heat, under 212° , it becomes perfectly elastic, and can be pressed, like wax, into any desired form, which at mean temperatures it retains, becoming hard and horny. Separate pieces can, if dry, be welded together by heat, and so extremely ductile is it, that it can be made to copy the finest mouldings or engraving with the most perfect fidelity. When cold, it is hard and tenacious. When rubbed, it becomes negatively electric. When dry, it is an excellent electrical insulator, and is on that account used to cover the wires of telegraphs. If a thin sheet is rubbed with a fur it becomes so strongly electrical that it can be used instead of a pitch-plate as an electrophorus. See page 207. Gutta percha has been usefully employed as soles for shoes, as waterproof materials, as pipes for conveying water, and as bands for driving machinery.

The circumstance that gutta percha can be readily squeezed into the form of various utensils, which do not break, and which resist the action of the most corrosive liquors, renders it extremely useful in the arts.

It is quite insoluble in water. It is soluble in benzole, chloroform, xanthy, turpentine, and in most essential oils. Hydrochloric acid and hydrofluoric acid do not act on it. It is therefore used for bottles to contain hydrofluoric acid. Concentrated nitric acid destroys it rapidly, and oil of vitriol slowly.

Experiments with Essences and Resins.

1. Warm $\frac{1}{2}$ an ounce of Venice turpentine in an earthen pot till it is

a thin fluid; pour it into a gas-bottle of about 10 ounces capacity, add 4 ounces of water, adjust a gas-leading tube to carry the steam into a bottle carefully cooled by condensing water, and apply heat to distil over about 3 ounce measures. Take the cork from the flask, and pour the residue in it while hot into cold water. The distilled liquor consists of water, with spirit of turpentine floating upon it. The solid residue in the cold water is resin. The process of distillation is fully explained in the article at page 236.

2. Pound in a mortar half an ounce of carraway-seeds; mix with 4 ounces of water, and distil over two ounce measures. The light oil which gathers on the water is oil of carraway. For the method of separating such oils from water, see page 242, article "Florentine receiver." The distillation may be made with a flask, or with a retort and condenser.

3. Heat spirit of turpentine in a retort or flask, through the neck of which a thermometer can be placed. The boiling point will be found at about 320° F., whereas water boils at 212° . This difference is shown by many oils. If oils take fire, the vessel should be covered to exclude oxygen, without which the oils cannot burn. If water is cast upon burning oil, the high temperature converts it into steam with explosive violence. If volatile oils are mixed with water, and then heated, they rise together in vapour at a temperature near to that of boiling water.

4. Dip a slip of wood into oil of turpentine, and hold it to a light. It readily burns with flame. If the cotton wick of an oil lamp, which, when damp, lights with difficulty, is moistened with a few drops of oil of turpentine, it takes light readily.

5. Alcohol, mixed with one-eighth part of oil of turpentine, burns in a spirit-lamp with a bright luminous flame without smoke. This flame has a strong heat, and serves for glass-blowing.

6. The volatile oils are only slightly soluble in water, but sufficiently so to give taste and odour to it. They are easily soluble in alcohol; most of them in spirits of 80 per cent. of alcohol. A few of them, that contain no oxygen, require absolute alcohol. Most of the beverages which pass under the name of *liqueurs* are prepared in the cold way by adding essential oils to alcohol. Formerly, these were prepared by soaking the seeds, blossoms, leaves, &c., of plants in brandy, and then distilling the mixture.

7. In half an ounce of alcohol dissolve a few drops of the oils of bergamotte, orange-flowers, lavender, and rosemary. The mixture will have a most agreeable odour. It affords an example of the process by which the innumerable scents of the perfumer are prepared, among the most celebrated of which is *Eau de Cologne*. Similar solutions are employed in medicine; thus, spirit of camphor is a solution of camphor in alcohol.

8. Aromatic vinegar may be prepared by dissolving in strong acetic

acid a few drops of the essential oils of cloves, cinnamon, bergamotte, and thyme.

9. Similar solutions of essences can be made with ether.

10. The fat oils and the fatty acids dissolve or mix with the essential oils and produce odoriferous mixtures, more or less solid, known as hair-oils and pomatums.

In the preparation of all kinds of perfumery care must be taken to avoid *rancidity*, that is to say, to avoid those fatty acids which possess *per se* an evil odour, and so overpower the odour of the essential oils. When fats become rancid they can often be deprived of rancidity by washing with hot water, in which the fatty acids whose odour is rancid are soluble.

11. If a piece of loaf-sugar is rubbed over the skin of a lemon or orange, it breaks the cells that contain the essential oil, and absorbs the oil into its pores.

12. *Marine Glue*.—Dissolve some chips of caoutchouc in mineral naphtha, with which it forms a stiff paste. When this paste is melted with shell-lac it forms a very durable cement for wood, stone, iron, &c.

13. Caoutchouc easily takes fire, and burns with a bright smoky flame; at the same time, it melts to a black slimy mass. This melted caoutchouc is usefully applied to prevent the fixing of glass stoppers in bottles which contain alkaline leys; for if the stopper is smeared with it the caoutchouc retains its slipperiness for a considerable time, and the smeared stopper remains moveable.

ORGANIC COMPOUNDS THAT CONTAIN NITROGEN.

THE ULTIMATE ANALYSIS OF THE ORGANIC COMPOUNDS WHICH CONTAIN NITROGEN.

I have explained at page 371 the processes of destructive analysis by which chemists determine the relative properties of the carbon, hydrogen, and oxygen, which are contained in an organic compound. The carbon is supplied with oxygen to convert it into carbonic acid, which is collected and weighed. The hydrogen is supplied with oxygen to convert it into water, which is also collected and weighed. Of the carbonic acid, 12 parts in 44 are carbon: of the water, 2 parts in 18 are hydrogen. The quantity of oxygen is found from the loss sustained. That is to say, if 30 parts of sugar of fruits are analysed, and you obtain carbon 12 parts and hydrogen 2 parts, then, deducting these 14 parts from 30 parts, you have a residue of 16 parts for the weight of the oxygen. This result gives the formula CH^2O ; because $\text{C} = 12$, $\text{H}^2 = 2$, and $\text{O} = 16$; together = 30.

Before I notice the compounds which contain nitrogen, I must describe the experimental means by which the quantity of nitrogen, present in combination with carbon, hydrogen, and oxygen in an organic compound, can be accurately determined.

To ascertain whether or not an organic compound contains nitrogen, a small quantity of it is mixed with hydrate of potash, and is heated in a small glass test-tube. If nitrogen is present vapours of ammonia will be evolved, which can be detected by their odour and by their action on reddened litmus paper. See page 320. When this is found to be the case, two separate analyses of the organic compound are to be made. The first to determine the proportions of carbon and hydrogen. The second to determine the nitrogen.

The analysis for the estimation of nitrogen is founded on the test to which I have just referred. The nitrogenous compound is heated with a sufficient excess of caustic alkali to convert the whole of its nitrogen into ammonia, which is collected and weighed. What we have to consider is, how to conduct that operation so as to insure accuracy in the results.

Experience has shown that the best form in which to use the caustic alkali is in that of a compound which is called *soda-lime*. This is made by slaking some well-burnt lime of good quality with a solution of caustic soda, applied in such proportions as to yield a compound containing two parts of quicklime to one part of hydrate of soda. The mixture is evaporated to dryness, ignited, pulverised as quickly as possible, and shut up in bottles with well-fitted stoppers, to keep the mixture as free as possible from carbonic acid and moisture. Great care must be taken that the soda used for this purpose contains no nitrate of soda, and that the soda-lime contains no trace of nitrogen derived from any source whatever.

Mix the weighed quantity of the nitrogenous substance which is to be analysed in a warm mortar, with a quantity of the above-described soda-lime. Introduce the mixture into a combustion-tube, fig. 390; loosely plug up

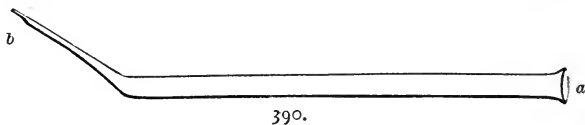

the mouth of the tube, *a*, with a few fibres of recently-ignited asbestos, and attach to the combustion-tube, by a good cork, the bulb apparatus, fig. 391, or that which is generally preferred, fig. 392. The end, *a*, of

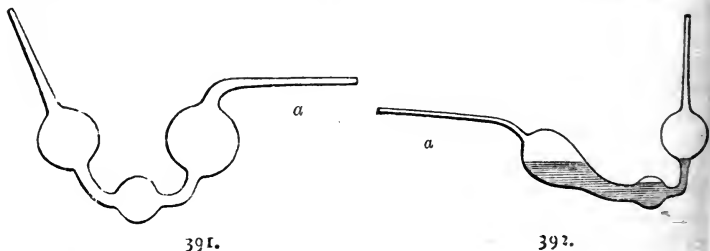

either apparatus is that which is to be connected with the mouth of the combustion-tube. The bulb apparatus is to contain a measured quantity of diluted hydrochloric or sulphuric acid of a fixed strength, determined with the greatest care by the process of centigrade testing. There must be more than enough of this acid to saturate all the ammonia which the analysed compound can possibly produce. The apparatus being thus arranged, and the combustion-tube placed in a combustion-furnace, heat is to be applied with the observance of the precautions already explained at page 373. When the gas ceases to come over, the decomposition is completed. The liquor in the bulbs then rises towards the end *a*. At this moment the point *b* of the combustion-tube is nipped off, and atmospheric air is drawn through the combustion-tube and the bulbs in the usual way. See page 373. By this means the whole of the ammonia produced by the nitrogen of the organic compound is brought into the bulb apparatus, where it neutralises part of the test-acid, but remains mixed with an excess of acid.

The liquor is now to be poured from the bulb apparatus into a beaker, fig. 393, or a wide-mouthed flask, fig. 394, and the bulbs are to be repeatedly rinsed with pure water, to bring all the contents of the bulbs into the flask or beaker. The quantity of the test-acid in excess is then to be estimated by a test-solution of caustic potash applied from a centigrade test-tube, and the number of measures of test-potash so applied is to be noted.



393.



394.

Suppose that the quantity of test-acid originally put into the bulb apparatus was sufficient to neutralise 3 grains of ammonia, and that the quantity of potash required to neutralise the excess of acid at the conclusion of the analysis was equal to 1 grain of ammonia, then the quantity of ammonia produced in the analysis was 2 grains, the nitrogen contained in which is estimated at the rate of 14 parts in 17. Of course this analysis does not convey the least information respecting the condition, or form of combination, in which the nitrogen exists in the compound that is submitted to analysis. All that we know, or guess, of the proximate constitution of nitrogenous compounds, is derived from experiments of another character—experiments in which radicals are transformed, but not destroyed.

COMPOUNDS OF CARBON AND NITROGEN.

CYANOGEN.

Formula, CN, or Cy; *Equivalent*, 26; *Specific gravity of gas*, 26; *Atomic measure when isolated*, 1 volume; *Atomic measure when acting as an acid radical in gaseous salts*, 1 volume.

I have shown, at page 380, that when an ammonium, or an amide, is decomposed by a force which abstracts all its hydrogen, the liberated nitrogen acts upon any carbon, or carbonaceous radical, that may be present, and produces a new acid radical, *Cyanogen* = CN, or Cy, which, if any basic radical is present, or is producible among the adjacent elements, forms with it a neutral salt—a *Cyanide* = M + Cy.

Advantage is taken of this principle in the manufacture of cyanides for use in the arts. The cheapest ammoniacal compounds are employed: blood, skin, horns, parings of hoofs, and other refuse animal matter, are the materials of this manufacture. 5 parts of such substances with 2 parts of carbonate of potash and iron filings, are put into a covered iron pot and ignited. The oxygen present in the mixture carries off the hydrogen as water, and some of the carbon as carbonic acid, &c., while the nitrogen, with an equivalent of carbon, forms cyanogen, and in the presence of potassium and iron produces a triple salt, which in the midst of this mixture and at the high temperature of a red heat is perfectly permanent. This salt is commonly called *Ferrocyanide of potassium*, or the *yellow prussiate of potash*, the composition of which is represented by the formula $\text{KCy} + \text{KCy} + \text{FeCy}$. When the fused mass is become cold, it is digested in water; the solution is filtered, evaporated, and crystallised, when it gives a magnificent yellow salt, containing water of crystallisation, in accordance with the formula $\text{KKFe,Cy}^3 + 1\frac{1}{2}\text{Aq}$. From this compound all the other cyanides are prepared by various chemical reactions; even salts of ammonium can be prepared from it, as I have shown at Section 4, page 357.

Preparation of Cyanogen Gas.—1. Take cyanide of mercury, dry it at a gentle heat, put it into a tube-retort, and heat it gently with a spirit-lamp. Cyanogen gas issues from the beak of the tube, and may be burned there, producing a purple flame. If you want to collect it, you must use a mercury trough, as the gas is readily soluble in water. But it is dangerous to make experiments upon this gas, as it is poisonous; and great care is required not to allow it to escape into the apartment where the experiment is made. The apparatus shown by fig. 311, page 319, may be used when the gas is to be collected over mercury.

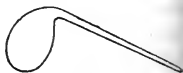

395.

2. A mixture of 6 parts of dried yellow prussiate of potash, and 9 parts of perchloride of mercury, also gives off cyanogen gas when heated.

Properties of Cyanogen.—A transparent colourless gas of very peculiar and penetrating bitter almond odour; poisonous if respired; soluble in one-fourth of its bulk of water; reddens wet litmus paper; burns in air with a beautiful purple flame; reducible by cold and pressure to the liquid state. It is one of the gases most easily liquefied. 1 volume of cyanogen gas requires 2 volumes of oxygen gas for combustion, and the products are 2 volumes of carbonic acid gas and 1 volume of nitrogen gas $CN + OO = COO + N$. It may be detonated in the eudiometer, but the explosion is rather violent and the action not quite accurate.

Liquefaction of Cyanogen Gas.—Pass the gas-delivery tube which conveys the cyanogen gas nearly to the bottom of a glass-tube receiver of the form of fig. 396, *a*, the body of which should be about $\frac{1}{2}$ an inch wide and 5 inches long. This receiver should be placed in a beaker filled with a good freezing mixture. At the temperature of -4° F. the gas condenses into a colourless limpid fluid. When enough has been collected, the gas-delivery tube must be slowly withdrawn, and then, by means of a spirit-lamp and a blowpipe, the narrow neck of the tube-receiver may be drawn out and sealed, as shown by fig. 397, without lifting the body of the receiver from the freezing mixture.



396.

Such sealed tubes containing condensed gases are sometimes liable to burst with violence if handled or warmed. That is not the case with cyanogen; but as this gas is poisonous it is not expedient to preserve such tubes, which may burst and spread the poisonous gas through an apartment on an unexpected occasion.

If potassium is heated in cyanogen gas, the gas is not decomposed, but combines with the potassium to form a cyanide $= K,CN$. It acts, therefore, like an acid radical, and it was, indeed, the first compound radical that was discriminated.

HYDROCYANIC ACID. PRUSSIC ACID.

Formula, H,CN or HCy; Equivalent, 27; Specific gravity of gas, 13.5; Atomic measure, 2 volumes.—In gaseous salts the cyanogen retains an atomic measure of 1 volume, exclusive of the measure of the basic radical with which it is combined.

Preparation of Hydrocyanic Acid.—Cyanogen and hydrogen do not combine directly, but the combination can be effected by various indirect processes. The acid can be produced in an anhydrous condition, and also in solution in water.

A. Anhydrous Hydrocyanic Acid.—Hydrocyanic acid can be prepared



397.

by distilling cyanide of mercury with concentrated hydrochloric acid. The apparatus represented by fig. 398 is employed. The materials are

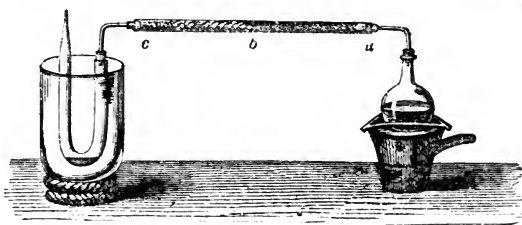

398.

put into the globular flask, and are heated over charcoal or a gas-light. The flask is put into communication with a large glass tube, *a b c*. The first half of this tube, *a* to *b*, is filled with fragments of marble, and the second half, *b* to *c*, with lumps of fused chloride of calcium. The end *c* of this tube is connected with a long U-tube, placed in a freezing mixture. Double decomposition takes place in the flask:—

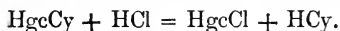

The hydrocyanic acid being volatile distils over; the fragments of marble absorb any accompanying vapours of hydrochloric acid; the chloride of calcium takes up water, and the acid becomes condensed in the U-tube in a state of dryness and purity, excepting that it can retain a small quantity of carbonic acid, expelled from the marble by the hydrochloric acid.

B. *Diluted Hydrocyanic Acid*.—1). This acid may be obtained readily by making a saturated solution of cyanide of potassium, and dropping into it as much tartaric acid as will precipitate the potassium in the state of cream of tartar. When the precipitate has subsided, the fluid may be decanted, and slowly distilled, with a moderate heat, into a receiver kept cool with water or pounded ice:—

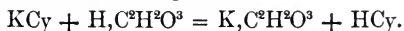

2). Crystallised formiate of ammonia is decomposed by distillation into hydrocyanic acid and water. This is an experiment which illustrates very elegantly the relation of the ammonium salts to the cyanides:—

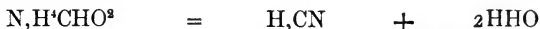

Formiate of Ammonia = Hydrocyanic Acid + Water, 2 atoms.

3). The process described in the London Pharmacopœia for the preparation of medicinal hydrocyanic acid is as follows:—Suspend 48½ grains of cyanide of silver in an ounce of water, and decompose it by 39½ grains of aqueous hydrochloric acid. Shake the mixture, and

decant the clear liquor from the chloride of silver. The reaction here is $\text{AgCy} + \text{HCl} = \text{AgCl} + \text{HCy}$. This solution contains two per cent. of the anhydrous hydrocyanic acid. If excluded from the light, the diluted acid is not so liable to spontaneous decomposition as the strong acid.

4). *Extraction of Hydrocyanic Acid from Bitter Almonds.*—If a piece of a bitter almond is put with water into the retort, *a*, fig. 399,

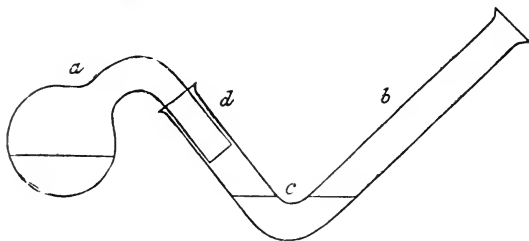

399.

and slowly distilled, the water collected at *c* in the receiver will contain hydrocyanic acid, as can be proved by applying the tests for cyanides. See page 530.

Properties of Hydrocyanic Acid.—A colourless, transparent liquid, of a strong and peculiar taste and odour, resembling those of bitter almonds. It mixes in all proportions with water. Its specific gravity is 0.7. At 5° F. it forms a crystalline mass. It is exceedingly volatile, and boils at 80° F. Though it forms a vast number of salts, its acid reaction with litmus is feeble. It readily dissolves red oxide of mercury.

Hydrocyanic acid is one of the most powerful poisons. Large animals have been killed by a few drops placed on the tongue. What is said above as to the *taste* of it applies only to extremely dilute acid. Instant death would follow the tasting of the strong acid. The preparation of this acid is accompanied by considerable danger, in consequence of its ready volatility. The odour is to many persons very agreeable, and in consequence, the extreme danger resulting from its presence is apt to be forgotten.

CYANIDES.

Synonymes, *Cyanurets*, *Prussides*, *Prussiates*, *Hydrocyanates*, &c. Formula, M,CN or MCy .

Hydrocyanic acid may be regarded as the model of the simple cyanides. It exchanges its basic hydrogen for any basic radical whatever. H,Cy becomes M,Cy , and this M may be any metal or any basic

hydrocarbon. Cyanogen combines equally well with the basylous atoms and the basylic atoms. Thus two of its principal salts are those containing Fe and Fec, producing FeCy and FecCy.

The simple cyanides combine with one another, so as to produce a multitude of complex cyanides—double, triple, quadruple, &c. In all of these varieties, it produces acid salts, that is to say, salts in which one equivalent of hydrocyanic acid is combined with one, two, or three equivalents of neutral cyanides; in some cases, all the basic radicals being alike, in others different.

Hydrocyanic acid behaves towards hydrated alcalies precisely in the same manner as hydrochloric acid. Thus, with hydrate of potash it produces cyanide of potassium and water, $\text{HCy} + \text{KHO} = \text{KCy} + \text{HHO}$. The cyanides of the alkaline metals are soluble in water. Those of the heavy metals are insoluble. But many of the double and triple salts, formed by these two classes with one another, are soluble.

Detection of Cyanides.—Most of the metallic cyanides are decomposed by hydrochloric acid, which produces metallic chlorides and free hydrocyanic acid; but there must be no excess of hydrochloric acid, otherwise the hydrocyanic acid is decomposed. A solution containing free hydrocyanic acid acts as follows:—1. It exhales the bitter almond odour.—2. With nitrate of silver, it gives a white precipitate, soluble in ammonia, but not in nitric acid, and which does not blacken when exposed to light.—3. Protonitrate of mercury gives reduced mercury.—4. Add a solution of protosulphate mixed with persulphate of iron, then render the mixture alkaline by caustic potash, so as to cause a precipitate of oxide of iron, and finally acidify the mixture by a few drops of hydrochloric acid. A precipitate of prussian blue will then appear.

EXAMPLES OF CYANIDES.

The first names are suggested according to the principles of the Radical Theory. The others are the names in common use.

A. Single Cyanides.

1. HCy	= Hydra cyana.	Hydrocyanic acid. Prussic acid.
2. KCy	= Potassa cyana.	Cyanide of potassium.
3. AgCy	= Argenta cyana.	Cyanide of silver.
4. FeCy	= Ferrous cyana.	Protocyanide of iron.
		Ferrous cyanide.
5. FecCy	= Ferric cyana.	Susquicyanide of iron.
		Ferric cyanide.
6. NH^4Cy	= Ammonia cyana.	Cyanide of ammonium.
7. CH^3Cy	= Methyla cyana.	Cyanide of methyl.

B. *Double Cyanides.*

- | | | | |
|-----|--------------------|---------------------------|---|
| 8. | HFecCy^2 | = Hydra ferric cyanen. | Hydroferricyanic acid. |
| 9. | KFecCy^2 | = Potassa ferric cyanen. | Ferricyanide of potassium. Red prussiate of potash. |
| 10. | FeFecCy^2 | = Ferrous ferric cyanen. | Turnbull's Prussian blue. |
| 11. | HAgCy^2 | = Hydra argenta cyanen. | Argentoprussic acid. |
| 12. | KAgCy^2 | = Potassa argenta cyanen. | Argentocyanide of potassium. |

C. *Triple Cyanides.*

- | | | | |
|-----|-----------------------|-----------------------------|--|
| 13. | HHFeCy^3 | = Hydren ferrous cyanine. | Hydroferrocyanic acid. |
| 14. | KKFeCy^3 | = Potassen ferrous cyanine. | Ferrocyanide of potassium. Yellow prussiate of potash. |
| 15. | FecFecFeCy^3 | = Ferrenic-ferrous cyanine. | Common prussian blue. |

The names of the triple cyanides may also be written as follows.—

- | | | |
|-----|-------------------------------|----------------------------------|
| 13. | $\text{FeCy} + 2\text{HCy}$ | Ferrous cyana bis hydra cyana. |
| 14. | $\text{FeCy} + 2\text{KCy}$ | Ferrous cyana bis potassa cyana. |
| 15. | $\text{FeCy} + 2\text{FecCy}$ | Ferrous cyana bis ferric cyana. |

The above formulæ and names differ greatly from those in common use, but I am explaining the constitution of the cyanides according to the radical theory, and not according to the numerous and complicated theories in which the facts have, up to this time, been entangled. Looking at these formulæ, there seem to be no occasion for difficulty or mystification. In group A, we have single cyanides, each containing one basic radical and one atom of cyanogen. In group B, we perceive that these simple cyanides combine together, just as the oxalates, the sulphates, and many other salts combine together to produce double salts, either acid or neutral. Thus, No. 1 = HCy combines with No. 5 = FecCy , and produces No. 8 = HFecCy^2 , or as it may also be formulated and named, $\text{HCy} + \text{FecCy} = \text{Hydra cyana cum ferric cyana}$, in which shape its relation to the two simple cyanides is perfectly evident. All the double cyanides may have formulæ and names on this plan. Again, we perceive other similar combinations of salts of the first group in pairs, forming salts of the second group, such as—

- | | |
|---|---------|
| $\text{KCy} + \text{FecCy} = \text{KFecCy}^2$, | No. 9. |
| $\text{FeCy} + \text{FecCy} = \text{FeFecCy}^2$, | No. 10. |
| $\text{HCy} + \text{AgCy} = \text{HAgCy}^2$, | No. 11. |
| $\text{KCy} + \text{AgCy} = \text{KAgCy}^2$, | No. 12. |

Proceeding to Group C, we perceive here a series of triple salts, which bear to the double salts of Group B the same relation that the

carbonates bear to the oxalates, a relation which has been fully explained at page 360. These triple salts consist in each case of three simple salts, of the form shown in Group A. Thus,

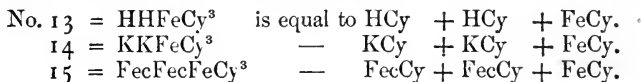

Among these salts, the following have the most characteristic properties:—No. 1. HCy = Hydrocyanic acid. No. 2. KCy = Cyanide of potassium. These are the two principal simple salts, and the model of the monobasic cyanides. No. 14 = KKFeCy^3 = Yellow prussiate of potash is the salt which is manufactured for use in the arts, and is therefore of the greatest practical importance. If the formula of this salt is compared with that of No. 15, FecFecFeCy^3 , we perceive that two atoms of potassium in No. 14 are in No. 15 replaced by two ferric atoms. In point of fact, when a solution of No. 14 is mixed with a solution of any ferric salt, the salt No. 15 precipitates in the form of a magnificent blue powder, long esteemed as Prussian blue. *Examples*:—

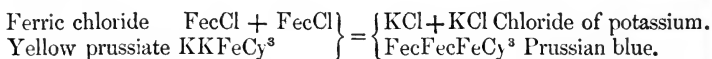

With ferric sulphate, an oxidised salt, the action is this:—

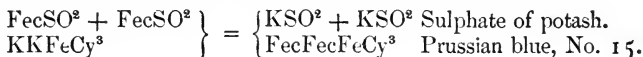

This prussian blue is therefore a triple cyanide = $\text{FecCy} + \text{FecCy} + \text{FeCy}$, in which there are two ferric atoms and one ferrous atom. We may marvel that nature provides for such curious forms of combinations, but she evidently does provide for them. Here they are, and it is needless to dispute or discredit them.

When a solution of the yellow prussiate of potash is acted on by chlorine gas, the following transformation takes place:—

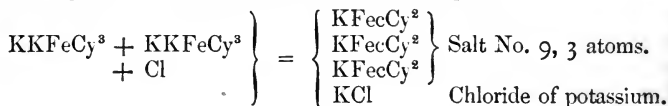

In this metamorphosis, two ferrous atoms are converted by the action of the chlorine, according to the principle which I have explained at pages 129, 155, &c., into three ferric atoms. These, with three atoms of potassium and the six atoms of cyanogen, make up three atoms of the double cyanide, No. 9, which is commonly known as the red prussiate of potash. The superfluous fourth atom of potassium combines with an atom of the chlorine to form chloride of potassium = KCl .

This red prussiate of potash also produces a kind of prussian blue, but of a different composition from the triple cyanide, No. 15. To produce the salt which corresponds with the red prussiate of potash, a solution of that salt is mixed with a solution of a ferrous salt, such as the protosulphate or the protochloride of iron, upon which the following double decompositions take place:—

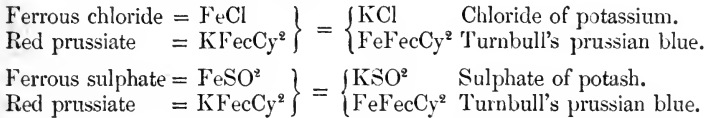

The prussian blue which is produced when ferrous salts are precipitated by red prussiate of potash, is called Turnbull's prussian blue, because Mr. Turnbull, a Glasgow manufacturer, was the first to produce this particular kind of prussian blue. It is a compound of great use in the art of dyeing.

On placing together the two kinds of prussiate of potash and the corresponding varieties of prussian blue, we perceive clearly their difference in composition and their relation to the two series of salts of iron.

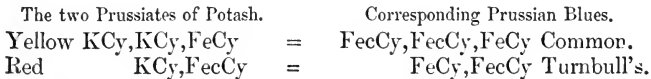

Many series of multiple cyanides, besides those which have Fe or Fec as a constant ingredient, can be prepared. Nos. 11 and 12, page 531, show the elements of a series containing silver, and other series exist which contain cobalt and chromium as constant elements. The student who wishes to have a more comprehensive account of the cyanides, is referred to my work on the Radical Theory.

Cyanates.—Salts in which cyanides are combined with one equivalent of oxygen. Thus:—

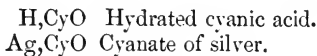

Ureas.—When the cyanates have ammonium, NH^4 , or any vice-ammoniums, for their basic radicals, they are called Ureas:—

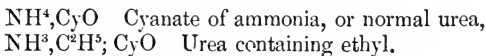

There exist a great variety of ureas of this description. See page 420.

The cyanates can be produced by passing cyanogen into a solution of caustic potash, whereupon both cyanide and cyanate are formed:—

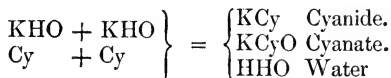

Cyanate of potash can also be procured by fusing cyanide of potassium in a crucible and adding protoxide of lead:—

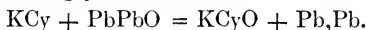

When the cyanic acid is liberated from a base by an acid, in the presence of water, it suffers immediate decomposition, producing ammonium and carbonic acid:—

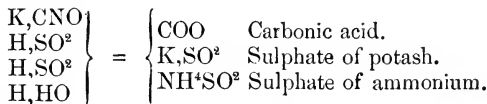

COMPOUNDS OF CARBON, HYDROGEN, AND NITROGEN.

The Condition, or Forms of Combination, in which Nitrogen is found in Organic Compounds.

In the preceding pages I have endeavoured to explain by what synthetic processes the innumerable and diversified compounds of organic life are built up from the four elements, which are their chief constituents. In so far as regards the three elements, carbon, hydrogen, and oxygen, the facts and theories respecting them have been stated fully, but I have only given incidental notices of the compounds which contain nitrogen as an unfailing and characteristic ingredient. When this element acts evidently as an acid radical, or as a constituent of an amidogen or an ammonium, of a cyanide, or a cyanate, it falls within the compounds which I have described. But it often occurs in combinations, the proximate constitution of which is doubtful and unknown, and unfortunately this is especially the case with compounds of the utmost importance in the animal body and among the materials of our food and medicines. While the power of the chemist continues to be thus limited, while it is impossible for him to separate from one another, experimentally or mentally, the proximate ingredients of such compounds, he will remain unable to trace the causes of their metamorphoses, to point out how and why our food sustains us and our medicines alleviate our sufferings, how plants are nourished, and what is the mode of operation of the power which causes those chemical changes to be effected by which carbonic acid and water are converted into sugar, and by which sugar is converted into starch and wood, or into the acids, the fats, the essential oils, and the innumerable salts composed of radicals, amidogens, and ammoniums, which no doubt form the proximate constituents of living plants and animals.

Take into consideration a few examples, which render manifest the present state of the ignorance of chemists in this department. I find

the following formulæ of important animal compounds in a recent work of great eminence :—

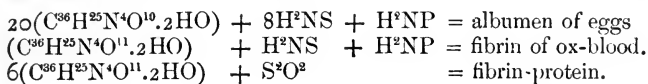

These formulæ are the result of calculations after careful analytical experiments. To me they are incomprehensible. Like figures reckoned to billions and trillions, and quadrillions, they go beyond my powers of perception. But just as far as they are comprehensible, they are incredible. Between such formulæ and those which have hitherto occupied our attention, there seems to be an impassable gulf. Instead of seeing radicals and salts arranged in intelligible order, we look here upon a thick mist, in which, and through which, no object is discerned distinctly. This, indeed, is not the case with all the nitrogenous compounds of the animal and vegetable kingdoms. So deep a darkness does not extend over all the objects of our contemplation in those regions. But there is unfortunately quite enough of it to make the study of such organic compounds one of considerable difficulty. Let us hope that some power of analysis will speedily be discovered which will help us to reduce these gigantic formulæ into such as will harmonise in simplicity and clearness and utility with those which the Radical Theory provides for compounds of the hydrocarbons.

Aniline.—A glance at the compounds of aniline will give the reader some idea of the remarkable variations in the mode of action of the element nitrogen. I select the following formulæ from amongst one hundred that are collected in my treatise on the Radical Theory, where this subject is discussed fully :—

1. $\text{NH}, \text{C}^6\text{H}^5$; H. This is aniline, the hydride of a vice-amidogen; or an ammonia, in which H^1 has been replaced by phenyl = C^6H^5 .

2. $\text{NH}^3, \text{C}^6\text{H}^5$; Cl. In this case the vice ammonia, or hydride of a vice-amidogen, is converted, by combination with hydrochloric acid, into the chloride of a vice-ammonium.

3. $\text{NH}^3, \text{C}^6\text{H}^5$; NO^3 . This is a nitrate of the same vice-ammonium. Here nitrogen acts in two conditions, as it does in common nitrate of ammonia, namely, *basic* in the state of hydride, *acid* in the state of oxide.

4. $\text{NH}^3, \text{C}^6\text{O}^5$; CO^2 . The corresponding oxalate of the vice ammonium.

5. $\text{NH}, \text{C}^6\text{H}^5$; CO. The amidogen salt derived from No. 4, and corresponding to oxamid. See page 378.

6. $\text{NH}, \text{C}^6\text{H}^5$; $\text{CO} + \text{HCO}^2$. This is the amided acid which corresponds with oxamic acid, page 379.

7. $\text{NH}, \text{C}^6\text{H}^5$; NO^2 . The amidogen salt which corresponds to the ammonium nitrate, No. 3. Nitrogen is here acting in two conditions.

8. $\text{NH}, \text{C}^6\text{H}^5$; Cy. The cyanide of the vice-amidogen. Here again nitrogen exists in two conditions.

9. $\text{NH}_3\text{C}^6\text{H}^5$; $\text{Cy} + \text{NH}_3\text{C}^6\text{H}^5$; Cl . A compound of No. 8 with No. 2. In this compound, nitrogen exists in three conditions—in amidogen, in ammonium, and in cyanogen.

10. $\text{NH}_3\text{C}^6\text{H}^5$; $\text{NO}^2 + \text{HCyO}$. A compound of the amidogen salt No. 7, with hydrated cyanic acid. The nitrogen is here in three different conditions—in amidogen, as an acid radical in NO^2 , and as an ingredient in the cyanogen of the cyanic acid.

11. $\text{NH}_3\text{C}^6\text{H}^5$; $\text{Cy} + \text{NH}_3\text{C}^6\text{H}^5$; NO^3 . A compound of No. 8 with No. 3. In this double salt, the nitrogen exists in no less than four different conditions—in amidogen, in ammonium, in cyanogen, and in nitric acid.

These few examples serve to show the immense difference between the ultimate and the proximate analysis of a compound. If we take the last example, and throw the elements into the form of a unitary or clump formula, as given by an ultimate analysis, we have $\text{C}^{13}\text{H}^{14}\text{N}^4\text{O}^3$. By transposing these elements, we might produce a very great variety of formulæ for the compound No. 11 without hitting upon the true one. It is not by the arbitrary and fanciful arrangement of letters and figures that true formulæ are produced. It is from the study of the nature and properties of compounds, of the methods of producing them, and of the results of their decomposition, under the various circumstances which chemists have agreed to fix upon as standards of comparison, that information is gained which leads to an accurate knowledge of the proximate constitution of chemical compounds, and which points out the formulæ by which the accurate knowledge so acquired is expressed and recorded.

Organic Bases.—Owing, however, to the diversity of conditions in which nitrogen occurs in organic compounds, it is frequently impossible, even after the most patient and careful examination of all the ascertainable properties of nitrogenous compounds, to fix their formulæ unexceptionably. This, for example, is the case with the substances that commonly bear the names of *Alkaloids*, or *Organic Bases*. These are compounds of great importance as medicines, as ingredients in articles used for food or beverages, and as virulent poisons, against which it is necessary to take suitable precautions. The ultimate constitution of these compounds is known, but their proximate constitution remains doubtful and uncertain.

Names and Formulæ of several Alkaloids.

$\text{C}^{20}\text{H}^{24}\text{N}^2\text{O}^2 + 3\text{Aq}$. *Quinine*. From Peruvian bark.

$\text{C}^{20}\text{H}^{24}\text{N}^2\text{O}^2 + \text{HSO}^2 + 3\frac{1}{2}\text{Aq}$. Its disulphate.

$\text{C}^{20}\text{H}^{24}\text{N}^2\text{O}^1 + 2\text{HSO}^2 + 7\text{Aq}$. Its acid sulphate.

$\text{C}^{17}\text{H}^{19}\text{NO}^3 + \text{Aq}$. *Morphia*. From opium.

$\text{C}^{17}\text{H}^{19}\text{NO}^1 + \text{HCl} + 3\text{Aq}$. Its hydrochlorate.

$\text{C}^{17}\text{H}^{19}\text{NO}^3 + \text{HSO}^2 + 2\frac{1}{2}\text{Aq}$. Its sulphate.

$C^{21}H^{22}N^2O^2$. *Strychnine*. From *nux vomica*.

$C^{21}H^{22}N^2O^2 + HSO^2 + 3\frac{1}{2}Aq$. Its sulphate.

$C^9H^{10}N^4O^2 + Aq$. *Theine* and *Caffeine*. From tea and coffee.

C^5H^7N . *Nicotine*. From tobacco.

$C^8H^{15}N$. *Conia*. From hemlock.

The preparation and purification of these compounds demand considerable skill, experience, and expenditure of money. They form only a small percentage of the substances from which they are extracted, and they are combined or mixed in those substances with many other organic compounds, from which, in some cases, they can only be separated by complicated processes, involving the use of large quantities of pure ether, alcohol, and other expensive reagents. The details can be found in any large work on Organic Chemistry.

A peculiarity will be noticed in the manner of combination of the alkaloids with the hydrated acids. The combination is effected without separation of hydrogen or oxygen. A hydrated alkaloid combines with a hydrated acid. There is no separation of water, such as occurs when caustic potash, or any other hydrated basic radical, combines with hydrochloric acid or hydrated sulphuric acid:—

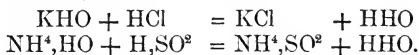

The inference which this peculiarity forces upon us is, that the alkaloids are complete salts, which combine, as such, with hydrated acids, to form double salts, and not to form simple salts, in which the alkaloids act as basic radicals. Yet this observation does not enable us to discover in what form of combination nitrogen exists in these remarkable compounds; nor does it even enable us to determine the true equivalents of the alkaloids. Thus, quinine may either be $C^{20}H^{21}N^2O^2$, or $C^{10}H^{12}NO$; and Theine may be either $C^8H^{11}N^4O^2$, or $C^4H^5N^2O$.

In consequence of the difficulties which attend the investigation of nitrogenous compounds, and of the small space which this volume can afford for a subject which cannot possibly be brought within the range of elementary and popular explanation, I shall close this section with a few brief notices of those animal compounds which derive importance from their relation to the important subjects of food, digestion, and respiration, referring the reader who wishes for greater details to the larger works on Organic Chemistry, written by Gregory, Miller, Gmelin, Gerhardt, and other chemists of the present era.

FOOD, DIGESTION, AND RESPIRATION.

EXAMINATION OF AN EGG.—In this case we have to consider the white, the yolk, and the shell.

White of Egg. Albumen.—The white of an egg consists of cells,

which contain a transparent colourless liquid, having an alkaline reaction. Of this liquid seven parts in eight consist of water, and one in eight of solid albumen. When heated, this mixture coagulates. When beaten with rods, it forms a thick foam. The properties of this animal albumen resemble those of vegetable albumen, already described at page 499. Its extremely complex constitution I have referred to at page 535. The following formulæ are given by other chemists. They serve to show approximately what is the ultimate constitution, but prove that, of the proximate constitution, chemists know nothing:—

a). $C^{108}N^{36}S^3H^{169}O^{34}$, besides phosphates.

b). $NaHO, C^{72}H^{110}N^{18}S^2O^{21}$, Aq.

Use of Albumen as a means of Clarifying Turbid Liquors.—Coffee, syrups, and other turbid liquors can be rendered clear by means of albumen. Make a syrup with warm water and honey, add to it a little liquid white of egg, and boil the mixture. When the albumen coagulates, it takes with it the solid particles which swim in the liquor, and a subsequent filtration renders the liquor perfectly clear.

Yolk of Egg.—It contains water and albumen, a little casein, and a considerable quantity of fat or oils, consisting of margarin and olein, with an oil which contains phosphorus. The oils can be squeezed out from a hard-boiled egg, or be extracted by ether, in which they dissolve.

Both the white and the yolk of egg contain earthy salts. When they are burnt they leave these as ash. The white of egg leaves chloride of sodium, carbonate, phosphate and sulphate of soda and of potash, and phosphate of lime and magnesia. The yolk yields the above, and in addition a little iron. The chief mineral ingredients are the potash salts and earthy phosphates.

Egg-shell.—Fit up the apparatus, fig. 400. Put some egg-shell into the gas-bottle, and lime-water into the wash-bottle. Add hydrochloric acid by the funnel. Carbonic acid gas will be disengaged, which will give a precipitate of carbonate of lime in the wash-bottle. The egg-shell will all dissolve except a gelatinous skin. The solution in the gas-bottle will be found to contain chloride of calcium, mixed with a quantity of phosphate of lime. The lime and the phosphoric acid may both be detected by applying the appropriate tests. These experiments show that egg-shell consists of carbonate of lime, a little phosphate of lime, and some gelatinous membrane.



400.

MILK.—Milk consists of water, holding casein and milk-sugar in

solution, and butter in a state of admixture. The latter appears to be in small balls, enclosed in membranes. These give a partial opacity to milk. If milk is mixed with a little dilute acetic acid, this membrane of the butter balls becomes visible under the microscope.

Cream.—When fresh milk is allowed to stand undisturbed for a few hours, the fatty matters rise to the surface, and form a layer which is called cream. As this is an important part of the milk, its measure is frequently taken as an estimate of the quality of the milk. The test is made by means of a graduated instrument called a *Lactometer*, fig. 401. This has a scale of 100 parts. The milk is poured in up to 0, the instrument is closed with a glass stopper, and set aside in a cool place for 24 hours. In warm weather it should be placed in a vessel of cold water. When the cream has settled at the top of the milk, the quantity can be read off on the engraved scale. It usually amounts to 4 or 5 parts in 100. The contents of the instrument should not be less than 100 septems. In important experiments, to find the relative value of different cows, or of different systems of feeding, it is better to use larger quantities of milk, such as the tenth part of a gallon, in which case the vessel, represented by fig. 79, page 101, may be employed as a lactometer. The object of closing the vessel and of putting it into cold water is, to cut off atmospheric influences, which much interfere with this trial in hot stormy weather. The cream rises most readily when the milk is diluted and well mixed with an equal bulk of water.

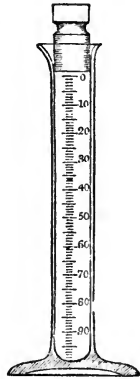

401.

Butter.—The separation of cream from milk is an imperfect aggregation of the butter. In the separation of butter, in the large way, the cream is churned, or beaten up mechanically, by which process the membranes of the butter-balls are broken, and the butter is enabled to agglomerate into masses. The liquid which remains is called buttermilk. The agglomerated fats are afterwards washed and pressed. The product is butter. By these processes casein and albumen are separated. The more completely this separation is effected, the more careful the washing and the more compact the pressing, the longer will the butter keep free from rancidity, because the caseous matter acts as a ferment, and is the cause of decomposition among the fats. The reason that salt retards the decomposition of butter is that it hinders the formation of those volatile fatty acids which possess a rancid odour. Butter consists, in the main, of margarin (page 460), olein (page 429), and butyryn (page 452); but it also contains small and variable quantities of caproine, capryline, and caprine. It is to these volatile oils that the flavour of milk and butter is owing. When these glycerides are decomposed by the joint action of air and moisture, various volatile stinking

fatty acids are produced, the presence of which constitutes rancidity. When butter, thus become rank, is boiled with repeated quantities of water, the stinking acids dissolve and are removed, and the residue of the butter is rendered less rank.

Casein.—Milk, after separation from the butter, is to be mixed with a few drops of acetic or hydrochloric acid; upon which a white flocky mass is precipitated. This is casein. It agrees in composition and properties very nearly with vegetable casein, described at page 500. The formula given to casein by Liebig is $C^{144}N^{36}S^2H^{228}O^{45}$, with some phosphates. Casein is soluble in diluted alcalies, and also in an excess of acid. It is insoluble in water, but is dissolved in milk, in consequence of the presence there of a free alcali. When this alcali is neutralised by the addition of an acid, the casein precipitates.

Albumen.—The milk from which butter and casein have been separated is to be filtered and boiled. If any muddiness occurs, it is produced by albumen. The quantity is extremely variable. Immediately after the birth of the young animal, the milk of the mother contains a considerable quantity of albumen; but milk in its normal condition contains scarcely any of that compound.

Curds and Whey. Cheese.—Take a small piece of dried and salted calf's stomach (*rennet*); soak it in a spoonful of water; mix this water with a basinful of fresh milk, and place the mixture in a warm situation for some hours. The milk then appears as a gelatinous mass. If this is broken up we find a solid curd and liquid, commonly known as curds and whey. The curds consist of casein in mixture with the butter of the milk; and if separated from the whey, consolidated by pressure, and dried, it forms *sweet-milk cheese*. When cheese is newly made it has but little flavour. As it grows old, oxygen acts on its fats and nitrogenous substances, producing ammonia, butyric acid, valeric acid, and other volatile compounds, which collectively give to old cheese its pungency. If sweet herbs are incorporated with cheese, their essential oils necessarily affect its taste and odour.

Whey. Milk Sugar.—The clear yellow liquid, separated from the casein or curd, is called *whey*. It consists in the main of a solution of milk sugar, which may be separated by the process described at page 498.

Lactic Acid. Acid of Milk.—If a solution of milk sugar is mixed with rennet and digested in a warm place, it is gradually converted into lactic acid. See page 450.

Curdling of Milk by Acids.—The formation of curds, which rennet produces after a reaction of many hours' duration, is effected instantly by the action of a few drops of any strong acid. The curds in this case also contain all the casein and butter of the milk thus acted on.

Spontaneous Curdling of Milk.—When milk is exposed to the air in flat open vessels, the sugar of milk gradually produces lactic acid, which,

like all other hydrated acids, curdles the casein. The milk becomes most readily sour to the taste, when the weather is hot and the milk is agitated by transport. In a cool quiet place the milk becomes acid only after the cream has risen. It is from this cream that butter is commonly prepared, and consequently the whey which separates from it—the *butter-milk*—is sour. It consists of casein, lactic acid, and water, with a little butter. From this *butter-milk* it is possible to make a very poor description of cheese, the poet's

— “Three times skimmed cream cheese.”

Fermentation of Milk.—Milk that has been curdled by spontaneous acidification is to be exposed to fermentation at a temperature of 75° to 85° F. The apparatus described at page 343, fig. 337, is to be used. A lively disengagement of carbonic acid gas takes place. The milk sugar which had escaped conversion into lactic acid is at the higher temperature, and in the presence of casein, which acts as a ferment, converted into carbonic acid gas and alcohol. If the fermented liquor is afterwards subjected to distillation, the alcohol which passes over is accompanied by butyric acid, and other volatile acids of the fatty series, which give the resulting brandy a certain flavour. In this manner the Tartars prepare a beverage from the milk of mares.

Ashes of Milk.—The ashes produced by evaporating and calcining milk consist of potash, soda, lime, magnesia, oxide of iron, phosphoric acid, sulphuric acid, and chlorine.

Composition of the Milk of Woman and of various Animals.

	Woman.	Cow.	Goat.	Ass.	Sheep.	Bitch.
Water . . .	88.6	87.4	82.	90.5	85.6	66.3
Butter . . .	2.6	4.	4.5	1.4	4.5	14.8
Sugar and soluble salts . . . }	4.9	5.	4.5	6.4	4.2	2.9
Casein and insoluble salts . . . }	3.9	3.6	9.	1.7	5.7	16.
Sp. grav. variable	1.03 1.034	1.03 1.035	1.036	1.023 1.035	1.035 1.041	1.033 1.036

CONSTITUTION OF EGGS AND MILK.

“Everybody may eat eggs and drink milk. Food of that *simple* character can harm nobody.” So says the popular voice, and so far as regards the utility of these articles of food the popular voice is right. But when we come to criticise this character of ‘simplicity,’ in a

chemical sense, we are forced to declare, that milk and eggs contain some of the most complex and most incomprehensible of the many compounds which creation offers for our examination. We have a guess, and only a guess, at the ultimate constitution of casein and albumen, while of their proximate constitution we are in a state of total ignorance.

Milk and eggs contain these ultimate elements :—

Carbon, hydrogen, nitrogen, oxygen.

Sulphur, phosphorus, chlorine.

Potassium, sodium, calcium, magnesium, iron.

These are the elements which compose eggs and milk. These same elements compose the principal articles of vegetable food. The same elements compose the bodies of animals. The same elements compose human beings. We eat and drink compounds of these elements. They run through our veins and arteries. They constitute our veins and arteries. They produce our muscles, our bones, our nerves. They are the materials of our blood, our brain, and the organs of our senses. How different is the living human body from these several elements, laid bare and isolate by the craft of the chemist! It is well for man to contemplate the relation of his body to the elements of which it is composed. These elements form the dust from which he came, and will form the dust to which he must return. Of atoms of these twelve elements is he built up, and as salts and gases of these twelve elements will he shortly be scattered before the winds of heaven. Apart from the intellectual and eternal spirit which guides him, apart from the natural life which directs and controls the chemical workings of the material elements, what is man? A congeries of SALTS OF ORGANIC AND INORGANIC RADICALS. So much the more wonderful is the wisdom and power of the Omnipotent, who directs and controls the working of the universal world.

Essential Ingredients of Food.—When eggs and milk are eaten, the food has the greatest possible similarity to the constitution of the human body. The organs of digestion have, so to speak, merely the task of taking up for circulation in the blood materials fully prepared for that purpose. But when the twelve elements, which are the ultimate constituents of eggs and milk, are to be sought for among vegetable substances, there is a lower degree of preparation to be expected, and it becomes necessary to consider the available kinds of food under some general point of view. We may class them as follow :—

a). *Non-nitrogenous Materials.*—These comprehend the fats and oils, the starches, gums, and sugars, and such kinds of cellulose as are eatable and digestible. These articles may be compared to the *Fat of Animals*.

b). *Nitrogenous Substances.*—These include vegetable albumen, vegetable casein, and gluten, or vegetable fibrin. These three substances agree in constitution with the *Blood and Flesh of Animals*.

c). *Vegetables which contain Mineral Substances.*—These must include all such as are necessary for the construction of special organs, above all the materials for the *Bones of Animals*.

A variety of chemical and physiological considerations, which cannot be here detailed, prove that the substances of Group a) are required for the production of animal fat, and for the support of respiration, and the consequent development of that animal heat which is necessary to the continuance of life; and that the substances of Groups b) and c) are required for the production of those indispensable portions of the animal system—blood, flesh, and bones.

A. *Heat-givers, Fat-formers, Supporters of Respiration.*—As long as an animal lives, its blood is in continual circulation. From the heart, red blood flows without ceasing through the arteries to all parts of the frame of the body, and thence returns to the heart, through the veins, darkened in colour and changed in composition. Before it renews its course, it passes into the lungs, and comes freely into contact with atmospheric air, inspired by the mouth. A wonderful change then takes place. The dark-coloured blood of the veins is changed into the red-coloured blood of the arteries, while, simultaneously, part of the oxygen of the air disappears, and its place is supplied by carbonic acid gas and water; for the expired air is found by experiment to have undergone this change. Now, the conversion of oxygen into carbonic acid and water, is equivalent to the burning of carbon and hydrogen in oxygen, and that burning, whether rapidly or slowly effected, produces a certain amount of heat, which, in the circumstances that I am describing, must be called animal heat. No nitrogen is concerned in this operation. That element is necessarily excluded, for if it combined in the lungs with carbon it would produce cyanogen; if with hydrogen, it would produce ammonia; either of which compounds produced in the lungs would extinguish life immediately. The chemical action which is concerned in respiration is consequently the combustion of hydrocarbons; and the form in which the hydrocarbons make their way into the lungs, is some sort of compound derived from starch, or sugar, or other vinylates, all of them multiples of CH^2O —or from fats which are essentially multiples of CH^2 with very little oxygen—which compound is gathered up by the blood in its passage through the body and brought into the lungs for combustion in the inspired oxygen. That this combustion does not go on at too rapid a pace is provided for by the presence of a mass of uncombined and uncombinable nitrogen, whose presence keeps the action of the oxygen within wholesome bounds. When an animal eats a surplus of saccharine matters, they accumulate in the body, and the animal becomes fat. When an animal eats too little of such matters, the respiratory organs are supplied with carbon at the expense of the accumulated fat of the body, and the animal becomes thin. He gradually burns away.

B. *Flesh-formers*.—Clearly distinguished from the foregoing are those descriptions of food, which serve, not simply to give heat by supporting respiration, but to produce blood, muscle, and all those parts of the body which contain nitrogen. These are the nitrogenous compounds. The animal and vegetable albumen, casein, and fibrin, and the compounds that contain bone-earth, common salt, and the other mineral ingredients of flesh and bones. Among the parts of plants it is chiefly the seeds which contain these ingredients, though in some cases the young stalks and leaves of plants include them. They must, when eaten, be in a digestible state, that is to say, in a state capable of solution in the stomach. The dissolved substance mixes with the blood and circulates through the system, and as the power of life directs, produces here flesh or bones, there nerves and veins, and over all skin, hair, feathers, or shells, as the necessities of the animal demand.

Both these varieties of food are equally necessary for the support of the animal. Without the latter, there could be no blood, no flesh, no bones; without the former, no respiration, no heat, no life.¹

¹ In reference to the constitution of articles of food, I take the liberty to refer the teacher to a pair of diagrams illustrating this subject, which have been designed by Professor Lyon Playfair, and are published by the publisher of this volume:—

1. *Diagrams showing the Chief Ingredients in Varieties of Food*.—The size of this diagram is 78 inches by 35 inches. It is coloured in such a manner as to show distinctly the *percentage* in each kind of food of those ingredients which deserve the respective names of flesh-formers, of heat-givers, of carbon contained in the flesh-formers, of carbon contained in the heat-givers, and of the mineral matters, or ashes, of the food. The varieties of food of which the constitution is thus detailed are the following:—Cheese, dry peas, cooked meat, oatmeal, barley-meal, fish, wheat flour, Indian meal, cocoa-nibs, bacon, bread, green peas, rice, milk; sago, tapioca, and arrow-root; cabbage, parsnips, potatoes, turnips, carrots, beer, sugar; suet, fat, and butter. At a glance, therefore, this diagram shows the comparative value of these kinds of food, both as materials to promote respiration and to produce flesh.

2. *Diagram containing Eleven Examples of National Dietsaries*, showing the chief ingredients of the food, expressed in ounces per week. The size of this diagram is 26 inches by 35 inches. It is so coloured as to discriminate the same ingredients of food as are discriminated in the first diagram, excepting the mineral matter. It shows, therefore, the flesh-formers, the heat-givers, and the proportions of carbon contained in each of them. The dietsaries included in this table are as follow:—English soldier, French soldier, Dutch soldier, English sailor, Greenwich pensioner, Chelsea pensioner, English prison dietary (three months' hard labour), pauper dietary (average of English Unions), Christ's Hospital School, Greenwich School, Arctic travellers in Fort Confidence.

As examples of the information given in this diagram, I may quote the figures which are intimated by the colours of two of the dietsaries:—

	Blue-Coat School.	Arctic Travellers.
Flesh-formers	17	148
Carbon in ditto	9	80
Heat-givers	61	110
Carbon in ditto	30	70

The reader is referred for a further account of these diagrams to an *Essay on Food* by Dr. PLAYFAIR, contained in HUGHES'S "Reading Lessons," Second Book.

Digestion.—While food is being masticated, it is mixed in the mouth with saliva, which not only moistens and lubricates it, and so facilitates the act of swallowing, but communicates to the food a compound called ptyalin, which is produced in the mouth, and which has the power of converting starch into dextrin and sugar, and of thus facilitating its solution in the stomach. In this mode of operation, ptyalin acts like diastase. See page 505. When food is not sufficiently masticated, the proper proportion of ptyalin is not communicated to it, and digestion of that food in the stomach becomes difficult.

In the stomach, the food is acted upon by a mixture consisting of the gastric juice, lactic acid, hydrochloric acid, and pepsin, which is an albuminous body, forming one of the constituents of the gastric juice. After remaining in the stomach for a few hours, the food assumes a pasty form, in which the fibrin and albumen of the food exist in the liquid state, while the starchy matters are only imperfectly rendered soluble, and the fatty matters are unaffected. This mass is termed *chyme*. From the stomach, this mass passes into the intestinal canal, in its passage through which it is mixed with bile and other secretions, and undergoes further changes. In the small intestines, it is divided into two portions, the smaller of these, consisting of woody fibre and other insoluble and indigestible matters, becomes excrementitious, and is finally rejected. The larger portion forms a thin milky fluid called *chyle*, which is ultimately passed into the blood. From the blood, purified by the act of respiration, all the components of the body are produced, just as in the living plant, the solution of sugar is the source of all the compounds which contribute to its growth and completion.

The different organs of the body are continually undergoing waste and renovation. When active exercise is taken, the respiration is more vigorous than when the individual is in a state of repose. More oxygen enters the lungs, more carbon and hydrogen is consumed, a greater waste of organic tissues ensues, and more food must be eaten and digested to supply this waste. In cold climates, also, more food must be consumed, especially more saccharine and fatty food, to supply the means for that vigorous combustion in the lungs which is necessary to keep up the requisite amount of animal heat. As new organic tissues are produced, the materials of the effete tissues are carried off as excrements by the intestines or by the bladder. The kidneys secrete urine from the arterial blood, and in that fluid is found the waste nitrogenous elements of the food and of the used-up compounds of the animal frame. For the most part, nitrogen occurs in urine in the state of urea, accompanied by a constant but small quantity of uric acid, in combination with some metallic base. The presence of these nitrogenous compounds in urine, renders that liquid of great utility as a manure. Exposed to the air, urea rapidly undergoes putrefaction, and

produces carbonate of ammonia, an important material for promoting the growth of plants.

Blood.—Blood is a mixture of many compounds, always moving, always on the change, and of which it is consequently impossible to give an exact account, without giving a long account, for which I have no space. It contains 70 per cent. of water. Its chief constituents are albumen, fibrin, globulin, and hæmatin. The albumen of blood nearly resembles that of the egg. Its fibrin resembles the fibrin of the pea (page 500). Its globulin is an albuminous compound. The hæmatin is a colouring substance, to which the redness of the blood is owing, and which contains as an ingredient a remarkably large proportion of iron. Such are the chief components of blood, a detailed account of which must explain its relation to all the following compounds which occur in it, namely, albumen, fibrin, hæmatin, globulin; oleic, stearic, lactic, phosphoric, sulphuric, and hydrochloric acids, in combination with soda, potash, ammonia, lime, and magnesia; minute portions of cholesterin, a small quantity of phosphorised fat, containing phosphoglyceric acid; and oxygen, nitrogen, and carbonic acid gases in solution in the fluids.

Muscular Tissue. Flesh. The Lean of Meat.—This consists of animal fibrin, in the form of bundles of fine fibres, the interstices of which contain three-fourths of its weight of water, including blood and various substances secreted from blood. It is intermixed with cellular tissue, nerves, veins, and fatty matter.

Extraction of the Soluble Constituents of Flesh.—Chop four ounces of lean beef into fragments, digest it in a beaker-glass with four ounces of cold water. After fifteen minutes, press the liquor through a linen cloth. Repeat the operation with other four ounces of water, and again a third time. The resulting red liquor contains nearly all the soluble constituents of the beef, including those which give flavour to meat. If the solution is heated to 140° F., a frothy mass separates, which is albumen. If the liquor is filtered from the albumen, and boiled, turbidity is again produced by the hæmatin and fibrin of the blood. The liquor which then remains clear (the *bouillon*) contains phosphoric acid, butyric acid, and lactic acid, in combination with potash, soda, and magnesia, and some little-known compounds called kreatine, inosite, and kreatinine. If the liquor is further evaporated, it becomes first yellow, then brown; and if driven carefully to dryness, it forms a soft, dark-brown mass, of which half an ounce with a pound of water, and a little salt, produces beef soup, or *beef tea*, of good flavour.

Fibrin.—If the meat, washed as above-described with cold water, is afterwards boiled in water for some hours, a solution is obtained which on cooling produces a cake of fat or tallow, and a jelly, which is a solution of gelatine, or glue. The substance which remains undissolved in the hot liquor, and which may be taken out from it and washed, is

fibrin, a milk-white, hard, tasteless, odourless, fibrous mass, resembling in composition blood-fibrin, or albumen. In this condition, fibrin is very difficult of digestion, and has lost its nourishing power.

Quantitative Composition of Beef.

100 pounds of beef contain as follows:—

a).	Soluble in cold water.	About one-half of it albumen .	6 lbs.
b).	Yielded to five hours boiling in water,	<i>chiefly gelatin</i> .	$\frac{1}{2}$
c).	Fibrin, without taste or juice		16 $\frac{1}{2}$
d).	Fat.		2
e).	Water		75

Chemical Changes effected on Meat by Cooking it.

Roasting.—When meat is roasted before a fire, the albumen is gradually coagulated from the surface towards the interior. The outside becomes brown, and is partially changed in composition, but the sapid and saline constituents of the juices contained in the meat are retained by the coagulated albumen on the surface. Only a little runs down with the fat and collects below, as *dripping*. The meat should at first be placed near a good fire, in order that the outside may be rapidly coagulated. It should then be removed farther from the fire, to let the roasting proceed gradually. If the roasting is not continued long enough, so that the albumen near the middle is not coagulated, and the flesh continues red and juicy, it is said to be *underdone*. The advantage offered by roasting over boiling is that the important soluble ingredients of the meat are not dissolved in water, and washed away into the soup—or the common sewer.

Boiling.—The boiling of meat may be performed with two different objects:—To render the meat the most valuable. 2. To render the soup the most valuable.

1. *Boiling for the sake of the Meat.*—To preserve the full flavour of the meat, and to fit it for digestion, the water should be made to boil, and the meat be inserted into the boiling water. Then the heat should be reduced till it simmers gently, and this heat should be prolonged until every part of the meat has attained a temperature of 170° or 180° F. By this treatment, the albumen on the outside of the meat is in the first place coagulated by the boiling water, so as to make a coating impervious to the valuable juices in the body of the joint, which are thereby confined within it, to enrich the boiled meat. In this case, the soup is worthless.

2. *Boiling for the sake of the Soup.*—To make good soup, the flesh is put into cold water and the heat is raised very slowly. The soluble albumen, the soluble salts, and the flavouring portions of the meat, all of which are soluble, because whatever is insoluble has no taste, pass gradually into the water. The meat becomes impoverished, hard,

ragged, fibrous, and tasteless. The soup gains what the meat loses, not only in flavour, but in nutritious qualities. When the water boils, the heat gradually penetrates into the joint, and the cooking is finished when the albumen is coagulated at its centre. Of course the process is hastened, the soup rendered better and the meat worse, by cutting the meat into fragments, before putting it into the water. The best soup is made by a prolonged digestion of the meat at a very low temperature, which extracts from the meat all that is soluble and nutritious. This prolonged digestion of meat constitutes what is commonly termed *stewing*. When ignorant cooks prepare stews by *boiling* the meat, they destroy the food, and damage equally their employer's stomach and pocket.

Beef Tea.—Raw, lean beef, is to be finely minced, mixed with an equal weight of cold water, and very slowly heated till the mixture boils. One minute suffices to coagulate the albumen. The liquid is then to be strained through a linen cloth and pressed from the meat. The solution is to be seasoned with salt and spices as desired, and warmed for use. It is nutritious and has a good taste, but little colour. By means of burnt sugar or French onions, a brown colour can be given, if it is necessary to gratify the eye as well as the palate.

SKIN, GELATIN, AND GLUE.

If skin is put into cold water, it swells but does not dissolve, and after some time it undergoes putrefaction. If it is boiled in water for some hours, the greater part of it dissolves, and the solution, on cooling, produces a *jelly*. When this jelly is dried to a solid, it forms *glue*. This substance does not exist ready-formed in skin, but the cellulose tissue is destroyed by the boiling water, and the product is *gelatin*. This compound is an important ingredient of animal bodies, occurring almost as abundantly as albumen, and having very nearly the same composition, but with rather less carbon and more nitrogen. It is remarkable as occurring in animals only, and not in vegetables. Its composition is about, carbon 50, hydrogen 7, nitrogen 17, oxygen and sulphur 26. Isinglass, glue, and size, are varieties of gelatin differing in purity. The sinews, cartilages, bones, and interior skins of flesh, produce gelatin as well as the outer skin, which is the reason that many kinds of soups gelatinise on cooling. But it is a mistake to imagine that the nutritious qualities of a soup depend upon the hardness of its jelly when cold.

Gelatin has neither taste nor odour. It softens and swells in cold water, but does not dissolve unless the water is warmed. It is insoluble in alcohol and ether.

The Jellies of the Confectioner consist of solutions of the purer kind of gelatin, flavoured with sugar, wine, lemons, and spices.

Glue is prepared from the refuse trimmings of ox-hides, &c. *Size* is a weaker kind of glue, prepared from scraps of parchment, &c.

Leather.—Solutions of gelatin and tannin, when mixed together, produce an insoluble precipitate, which, in fact, consists of leather in flocks. When the solid skins of animals (hides) are made to undergo a proper treatment with substances which contain tannin, they become leather. The tendency to putrefaction is stopped, and the flexibility and the tenacity of the skins is improved. This operation is called *tanning*, and the art is one of great utility. Leather is indispensable for shoes, gloves, harness, coaches, fittings of furniture, the binding of books, the construction of travellers' trunks, and innumerable other purposes. See page 474.

Bones.—Examined at page 325.

NUTRITION OF PLANTS.

Between pages 9 and 13 of this work I have noticed the occurrence in organic substances of 17 elements or simple bodies; and at page 542 I have shown that of these 17, no less than 12 occur in milk and in eggs. Of the other 5 elements, silicon is abundant in straws, rushes, &c.; aluminum and manganese are found in extremely small quantities in plants and never in animals; iodine constantly occurs in sea-weeds and sponges, and fluorine is found in the bones of animals, and no doubt, therefore, occurs in some description of plants.

As plants are not gifted with the power of locomotion, all the elements which are requisite for their growth and reproduction must be brought to them, either by the atmosphere, upon which their leaves act, or by the soil in which they are planted, and from which their roots absorb whatever their systems require. In a state of unaided nature, wild plants grow and flourish in the soils which are suited to them, and elsewhere speedily die. The business of the farmer is to assist nature, so that plants may be made to grow in soils which are not naturally, or not at all times, suited to them. With that view he puts into the earth, where the seed of the desired plant is to be sown, materials which, by reaction on the soil, or on the air of the atmosphere, or on the water to be supplied by rain or irrigation, will produce such soluble substances as the roots of the plant will take up, and the power of vegetable life within it will convert into suitable nourishment.

I have shown that, as far as regards the three materials which form the visible mass of plants and their chief juices, we have them in carbonic acid and water, supplied in part by the atmosphere, and in part from the decomposition of organic substances in the soil. The additional element which is necessary for the production of *flesh-forming compounds*—nitrogen—is supplied to plants in the form of ammonia, either by the decomposition of nitrogenous substances mixed in the soil,

or from carbonate of ammonia and nitrate of ammonia brought down from the atmosphere by rain.

The inorganic materials of plants are supplied, partly from the decomposition of the minerals which constitute the soil, partly from the substances which are applied by the farmer in the form of manures. Thus, farm-yard manure supplies to the soil many of the substances which the growth of crops of plants removes from the soil. But the manure of a given farm-yard does not restore to the soil of that farm the ingredients which entered into the seed of the plants grown upon it for food, and which were carried off in that seed for consumption in some distant quarter of the world. On each farm, in each field, these abstracted ingredients require to be restored by some process of agricultural art before the exhausted soils can again give good crops of the same plants.

All soils contain silica, alumina, and lime. These earths occur together in very different proportions. When the first predominates, the soil is said to be *sandy*; when the second is in excess, it is said to be *clayey*; when the third predominates, the soil is called *calcareous*. When a deficiency of any of these earths occurs, it is remedied by the addition of the one that is required. Owing to the general prevalence of sands and clays, the deficient earth which it is commonly necessary to supply to bring the others into equilibrium is lime. This is sometimes applied in the form of carbonate, and sometimes burnt into quicklime. In this latter state, when assisted by rain, it more effectually attacks and decomposes the aluminates and silicates of the soil, and produces a variety of soluble salts, of which the plants absorb as much as they require.

Magnesia is supplied in that form of limestone or carbonate of lime which is called dolomite, and which contains both lime and magnesia. Iron and manganese occur so abundantly in all minerals, that every soil can yield the necessary supply. Sodium can be supplied, partly as sea salt, in which case it introduces also the chlorine that may be required by the plants, or it may be applied as nitrate of soda, or as an ingredient in many forms of mixed manure. Potassium can be supplied in the form of any salt of that metal; but as these salts, even the crude nitrate and chloride, are expensive, and so soluble as to be easily washed away from the soil by rain, the farmer prefers to depend upon the separation of potash from felspar, augite, and other components of the soil, by gradual decomposition in air and moisture, or to supply it in wood ashes, or as an ingredient in the more complex form of manure, such as guano, silicate of potash, &c.

Sulphur is supplied to soils in the form of a variety of sulphates, such as sulphate of lime or gypsum, sulphate of soda (Glauber's salt), and sulphate of ammonia—in all of which salts the bases are useful as well as the acid. Phosphorus is supplied in the state of bone-dust, or

solution of bone-dust in sulphuric acid, or in the condition of coprolites, or other varieties of the mineral phosphates of lime.

Different plants require these inorganic ingredients in very different proportions, and it is the business of the agricultural chemist to study these relations, and the means of supplying, effectively and economically, each plant with those ingredients, which are proved to be necessary for the production of an advantageous crop. It is impossible to give a useful account of such a subject as agricultural chemistry without entering into practical details, which are inadmissible in a work of this elementary character and limited extent. In speaking of the *nutrition of plants*, I desire only to give the reader a notion of that wonderful arrangement of affinities by which the three kingdoms of nature—the mineral, the vegetable, and the animal—are kept in equilibrium, and made to carry out, in the simplest and most orderly manner, the commands of the Creator. The mutual chemical attraction of four elements enables them to sweep out of the atmosphere all the compounds that would be injurious to the health of men and beasts, and which, if permitted to accumulate, would finally destroy all animal life. These compounds, destructive of animal life, form the food of plants, produce the bodies of plants, and yield finally the substances which serve as food to men and animals. These in their turn produce those deleterious compounds which poison the air for animals, but serve as food for plants; and when they die, the disintegrated materials of the bodies of men and animals serve also to promote the growth of plants. There is, consequently, a continual circulation of elementary atoms through the three kingdoms of nature; each is dependent upon the other; each works together with the other for good; nothing is useless; nothing is lost; nothing is wasted; nothing, under any circumstances, is destroyed or annihilated. The animal cannot live without the vegetable, by whose agency his food is prepared from the mineral elements and the refuse products of animals. The vegetable, on its part, would die of starvation but for the carbonic acid and ammonia which result from the actions of animal life. Without plants and animals, the world would be an arid desert, instead of being covered over its whole surface with the beautiful products of vegetable and animal existence.

COMBUSTION. FUEL. ILLUMINATION. FUSION.

I have so frequently had occasion, in the preceding pages, to notice examples of combustion, that it seems superfluous to recur to the subject under a special head. But there are two or three points of a general nature which require specific treatment in order to put the subject steadily before us.

The kind of combustion now to be treated of is that which produces heat and light, under circumstances in which the heat and light can be

usefully applied to the purposes of heating and lighting. It is not always that the heat and light resulting from combustion can be so applied. When, for example, nitrogenous substances, such as wool, hair, feathers, leather, bones, &c., are burnt, heat and light are produced, but they are accompanied by a disengagement of ammonia gas and of other suffocating compounds, which render it impossible to make useful applications of the heat and light resulting from these combustions. So, also, when brimstone is burnt, the production of sulphurous acid gas, and when phosphorus is burnt, the production of an atmosphere of solid phosphoric acid, render the heat and light produced by these combustions insusceptible of profitable applications.

It is quite otherwise with the compounds which belong to the saccharine or vinylate group. The products of their combustion present no obstacles that insurmountably hinder their applications in the arts and in domestic economy, and these are, consequently, the compounds which are universally resorted to when artificial warmth and illumination are to be produced by the combustion of substances which yield heat and light.

I propose, then, to take into consideration the transformations which occur during the combustion of a tallow candle, and during the preparation and combustion of coal gas. The consideration of these two topics, with a few words on spirit lamps and charcoal furnaces, will give us a sufficient view of the general relations of this subject.

In the preceding account of the constitution of compound radicals I have endeavoured to trace their origin and development, from the most simple forms up to those complex kinds which constitute the fatty and waxy radicals. I have now to show how the action of heat splits up these complex radicals into a variety of simpler radicals, and finally transforms them, by combination with oxygen, into carbonic acid and water—compounds which are thrown into the atmosphere, to be again absorbed by plants; to be again converted into sugar, and starch, and wood; again to serve as food for animals; and thus to continue the never-ceasing round of organic reactions. The circumstances which attend these combustions are consequently well worthy of careful observation.

Inquiry into the Phenomena which attend the burning of a Candle.

Tallow is a mixture of several kinds of fat, and its composition is subject to great variations. It may, however, be represented with sufficient accuracy for our present purpose by the formula,

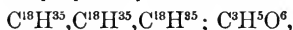

which represents the compound commonly called Terstearin, and which according to my notion of its constitution, as fully explained at page 37 of the "Radical Theory in Chemistry," and at page 429 of this work is a salt containing three atoms of the radical stearyl, each equal to $C^{18}H^{35}$, one atom of the radical glycyll, equal to C^3H^5 , and six atoms of

oxygen; these constituents presenting a total of $C^{57}H^{110}O^6$. The combustion of this salt converts the carbon into carbonic acid and the hydrogen into water. The 57 atoms of carbon demand for this purpose 114 atoms of oxygen, and the 110 atoms of hydrogen demand 55 atoms of oxygen, making together 169 atoms, towards which the salt provides only 6 atoms, leaving 163 atoms of oxygen to be taken up from the atmosphere in which the candle is burnt. 163 volumes of oxygen exist in 815 volumes of air. This consideration is sufficient to show why a large quantity of air is necessary to sustain the combustion of a candle, and why its flame so speedily expires if the access of air is restricted.

The following apparatus shows experimentally the relation of combustion to ventilation. Fig. 402 represents a large glass bottle, with a wide mouth, through which a candle and candlestick can be introduced. The candle is lighted, and the bottle is then closed by a cork, through which two narrow glass tubes are passed, one of them, *b*, terminating just beneath the cork, the other, *a*, passing down nearly to the bottom of the bottle. As the candle burns, the warm air, including the vapour of water and the carbonic acid, passes out of the upper tube, while fresh cold air enters by the long tube, and thus provides oxygen to support the combustion of the candle. If the long tube is closed, air ceases to enter the bottle, and the candle ceases to burn.



402.

Fig. 403 gives us an idea of the ordinary condition of the flame of a candle. We can clearly distinguish three parts—an inner dark part, *a*; a central bright part, *b*; and a thin outer casing of blue flame, *c*.

What takes place during the combustion appears to be this:—The heat melts the tallow, which rises in the wick by capillary attraction. It is there exposed to greater heat, and is resolved into vapour, which fills the dark central space, *a*. By some authors this space is described as being filled with the gaseous products of decomposed tallow; but I shall prove by an experiment that that notion is erroneous, and that the central space contains undecomposed tallow in vapour, condensable again to solid tallow; not, perhaps, into tallow of the same composition as that which forms the candle, but into a mass which at any rate is a solid fat and not a gas. However, the vapour of tallow produced in the space *a*, is soon acted upon by the heat, and the greater part of it is probably decomposed into olefiant gas (vinyl) = CH^2 . The combustion of this gas requires, of course, three atoms of oxygen for every atom of gas:—



403.

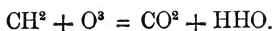

The oxygen, when deficient in quantity, combines at first with the hydrogen in preference to the carbon, and the consequence is that, for a moment, the carbon, separated from CH^2 , exists in a free state in the flame which is produced by the combustion of the hydrogen, and, being raised to a white heat by that flame, produces the bright light of the candle. There would be no white light produced by the flame were it not for the presence of the ignited particles of solid opaque carbon, since hydrogen burns with a blue flame, which has no illuminating power. I shall show presently, by an experiment, that such solid particles of carbon actually exist in a free state in the middle part, *b*, of the candle flame.

The hydrogen being thus first consumed, the arrival of more air affords the means of burning the carbon, which takes place in the outer and upper part of the flame, the part marked *c* in the figure, where also a quantity of hydrogen is burnt simultaneously.

These facts can be pretty well established by experiments made with the apparatus which is represented by fig. 404. Letter *A* represents a glass syphon about 30 inches in length from end to end, and $\frac{1}{4}$ of an inch in the bore. It is held in position by the support *B*. The shorter end of the syphon is fixed at about 3 inches distance from the bottom of a glass beaker, which is placed upon a table support, *C*. *D* represents a lighted tallow candle having a pretty large wick.

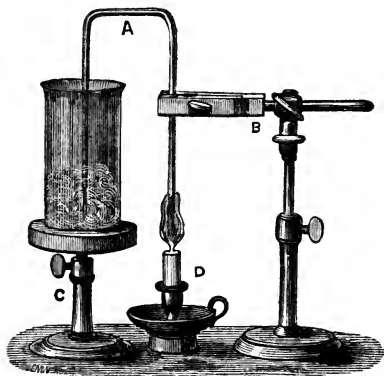

404.

This being the apparatus to be used, the experiments to be performed with it are as follow:—

a). Lift up the candle until the lower external end of the syphon nearly touches the top of the wick. Then hold it steadily. In a short time a white vapour will be seen to rise in the tube, and will flow down the other branch in a stream, and settle in a layer upon the bottom of the beaker, forming a white mass of distilled tallow. Of this tallow any quantity can be transferred into the beaker by continuing the process.

b). Lower the candle until the end of the syphon rests in the middle or bright part of the flame, the part which is marked *b* in fig. 403. An immediate change will be seen to take place in the product of the distillation. The interior of the syphon becomes black, and the vapour that passes from the candle into the beaker is fully charged with par-

ticles of solid opaque black carbon (soot), affording sufficient evidence of the decomposition of the tallow, and the separation of the hydrogen from the carbon in the department of the flame marked *b*.

c). Again, lower the candle until the end of the syphon merely touches the top of the outer case of flame, which is marked *c* in fig. 403. If this movement is made gradually and slowly, you will perceive that as you lower the candle, that is to say, as you raise the end of the syphon towards the top of the flame, the current of particles of carbon rapidly decreases, and finally ceases. What then passes through the syphon is carbonic acid gas and vapour of water, the two products of the perfect combustion of the tallow of the candle.

d). If you now reverse these trials, that is to say, if you gradually raise the candle, all other parts of the apparatus remaining fixed as they were, the above results will again appear in the inverse order of the above description, first the transfer of carbon will be observed, and finally the distillation of the vapour of tallow.

e). That the products of the complete combustion of tallow are carbonic acid gas and vapour of water, can be readily demonstrated by experiments, which I have already explained. At No. 11, page 346, I have described an apparatus by which the carbonic acid gas can be collected for examination, and at experiment 1, page 213, an apparatus for collecting the water which is given off by a burning candle.

Here, then, we have a concatenation of evidence. The tallow is liquefied in the wick; it is volatilised into the space *a*; it is decomposed in the space *b*, where the hydrogen is burnt and the carbon is separated and rendered incandescent; the carbon is burnt in the space *c*; the products of the combustion are carbonic acid and water.

If a piece of fine iron wire gauze containing about 40 meshes to the lineal inch is brought down over a candle flame, as shown by fig. 405, part of the flame is extinguished. It does not go through the meshes of the gauze, because the effect of the metal wire of the gauze is to cool down the heat of the flame and extinguish it. The smoke and combustible vapours pass through the gauze, but not the flame. The piece of gauze should be 7 or 8 inches in diameter, to prevent the flame from creeping round the edge to the upper side. When the vapour rises above the gauze, if a light is applied another flame is produced, independently of that which burns below the gauze. This fact, that flame cannot pass through metallic holes of a very small diameter, is the principle upon which Davy's safety-lamp is founded. See page 491.

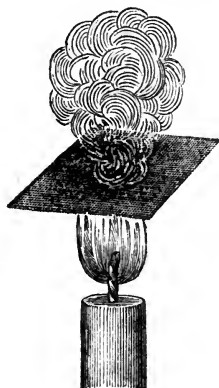

405.

Preparation of Coal Gas.—The necessary apparatus is shown in fig. 406. It consists of a hard German glass tube about 6 inches long and 1 inch in diameter, *a*, to which is adapted, by a cork, a hard

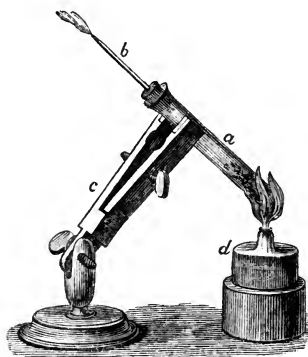

406.

Bohemian glass tube, *b*, about $\frac{1}{4}$ of an inch bore, with a fine orifice. A suitable support with a joint, *c*, holds this apparatus at a proper height above a spirit-lamp, *d*. Put into the tube *a* some splinters of cannel coal, or of other good coal that will burn with flame, about enough to fill an inch of the tube. Adapt the tube *b*, and apply the flame, at first gradually, and finally so that the flame covers the mass of coal. You will shortly observe a white vapour passing up the tube *a*, and out of the orifice of the jet *b*. When this smoke is strong and regular the atmospheric air will be all driven out of the tubes, and you

may then, without the danger of explosion, light the jet of gas at the end of the tube *b*. It will burn for some time with a bright luminous flame like a gas-light. A quantity of coke will remain in the tube *a*, and round the upper part of that tube will be found a quantity of coal-tar, mixed with strong water of ammonia, which may be tried with test-paper, and will be found to make red litmus blue, or yellow turmeric brown. These products have, of course, the usual offensive odour of coal-tar.

Separation of the Products of the Distillation of Coal.—By means of the apparatus represented by fig. 407, the foregoing experiment may be

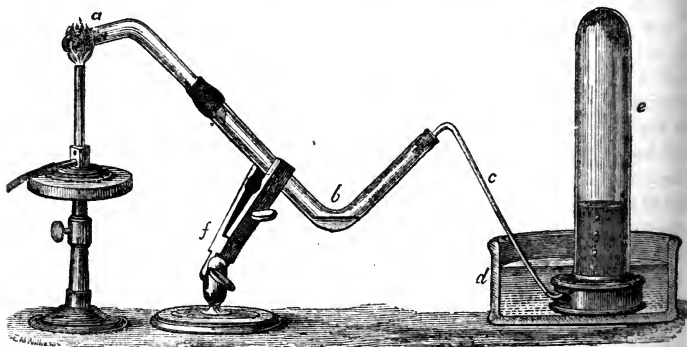

407.

performed so as to illustrate the manufacture of coal-gas more completely. A knee-shaped tube of hard glass, of about half an inch in diameter, *a*, is adapted by a cork, or caoutchouc connector, to a V-shaped glass receiver, *b*, to which is attached by another cork the gas-delivery tube, *c*, to convey the gas produced by the experiment through the pneumatic trough, *d*, into the receiver, *e*. The entire apparatus is supported by the stand, *f*. The closed branch of the tube *a* must be placed nearly horizontal, and the two ends of the tube *b* must be placed in the position shown by the figure. About a cubic inch of splinters of cannel coal is placed at the closed end of the tube-retort, *a*, and the flame of a spirit-lamp or of a gas-burner is applied to it. The coal is decomposed, and the products of the distillation are distributed as follow:—The coke remains in the tube *a*, the gas goes into the receiver *e*. Two liquid products condense in the angle of the tube *b*, and, after some time allowed for settling and separation, you find the lowermost of these two liquors to be a colourless transparent liquid, which is chiefly a solution of ammonia in water, and the uppermost to be a brown liquid consisting of the numerous substances which occur in coal-tar. In fact, both these liquids are of a very complex constitution. The coal-gas which passes into the receiver *e* has a very offensive odour. It may be partially purified if you put between the receiver *b* and the gas-tube *c* another tube or washing-bottle containing a solution of acetate of lead, which will absorb and separate sulphuretted hydrogen gas, and leave the residual carburetted hydrogen gas in a state of much greater purity. Such an apparatus is represented in fig. 408, in which the

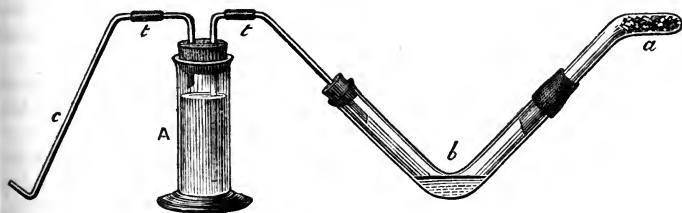

408.

parts *a*, *b*, *c*, correspond to the similar parts in fig. 407, while *A* is the vessel containing a solution of acetate of lead, through which the gas is to be passed, to be washed from sulphuretted hydrogen, and *t*, *t*, are connecting tubes formed of vulcanised caoutchouc.

This very simple experiment develops the whole art of gas-making. The coal, which must be of a kind that contains a large proportion of hydrogen, such as cannel coal, or the superior descriptions of caking coal, is heated in close vessels (retorts). The carbon takes up a quantity of hydrogen, more or less according to the quality of the coal, the temperature of decomposition, and other attendant circumstances, and forms

a mixture of hydride of methyl = H,CH^3 , and vinyl = CH^2 . The more it contains of the latter the better is the quality of the gas, and the greater its illuminating power. All other ingredients which occur in the mixed gases may be called impurities. Two of the most offensive of these are produced by the sulphur afforded by the iron pyrites of the coal, namely, sulphide of carbon = CS^2 , and sulphide of hydrogen = HS , the special characters of which are given in the sections relating to these compounds. It is chiefly to these two gases that the unpleasant odour of coal-gas is due. The sulphide of hydrogen can be separated by several reagents, but not the sulphide of carbon, and when this is burnt in company with the gas it produces sulphuric acid, frequently in such quantity as to be unwholesome and to act injuriously upon furniture, books, &c., which are exposed to it in dwelling-houses, warehouses, and libraries.

The products of the distillation of coal performed in the large way, for the production of gas to supply a town, consist of a great variety of compounds, some of them very complex. I allude to those which mingle in the above experiment with the gases collected in the receiver *a*, and with the liquids in the bent tube *b*. The total quantity of products obtained in this elementary experiment is too small to permit of their separation and individual examination; but I may, nevertheless, enumerate the most important of them, to show how great a variety of substances can be produced by what seems to be the simple operation of burning a piece of coal incompletely. The result is surprising; for when the coal is completely burnt, in the open air, it yields scarcely anything but carbonic acid, water, and ashes. Whereas, on being distilled, it can yield all the compounds that are named in the following list:—

Gases: Hydride of methyl H,CH^3 , Vinyl CH^2 , hydrogen, carbonic oxide, carbonic acid, sulphide of carbon, sulphide of hydrogen, ammonia, cyanogen, with a quantity of the hydrocarbons in vapour.

Thin Liquid. Water containing ammonia, with benzole, toluole, and cumole. These three hydrocarbons constitute together the chief part of what is called *coal naphtha*.

Thick Liquid. As a mass of viscous matter, this is called *coal-tar*. It contains the following basic substances: ammonia, aniline, picoline, quinoline, and pyridine. The following acids: acetic acid in small quantity, phenic acid = $\text{H,C}^6\text{H}^5\text{O}$ in large quantity. The following neutral substances: benzole, toluole, cumole, cymole—these four are liquid; while naphthalin, paranaphthalin, chrysene, and pyrene are among the neutral substances which, when separated from these liquids are solid at ordinary temperatures.

Solid Product. Porous coke, including the ashes of the coal.

The gases are purified for use by being passed through liquids, or over moist solids, of a kind that will absorb or destroy the gases which

are unpleasant or deleterious, or which do not burn with illuminating power. The substances used in the large way for this purpose are hydrate of lime, hydrated oxide of iron, and dilute sulphuric acid. Acetate of lead, useful in an elementary experiment, is too costly for use in the arts. The value of the gas is in direct proportion to its quantity of vinyl = CH^2 , because the combustion of that gas gives the most brilliant flame. Hydride of methyl = H_2CH^3 , gives a much less amount of light. The vapours of some of the dense hydrocarbons dissolved in the gas increase its light, but as cold reduces them to the liquid state, in which they clog the pipes, they are inconvenient. The other impurities are removed by the reagents above mentioned. This purification, especially from sulphide of hydrogen and ammonia, is indispensable to render the use of gas in dwelling-houses comfortable and safe. Carbonic oxide and hydrogen are useless for illumination, but they cannot be separated, and they burn with the hydrocarbons. Of course, in the manufacture of coal-gas for sale, care is taken, or ought to be taken, to regulate the process of distillation so as to produce as much as possible of the useful gases, and as little as possible of those which are mischievous or useless.

The *Coal-naphtha* and *Coal-tar* above referred to are subjected to a variety of processes, by which the ammonia, benzole, and other useful compounds which they contain, are separated and purified.

Diagram of a Gas-work.—The publisher of this volume has published a diagram for use in schools, which exhibits the chief processes that are followed in a public gas-work. The size of the diagram is 63 inches by 33 inches. In the background is given a general view of the buildings in a gas-work, and in the foreground are sections of the principal apparatus, showing the progress of the gas, from the retorts in which it is made, through the condensers, purifying vessels, meter, and governor, into the main pipes, for distribution to the public. The reader of the following description is supposed to be looking at the picture.

All through the diagram, the space occupied by the gas is coloured *yellow*, and the pipes through which the gas passes are coloured *blue*, whether seen in perspective or in section. The retorts in which the coal is distilled are perceived on the left hand, two of them in perspective and one in section. A gas-pipe rises vertically from each retort, bends over at the upper end, and dips into a large horizontal pipe, in which a quantity of tarry matter is deposited. A large pipe carries the gas into a condenser, where more of the tarry matter is deposited, and from the condenser the tarry matter passes by a syphon into a deep reservoir or well. The gas then passes through a series of vertical pipes, of which ten are shown in the diagram, in which, by the cooling action of atmospheric air, and occasionally of water applied to them externally from a tank coloured green in the diagram, the gas is cooled,

and made to deposit much more of the tarry matter, which descends through the lower open ends of the vertical pipes into a cistern placed below them, and thence by another syphon into the well. The gas, thus cooled, and deprived of most of its liquid and tarry impurities, is now passed through vessels in which it is acted upon by various chemical substances, liquid and solid. The methods of purification differ in every gas-work. Two plans with liquids and two with solids are shown in the diagram. In the first purifier the gas is pressed under the liquid, with which it is mixed by a series of floats fastened to a belt which passes over revolving wheels. These floats, by acting against the current of gas, mix it thoroughly with the purifying liquor. In the second liquid purifier a set of horizontal paddles are connected with a vertical shaft which is made to revolve by mill-work. The gas in passing through the purifier comes into contact with these revolving paddles, and is thereby agitated with the liquor. The gas now rises to the dry purifiers. It enters at the bottom on the right hand, passes upwards through three layers of hydrate of lime spread on porous trays, and then entering into the next compartment of the purifier, it descends through three layers of hydrated red oxide of iron, also spread on porous trays, and it escapes at the lower left hand side of the purifier.

The gas, supposed to be now sufficiently pure for use, is conveyed into the gasometer, which is a large metal bell, suspended by counterpoises over water, or over a mass of brickwork, with a water-lute round the sides. The form of gasometer shown in the diagram is the telescope form, which consists of two parts, one moving within the other. The inner one first becomes filled with gas, and then it becomes enlarged by pulling up the outer portion. The diagram shows that they are connected together by a water-lute. The gasometer is made in the diagram much too small in comparison with the other features of the gas-works. The two other gasometers shown in perspective in the background give a better idea of their correct proportions.

The last object shown in the diagram is the governor, the use of which is to regulate the distribution of gas in the mains or pipes which convey the gas to the public. The governor consists of a conical plummet suspended to a counterpoise, so that by rising or sinking it closes or opens, more or less, the space by which the gas passes from the gasometer into the mains. If the pressure is stronger in the gasometer than in the mains, the plummet sinks, and gas passes into the mains. If the pressure on the gasometer becomes lessened, or that in the mains increases, the pressure acting on the bottom of the plummet causes it to rise and cut off the flow of gas from the gasometer.

I proceed now to notice the applications of gas flame as a source of heat, particularly useful in chemical operations.

Flame with Illuminating Power.—In many cases of combustion, flame is produced which has no useful illuminating power. I have instanced the combustion of sulphur and phosphorus. I might also adduce examples of gases in cyanogen, carbonic oxide, and pure hydrogen, which burn with flame, but not with useful light. When we want brilliant and manageable flame, we burn compounds of hydrogen and carbon. The reason why those compounds give a brilliant flame has been explained.

These useful combustibles are to be sought for among the compounds of vinyl, such as oils and fats, or in compounds such as coal, resin, and bitumen, whose decomposition affords vinyl, or some of its salts. The gas produced in the flame of a candle and the purified mixture of coal-gas may vary much in composition, and in their relative proportions of CH^2 and H,CH^3 , but all these mixtures burn with oxygen into carbonic acid and water, giving a bright flame.

Flame without Illuminating Power.—The brightness of flame generally depends upon the presence of a large quantity of carbon in proportion to the quantity of hydrogen. But it is also influenced by the proportion of oxygen which is present, and the manner in which the oxygen is supplied. Coal-gas contains no oxygen, and it burns with the brightest light. Vapour of tallow contains some oxygen, and it burns with a less brilliant flame. Vapour of alcohol contains a large supply of oxygen ($= \text{C}^2\text{H}^6\text{O}$), and it burns without brilliancy. But it is also possible to burn coal-gas so that its flame shall have no brilliancy. In the gas-burner which is represented at page 336 gas enters by the flexible pipe, and is mixed with atmospheric air, which enters by the small holes near the base of the tube. The mixture thus made in the tube burns at the mouth with a flame which resembles that produced by a spirit-lamp. It has no brilliancy, and gives no smoke. The same effect is produced if gas is passed into a cylinder open at the bottom and covered at the top with a wire gauze like that of the Davy Lamp. (See fig. 405.) The gas mixed in the cylinder burns at the top with a pale-blue non-illuminating flame, free from smoke. Upon this principle the chemical gas-burner, fig. 409, is constructed. A third example will be shown in a subsequent piece of apparatus, where air is forcibly blown into the middle of a

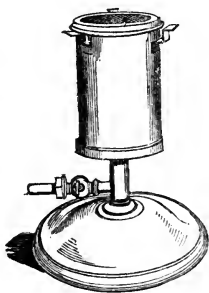

409.

jet of gas. In that case, also, the flame is without brilliancy and without smoke. If you bring down a piece of white card over a white flame, such as that of a candle, a lamp, or a gas flame burning at a single large round hole, the card will be blackened with smoke, but when it is brought into a blue flame it is not blackened. These facts

seem to prove that when there is a comparative deficiency of oxygen the hydrogen burns first, and the carbon afterwards. When there is a sufficiency of oxygen in every part of the mixed gases both elements burn at once. The carbon, *perhaps*, is first converted into carbonic oxide gas, and that burns, with the hydrogen, and like the hydrogen, with a blue flame. At any rate, when plenty of oxygen is present, there is no sign of that whiteness in the flame which betokens the presence of incandescent solid carbon. It is, no doubt, in consequence of the completeness of the burning which is thus effected, that the blue flame of gas possesses so much greater a degree of heat than the white flame, and that the flame of a spirit-lamp is so much more powerful than that of a candle. To produce much light, oxygen must be supplied to the hydrocarbons outwardly and gradually. To produce great heat, it must be mixed with the hydrocarbons, and supplied in excess.

Combustion without Flame.—All varieties of carbon which are free from hydrogen, such as charcoal, coke, anthracite, and graphite, necessarily burn without flame. The product of the combustion, when the supply of oxygen is insufficient, in consequence of slow draught, or any other cause, is carbonic oxide; when the supply of oxygen is abundant the product is carbonic acid. When the above descriptions of fuel are used in a furnace where there is a good draught, or a strong blast of air, great heat is produced; but the heat diminishes when the supply of air is lessened; so that in an open fire-place coke, anthracite, and graphite do not burn readily. When air is drawn through a furnace by means of a tall chimney, it is called a *wind* furnace. When air is blown into a furnace by means of machinery, it is called a *blast* furnace.

THE USE OF COAL GAS, AS A SOURCE OF HEAT IN CHEMICAL OPERATIONS.

I have had occasion, in the preceding pages, to describe gas-burners of several different patterns; such as the cylinder gauze burner, fig. 409, page 561; Bunsen's single jet for mixed gases, fig. 330, page 336; and Bunsen's triple jet, fig. 243, page 241. The greatest heat produced by a gauze burner lies in a horizontal line at about the sixth of an inch above the gauze, and rises not more than a quarter of an inch. In that line the heat is very great. Above that line it is much more moderate. The jets, on the contrary, give a tall bulky flame, in which a small object, such as a crucible, can be entirely enveloped, and thus be subjected to a considerable heat, cut off from contact with atmospheric air. The flame also having the faculty of playing about like the flame of a spirit-lamp, can be made to expand under an evaporating basin, or a retort, and so be made to effect evaporations, boilings, and distillations. A four-jet burner will give a spread flame of 5 inches diameter.

I now proceed to describe some burners of a more general, or a more powerful character.

Gas Apparatus for Boiling or Evaporating.—Fig. 410 represents a gas-burner suitable for boiling, distilling, or evaporating large quantities of liquid. *a* represents a cone of brass, open at the bottom and covered at the top with fine wire gauze. *b* is the pipe which brings in the supply of gas. *c* is a pair of dampers, moveable by the handles *d*. They can be so arranged as to leave the gauze top almost quite free, or to cover the greater portion of it. *e* are three supports to hold an evaporating basin, kettle, still, or other vessel, over the flame, and pretty close to the gauze.

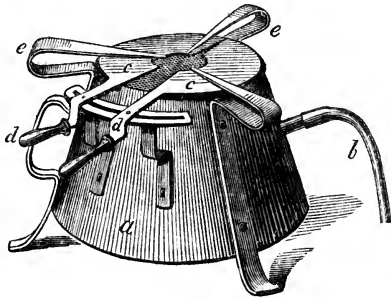

410.

The apparatus is made 4 or 5 times the size of the figure.

The movability of the pieces *c*, permits the heat to be applied moderately or powerfully according to the demand of the experiment; and by a proper management of the gas stopcock attached to the tube *b*, an economical and expedient use of the gas can be made.

A different and more powerful description of evaporating furnace is produced by using a circle or a group of Bunsen's single jets, within a cylindrical jacket; the number of jets being varied according to the quantity of heat in request.

Bunsen's Gas Apparatus for Heating Crucibles.—In this apparatus, a considerable number of jets are combined and used together. It is represented in fig. 411, at about one-sixth of the full size. Air enters into the tubes near the base, as in the single jets, and mixes in the tubes with the gas, which is brought in by the flexible pipe. There is also a chamber in the body of the apparatus, so contrived as to mix

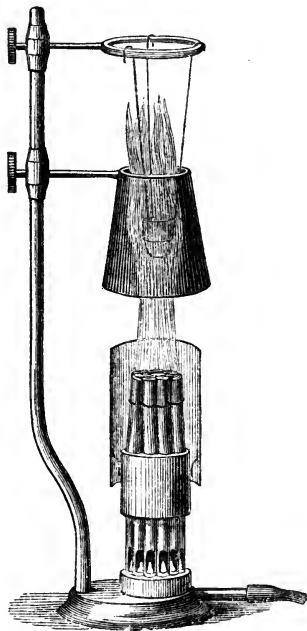

411.

the air thoroughly with the gas. The mixture then passes out by a bundle of tubes, eight in number, bound close together, so as to make a single flame of great power. A moveable jacket is placed round this bundle of tubes, partly to bring additional air to the flame, and partly to cut off the action of disturbing currents of air. The crucible to be heated is suspended within a crucible-jacket by platinum wires, as is shown in the figure. The two jackets are adjusted more or less closely to one another, according to the bulk of the crucible, and the power of the flame, or the degree of heat that may be required for the special object of an experiment.

Hess's Crucible Furnace.—In this furnace, which is represented by

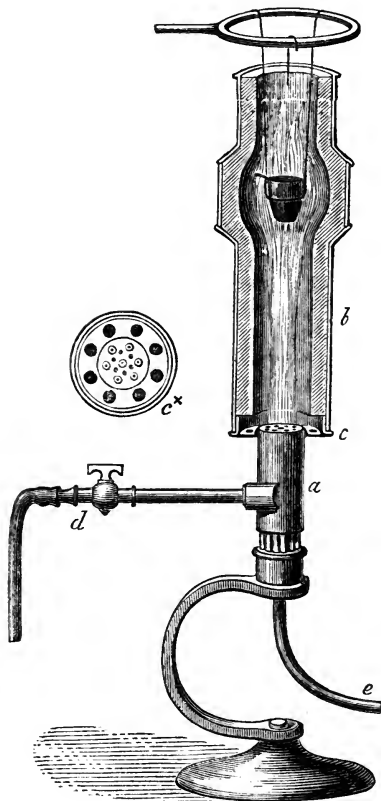

412.

figure 412, the gas is mixed with air in the body of the apparatus marked *a*. The gas is supplied by the pipe *d*, and the air is blown into it by a bellows or blowing machine by the pipe *c*. The flame rises into the chimney *b*, in the widened part of which the crucible is suspended by wires from a retort stand, a ring of which is shown in the figure. The chimney is constructed of iron, and lined with fire-clay. Figure *c** is a ground view of the apparatus at the point marked *c*. The holes in the centre are those through which the mixture of air and gas rises from the body of the burner. The holes in the outer circle are provided to permit an additional supply to the flame in the chimney; the quantity of air which is forced into the apparatus by the blast applied to the pipe *c*, not being sufficient to insure the perfect combustion of the gas. This burner has sufficient power to melt three or four ounces of copper

Paris Gas Apparatus.—The gas apparatus represented

by fig. 413 combines a variety of modes of using gas as fuel, and is adapted for a great number of experiments. It is an apparatus that is used by

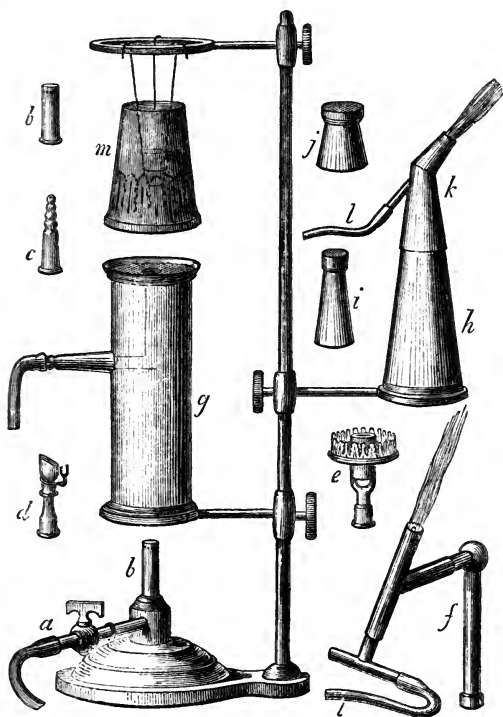

413.

Professor Deville and other eminent French chemists. The gas enters by the pipe *a*, which is regulated by a stopcock. Upon the solid foot of the support to which this stopcock is attached there is a screw, which fits a variety of burners suitable for different uses. The burner, represented in the figure as screwed to the foot, and of which there is a separate figure, also marked *b*, contains a circle of small holes round the side, near the top. This arrangement serves either to give a circle of small jets of gas for a diffusive heat suitable to evaporations, or to diffuse gas among air, previous to its combustion as mixed gas. *c* represents a single jet; *d* is a flat jet for use with the blowpipe; *e* is an Argand burner, with a gallery to hold a chimney. This can be used with a copper chimney when heat is required, and with a glass chimney when light is wanted. *f* is a burner provided with a double-

jointed movable nozzle, which can be fixed in any required direction, and in which there is a blowpipe nozzle adapted to the flexible pipe *l*, which on being connected with a bellows, gives a blast of air, or when connected with a gas-holder, containing oxygen under pressure, can supply a current of oxygen gas, so as to produce a most intense heat. With the bellows and common air, this burner answers for glass-blowing, heating small crucibles, and many other operations. When oxygen is used, many refractory substances can be fused or burnt in the jet. *g* is a cylinder of metal, open at the bottom, and covered with gauze at the top. This, when used, is brought down over the jet *b*, by altering the position of the thumb-screw on the vertical rod. This burner has then the properties of the burner represented by fig. 409, page 561. But additional power can be given to the flame by blowing into it, by means of the pipe represented in the figure, a current of air or of oxygen gas. The flame above the gauze becomes then more suitable for the ignition of a crucible. *h* is a brass cone open at both ends, and when used, it is to be brought round and depressed over the jet *b*, the cylinder *g* being removed. Three different burners are adapted to the top of this cone, namely, *i* and *j*, both of which are provided with gauze tops, and *k*, to which is adapted the blowpipe *l*, and which is to be used in the same manner in the burner *f*, *l*. When air and gas are mixed in the cone *h*, and burnt at the jet *k*, and oxygen gas is forced in at the blowpipe *l*, a most intense heat, capable even of melting platinum, is produced in the resulting jet. *m* is a crucible jacket which fits the top of the cylinder *g*, and in which crucibles to be heated may be suspended by platinum wires from the uppermost ring of the support. With this set of gas fittings, heat can be applied for chemical purposes under many modifications, such as—small flames and large flames, moderate heat or intense heat, white flames or blue flames, heat spread widely or concentrated to a point.

Bunsen's Regulator for Hot-Air Baths, employed to heat substances at any desired Constant Temperature.—Substances that are to be heated or dried at some constant temperature are put into a copper air-bath of the form represented in fig. 414, which is suspended against the wall of the laboratory, and heat is applied by a gas-burner *d*, put below the bath, and the distance of which is regulated by raising or depressing the fork on which it slides, and which is secured by a thumbscrew to an iron rod attached to the end of the bath. The regulation of the temperature is effected by increasing or diminishing the supply of gas to the burner *d*, which increase or diminution of the supply of gas is managed as follows:—The supply of gas enters by the tube *a*, and goes into the tube *b*, whence it passes by the tube *c*, to feed the burner *d*. At the bottom of the tube *b*, in the part which enters the air-bath, a quantity of mercury is placed. A glass tube which is a continuation of the gas pipe *a*, passes down the tube *b*, and

dips into the mercury. The depth of the dip is regulated in part by the quantity of mercury put into *b*, and in part by a screw in the upper part of that tube, by turning which the inner tube can be raised or depressed, or fixed at any desired point indicated by the scale which is attached to that part of the tube. This constitutes the regulator, and being thus prepared it is put into the bath, accompanied by the thermometer *e*, and the jet *d* is lighted, and raised or depressed, and the tube *a* is adjusted by the screw on *b*, until the desired temperature is obtained in the bath. If the apparatus is now left to itself, the temperature remains steady, provided the supply of gas remains constant, but not otherwise; and it is to nullify the irregularities which arise from variations in the supply of gas that the regulator is employed. The action of it is as follows:—When the quantity of gas delivered by the supply pipe *a* is increased, the heat rises, the mercury expands in the tube *b*, and increases the pressure upon the mouth of the tube *a* in such a manner as to lessen the supply of gas. On the contrary, when the quantity of gas diminishes, the heat falls, the mercury condenses, the pressure is lessened on the mouth of the tube *a*, and the supply of gas is increased. In this manner, a very constant temperature can be maintained for a long time in this air-bath; and this is a point of great importance in comparative experiments on many organic substances.

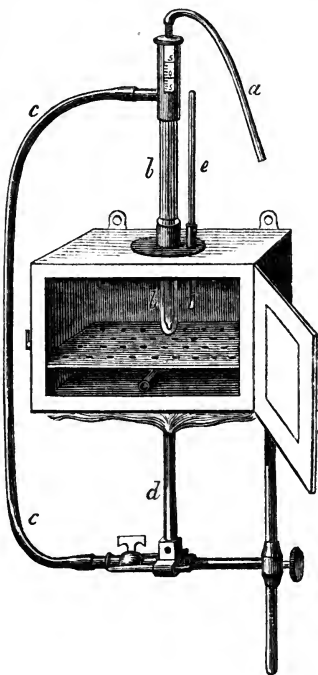

414.

GRIFFIN'S PATENT BLAST GAS FURNACE.

The Patent Blast Gas Furnace produces a much greater degree of heat than any of the apparatus yet described. It is capable of melting so many of the refractory metals, and in quantities that are so well adapted for the usual analytical experiments of philosophical chemists, as almost to supersede the necessity of using fixed furnaces, or portable blast furnaces, fed by charcoal or coke.

The apparatus consists of two parts, namely, of a particular form of GAS-BURNER, which is supplied with gas at the usual pressure, and

with a blast of common air, supplied by bellows or a blowing machine, at about ten times the pressure at which the gas is supplied.

Secondly, of a FURNACE, which is built up in a particular manner, round the flame that is produced by the gas-burner and the crucible that is exposed to ignition.

The object of the particular construction of this furnace is to accumulate and concentrate in a focus the heat produced by the gas flame, and to make it expend its entire power upon any object placed in that focus.

This apparatus can be made of various sizes, according to the amount of work which is required from it. I shall describe a few varieties of the furnace, and the results of some experiments made with them, which will show the reader what kind of work it is able to execute.

The Gas-burner.—The gas-burner is a cylindrical iron reservoir, constructed as shown in section in fig. 415, which is drawn on a scale of

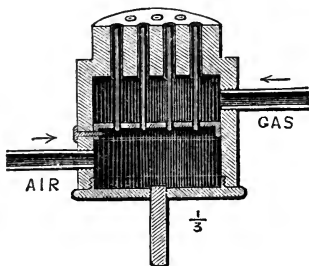

415.

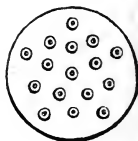

416.

one-third the full size. It contains two chambers, which are not in communication with one another. Into the upper chamber, gas is allowed to pass by the tube marked GAS. Into the lower chamber, air is forced by the tube marked AIR. The upper part of the burner is an inch thick in the metal. Through this solid roof, holes are bored for the escape of the gas. The experiments described hereafter were made with a burner that contained sixteen holes, arranged as shown in fig. 416, which is a surface view of the burner represented by fig. 415. But burners, with six holes, and with twenty-six holes, have been made for other purposes. The number of holes depends, of course, upon the heating power required from the burners. The air passes from the lower chamber, through a series of metal tubes, placed in the centre of the gas-holes, and continued to the surface of the burner, so that the gas and air do not mix until both have left the gas-burner, and then the current of air is blown through the middle of each jet of gas. The bottom of the gas-burner is made to unscrew, and the division between

the two chambers, which carries the air-tubes, is easily removable, for the purpose of being cleaned. The GAS and AIR pipes which I have used are both half an inch in the bore, and are ten inches long; the gas has usually had a pressure of half an inch of water, and the blast of air about ten times that pressure. The quantity of gas used in an hour was about 100 cubic feet. The stopcock which supplied it had a bore of half an inch. The round rod, which is represented at the bottom of the burner, fig. 415, is intended to fit it to the support, shown by *b*, in figs. 430 to 433.

When the gas is lighted and the blast of air is put on, the flame produced by the gas-burner is quite blue, and free from smoke. It is two inches in diameter, and three inches high, and the point of greatest heat is about two inches above the flat face of the gas-burner. Above this steady blue flame there rises a flickering ragged flame, several inches in height, varying with the pressure of the gas. In the blue flame, thin platinum wires fuse readily.

When the gas is burning in this manner, and the apparatus is attached to flexible tubes, the burner may be inverted or held sideways, without disturbing the force or regularity of the flame, so that the flame may be directed into a furnace at the bottom, the top, or the side, as circumstances may require.

The following articles are used in building up the gas furnace for different experiments. They vary in size according to the volume of the crucible, or the weight of the metal which is to be heated, but I may give a general idea of them by saying that figs. 417 to 429 are drawn of about one-sixth part of the actual size of the articles which they respectively represent. The scales of figs. 430 to 433 are marked upon them.

Fig. 417 represents a section of a circular plate of fire-clay, two inches thick, with a hole in the centre, which exactly fits the upper part

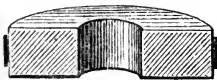

417.

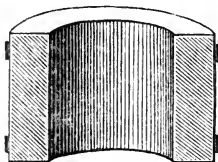

418.

of the gas-burner, which is made to enter into the hole three-quarters of an inch. In external diameter, this clay plate agrees with each size of furnace.

Fig. 418 represents a section of a cylinder of fire-clay, of which two pieces are required to constitute the body of each furnace. In the middle of each cylinder, a trial-hole is made, one inch in diameter, to which a fire-clay stopper is adapted.

Fig. 419 is a section of a fire-clay cylinder, closed at one end, and pierced near the open end with six holes, of half an inch in diameter. The thickness of the clay is immaterial. This cylinder is three inches high and three inches in diameter.



419.



420.



421.

Fig. 420 represents a circular plate of fire-clay, two and a half inches or three inches in diameter, and one inch thick.

Fig. 421 is a cylinder of plumbago, to be used as a crucible support. It is three inches in diameter, one inch in height and $\frac{1}{8}$ inch thick. It is pierced with twelve holes of three-eighths of an inch bore.

Fig. 422 is a similar cylinder of plumbago, two inches high, pierced with twenty-four holes of three-eighths of an inch bore.



422.



423.



424.

Fig. 423 is of the same nature and materials, but is three inches in height. It has twenty-four holes of three-eighths of an inch bore.

Fig. 424 is a thin plate of plumbago, three inches in diameter namely, of the same diameter as the above three cylinders. It has a small hole in the middle, and being of a soft material, the hole can be easily cut or filed to any desired size.

To suit the larger kinds of crucibles and furnaces, cylinders are made resembling fig. 423 in form, but of greater diameter.

As in all cases the heating power of the gas furnace spreads laterally and does not rise vertically, the most advisable form of the crucible required for use in it, is *short and broad*, not tall and narrow, and the supporting cylinders must be shaped accordingly. No fire-bars or grates can be used to support crucibles in this gas furnace, because a material, formed into narrow bars, can sufficiently withstand its power of fusion and combustion.

Fig. 425 is a plumbago cylinder, or crucible-jacket, two and a half inches high, two and a half inches in diameter, and a quarter of an inch thick in the walls. It has six holes of three-eighths of an inch diameter near one end.

Fig. 426 represents a circular cover or dome, flanged at the bottom, and having a knob or handle at the top. It is pierced with twenty-four holes of a quarter of an inch in diameter, arranged in two rows near the bottom. This dome, when of small size, is made of plumbago. When of large size, of fire-clay.

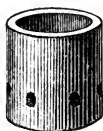

425.

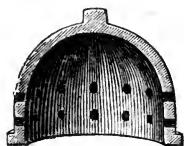

426.

Figs. 427 and 428 represent plumbago crucibles made with a solid overhanging rim, the use of which is to suspend the crucibles over the



427.



428.



429.

gas-burner, by means of the cylinders, figs. 421 to 423. When the crucibles are too small to fit the cylinders, the flat plate, fig. 424, is filed to fit the crucible, and is then placed on the cylinder, to whose diameter it is adapted.

Fig. 429 is an ordinary crucible of porcelain or platinum.

Besides these pieces of fire-clay and plumbago, it is necessary to be provided with a strong iron tripod, to sustain the furnace, as represented by *c*, in figs. 430 to 433; an iron pan, in which to place the furnace; and a quantity of gravel, or rounded flints, not less than half an inch, nor more than one inch, in diameter. These pebbles form an essential part of this gas furnace.

Gas Furnace, heated at the Top, exhibited in Section by fig. 430.—*a* is the gas-burner, fig. 415; *b* is the support for it, when used below the furnace; *c* is the iron tripod support for the furnace; *d, d'*, are two perforated clay plates, like fig. 417, adapted to the gas-burner *a*; *e, e'*, are two clay cylinders, like fig. 418. These pieces, *a* to *e*, are similar in all the furnaces represented by figs. 430 to 433, and will not require description in each example.

The interior of the furnace, as represented by fig. 430, is built up as follows:—The clay plate, *d*, is put upon the tripod, *c*. Over the central hole in *d*, the clay cylinder, fig. 419, is placed, and upon that cylinder two or three of the clay plates represented by fig. 420. Upon these a porcelain or platinum crucible, similar to fig. 429, is placed. If it is of platinum, a piece of platinum foil may be put between the crucible and the uppermost clay plate, to protect the

crucible from contact with particles of iron, or against fusion with the clay. The crucible is to be surrounded by the plumbago jacket, fig.

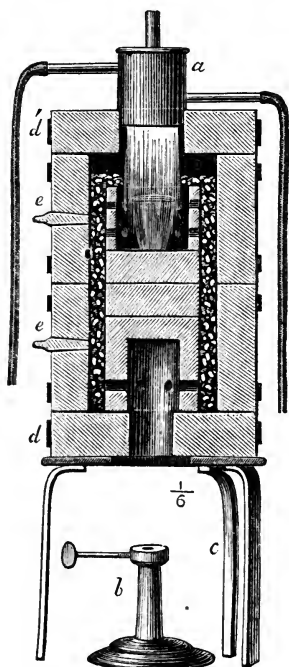

430.

gas-burner is to be depressed into the central hole of the clay plate *d*, as shown in fig. 430. The whole force of the blue flame then strikes the crucible; part of it forces its way through the holes in the jacket, fig. 425, and part of it rises and passes over the upper edge of the jacket; after which it forces its way downwards between the pebbles. The carbonic acid gas and the vapour of water which result from the combustion of the gas, together with the nitrogen of the air, and any uncombined oxygen, accompany it. No space being left open for the escape of these gases at the upper end of the furnace, they go downwards through the interstices among the pebbles, and passing through the holes in the cylinder, fig. 419, and through the central hole in the clay plate *d*, fig. 430, they escape finally into the air. In this progress, the hot gases give up nearly all their heat to the flint stones. Water and gases escape below at a very moderate temperature, water even runs down in the liquid state, while the stones rapidly acquire a white heat, and if the

425. The space between this pile in the centre of the furnace and the two cylinders, *e, e*, which form the walls of the furnace, is to be filled with flint stones, or gravel, washed clean and dried. The stones which answer best are rounded, water-worn pebbles, of half an inch to one inch diameter. These may be piled up to the top edge of the jacket, fig. 425. The number of clay plates, fig. 420, must be such as to bring the top of the crucible, fig. 429, to the distance of two inches, or two and a half inches at the utmost, from the flat face of the gas-burner, *a*. In some cases, merely one of the furnace cylinders, *e*, is necessary, in which case the crucible and its jacket is placed directly upon the cylinder, fig. 419, and when only a moderate heat is required, even the packing with pebbles may be dispensed with. Another means of diminishing the heat is that of increasing the distance between the gas-burner and the crucible.

The apparatus being thus arranged, the gas is to be turned on, and to be lighted, the blowing-machine is to be put into action, and the nozzle of the

blast and the supply of gas is continued, they retain that white heat for any desired length of time—for hours.

At the end of ten minutes after lighting the gas, the crucible, placed in the described circumstances, and exposed to the full action of the heat of the gas, and surrounded by substances which are bad conductors of heat, is raised, with the jacket and pebbles around it, to a white heat. The consequence is, that the full power of the gas jet is then exerted upon the crucible and its contents, and after a time those effects are produced which will be described presently.

If it is desired to inspect the substance subjected to the action of heat in this furnace, the gas-burner is lifted out, and the crucible is examined through the hole in the clay plate. To make it possible to inspect substances at a white heat, the view is taken through a piece of dark cobalt blue glass. If the substances submitted to heat suffer no harm from the action of oxygen, it is better to dispense with a crucible cover, and to direct the jet of flame directly down upon the substance to be heated. The action is then more rapid. When the burner is taken out, the substance in the crucible can be stirred, if it is considered necessary.

The following experiment will give an idea of the power of a furnace of this description. A common clay crucible, three inches high and three inches diameter at the mouth, was filled with about twenty-four ounces of cast iron. It was mounted like fig. 430, in a furnace of four inches internal diameter, and eight inches deep. The pebbles were filled in to the edge of the crucible. No crucible-cover and no jacket were used. The flame was thrown directly upon the iron. In a short time, the iron melted, the oxygen then reduced some of the cast iron to malleable iron, which formed a thin, infusible mass, on the surface of the cast iron. At twenty minutes from the lighting of the gas, the furnace was dismantled. The crucible was taken out. A hole was broken by an iron rod in the infusible malleable iron surface, and the fused cast iron below it was decanted into a mould, and made a clear casting weighing twenty ounces. This experiment is a sort of "puddling process," in a small way, and the result shows that within twenty minutes a heat is produceable in this little furnace which is more than sufficient for the decomposition of silicates by fusion with the carbonates of potash, soda, or barytes.

By breaking down the crust of malleable iron, stirring the melted cast iron, and continuing the heat, the *puddling process* above referred to may be imitated more closely. When I call the malleable iron *infusible*, I mean within the space of 20 minutes, and under the described circumstances, because I shall show hereafter that the power of this furnace is sufficient to fuse malleable iron.

In the same small furnace 32 ounces of copper can be fused in 15 minutes. When the furnace is hot, that quantity of copper or cast iron can be fused in 10 minutes.

Gas Furnace heated at the Bottom, exhibited in Section by fig. 431.

In this furnace the parts marked *a*, *b*, *c*, *d*, *e*, *e*, are the same as those similarly marked in fig. 430; but the gas-burner is in this case put into the bottom of the furnace, instead of the top, and the arrangement of the crucible and its support is altered in the manner shown by the figure. Upon the centre of the clay plate *d*, the perforated plumbago cylinder and cover, represented by figs. 421 and 424, are placed; and upon them a plumbago crucible of the form shown by fig. 427. The size of the crucible, and the height of the perforated cylinder, are to be so adjusted that the bottom of the crucible shall be struck by the hottest part of the gas flame; that is to say, the space left between the face of the gas-burner and the bottom of the crucible must not exceed $2\frac{1}{2}$ inches. The crucible is provided with a closely-fitting cover, and pebbles are then filled in between the crucible jacket and the furnace cylinder *e*, and are covered over the crucible until both the pieces of the furnace *e*, *e*, are filled. The gas is then

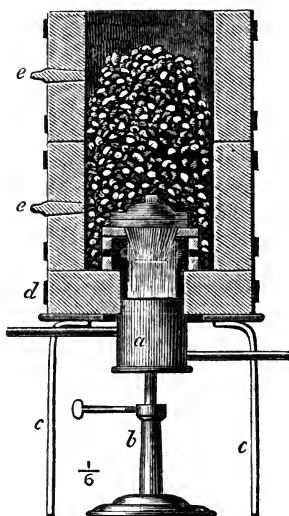

431.

lighted, the blast of air is set on, the gas-burner is forced up into the hole in the clay plate *d*, and the operation proceeds. In from ten to twenty minutes after the gas is lighted—this difference of time depending upon the size of the furnace and the weight of metal contained in the crucible—the interior of the lower cylinder *e*, acquires a white heat. The progress of the operation can be watched by occasionally removing the stone peg in the trial hole of the furnace cylinder *e*. The heat very slowly ascends into the upper cylinder, and it never becomes so great in the upper as in the lower cylinder. The greatest fusing power of the furnace is confined within a vertical space of about six inches reckoning from the bottom. The power of flint pebbles to abstract heat from the gases which pass through this apparatus is quite remarkable. When about six inches of pebbles lie above the crucible, and the crucible and the pebbles about it have been white-hot for half an hour, the hand can be held over the top of the furnace, within a few inches of the pebbles, without inconvenience. It becomes wetted with the vapour which rises from the furnace, but feels only a moderate degree of heat.

This form of the furnace is attended by the inconvenience that you

cannot examine the condition of the matter contained in the crucible, to ascertain when the heat has been continued long enough. In cases where the fusion is performed repeatedly on the same weight of metal, this would be of no importance, because the power of the furnace is so steady and regular, that the time of firing which has been found to answer once will answer the same purpose again.

When it is supposed that the fusion of the metal submitted to trial is completed, the gas is first to be turned off, and then the supply of air stopped. You can either allow the furnace to remain intact till it is cold, or lift off the cylinders *e, e*, with tongs, and allow the hot stones to fall into the iron pan placed below the furnace to receive them. A few bricks should be laid between the pan and the table or stool on which it rests, if the latter is made of wood; because the heat given off by the pebbles is very great. The pebbles being raked away from the crucible, the contents of the latter can be examined.

Gas Furnace heated from below, and provided with a lifting apparatus, to afford access to the Crucible; exhibited in Section and in Perspective by figs. 432 and 433.

This modification of the furnace is contrived to afford the means of inspecting the contents of the crucible, without serious interruption to the process of ignition. The apparatus is shown in section by fig. 432, and in perspective by fig. 433. Besides the pieces that are similar to

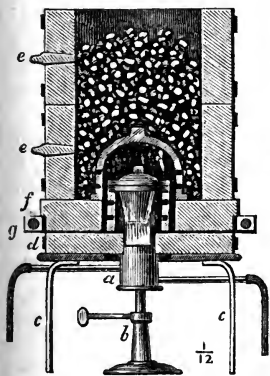

432.

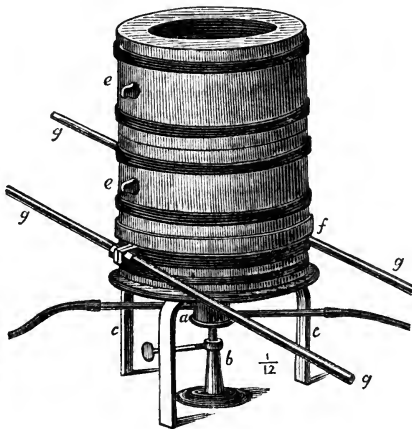

433.

those which form the other furnaces, this furnace has two additions, a *lifter* and a *dome*.

The *lifter*, represented by *f*, in figs. 432, 433, and separately by

fig. 434, is a plate of fire-clay, two inches thick, and having a central hole, *large enough* to go easily over the crucible jackets and crucibles represented by figs. 421 to 424, 427 and 428; and *small enough* to permit the plate to carry and lift up the *dome*, fig. 426, when of a sufficient size to cover the crucible. The lifter is bound with a ring of stout iron, and is screwed to two iron rods, *g, g*, of from half an inch

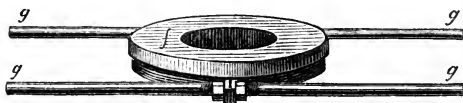

434.

to three-quarter inch in thickness, and three to four feet in length, according to the size and weight of the furnace to be lifted.

The packing of this variety of furnace is performed as follows: the clay plate *d*, and the lifter *f*, are placed upon the tripod-stand. The crucible jacket, fig. 423, or one similar, but of larger size, is placed upon the plate *d*. The crucible and its cover is then put into its place, and is covered with the dome, fig. 426, which must rest upon the lifter *f*, and must be of such a width as to clear the crucible easily when lifted. The internal height of the dome should be such as just to clear the top of the crucible cover. Consequently, where crucibles of different sizes are used, domes of different sizes are also necessary. Observe, distinctly, that the crucible and its support are to rest upon the plate *d*, and the dome upon the lifter *f*. The furnace cylinders *e, e*, are now to be superposed, and the space between the dome and the cylinders, and that above the dome, are to be filled with small pebbles as already directed. The gas may then be lighted, the blast of air set on, and the operation be allowed to proceed.

When the ignition has been continued as long as is considered necessary, or when you wish to inspect the contents of the crucible, the gas is to be turned off, the blast of air stopped, and two men, holding the bars *g, g*, are steadily to lift up the whole upper part of the furnace, namely, the lifter *f*, the two cylinders *e, e*, the dome, and the pebbles; leaving the clay plate *d*, with the crucible and its jacket, both at a white heat, standing clear in the middle. The cover of the crucible is then to be lifted, and the contents examined. If the fusion is not completed, the furnace is to be carefully lowered into its former position, the gas is to be turned on, and the blast renewed. This interruption of the process scarcely occupies a minute. I have already mentioned that, for the convenient inspection of the crucible at a white heat, it is necessary to look at it through a piece of dark-blue glass.

The figures of the gas-furnaces are drawn to scales, which show the relative proportions of the different parts. The absolute sizes of the

furnaces depend upon the amount of work required from them. The fusions described below were mostly made in a furnace of six inches internal diameter, a few in a furnace of four inches internal diameter, and one or two in a furnace of eight inches internal diameter; all of them with a gas-burner of sixteen holes, and a supply of gas obtained from a half-inch pipe. A large furnace on the plan of figs. 432, 433, and with an internal diameter of twelve inches, will demand a gas-burner of twenty-six holes, and a supply of gas from a pipe of nearly one inch in the bore.

Examples of Fusions effected by the Blast Gas Furnace.—The fusing points of certain metals have been fixed by Daniell at the following temperatures:—

Silver . . .	1873° F.		Copper . . .	1996° F.
Gold . . .	2016°		Cast-iron . .	2786°
Brass, with 25 per cent. of zinc, at 1750° F.				

All these metals melt readily in the gas furnace. Quantities of 3 lb. of copper or cast-iron can be completely fused in fifteen minutes in a six-inch furnace. Quantities of 8 or 10 lb. of copper or cast-iron can be completely fused into a homogeneous mass in a six-inch or eight-inch furnace within one hour, using a sixteen-hole burner, and a supply of gas from a half-inch pipe.

In a furnace of the same size I have fused 45 ounces of nickel, and in other experiments I have produced masses of wrought-iron weighing 18 ounces, 28 ounces, and 40 ounces. The piece of 18 ounces was perfectly fused. The piece of 40 ounces was not quite fused, the crucible having melted, and stopped the operation. I have also fused cobalt, and reduced it to the metallic state from the peroxide by ignition with charcoal. The time required for the fusion of these refractory metals is from one and a half to two hours.

Scraps of platinum can be fused into a porous mass, but not into a solid homogeneous bead. I have mentioned that thin platinum wires fuse readily in the free flame of the gas-jet produced by the burner fig. 415; but when the jet plays upon a quantity of the metal contained in a crucible the relations of power and effect are different.

When the metals to be melted are such as do not undergo oxidation, the method of action represented by fig. 430 is most convenient. In this manner gold can be readily melted, and by removing the gas-burner the melted metal can be stirred. When the action of oxygen is to be avoided, the crucible must have a cover, which in some cases should be securely luted to it.

Choice of Crucibles.—The experiments above referred to were made with coal gas at the ordinary pressure, and with a blast of cold atmospheric air. Greater effects can be produced by the use of oxygen gas, or of heated atmospheric air. But a difficulty stands in the way of the

use of these greater degrees of heat in the want of crucibles capable of enduring their action.

With cold atmospheric air, pure nickel and pure iron dissolve every kind of clay crucible, and it is therefore needless to heat the air or to prepare oxygen till a superior kind of crucible is obtainable. At present, these metals can only be melted in plumbago crucibles, which necessarily communicate to them more or less carbon.

Metals which melt at moderate degrees of heat, such as gold and copper, are easily fused either in clay crucibles, or in those of plumbago; the latter, be it remembered, being a mixture of graphite and clay. Metals in combination with carbon, such as cast iron, also melt readily in clay crucibles, without destroying them. But when such metals as iron, nickel, and cobalt, are freed from carbon, and brought into a state of purity, they acquire an extraordinary attraction for silica at a white heat, so that the metal and the silica readily run down into a very fusible silicate. Even when plumbago crucibles are used, the carbon burns away at some particular point, the metal then attacks the clay, bores a hole through the crucible, and finishes the operation. No kind of clay or porcelain will withstand the action of pure iron or nickel at a white heat. It is therefore impossible to effect any large fusions of these metals when they are free from carbon, or when they are heated in crucibles that are free from carbon.

Fusion of Metals in large quantities and Ignition of Objects of large size.—As the gas-burner, fig. 415, can be held in any required position it is possible to apply heat to large objects by using several gas-burners. Thus, a large crucible may be fixed in a square furnace, and gas-burner be applied below and on the four sides of the furnace; the space between the crucible and the walls of the furnace being filled with pebbles, to collect the heat and apply it to all parts of the crucible.

Muffle Furnace for Assaying, Roasting, &c.—A muffle, placed in an assay furnace, and built up with pebbles, can be heated either from above or from below by the blast gas-burner. The flame and product of combustion can be made to sweep through the muffle, whether going upwards or downwards. The *air* pipe and *gas* pipe attached to the gas-burner, fig. 415, must each be provided with a stopcock. When the front door of the muffle is opened to afford the opportunity for examining the cupels, the blast, if continued, would blow out the operator; but that occurrence is prevented by turning the stopcocks. When it is desired to oxidise the substances in the muffle the furnace is first brought up to a sufficient temperature, and then the gas is turned off, but the blast of air is continued. The air passing through the hot pebbles enters the muffle at a high temperature, and is not exhausted of oxygen, because there is no carbonaceous matter present among the pebbles when the gas is turned off. The pure and highly heated air is consequently in a proper condition for oxidising

metals that are already raised to a red heat in the muffle. The same apparatus is useful where substances require to be roasted in the presence of air, in order to oxidise and expel some volatile ingredient. We have in this process an effectual means of using hot air to aid the process of cupellation.

Distillation per descensum.—Suppose a stoneware bottle with a long neck to be fitted with a stoneware tube, passing nearly to the bottom of the bottle, and projecting some inches beyond its mouth. Suppose this bottle to be half filled with metallic zinc, and then to be fixed upside down in the furnace, fig. 430, with the tube projecting downwards through the hole in the plate *d*, and nearly dipping into a vessel of water. The furnace being packed with pebbles, and the heat applied at the top, the distillation of zinc *per descensum* then takes place.

Miscellaneous Uses of the Blast Gas Furnace.—1. The preparation of chemical substances by the projection of mixtures into a crucible kept at a red or a white heat. 2. For melting silver, gold, copper, cast iron, brass, bronze, nickel-silver, &c., either for making small castings, or ingots. 3. For experiments on glass; every description of which it is able to fuse. 4. For experiments on enamels, coloured glasses, and artificial gems. 5. For experiments on metallic alloys. 6. For the fusion of steel. 7. For the use of dentists, in the preparation of mineral artificial teeth. 8. For the assay of ores of silver, copper, lead, tin, iron, and other metals. 9. For all purposes of ignition, combustion, fusion, or dry distillation, at a red heat, or a white heat, where it is desirable to produce those temperatures promptly, certainly, steadily, conveniently, and cheaply.

Exhibition of Coloured Flames.—When the gas-burner, fig. 415, is supplied with gas and air, and is inflamed in the open air, so as to produce a clear blue flame of 3 inches high, and above it a flickering, nearly colourless flame of 12 inches high, brilliant colours may be given to this flame by the introduction of concentrated solutions of certain salts. A ball of pumice-stone, 2 inches in diameter, fastened to a stout iron wire, is dipped into the saline solution, and while wet is plunged into the flame, upon which the whole flame becomes coloured. Solutions of the following salts may be used for these experiments:—

1. *Chloride of Strontium*, gives a brilliant crimson flame. 2. *Chloride of Calcium*, a reddish-orange flame. 3. *Chloride of Sodium*, brilliant yellow. 4. *Chloride of Copper*, bluish-green. If the flame is touched on one side with the copper solution, and on the other with the strontium solution, half the flame is green and half crimson. The colours and reflections of these flames are necessarily most brilliant in a dark room. A remarkable effect is produced by the yellow soda flame. It is reflected from the human countenance with a ghastly blackness. In order to prevent the obstruction of the jet, and the mixture of colours in the flames, by the falling of drops of the saline

solutions into the pipes of the jet, it is advisable to lay the jet on its side, which gives the coloured flames a horizontal direction.

Repair of the Gas Furnace.—When the clay cylinders become warped or chipped, so as to allow the gases to escape at the joints laterally, they must be luted for each operation by applying a little wet fire-clay by means of a spatula. This can be best done during the ignition, because the light then shows where the clay is required. After the operation, the fragments of clay should be scraped away, and not be allowed to mix with the flints, because when they get into the body of the furnace, they melt and spoil the draught. When only a moderate heat is required, this luting is unnecessary.

As the heat of the furnace gradually splits up the pebbles, all pieces under $\frac{1}{4}$ inch diameter, should from time to time be sifted away, otherwise they stop the passage of the gases.

SPIRIT LAMPS.

In many localities, the choice of a fuel is not left to the chemist. He uses coal gas if he can get it, and if not, he resorts to spirits or to charcoal. I shall describe a few varieties of lamps suitable for use with spirits. The theory of the combustion of spirits I have explained sufficiently. The spirits commonly used as fuel for lamps are, alcohol = $\text{H}_2\text{C}^2\text{H}^6\text{O}$, wood spirit = $\text{H}_2\text{CH}^3\text{O}$, and turpentine = $\text{C}^8\text{H}^8, \text{C}^9\text{H}^7$, all of which, by combustion with oxygen, necessarily produce carbonic acid and water. We are to consider here chiefly the forms of the apparatus.

The common spirit lamp is shown by fig. 20, page 49. Another form is exhibited by fig. 435. This is a glass lamp, with brass fittings, including a rack for raising and lowering the wick, to regulate the heat as required.

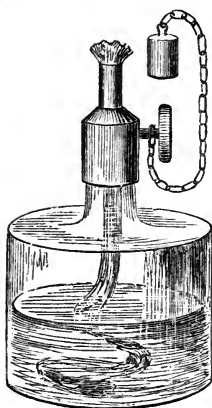

The Russian Spirit Lamp.—This lamp is represented in section by fig. 436. It is usually made about six times the size of the figure. The material is brass, hard soldered. A quantity of alcohol, measured in the cover k , is put into the enclosed space by the tube l , which is then closed by a cork. A similar measure of alcohol is put into the open space c , and this is set on fire. The heat boils the spirit contained in the enclosed space, and the vapour produced rushes through the curved blowpipe d, f , takes fire at f , and produces a powerful bulky flame. The ob-

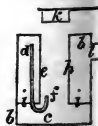

436.

ject to be heated is placed in the position shown by the cover marked

and is retained there by means of a triangle support. Of course this apparatus is suited only for operations which require a powerful heat for a few minutes.

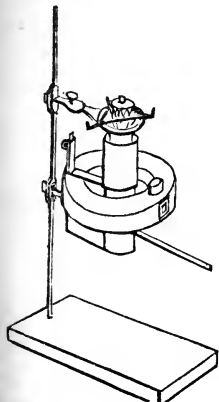

437.

I have represented at *g*, in fig. 146, page 183, one of the common forms of the Argand spirit lamp. Another representation of it is given in fig. 437. This lamp differs in principle from an ordinary Argand oil lamp only in the manner in which the spirit is conveyed from the circular spirit-holder *a*, to the wick-holder *b*, represented in fig. 438. The conveyance is by a tube *k*, which passes from the bottom of the spirit-holder to the bottom of the wick-holder; the wick-holder being detached from the spirit-holder either by spaces *t, t*, or by division plates. If alcohol is burnt



438.

in a common Argand oil lamp, in which there is no arrangement of this sort, the mixture of spirit and air which forms above the liquor in the spirit-holder, sometimes takes fire with an explosion, which does mischief.

Fig. 439 shows only a different method of mounting an Argand spirit lamp. *a* is a pierced iron plate, and *b* is a brass plate, fitted to

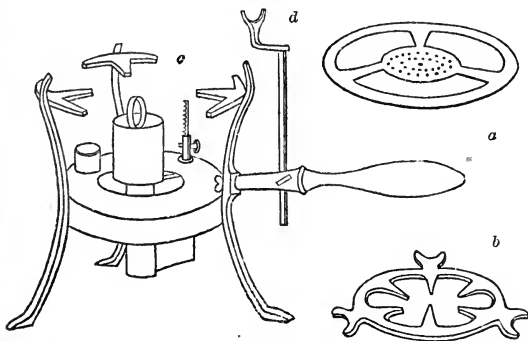

439.

the tripod *c*; *d* is a moveable support for sustaining the handles of retorts, necks of retorts, &c., when placed over the lamp. Fig. 441 presents another method of mounting such a lamp. Fig. 439 is the Berlin mode, and 441 is the Paris mode.

In fig. 440, we have a representation of a lamp in which the wick-holder and the spirit-holder are wider apart than in lamps of the form

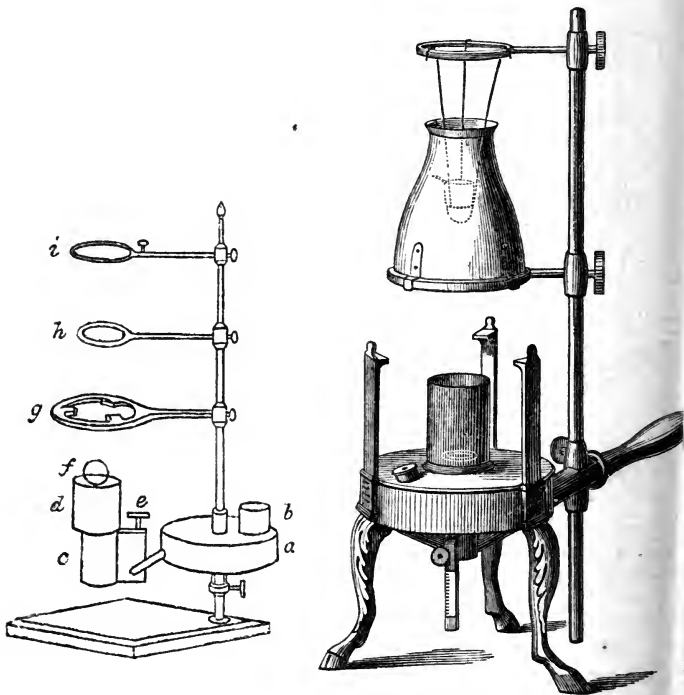

440.

441.

previously depicted. The effect of this arrangement is to keep the spirit from boiling in the spirit-holder, and thereby becoming unmanageable and wasteful. This arrangement, however, is not very material; for lamps of the other form, if well made, kept clean, and properly attended to, rarely become troublesome.

Deville's Turpentine Lamp. — Professor Sainte-Claire Deville contrived a lamp, in which the combustion of spirit of turpentine is effected with the assistance of a blast of atmospheric air; and the result is the production of a high degree of heat. The apparatus is represented by figures 442 and 443, at about one-fifth part of the actual size. The spirit of turpentine is put into the bottle *a*, from which it flows in quantities regulated by the stopcock placed on the pipe which conveys it to the lamp *c*.

The internal arrangements of this lamp are shown by the section given in fig. 443. When the lamp is in action, the efflux of the tur-

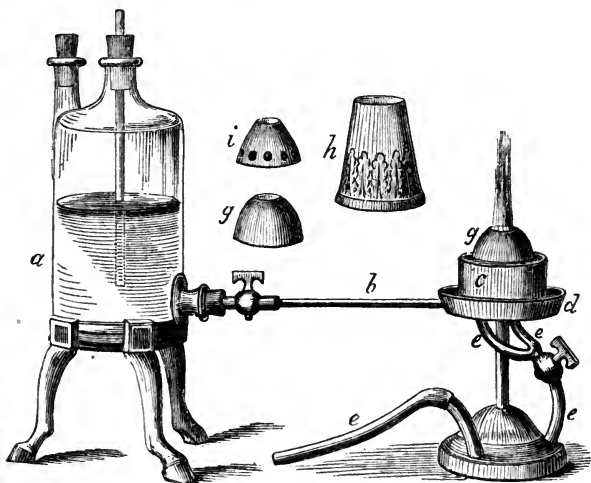

442.

pentine is regulated by the position of the vertical tube fixed in the middle of the turpentine bottle, and intended to admit atmospheric air. This air-tube must be so fixed that its lower end shall be exactly one-fifth of an inch below the level of the small holes shown in the centre of fig. 443. The establishment of this level, and the retention of the whole apparatus in a steady horizontal position, is essential to its proper working. If this is not attended to, either the flame expires, or the turpentine flows over and burns with a voluminous flame, which is dangerous, and a smoke and stink which are most offensive. The proper adjustment of the apparatus being accomplished, a suitable supply of turpentine being secured to the lamp *c*, and the stopcock in the pipe *b* being partially opened, the operation may proceed. Water is poured into the tray *d*, round the lamp, and it is made to boil by the external application of a spirit lamp, until it heats the turpentine within the lamp *c*, and converts a quantity of it into vapour. The stopcock on the pipe *e* may then be opened, and air be blown into the

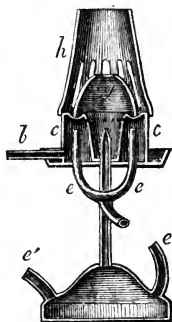

443.

the lamp. The air should come from a blowing-machine sufficiently powerful to keep up a constant blast of air under a pressure equal to that of a column of mercury three inches high.

The vapour issuing from the cone *g*, should then be inflamed, and when it burns steadily the stopcock on the pipe *b* may be opened to the full, and the whole force of the blowing-machine may be exerted. A few careful trials are necessary to ascertain the correctness of the levels, and to determine the extent to which the two stopcocks should be opened.

The air and vapour of turpentine are mixed within the body of the lamp *c*. The mixture is forced by the blast of air through the small holes towards the centre of the lamp, under the dome *g*, and is there inflamed, and at the same time acted upon by air from the blowpipe in the centre, rising from the air reservoir at the bottom, which is fed by the blastpipe *e*. This blowpipe should have a bore of one-twelfth of an inch, but it should vary with the size of the crucible that is to be heated.

The copper domes *g*, *h*, *i*, serve to regulate the mode of applying the heat; and the larger of them, *h*, which is three inches high, is that on which crucibles are suspended by means of a triangle of platinum wire. The perforations in *h*, serve to admit atmospheric air, when the blast from the blowing-machine is not sufficient for the complete combustion of the vapour of turpentine. The upper openings of the domes *g*, and *i*, are three quarters of an inch across. The flame of this lamp is extinguished by turning off the two stopcocks; first that which is on the pipe from the turpentine, and then that on the pipe from the blowing machine. The tray *d*, should be kept full of water during an ignition, in order to prevent the too rapid boiling of the turpentine in the lamp *c*.

Blast Spirit Lamp.—The spirit lamp shown by fig. 444 is adapted for use with a mixture of alcohol and spirit of turpentine, and when acted on by a good blast of air it has considerable power, though not so much as that possessed by Deville's turpentine lamp. The spirit holder, *a*, *b*, and its vertical regulating air-pipe, resemble those of Deville's lamp; but it differs from that lamp by being used with an Argand wick, and by having the air from the blowing-machine blow up into the middle of the Argand flame. This air is blown in by the tube *d*, which is capable of being raised or depressed and of being altered at the mouth by blowpipe jets having orifices of different size to suit the varying supply of spirit and the changeful height of the Argand wick. The crucible that is to be heated is suspended by a triangle of platinum wire on the notched cone inverted over the lamp.

Deville's Chemical Forge.—This furnace is to be used with good coke or cinder of good coal, when the highest degrees of heat are to be obtained. It is, however, fitted to serve a variety of chemical pro-

cesses where gas is not at command. It consists of a blowing-machine and several adjuncts for miscellaneous operations. The whole of the

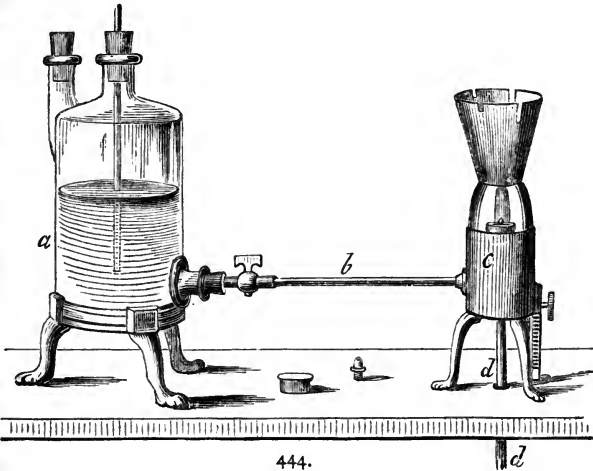

444.

fittings are represented by fig. 445. The blowing-machine is represented by letter a. It is worked by the handle marked b, but some-

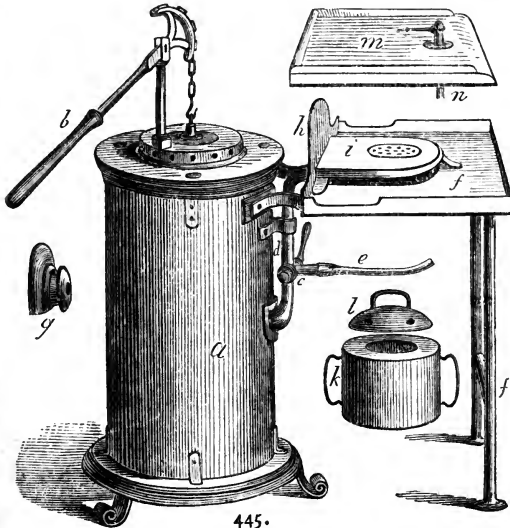

445.

times by a chain or cord attached to a foot-board like that represented in fig. 446. The head of the blowing-machine turns round horizontally, so that the handle, *b*, can be put into any convenient position, to suit the operation or the locality. The blast of air passes from the blowing-machine to the three-way stopcock *c*, by which it can be directed either upwards through the tube *d*, or sideways through the tube *e*. Letter *f* represents an iron table, in which there is a cavity which qualifies it to act as a smith's forge. This cavity is under the plate *i*, which must be removed when the apparatus is to be used as a forge, and the solid iron nozzle, *g*, must be fixed in its proper place. The iron table, *f*, is screwed at the back to the blowing-machine, and is supported in front by two iron legs, also marked *f*. Letter *h* represents a back to which the nozzle *g* can be fastened.

When the apparatus is to be used as a blast furnace, the nozzle *g* is put aside, the plate *i* is fixed, as shown in the figure, including the round plate perforated with holes, which is placed in a cavity over the blast of air. The fire-clay cylinder, *k*, is then placed on the platform, *i*, directly over the perforated plate, and in this cylinder crucible operations are to be performed. The crucible is placed on the middle of the perforated plate, a little raised by a fire-clay foot, and is surrounded and covered by chopped coke or cinders free from clinkers, of the size of nuts. The greatest heat in this furnace commences at about an inch from the perforated bottom plate, and ends at about 3 inches from the plate; but within that range it is very intense. Above 3 inches, the heat diminishes with rapidity, in consequence of the conversion in the upper part of the furnace of carbonic acid into carbonic oxide. According to M. Deville, the production of carbonic oxide takes place to such an extent that it can produce a flame of 6 feet high. Letter *l* in fig. 445 represents a cover which serves, to some extent, to prevent the scattering of the fuel by the blast of air.

The heat produced by this furnace is so great that it brings into action the difficulty which arises in the use of the blast gas furnace, namely, the want of crucibles sufficiently refractory to endure its power. M. Deville recommends the formation of crucibles of gas-coke, quicklime, and pure alumina. These substances may answer for refined experiments in the hands of a philosopher, but they are unsuitable for commercial operations, or for the use of students of chemistry. Crucibles of gas-coke of any considerable size are so difficult to procure that they become excessively dear. Quicklime is, in many situations, not easily procurable, and crucibles made of it must be used immediately, or they fall to powder. Alumina is not only expensive, but it cannot be formed into sound crucibles without great difficulty, and with so many failures, as to make the cost very great. It follows, therefore, that improvements in crucibles are required before the power of existing furnaces can be fairly tested.

Letter *m*, in fig. 445, is a blowpipe table (for glass-blowing a

similar purposes), which can be adapted to the blowing-machine instead of the forge or blast furnace. When adjusted to it, the blowpipe *n* is connected with the air-tube *e*, and the stopcock *c* is reversed to suit this new arrangement. The blast of air is in this case to be put into action by a string or chain fastened to the handle *b*, and connected with a foot-board fastened to the ground, on the plan of the one represented in the next figure.

The blowing-machine of this apparatus, if it gives a sufficient and continuous blast, can be used with the blast gas furnace.

GLASS-BLOWING APPARATUS.

I conclude this section with a representation of a glass-blowing apparatus, which, after the foregoing description of a blowing-machine, requires no particular notice. It gives a steady blast of air, which is to be used with an oil-lamp or a gas-burner. It can also be used as a blowing-machine in all cases where its blast is sufficiently powerful.

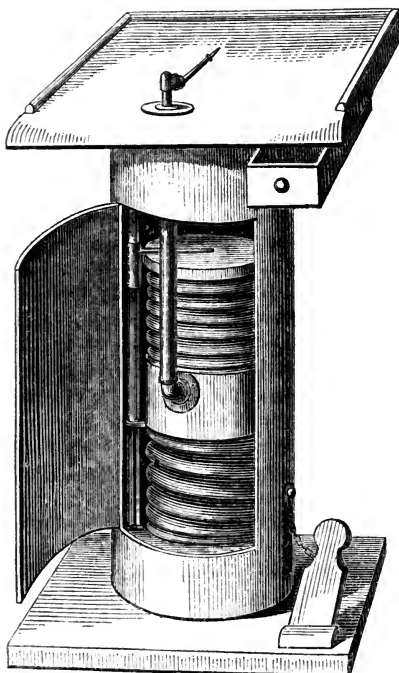

5. SULPHUR.

Symbol, S; Equivalent, 16; Specific gravity of gas, 96; Atomic measure when isolated, 1 volume. According to Bineau, the specific gravity of the vapour of sulphur at 1800° F. is 32, in which case its atomic measure will be half a volume. Atomic measure when acting as an acid radical in gaseous salts, 0; Condensing power on other radicals, with which it combines to form gases, 0.

Occurrence in nature. See page 12.

Properties.—At the ordinary temperature of the atmosphere, sulphur or brimstone is a solid substance, exhibiting a shelly fracture and a yellow colour. When it is obtained in crystals by proper treatment of a solution of sulphur, or when found in the vicinity of burning mountains, it is transparent; but when it has been submitted to fusion, it is opaque. When obtained in the state of powder, and particularly when produced in an aqueous solution, its colour is nearly white. It is brittle. Its specific gravity is 1.98. It is insoluble in water, and not poisonous. It burns in the air with a blue flame, and diffuses a peculiar odour, which is due to the presence of sulphurous acid gas. It fuses at a temperature rather higher than that of boiling water, about 230° F., and at 270° F. it forms a thin yellow fluid, while at a still higher temperature, about 320° F., it becomes thick and gluey, and acquires a brown colour. If the thick fluid is put into water, it produces a brown tenacious mass, which remains soft for some time, but ultimately becomes solid, brittle, and yellow. If the melted sulphur is raised to a very high degree of heat, about 800° F., in closed vessels, it boils, and is converted into a deep orange-coloured gas, which appears to the eye like peroxide of nitrogen. The volume of this gas is 500 times greater than that of the solid sulphur. Its specific gravity and atomic volume are stated above. If this gas is inflamed in the air, it burns, like sulphur, with a blue flame and a smell of sulphurous acid. It is in consequence of the production of this peculiar odour by combustion that the presence of sulphur is very easy of detection.

When sulphur is boiled with nitric acid in a flask, it dissolves, and produces oil of vitriol. Nitric acid of ordinary strength effects this oxidation with difficulty; but fuming nitric acid is capable of dissolving sulphur with facility. Hydrochloric acid does not dissolve sulphur. Aqua regia, or a mixture of nitric acid and hydrochloric acid, converts sulphur into oil of vitriol more readily than either of the acids alone. Chlorine gas led over powdered sulphur produces chloride of sulphur. A solution of pure potash dissolves sulphur at a boiling heat, and the

resulting solution contains sulphide of potassium and the salt termed hyposulphite of potash.

EXPERIMENTS WITH SULPHUR.

1. *Fusion and Crystallisation.*—In a small glass capsule, exposed to a gentle heat over a spirit-lamp, put a small lump of sulphur. When that is melted add another lump, and so on till the glass is nearly full of melted sulphur. Take care to keep the temperature as low as possible, consistent with the fusion of the sulphur, which at 230° F. will form a limpid, citron-coloured liquid. Remove the lamp, and observe the cooling of the sulphur. Fine crystals will be seen to shoot from the sides and stretch towards the centre. When these increase, so as to seem to be ready to cover the whole surface as with a net, the glass may be suddenly inverted and the residual liquid be drained out. The capsule may be taken hold of by the fingers for this purpose. If the ejection of the fluid sulphur is effected at the proper moment, the glass will contain an elegant collection of slender, delicate, transparent needles of sulphur. The process may be repeated till a good product is obtained.



447.

2. Melt about a pound of sulphur in a crucible at the lowest temperature that will insure fusion; remove the crucible from the fire, and let it cool till a crust is formed on the surface. Prick a hole in the crust, invert the crucible, and let the residue of the liquid sulphur run out. When the crucible is cold, break it to get at the mass of crystals, which must be seen across, as shown in the figure.

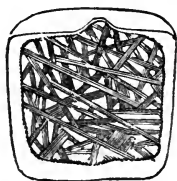

448.

3. *Fusion at a high temperature.*—Melt sulphur in a porcelain capsule over a spirit-lamp or gas-light, and gradually increase the heat, until the thin lemon-coloured liquor turns thick, and changes its colour, passing from yellow to red, brown, and almost to black. At this point lift the capsule and pour the sulphur from a height into water contained in a pan. The brown sulphur will form a soft tough mass, which possesses great ductility, so that it can be pulled into strings, and which does not become hard and brittle, or resume its yellow colour for some days. If melted sulphur in the state of a thin yellow liquor is poured into water, it immediately forms a yellow brittle solid.

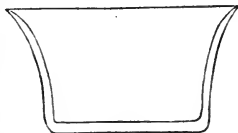

448a.

4. *Combustibility of Sulphur*.—Heat a fragment of sulphur upon a piece of broken glass or china, or in a capsule. It first melts and afterwards takes fire, burning with a blue flame, and the well-known suffocating odour of burning brimstone. This odour results from the diffusion of sulphurous acid gas. Sulphur burnt on charcoal before the blowpipe, or at the flame of a candle, or in an open glass tube, produces the same effect. Sulphur burns with a brilliant flame in oxygen gas. See page 184.

5. *Volatility of Sulphur*.—Heat a small piece of sulphur in a tube of hard glass, closed at one end, and held over the flame of a spirit-lamp at an angle of about 45° . The upper end of the tube may be partly closed by a square cork. See page 57. The sulphur at first melts, and then rises in red vapour, which condenses in a fine powder on the upper cooler part of the tube. This powder is *flour of brimstone*, or sublimed sulphur.

6. *Distillation of Sulphur*.—Sulphur can be purified from fixed substances by distillation in close vessels. If the sulphur is pure it leaves

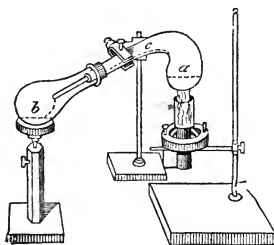

449.

no residue. A small quantity of it is fused in a retort, *a*, by the heat of a spirit-lamp. The sulphur soon rises in the state of gas, which, being coloured, is visible. In the cool part of the neck of the retort, *c*, this gas becomes condensed, that is to say, where the temperature is reduced below 230° F. It then forms a yellow crystalline powder (sublimed sulphur). On continuing the distillation, the neck of the retort gradually

becomes warm, upon which the powder melts, and as soon as it is sufficiently fluid, it runs down the neck of the retort into the receiver, *b*. The whole of the sulphur can be thus driven out of the retort into the receiver. If it contained clay, sand, or other mineral impurities not volatilisable, these remain behind in the retort. It is by such a process as this that most of the sulphur of commerce is prepared from mineralised sulphur procured in Sicily and other countries. Sulphur is also separated by heat from some metallic sulphides, as that of iron. Thus $\text{FeS}^2 = \text{FeS} + \text{S}$. The *roll* sulphur is prepared by running fused sulphur into moulds. The sublimed sulphur is prepared in quantities, by distilling sulphur in a current of warm air, but at a temperature too low for combustion. As the air cools, the sulphur is deposited from it in powder, just as gaseous water falls from cold air in the form of snow.

7. *Precipitated Sulphur*.—Boil powdered sulphur in a solution of caustic potash. It produces a transparent brown liquor which holds sulphur in solution. If the clear liquor is mixed with diluted sulphuric acid, the sulphur is precipitated in the form of a greyish-white powder.

8. *Crystallisation of Sulphur from a solution.*—Sulphur dissolves in hot oil of turpentine, and more readily in sulphide of carbon. The last-named fluid is extremely volatile, and readily flies off in vapour when exposed to the air in an open vessel. Hence a solution of sulphur in sulphide of carbon very readily gives crystals of sulphur. The form of the crystals of sulphur obtained at volcanoes is the same as the form of those that are obtained by crystallisation from solutions and by slow sublimations, being a rhombic octahedron; but the form of the crystals of sulphur produced by fusion is different, and belongs even to a different system of crystallisation.

9. *Imitation of Medals and Seals in Sulphur.*—A mould is first made in plaster of Paris. The medal to be copied is surrounded by a rim of paper, and is slightly oiled over its whole surface. A thin mixture of plaster of Paris and water is poured over it, and allowed time to consolidate. This forms the mould, which is separated from the medal when quite solid, and is well dried by exposure to a moderate heat. It is to be slightly oiled, and a band or rim of paper is fastened round it. Sulphur is then fused into the brown tough state, and when liquid, is poured into the mould. When it is cold, the impression will resemble that of the original medal. It may be bronzed by rubbing over it a little plumbago.

10. *Spontaneous Combustion of Metals in Gaseous Sulphur.*—Sulphur is to be boiled in a long test-tube of hard glass, one inch in width, till the tube is full of gaseous sulphur. The tube may be supported as shown in pages 48 or 76. Or instead of using a tube, the sulphur may be boiled in a vessel of hard glass, similar to a Florence flask, as shown in fig. 450.—1. Nickel, in fine powder, poured into it, spontaneously inflames.—2. Thin films of copper do so also.—3. A bit of potassium, fixed on a thin iron wire, inflames and sets fire to the iron, which does not inflame alone.—4. A thin plate of copper becomes red-hot when held in gaseous sulphur.—5. If thin iron wire is coiled round such a plate of copper, and the two metals plunged together into the gaseous sulphur, first the copper becomes red-hot, then the iron takes fire and burns with a brilliant light, and finally the plate of copper melts.—6. Narrow slips of tinfoil inflame.—7. Pretty thick slips of sheet-lead inflame and fall down in drops of sulphide of lead.

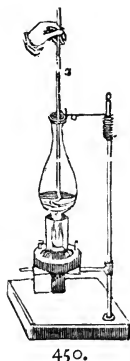

When pieces of iron and copper wire cannot be procured sufficiently thin for the above experiments, the action may be promoted in the following manner. The tube is to be chosen pretty long, and to be placed almost horizontally; the sulphur put at the bottom and the twisted wire near the middle of it. That part of the tube is first to be

heated where the metal lies, and then another spirit-lamp is to be used to boil the sulphur, the vapour of which acts more readily when the metal is thus previously heated. The compounds produced by these combustions are metallic sulphides.

OXIDES OF SULPHUR.—The compounds which contain sulphur and oxygen only are these three:—

SO. *Sulphate*, or Sulphurous acid.

S,SO³. *Sulpha sulphite*, or Anhydrous Sulphuric acid.

S,SO. *Sulpha sulphate*.

Of these three compounds, the first and second can be obtained in an isolated state. The third only in combination with oxysulphur salts.

SULPHUROUS ACID.

Formula, SO; *Equivalent*, 32; *Specific gravity of gas*, 32; *Atomic measure*, 1 volume; *Systematic name*, Sulphate.

Preparation of Sulphurous Acid Gas.—I. Take equal weights of metallic mercury and concentrated sulphuric acid; pour them into a retort or flask, and apply the heat of a lamp or small furnace. This gas is absorbable by water, and cannot be collected in jars placed over the water-trough. It must, therefore, be collected over mercury, or else by the method of displacement described at page 320. But, in this case, as the gas is very much heavier than common air, it must be collected in a receiver placed with the mouth uppermost, fig. 452. Let each bottle of gas be corked and secured with soft cement as soon as it is full.

Theory:—

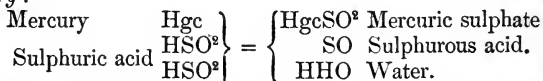
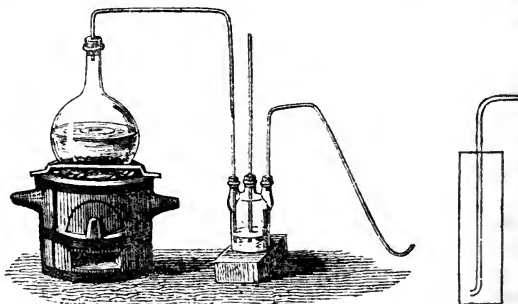

Fig. 451 represents the arrangement of apparatus used in this experiment. As the gas carries with it a little sulphuric acid, it



451.

452.

requires to be washed in water before it is collected. If it is to be collected in a dry state, it must then be passed through a chloride of calcium tube, and ultimately be collected over mercury by such an apparatus as is shown by fig. 311, page 319. Fig. 452 shows the method of collecting this gas by *displacement*, the delivery-tube passing down to the bottom of the jar. To ascertain when the jar is full of gas, moistened coloured test-papers are held to the mouth of the jar. Sulphurous acid bleaches many vegetable colours, such as those of brazil and logwood; it first reddens litmus.

2. Sulphurous acid gas may also be prepared in the above manner with copper turnings instead of mercury.

Theory :—

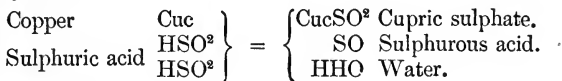

3. Mix intimately three parts of black oxide of copper with one part of sulphur, put the mixture into a narrow glass tube, and put above it half its bulk of oxide of copper. First heat the latter red-hot, and then heat the mixture, which will give out sulphurous acid gas. It may be passed through a tube containing chloride of calcium, or through oil of vitriol contained in a V-tube. The gas so prepared is pure.

Theory :—

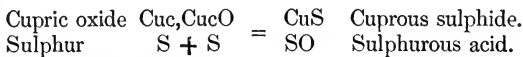

4. Mix three parts of black oxide of manganese with one part of sulphur, both in fine powder. Heat the mixture in a little retort, and wash the disengaged gas in a small quantity of water. It is then pure sulphurous acid.

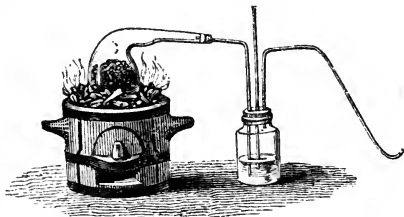

453.

Theory :—

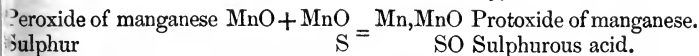

Properties of Sulphurous Acid Gas.—This compound gas is colourless, incombustible, incapable of supporting combustion, and possessed of a peculiar suffocating odour; it reddens wet litmus paper, and bleaches many vegetable and animal colours (straw, nuts, wood, jelly, sponge, silk, wool, &c.) The specific gravity of sulphurous acid gas is 3.2. Its atomic volume is 1. Hence it contains equal weights of oxygen and sulphur. By pressure or exposure to the temperature of 4° F.; it is made to assume the form of a liquid, which boils at 14° F., and pro-

duces great cold by its evaporation. It is not decomposable by heat. It combines directly with brown oxide of lead and produces white sulphate of lead. $PbO + SO = PbO + SO = PbSO^2$. Sulphurous acid dissolves without decomposition in water, and the solution possesses the odour and many of the properties of the gas. This solution is converted into sulphuric acid if long exposed to the air.

Experiments with Sulphurous Acid Gas.—1. If a lighted candle is let down into a jar of this gas, it is immediately extinguished. When the gas is breathed, even when largely diluted with common air, it excites violent coughing. When a chimney is on fire, sulphur is sometimes put on the fire below, to throw this incombustible gas up into the chimney to put out the fire.

2. Sulphurous acid gas bleaches a great variety of vegetable colours, sometimes first turning them red. Try litmus paper; also tincture of cabbage, or logwood. Its solution in water produces the same effects.

3. A red rose loses its colour when dipped in a solution of sulphurous acid. The red colour is restored by dipping it into diluted sulphuric acid.

4. This gas is rapidly absorbed by water. If a bottle of cold water saturated with this gas, is plunged into a basin of hot water and uncorked, an infinite number of small bubbles will be instantaneously extricated, and the water in the bottle will appear to boil.

The great use of sulphurous acid in the arts is to bleach animal substances (woollens), the use of chlorine being restricted to the bleaching of cotton goods.

Condensation of dry Sulphurous Acid Gas to the liquid state.—Sulphurous acid gas can be condensed to the liquid state under the ordinary pressure of the atmosphere, if it be reduced by a freezing mixture to the temperature of 4° F. To effect this condensation, the

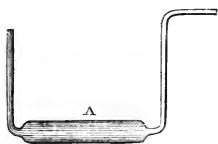

454.

gas, prepared in a pure and dry state, to be passed through a tube of the form fig. 454, immersed in a freezing mixture consisting of pounded ice and common salt, or better, of pounded ice and crystals of chloride of calcium. It can also be collected by means of the apparatus recommended at page 527, fig. 396, for the condensation of gaseous cyanogen.

The liquid thus produced is extremely volatile in the open air, because at 60° F. it requires a pressure of two atmospheres to keep it in the liquid state. If applied to cotton wool wrapped about the bulb of a spirit thermometer, it reduces the temperature down to -40° -50° F.

Preparation of solution of Sulphurous Acid in water, or in solutions of Alkalies (Sulphites).—1. The sulphurous acid gas for this purpose may

be prepared by the following easy and economical process:—We have seen that sulphur burnt in atmospheric air produces sulphurous acid. By the assistance of the apparatus shown in the annexed figure, the acid so produced may be collected and applied to use. *a* is a glass funnel, *b* a metallic cup, such as was described at fig. 150, page 185, *d* a V-tube, *f g* a water-bottle, *c e* connectors, *q p* a tube support. When the water runs from the stopcock *g*, air passes through the apparatus in the direction of the arrow, from *a* into *f*, and therefore passes through any liquor put into the V-tube at *d*. If the cup on the support *b* is filled with burning sulphur, the products of the combustion are drawn with the atmospheric air, through the V-tube, and the sulphurous acid is absorbed by the solution put into the bend of the V-tube, whether it be merely water or a solution of an alkali.

2). Instead of the pieces of apparatus *a b c* it is better to connect the tube *d* with a piece of stoneware or porcelain tube placed horizontally, and to put the sulphur into

the end of this tube, with a lamp placed immediately below, to keep up the combustion. In this manner sulphurous acid can be conveniently prepared in any quantity.

Experiments.—Pass, in this manner, sulphurous acid through a solution of cabbage, which is first reddened and then bleached; or through a solution of bichromate of potash, the yellow colour of which turns to green, owing to the reduction of the chromic acid to oxide of chromium; or through a solution of carbonate of soda, which produces sulphite of soda. See the article on “SULPHITES.”

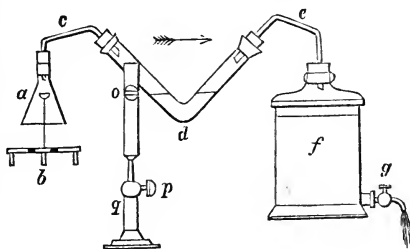

455.

ANHYDROUS SULPHURIC ACID. SULPHURIC ANHYDRIDE.

Formula, S, SO^3 ; *Atomic weight*, 80; *Specific gravity of its gas*, 40; *Atomic measure*, 2 volumes; *Systematic name*, Sulpha sulphite.

Preparation—I. By distilling fuming Nordhausen sulphuric acid, at the lowest temperature at which that acid boils, and collecting the product in a receiver cooled with ice. When the boiling ceases, and the conducting-tube becomes hot, the distillation is stopped. What remains in the retort is oil of vitriol.

Theory:—

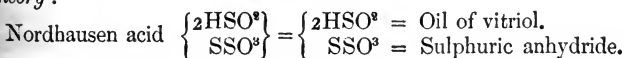

2. It can also be prepared by distilling at a high temperature the bisulphate of soda that has been previously heated to dull redness, to deprive it of all the water which it can yield. Neutral sulphate of soda remains in the retort.

Theory of the Preparation of dried Bisulphate of Soda :—

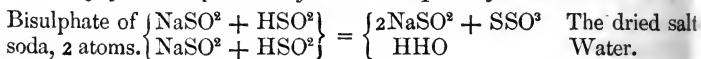

Theory of the Decomposition of the Bisulphate of Soda :—

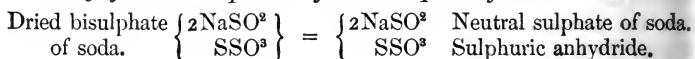

According to this view, the fuming sulphuric acid and the dried bisulphate of soda have the same equivalent composition. The theory of the anhydrides has been given at page 295.

The similarity in constitution between the Nordhausen acid and the dried bisulphate of soda demands especial attention. The two compounds are :—



This constitution is very common with compound salts of such acids and are subject to produce anhydrides. Thus, I have shown at page 44 that acetates exist which have this constitution :—

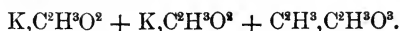

It is also the form of the salts usually called bichromates :—



Properties.—The sulphuric anhydride is not an acid. It forms white silky, fibrous crystals, which are tough, ductile, and can be moulded by the fingers without burning them. When thrown into water, it hisses like a red-hot iron, and produces much heat. Double decomposition takes place, and hydrated sulphuric acid is produced :—

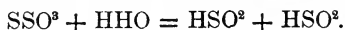

The anhydride melts at 65° F., and boils at 110° F., producing colourless gas.

SULPHA SULPHATE.

The Anhydrous Acid Sulpha sulphate = S,SO, corresponds to the Hydrated Acid Hydra sulphate = H,SO.

I have explained the relation that exists between the hydrated and the anhydrous sulphuric acids. I have shown that these are both

be considered as salts, and that the latter is produced by the decomposition of two atoms of the former :—



Precisely the same relationship exists between the hydrated acid H,SO and the anhydride S,SO ; for

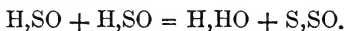

This compound, which I may call **SULPHA SULPHATE**, is of great importance for the elucidation of the salts of the polythionic acids, but it is unknown in the free state, and we can only infer its existence from the composition and the properties of the salts of which it is a component. But supposing that we could isolate it, we should have a salt on the model of water, in which S would be an unoxidised positive radical, and SO an oxidised negative radical, together = S,SO .

The anhydride S,SO exists in the salts that are called anhydrous hyposulphites, just as the anhydride S,SO^3 exists in the fuming sulphuric acid and in other equivalent salts. The name pentathionic acid, applied to the compound H,SO depends upon the unproveable assumption, that the composition of the acid is $\text{H}^5\text{S}^5\text{O}^5$.

OXIDISED SULPHUR SALTS.

In my treatise on the Radical Theory, I have discussed the constitution of the oxysulphur salts at considerable length. In this place I can only notice the most important of the series.

In the following formulæ, M signifies a basic radical, either hydrogen or a metal. In some cases only the hydrogen salts are known. In some cases only the metallic salts.

H = 1. S = 16. O = 16.		Usual Names.
1.	$\text{HSO}^2 = \text{HO} + \text{SO}$	Sulphates.
2.	$\text{HSO} = \text{H} + \text{SO}$	Pentathionates.
3.	$\left\{ \begin{array}{l} \text{MSO}^2 \\ \text{HSO} \end{array} \right\} = \left\{ \begin{array}{l} \text{MO} + \text{SO} \\ \text{H} + \text{SO} \end{array} \right\}$	Sulphites, = $\text{HM},\text{S}^2\text{O}^3$.
4.	$\left\{ \begin{array}{l} \text{HSO} \\ \text{MSO} \end{array} \right\} = \left\{ \begin{array}{l} \text{H} + \text{SO} \\ \text{M} + \text{SO} \end{array} \right\}$	Hyposulphites, = $\text{HM},\text{S}^2\text{O}^2$.
5.	$\left\{ \begin{array}{l} \text{HSO}^2 \\ \text{SO} \end{array} \right\} = \left\{ \begin{array}{l} \text{HO} + \text{SO} \\ + \text{SO} \end{array} \right\}$	Hyposulphates, = $\text{H},\text{S}^2\text{O}^3$.
6.	$\left\{ \begin{array}{l} \text{HSO}^2 \\ \text{HO} \end{array} \right\} = \left\{ \begin{array}{l} \text{HO} + \text{SO} \\ \text{HO} \end{array} \right\}$	Sulphates saturated with oxygenated water = H^2,SO^3 .

THE SULPHATES = HSO^2 or MSO^2 .

Under this head I shall describe fully the most important compound the series, namely, oil of vitriol, commonly called hydrated sulphuric acid.

SULPHURIC ACID.

Formula, HSO^2 ; *Equivalent*, 49; *Specific gravity in the state of gas* 24.5; *Atomic measure*, 2 volumes. *In the gaseous salts when H is replaced by a basic radical, C^nH^{n+1} , the acid radical S loses its atomic measure, and the salt measures only one volume.*

Synonymes, *Hydrated Sulphuric Acid*; *Oil of Vitriol*. Systematic name, *Hydra sulphete*.

Properties of Hydrated Sulphuric Acid.—When sulphur is burnt in oxygen gas, and the gaseous combination of sulphur and oxygen is dissolved in water, and exposed to atmospheric air so as to absorb more oxygen, the liquid product is found to possess, in a very eminent degree, the distinguishing properties of acids. This liquid, when concentrated to the specific gravity of 1.845, is termed *oil of vitriol*. It freezes at -31° , and boils at 617° . It is caustic, and therefore poisonous. It has a powerful charring action on organic substances: small portions of which give it a brown colour. Its density is nearly twice that of water; for which body it has a strong attraction. When mixed with water, great heat is produced. It abstracts water from the atmosphere. Sulphuric acid is prepared, in the large way, by burning sulphur mixed with a small portion of nitre, in closed chambers lined with lead. The nitre furnishes oxygen to the sulphur, and the acid, as it is produced, combines with a quantity of water, which is forced into the chambers in the state of steam. This liquid acid is afterwards boiled, first in lead pans, and then in platinum retorts, to free it as much as possible from water. The use of sulphuric acid in chemistry, metallurgy, bleaching, dyeing, medicine, and other arts, is very extensive. It is required for the preparation of most other acids. Some metals dissolve in cold sulphuric acid, and disengage hydrogen gas. Other metals dissolve in hot sulphuric acid, and disengage sulphurous acid gas. In general, the cold diluted acid produces *basyulous* salts, and the hot strong acid produces *basylic* salts.

Sulphuric acid is to the chemist what iron is to the mechanic, once his most indispensable work-tool, and the raw material with which he fabricates numberless important articles. The demand for it is enormous. In Great Britain alone, the yearly consumption exceeds a hundred thousand tons.

Great care is required in operations performed with this acid. It must never be carelessly dropped about, nor allowed to run down the outside of bottles, as it burns everything that it touches.

Production of Sulphuric Acid.—I. Mix six parts of sulphur with one of nitre, in a small cup, supported over the surface of water in a dish. Ignite the mixture, and place over it a large glass, so as to rest into the water, and form a close vessel. By this process the water in the dish is converted into very dilute sulphuric acid, as may be known.

by applying the proper tests. Sulphuric acid is also produced by boiling sulphur in aqua regia, or in strong nitric acid.

2. The apparatus recommended to be used in the production of sulphurous acid (page 595, process 2), is to be set in action, and the point of a tube from which nitrous gas is issuing, is inserted into the mouth of the tube, whereat the sulphur is put in for burning. The current of air then carries forward a mixture of sulphurous acid gas, moist nitrous gas, and superfluous atmospheric air. This mixture must not, in this case, be drawn through a V-tube, but through a large receiver containing a small portion of water, in which sulphuric acid will gradually be deposited.

3. When a mixture of sulphurous acid gas and moist atmospheric air is carried thus through a wide glass tube over a mass of spongy platinum, heated to dull redness by a spirit-lamp, concentrated hydrated sulphuric acid is immediately produced. Too strong a heat hinders the production of the acid.

4. If two volumes of sulphurous acid gas and one volume of oxygen gas, both pure and dry, are thus treated, they produce sulphuric anhydride, $SO + SO + O = S,SO^3$.

5. Into a few drops of fuming nitric acid, placed at the bottom of a small bottle, pass a current of sulphurous acid gas. Vapour rises and white crystals form on the sides of the bottle. Add water. Effervescence occurs from the discharge of NO and NOO. The solution contains nitric acid and sulphuric acid. The first may be boiled off and the latter obtained alone.

6. Bind a quantity of threads that have been dipped into melted sulphur, round an iron wire. Adjust the wire to the cork of a large bottle, in which a little water has been put. Set fire to the sulphur, and burn it in the bottle. While the bottle is full of the vapour of sulphurous acid, dip into it a slip of wood thoroughly wetted with strong nitric acid. Immediately, red vapours of peroxide of nitrogen, arising from the decomposition of the nitric acid, will proceed from the wood through the entire bottle. After some time, the bottle may be shaken, to mix the water with the vapours present; and the water will then be found to contain sulphuric acid.



7. Boil sublimed sulphur in strong nitric acid. It gives off nitrous gas and produces sulphuric acid.

8. Arrange the apparatus represented by fig. 457. A is a large glass receiver, the inside of which has been moistened with water. B is a flask for preparing sulphurous acid gas = SO, from copper and concentrated sulphuric acid by process 2, described at page 593. C is a flask for preparing nitric oxide = NO, from copper and diluted

nitric acid, as described in process I, page 289. When these gases are mixed in the glass receiver A, which contains air and vapour of

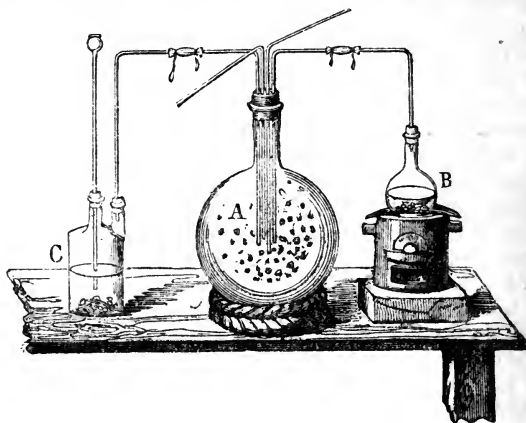

457.

water, they act upon one another, so as to produce hydrated sulphuric acid. At first the nitric oxide = NO, combines with the oxygen of the air, and produces peroxide of nitrogen = NOO. Next, a white crystalline deposit is formed on the sides of the receiver, the composition of which is not agreed upon by different chemists. It seems to differ according to the presence or absence of water, and there are probably these two compounds:—

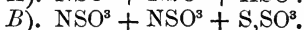
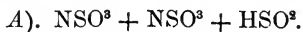

The second of these salts is a combination of three anhydrides. The first contains two anhydrides and one atom of hydrated acid. When water comes into contact with either of these salts, decomposition occurs, hydrated sulphuric acid is produced, and oxides of nitrogen such as NO and NOO, are set free. The oil of vitriol falls in the liquid state to the bottom of the vessel, the nitric gases act upon other supplies of sulphurous acid, air, and vapour, and the production of sulphuric acid thus proceeds continuously.

Reaction of Water with the Compound A:—

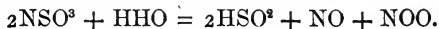

Reaction of Water with the Compound B:—

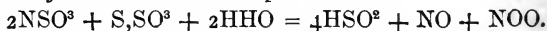

As the nitric oxide NO, requires oxygen O, to convert it into peroxid

of nitrogen NOO , the atmospheric air in the glass receiver must, like the water and the sulphurous acid, be from time to time renewed. A small quantity of the nitrogen compound serves in this way to convert a large quantity of sulphurous acid into sulphuric acid.

9. *Manufacture of Oil of Vitriol in Lead Chambers.*—The following engravings are taken from Regnault's *Course of Chemistry*, from which work the description of the process is also abstracted. In the manu-

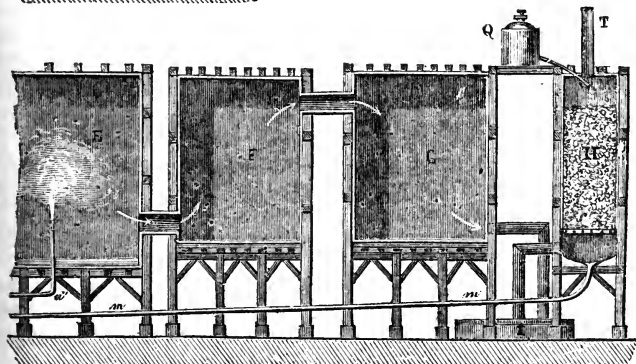
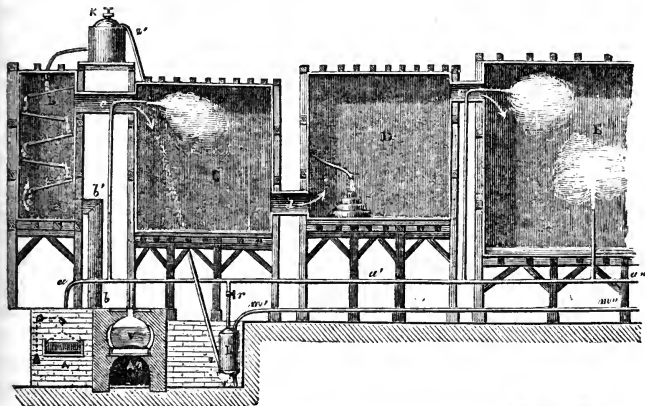

458.

facture of sulphuric acid in the large way, the glass receiver A, of experiment 8, is replaced by large chambers, formed of sheets of lead soldered by the oxyhydrogen blowpipe into continuous walls, which are kept in position by suitable outside walls of timber, &c. The sulphurous acid is supplied by the combustion of sulphur in a furnace, through which atmospheric air passes, and sweeps the gas into the

chambers. The nitric oxides are supplied by the direct application of hydrated nitric acid in a manner to be specially explained. Oxygen is supplied by the current of air which accompanies the sulphurous acid, and water is thrown into the chambers in the state of jets of steam.

The process to be described was invented by Gay Lussac, and is followed in France. In England and Scotland, nitre and not nitric acid is used to supply the requisite nitrogenous compounds.

Letters A A', fig. 458, represent two furnaces, in which the sulphur is burnt. They are connected together. One of them is shown in section. The sulphur is burnt on a plate of iron. The heat resulting from the combustion is employed to produce the steam required for use in the lead chambers. For that purpose, a boiler, V, is placed in each furnace, just above the iron plate on which the sulphur is burnt. A pipe, marked *a a' a''*, conducts the steam into the various chambers.

The two sulphur furnaces communicate with the same chimney, *b b'*, which is at least twenty feet in height, in order to give such ascensional force to the gases which it delivers as will enable them to traverse the rest of the apparatus. This chimney, *b b'*, conducts the mixture of sulphurous acid gas and heated air into the leaden drum marked B B, in which are disposed in inclined positions several plates of lead, on the uppermost one of which there falls continuously and in a regulated quantity, a stream of concentrated sulphuric acid strongly charged with nitric oxides; which mixture is produced by an operation to be explained presently. The stream of acid flows from the vessel R, and after running in cascades from shelf to shelf, it gathers at the bottom of the drum B B. The current of sulphurous acid gas, meeting with this rain of nitrogenised acid, is partly converted by it into sulphuric acid, and partly goes on, carrying with it the rest of the nitric oxides in the state of gas, and accompanied by a mass of heated atmospheric air, through the tube *c*, into the chamber marked C. This chamber is of small size, namely, about 100 cubic yards' capacity. Into this chamber, and close to the entrance by which the mixed gases have arrived, comes the first jet of high-pressure steam from the boiler V. The reaction which has already been described as taking place among sulphurous acid, nitric oxides, and vapour of water, occurs here. In consequence of that reaction, sulphuric acid, HSO^2 , is produced, and falls in a liquid state to the floor of the chamber.

The residue of the gases then passes by the tube *d*, into a second chamber, D, of nearly the same dimensions as the chamber C. In front of the tube *d*, there is fixed on the floor of the chamber a pyramid of earthenware in the form of a *chateau d'eau*, a series of cascades, on the top of which there runs continuously a thin stream of liquid nitric acid. A vessel outside the leaden chambers, and not represented in the figures, supplies this acid. The form of the pyramid is such as to

scatter this nitric acid as widely as possible. The current of sulphurous acid gas and air dashes against it. The whole are mingled together. Decomposition takes place. Sulphuric acid is formed, and is deposited on the floor of the chamber, but it is mixed with a considerable proportion of nitrous compounds. From the floor of chamber D to that of chamber C, the acid is run off by a tube, the floor of C being made lower than that of D to facilitate this operation. As the acid in C is commonly surcharged with sulphurous acid, and that in D with nitric oxides, the two liquors correct each other, and give an additional quantity of liquid sulphuric acid.

The mixed gases now proceed, by the tube *e*, into a very large lead chamber, E, where the principal reaction of the gases upon each other takes place, and where the largest quantity of sulphuric acid is produced. Into this chamber jets of steam are thrown at many different parts. In the figure three jets are represented. The gases are retained in this chamber for some time, to secure as perfect a decomposition of them as is possible. Liquid sulphuric acid gradually accumulates on the floor of the chamber, and into this liquid the acid is gradually run from chamber C; the floor of E being made lower than that of C to permit this transference of liquid.

The gases are not yet quite deprived of their useful ingredients. The temperature of the chamber E is pretty high, and when the gases leave it, they carry off a quantity of sulphuric acid in vapour, as well as some remains of the nitric oxides. To gain these substances, the gases are made to pass through two lead drums, F and G, which serve as refrigerants, and in which sheets of lead are disposed in such a manner as to interrupt the gaseous current, and give time for the deposition of the cooled vapours.

Thence the gas passes into the refrigerant I, seen at the bottom of the figure, and which is cooled externally by water; and, finally, it enters the lead drum H, and escapes by the tube T into the air.

The drum H is filled with large fragments of coke, supported on a diaphragm *s*, and on which a continuous current of concentrated sulphuric acid is made to run from the vessel Q. This acid absorbs all the nitrous vapours that may reach as far as the drum H, and when it arrives at the bottom of the drum, it passes by the inclined leaden pipe *m m' m''*, into the vessel L. This is the concentrated sulphuric acid, charged with nitrous vapours, of which I have already spoken as being supplied by the vase R to the drum B B.

The transvasation of the nitrified acid from the vase L to the vase R is effected by the following simple contrivance: The top of the vase R communicates with the bottom of the vase L by a tube *z z'*, and the top of the vase L is connected by a tube, furnished with a stopcock *r*, with the main high-pressure steam-pipe, *a a' a''*. When the stopcock *r* is opened, the force of the steam, acting on the acid in the vase L, is

sufficient to press it up into the vase R. When enough acid has been forced up, the stopcock *r* is closed.

When the sulphuric acid is taken from the lead chambers, its specific gravity is about 1.45. If retained longer in the chambers, it absorbs and retains nitrous fumes, which damage its quality. The acid of 1.45 is evaporated in shallow leaden pans to the specific gravity of 1.72. Its boiling-point is now become so high that it cannot be safely condensed any further in contact with lead. The acid is then boiled in glass retorts, or in stills made of platinum, until the excess of water is driven off, and it is brought to the specific gravity of 1.845, in which state it is called *oil of vitriol*.

It seems scarcely necessary to remark that such a manufacture as that of oil of vitriol requires great attention on the part of its superintendent to insure a sufficient supply, without giving an excess, of the several materials from the complicated reactions of which the sulphuric acid is produced; but the details which are needful to guide the manufacturer need not be particularised in an explanation of the process which is purely elementary.

Distillation of Sulphuric Acid.—The preceding explanation shows that sulphuric acid is one of those reagents which the chemist cannot make for his own use, but must procure from a chemical manufacturer. The acid can be bought for use in a state of purity; or the common acid can be purified by distillation, but it is dangerous to expose it to a boiling heat without proper precautions, as it boils with explosive violence. The distillation of this acid cannot be safely executed by an unpractised experimenter.

The best distilling apparatus consists of a retort and receiver of the form shown by fig. 299, page 299, connected by an adapter, formed of a very long and wide tube. All these should be of hard German glass, free from lead. The tube should go over the neck of the retort, and project into the middle of the receiver. There must be no corks or lute at the joints, and no condensing water applied to the receiver. The retort must contain a quantity of crooked wire or foil of platinum, and the heat is best applied by means of a circular gas flame, produced by a radiating gas-burner.

Berzelius recommended the application of heat to the sides of the

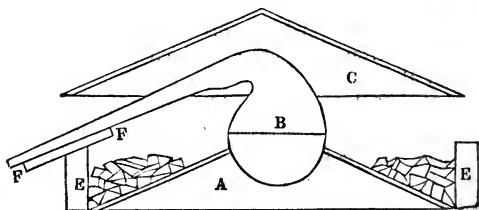

retort, as shown by fig. 459. A is a cone of sheet iron, with a hole to fit the retort; a charcoal fire is made on this cone, and hemmed in by the bricks E E. An iron hood, C, serves to prevent the condensation of the acid before it reaches the neck of the retort. A tile, FF, is used to keep the neck of the retort from the hot brick E. The same end is accomplished by resting the retort on an empty iron pot, put within a furnace, and making the charcoal fire round about the outside of the pot. The object of these contrivances is to prevent the violent succussions that occur when heat is applied directly to the bottom of the retort.

The great power that platinum wire possesses of facilitating the quiet evaporation of sulphuric acid and other liquids may be shown by hanging a twisted platinum wire, previously cleaned and ignited, in a flask containing water, strong nitric acid (sp. gr. 1.42), or oil of vitriol. The boiling in all cases is effected at a lower temperature than when the wire is omitted, and proceeds without bumping. If these liquids are brought near to the boiling point, and the wire is then put in, boiling commences immediately, and in the case of oil of vitriol, violently. It is therefore dangerous to put platinum wire into oil of vitriol when hot. It must be put into the retort with the cold acid.



460.

Regnault gives the following instructions for the distillation of oil of vitriol: Platinum wires are to be put into the retort to lessen the bumping of the acid, and the heat is to be applied, not to the bottom of the retort, but laterally, as is represented by fig. 461. The charcoal is placed in a double cage of iron wire, which applies the heat only to the sides of the retort, while the bottom is left free. The dome A is used to prevent the too ready condensation of the vapours in

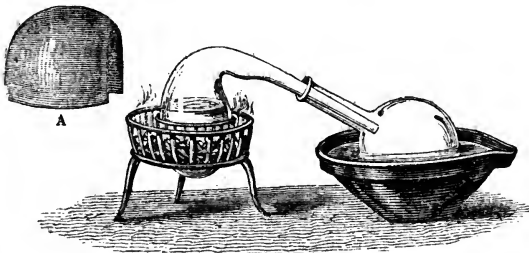

461.

the neck of the retort. With this arrangement, the steam bubbles are disengaged either on the platinum wires, or at the sides of the retort, and not at the bottom, under a heavy weight of acid.

SULPHURIC ACID. TABLE A.

Test Atom $\text{HSO}^2 = 49$ grains.

Specific Gravity of the Acid.	Per Centage of Oil of Vitriol of 1.846.	Grains of HSO^2 in 1 Septem.	Test Atoms of HSO^2 in 1000 Septems.	Septems containing 1 Test Atom of HSO^2 .	Septems containing 1 lb. of the Acid.	Grains of HSO^2 in 1 lb. of the Acid.	Money Value of 1 lb. of the Acid.
1.	2.	3.	4.	5.	6.	7.	8.
1.846	100	12.922	263.7	3.79	541.7	7000	1.00
1.8438	99	12.778	260.7	3.84	542.3	6930	.99
1.8415	98	12.633	257.8	3.88	543.	6860	.98
1.8391	97	12.487	254.8	3.92	543.8	6790	.97
1.8366	96	12.355	252.1	3.97	544.4	6720	.96
1.834	95	12.196	248.9	4.02	545.3	6650	.95
1.807	90	11.384	232.3	4.30	553.4	6300	.9
1.708	80	9.5648	195.2	5.12	585.5	5600	.8
1.65	75	8.6625	176.8	5.66	606.1	5250	.75
1.5975	70	7.8278	159.5	6.27	626.	4900	.7
1.486	60	6.2412	127.3	7.86	672.9	4200	.6
1.3884	50	4.8594	99.2	10.1	720.2	3500	.5
1.3	40	3.64	74.3	13.5	769.2	2800	.4
1.2184	30	2.5586	52.2	19.2	820.7	2100	.3
1.141	20	1.5974	32.6	30.7	876.4	1400	.2
1.0682	10	.7477	15.2	65.8	936.2	700	.1
1.0336	5	.3618	7.4	135.	967.5	350	.05
1.0074	1	.0705	1.44	694.	942.6	70	.01
		.049	1.	1000.			

Estimation of the Strength of Diluted Sulphuric Acid.—The two tables of sulphuric acid, marked A and B, are constructed exactly on the same plan as those of nitric acid, which have been explained at page 304. It is therefore needless to give any explanation in this place. The comparative strengths of the two acids are shown at page 106.

Determination of the Chemical Strength, or degree, of a given sample of Sulphuric Acid.—Instructions for performing this analysis are given at page 104; but in that case the test liquor, against which the sulphuric acid is tried, is a solution of carbonate of soda; the special process which demanded the use of the carbonate being part of a series of operations for constructing a set of *standard solutions* for the general purposes of centigrade testing. When the standard solutions are prepared, that which is to be taken to test sulphuric acid is not carbonate of soda, but caustic potash, or caustic ammonia. See page 110.

SULPHURIC ACID. TABLE B.

Test Atom $\text{HSO}^2 = 49$ grains.

Grains of HSO^2 in 1 Septem.	Test Atoms of HSO^2 in 1000 Septems.	Septems containing 1 Test Atom of HSO^2 .	Grains of HSO^2 in 1 Septem.	Test Atoms of HSO^2 in 1000 Septems.	Septems containing 1 Test Atom of HSO^2 .
12·922	263·7	3·79	7·84	160·	6·25
12·887	263·	3·8	7·35	150·	6·67
12·838	262·	3·82	6·86	140·	7·14
12·789	261·	3·83	6·37	130·	7·69
12·740	260·	3·85	5·88	120·	8·33
12·691	259·	3·86	5·39	110·	9·09
12·642	258·	3·88	4·9	100·	10·0
12·593	257·	3·89	4·41	90·	11·1
12·544	256·	3·91	3·92	80·	12·5
12·495	255·	3·92	3·43	70·	14·3
12·446	254·	3·94	2·94	60·	16·7
12·397	253·	3·95	2·45	50·	20·0
12·348	252·	3·97	1·96	40·	25·0
12·299	251·	3·98	1·47	30·	33·3
12·25	250·	4·	1·225	25·	40·0
11·76	240·	4·17	·98	20·	50·0
11·27	230·	4·35	·735	15·	66·7
10·78	220·	4·55	·49	10·	100·
10·29	210·	4·76	·294	6·	167·
9·8	200·	5·	·245	5·	200·
9·31	190·	5·26	·196	4·	250·
8·82	180·	5·56	·098	2·	500·
8·33	170·	5·88	·049	1·	1000·

You will observe in the tables that oil of vitriol can occur of nearly 264 degrees of strength, which is about 53 times the strength of test alkalies of 5° . Hence, 1 septem of such acid would require for neutralisation 53 septems of alkali of 5° , and 5 septems of it would require 265 septems, which is an inconvenient quantity of a test liquor for use in one process. In trying sulphuric acid, it is advisable to measure off 10 septems, and dilute that quantity in a small test mixer to 100 septems, or to dilute 100 septems in a decigallon bottle to 1,000 septems, and then to take 5 or 10 septems of that diluted acid for analysis. When the testing is completed, the result is, of course, to be multiplied by 10, to show the actual strength of the undiluted acid.

Usual Impurities of Commercial Oil of Vitriol. — Sulphate of lead,

derived from the lead chambers; *sulphate of barytes*, sometimes added fraudulently to increase the specific gravity of the acid: these substances precipitate as white powders when the acid is diluted with water. *Arsenic*, when the acid is prepared from sulphur taken from iron pyrites, see Detection of Arsenic. *Oxides of nitrogen*, derived from the nitre or nitric acid used in the manufacture of the acid. When a strong solution of green vitriol is added to the undiluted oil of vitriol, the nitrous compounds produce a purple-red colour, where the test liquor comes into contact with the acid. Other less frequent impurities are *sulphurous acid*, *hydrochloric acid*, and *sulphate of potash*. The nitric oxides can be removed by mixing the oil of vitriol with a little sulphate of ammonia, previous to its distillation.

Condensation of Oil of Vitriol when mixed with Water.—*Two cold liquids, on being mixed together, produce a boiling-hot liquid; and the bulk of two liquids diminished by mixing them.*—1. Take a small phial about half full of cold water; grasp it gently in the left hand, and from another phial pour sulphuric acid very gradually into the water. The mixture will immediately become so hot that the phial cannot be held. 2. If a thin glass tube, three-eighths of an inch in diameter, containing a small quantity of water, be plunged into a mixture of one part water to four parts acid, the water in the tube will boil.—3. Take a glass tube, twelve inches long, and one-third of an inch wide, having two bulbs of an inch in diameter blown near the middle of it. Fit a

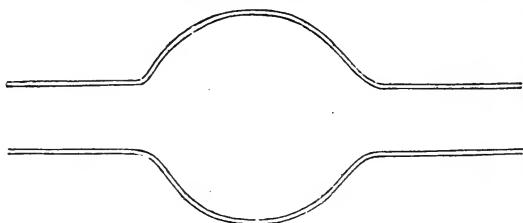

462.

long cork to each end of the tube. Fill half the tube and one of the bulbs with concentrated sulphuric acid. Then gently fill the other bulb and the rest of the tube with water, using a small long-necked funnel. Put in the cork. Invert the apparatus several times quickly to mix the liquids. The two corks serve as handles to the tube. The mixture becomes extremely hot. If the tube is held near phosphorus, it sets it on fire. If it is placed upright, you can see by the vacant space in the tube how much the mixture diminishes in bulk. When the mixture is cold, the vacant space will be one and a half inch of the tube. If the sulphuric acid is tinged red by carmine, or blue by indigo, the operation is better seen by spectators at a distance.

USE OF SULPHURIC ACID AS A SOLVENT.

Sulphuric acid is employed as a solvent in two states, first, *concentrated*; secondly, *diluted* with four or five times its bulk of water. It requires to be previously purified by distillation.

Diluted sulphuric acid can frequently replace both nitric acid and hydrochloric acid as a solvent of earthy and metallic oxides; but its use as a general solvent of substances of unknown nature is limited by the circumstance that it produces a great number of compounds that are more or less insoluble both in water and acids, such as sulphate of barytes, sulphate of lead, and so forth. To avoid the chance of converting the subject of experiment into one of these insoluble compounds, it is necessary in all cases to attempt its solution in other acids, and to restrict the use of sulphuric acid to the accomplishment of particular cases of solution or decomposition where its energetic action is peculiarly important, and where the other two acids have proved to be inactive.

Substances Decomposed by Concentrated Sulphuric Acid.

Fluorspar. It disengages hydrofluoric acid gas, and leaves sulphate of lime. If the decomposition is effected in glass or porcelain vessels, it disengages hydrofluosilicic acid gas.

Alumina, Ignited. It must be first digested with concentrated sulphuric acid, and then mixed with water.

Clays. From several mixtures and combinations of alumina with silica, the alumina can be dissolved by digestion with concentrated or moderately diluted sulphuric acid.

Peroxides. With disengagement of oxygen gas, to wit those of manganese and of lead.

Oxalic Acid and Oxalates. They disengage a mixture of carbonic acid gas and carbonic oxide gas, and leave sulphates in solution.

Siliceous Minerals. Most of them are decomposed by a prolonged digestion. But sulphuric acid is not much used for that purpose.

Substances Insoluble in Diluted Sulphuric Acid.

Metallic Acids which do not dissolve in water.

Siliceous Minerals.

Sulphate of Barytes, } Insoluble in water
Sulphate of Strontium, } and in acids.

Sulphate of Lead. Soluble in a large quantity of very dilute nitric or hydrochloric acid.

Sulphate of Lime,

Sulphate of Mercury,

Sulphate of Silver,

{ Very sparingly
soluble in water;
soluble in nitric or
hydrofluoric acid,
but precipitable
thence by sulphu-
ric acid.

Substances Soluble in Diluted Sulphuric Acid.

Metallic Iron and Zinc. With disengagement of Hydrogen gas.

Sulphide of Iron, *in*

Sulphide of Antimony,
in warm acid.

{ With disengage-
ment of sulphu-
retted hydrogen
gas.

Action of Sulphuric Acid on Organic Bodies.—A striking experiment illustrative of the powerful action of concentrated sulphuric acid on organic matters consists in mixing about equal bulks of very strong

syrup and oil of vitriol. In a few seconds the mixture becomes black and hot, effervesces, and is at last converted into a solid magma of charcoal, or rather of a highly carbonised substance resembling charcoal in appearance. The hydrogen and oxygen of the sugar appear to form water, under the influence of the powerful affinity of the sulphuric acid for that compound, the carbon of the sugar being set at liberty.

Detection of Sulphuric Acid in Vinegar, &c.—Dissolve white sugar in water, and evaporate the solution in a white flat porcelain capsule, so as to produce a thin varnish of sugar. Upon this, while still warm, let fall a drop of the liquor which is suspected to contain free sulphuric acid (such as adulterated vinegar). The water of the diluted acid will evaporate, and the acid, becoming concentrated, will char and blacken the film of sugar.

Purification of Sulphuric Acid from Arsenic.—Dilute the sulphuric acid with 36 per cent. of its weight of water, and pass through it a strong current of sulphuretted hydrogen gas. Allow the sulphide of arsenic to settle down; filter the acid through clean quartz sand; concentrate the acid by boiling it in an evaporating basin; and finally submit it to distillation.

SULPHATES.

When metals are dissolved in diluted hydrate of sulphuric acid they produce salts that are termed sulphates. Thus:—

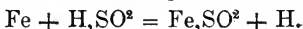

See page 195. And when hydrated oxides of metals, or bases, dissolve in hydrated sulphuric acid, they also produce sulphates. Thus, hydrate of lime produces sulphate of lime, and hydrate of soda produces sulphate of soda; both reactions being attended with the production of water.

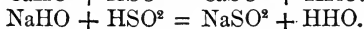

Detection of Sulphates. See page 96.—Sulphates that are insoluble in water: those of barytes, strontian, and lead. Nearly insoluble: lime, silver, and mercury. Most of the other sulphates are soluble in water. Nearly all of them are insoluble in alcohol. The solutions of the sulphates of the alkalies, and of lime, magnesia, manganese, and silver do not redden blue litmus paper; but solutions of the sulphates of other metals do redden litmus. The sulphates of the alkalies and earths are not decomposed by a red heat. But the sulphates of the common metals are decomposed when made red hot.

The sulphate of barytes is one of the most insoluble salts known to exist, and as it bears a red heat without alteration, it is by means of its solution of barytes (the nitrate or chloride) that sulphuric acid is separated from other substances in quantitative analyses. The white precipitate, formed by sulphate of barytes, is insoluble in nitric acid,

which it is distinguished from other white precipitates produced by solutions of barytes.

BISULPHATES.—The salts so called are double salts in which sulphate of hydrogen is combined with another sulphate, such as $\text{KSO}^2 + \text{HSO}^2$. In the same way, the alcohol radicals produce bisulphates, such as $\text{C}^2\text{H}^5\text{SO}^2 + \text{HSO}^2$.

DOUBLE SULPHATES.—These are derived from the *bisulphates*, by the replacement of the hydrogen by some other basic radical. There are two kinds of such double sulphates; namely, those in which both the basic radicals are metals, and those in which one of the basic radicals is a metal, and the other a hydrocarbon. A difficulty in the theory of these salts has been examined at No. 20), page 417.

TRIBASIC SULPHATES.—The formulæ of these salts is M^3SO^3 or $\text{M}_3\text{SO}^2 + \text{M}_3\text{MO}$. They are not practically important. See page 425.

Fuming Nordhausen Sulphuric Acid.

Formula, $\text{SSO}^3 + \text{HSO}^2 + \text{HSO}^2$; *Systematic name*, Sulpha sulphite bis hydra sulphete.

Pure Nordhausen sulphuric acid is a crystalline salt, composed of two equivalents of oil of vitriol and one equivalent of sulphuric anhydride. It is prepared by distillation from roasted green vitriol, from which a part of the water of crystallisation is expelled, but enough of which is permitted to remain to afford an acid of the above constitution. In addition to hydrated and anhydrous sulphuric acid, the Nordhausen acid usually contains sulphurous acid and other impurities. In the liquid state, its sp. gr. is about 1.9. By dilution with water, it is converted into oil of vitriol.

PENTATHIONATES.

Formula of the Hydrated Acid, HSO ; *Equivalent*, 33; *Systematic name*, Hydra sulphate.

The pentathionic acid is produced by the action of sulphide of hydrogen, HS, upon sulphurous acid, SO. Half the sulphur is separated, and the hydrated acid remains in solution.



It can be concentrated over a water-bath to sp. gr. 1.3, and afterwards in vacuo to sp. gr. 1.6; but it has never been brought exactly to the composition of HSO.

This acid cannot have its basic hydrogen replaced by a metallic radical, but it can have the hydrogen of one atom out of two thus replaced, and it so produces salts in agreement with the formula $\text{HSO} + \text{MSO}$. These salts are called *Hyposulphites*. It is also possible to have acid salts in accordance with the formula $\text{BaSO} + 4\text{HSO}$, and this acid salt can be deprived of water so as to produce the salts:—

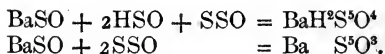

These preparations lead to the inference, that besides the anhydride = SSO^3 , derived from sulphuric acid, there exists another anhydride = SSO , derived from the present acid, for $\text{HSO} + \text{HSO} = \text{HHO} + \text{SSO}$. The pentathionates have no practical importance.

SULPHITES.

Sulphurous acid, acting upon aqueous alkaline solutions, produces two kinds of sulphites, A) *neutral*, and B) *acid*:—

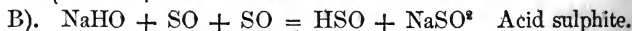
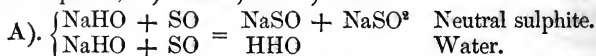

According to this view a sulphite, whether neutral or acid, is a compound of a sulphate = MSO^2 with a pentathionate = MSO or HSO . The sulphites of the alcalies dissolve in water. Those of the earths and metals are insoluble. The neutral sulphites of potash and soda are alkaline in their reaction on test-papers. The bisulphites are acid in relation to test-papers. Sulphuric acid added to their solutions, converts the bases into sulphates and expels sulphurous acid gas, but gives no precipitate of sulphur, by which the sulphites are distinguished from the hyposulphites.

The sulphites of the metals when ignited produce three-quarters sulphates and a quarter sulphide:—

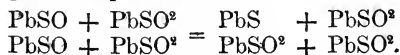

Antichlor.—When in the process of bleaching cotton goods with chlorine, the bleaching liquor is used too strong, or when the bleaching liquor has not been well washed out of the bleached goods, the cotton fibre is weakened and the goods rot. To guard against this mishap, the sulphite of soda has lately come into use in the arts, and passes by the name of antichlor. It is a crystallised soluble salt, without odour, but it gives off sulphurous acid when acted on by sulphuric acid.

HYPOSULPHITES.

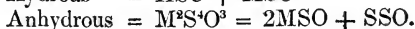

The hydrous hyposulphites are merely acid pentathionates. The anhydrous salts are produced by the abstraction of HHO from two atoms of the hydrous salts:—

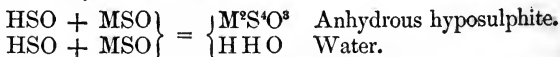

No such acid exists as the hyposulphurous acid; the reason being tha

there exists actually no other acid than the pentathionic acid = HSO (which is most absurdly so named), and that no other is needed. The hyposulphites are merely acid salts of pentathionic acid, just as the bisulphates are acid salts of sulphuric acid; while the dried hyposulphites are parallel to the dried bisulphate of soda; see page 596. Thus,—

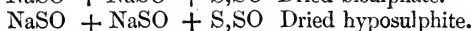

Preparation of Hyposulphites.—When zinc is dissolved in an aqueous solution of sulphurous acid, we obtain, without liberation of hydrogen gas, a mixture of bisulphite of zinc and hyposulphite of zinc.

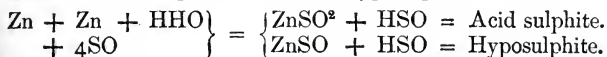

A hyposulphite is also produced when an aqueous solution of an alkaline sulphite is heated in a close vessel with an excess of sulphur. This is one of the processes by which the hyposulphites are commonly prepared.

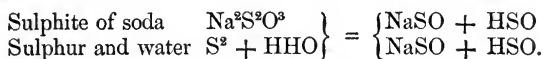

When the hyposulphites are dried, they give off all their hydrogen with as much oxygen as converts the hydrogen into water, as I have explained above. When treated with sulphuric acid, they produce a sulphate, disengage sulphurous acid gas, and give a deposit of sulphur:—

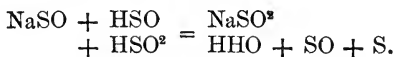

SULPHURIC ACID, SATURATED WITH OXYGENATED WATER.

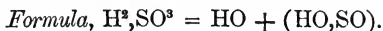

Particulars will be found in Thenard's account of the reactions of oxygenated water. See his System of Chemistry.

HYPOSULPHATES.

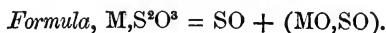

These two classes of salts are of no practical importance. I have cited them only to show how the sulphates can combine on the one hand with an oxidised acid radical, and on the other with an oxidised basic radical, and form two new classes of salts.

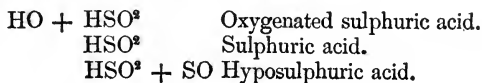

SULPHIDE OF HYDROGEN.

Formula, HS; Equivalent, 17; Specific gravity of gas, 17; Atomic measure, 1 volume. When it forms salts, H is replaced by a basic radical, M. If the salt is gaseous, the acid radical S loses its atomic measure.

Synonymes, *Sulphuretted Hydrogen; Hydrosulphuric Acid.* Systematic name, *Hydra sulph.*

Preparation of Sulphuretted Hydrogen Gas.—1. Mix in a gas-bottle two parts of iron filings with one part of sublimed sulphur; add as much water as will make the whole into a thick paste. Heat the mixture for some time, then add strong hydrochloric acid, and again apply heat. The gas produced in this way is liable to be mixed with hydrogen gas.

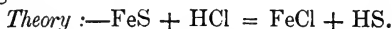

2. Mixed pulverised grey sulphide of antimony = SbcS , with four or five times its weight of hydrochloric acid, sp. gr. 1.1. It is necessary to apply a slight heat to the bottle which contains the mixture. The gas may be collected over hot water, salt and water, or mercury.

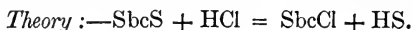

The compound SbcCl is the stibic chloride, often called terchloride of antimony. The apparatus shown by fig. 463 may be used for either of the above processes, as both require to be heated, and in both cases a wash-bottle is needful, in which the gas can be purified from hydrochloric acid or from small particles of metal. But gas produced by the first process, even after this purification, still carries over free hydrogen, which often interferes with the use of the sulphide of hydrogen in analytical operations.



463.

3. A method of preparing and supplying sulphide of hydrogen in minute testing is described at page 75.

4. The best materials for preparing sulphide of hydrogen gas, for general purposes, are fused sulphide of iron and diluted sulphuric acid. When the sulphide of iron has been properly made, it gives off no free hydrogen. As the preparation of the gas from these materials requires no heat, the apparatus is arranged accordingly. Fig. 464 represents a convenient gas-bottle for this purpose. *a* is a cylindrical bottle of about ten ounces capacity, when it is to be used for the testing of solutions of metals.

b is a circular disc of wood with a milled edge, to which is cemented a flat cork, adapted to the wide neck of the bottle, *a*. The piece of wood thus fitted to the cork of a gas-bottle serves several useful purposes. It stops up the pores, which commonly are found in flat corks, and makes them air-tight; it gives strength to the cork when it is to carry two or three different glass tubes, and it serves as a handle by which the cork with its tubes can be conveniently fixed into the bottle or be removed from it. *d* is a glass tube-funnel for the insertion of acid without removing the stopper. *e* is a glass tube of half-inch bore, with a mouth slightly funnel-shaped; *f* a narrow glass tube for passing the gas into the metallic solution contained in the test-glass *g*. This tube must be changed or washed for every new experiment, because the metallic sulphide produced by the action of the gas

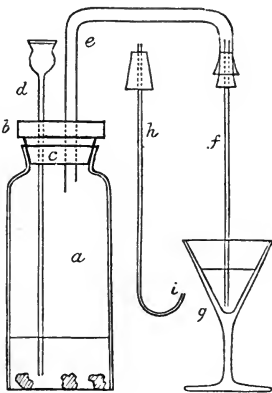

464.

upon the metallic solution rises up the tube both inside and outside, and soils it. The tube *h* is intended to be used with this gas-bottle, when it is employed for gases that are to be collected over water. It is adapted to the tube *e*, and must be bent and lengthened to suit the size or distance of the pneumatic trough, which is used in connection with it.

Lumps of fused sulphide of iron are put into the bottle *a*, and are covered with water to the height of about an inch and a half. The apparatus is then fitted together, and sulphuric acid is passed in gradually by the tube-funnel *d*. The gas speedily passes from the tube *f*, into the glass *g*. The gas should pass very slowly, because a rapid current escapes absorption, and diffuses its most noisome odour and poisonous powers in the atmosphere of the apartment where the experiment is made. To guard against unpleasant and dangerous consequences, the operation should always be performed in a place that is properly ventilated.

As the general purpose of preparing sulphide of hydrogen is to pass it into a liquid which is presumed to contain a metal, in order to ascertain what coloured precipitate it gives, the size and height of the bottle are adapted to this object. The tube *f* is made of such a length, or the glass *g* is so raised, that the tube nearly touches the bottom of the glass, so as to make the gas pass through as much as possible of the solution. When the operation is over, and no more gas is required, the stopper *b c* is lifted from the bottle, the liquid is thrown away down a sink, out of doors if possible, the residue of the solid sulphide of iron is

rinsed with water, which is also thrown away, the stopper is then replaced, and the sulphide of iron is covered with clean water, to be ready for a new experiment. In this state it gives off no offensive odour, and may be set aside till again required.

5. When only a small quantity of the gas, or a slow current of it is required, the apparatus may be modified as shown in the annexed figure.

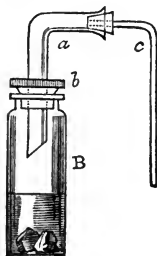

465.

There being no funnel to this apparatus, the sulphuric acid and water must be mixed and put into the bottle before the cork is inserted. When a slow current of gas is desired, as in all cases of testing, one or two large lumps of sulphide of iron and a little weak acid must be taken. When the current of gas is to be more rapid, the sulphide may be powdered, and the acid be less dilute.

6. The apparatus represented by fig. 466, has recently been contrived for the preparation of sulphide of hydrogen gas. *a* is a bottle of ten or twenty ounces capacity, according to the quantity of gas required. It is made with a broad glass foot to prevent its overturning from the weight of the fittings applied to its mouth.

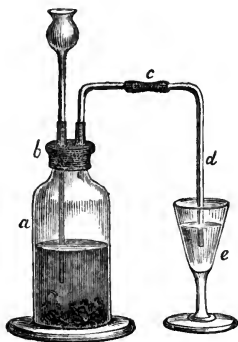

466.

b is a cap of vulcanised caoutchouc with two necks, one for the funnel and the other for the gas-leading tube. *c* is a caoutchouc connector. *d* is a testing-tube, easily changeable at *c*. *e* is the test-glass, containing the metallic solution that is to be tested.

Whenever the gas is required pure, any of these bottles can be connected with a wash bottle, as shown by fig. 463.

7. *Kipp's Apparatus*.—It would be very convenient, in large chemical laboratories where sulphide of hydrogen gas is required hourly, to have an apparatus somewhat on the plan of the hydrogen apparatus, represented by fig. 195, page 203, from which the gas could be promptly drawn when required. It is, however, difficult to construct an apparatus that should entirely avoid the constant disengagement of as much gas as makes the surrounding atmosphere unpleasant and unwholesome. A still greater difficulty presents itself in the circumstance that the sulphide of iron employed to produce the gas soon becomes coated with a basic salt which is insoluble in the dilute acid that serves to decompose the sulphide of iron, and which consequently puts a stop to the production of the gas. The apparatus must then be dismantled, in order that the

basic salt may be washed off with water. That is a stinking process, which, if the apparatus is large, nobody likes to perform, and so the apparatus is neglected and rendered useless.

The form of apparatus in which these difficulties are best overcome, and which is actually practical, is that of KIPP, represented by fig. 467.

It is formed of glass, of about six times the size of this diagram, that is to say, the largest globe is about 6 inches in diameter, and the whole apparatus is about 18 inches high. The funnel-shaped neck of the uppermost globe is ground to fit the neck *c* air-tight, but it passes loosely through the neck *a*, where a loose collar of caoutchouc is put about it to prevent the falling of small lumps of sulphide of iron from the middle globe down into the lowermost globe. The middle globe is nearly filled with lumps of sulphide of iron, in the largest pieces that will pass through the neck *d*, which is then to be closed with a sound cork carrying a glass stopcock, and that carrying a caoutchouc tube terminating with a glass gas-delivery tube.

The charge of sulphide of iron being put in, the decomposing acid, consisting of 1 part of oil of vitriol mixed with 5 or 8 parts of water, is to be poured into the uppermost globe, from which it passes down into the lowermost globe, and thence up into the middle globe, the stopcock being opened to let out the atmospheric air. Sulphide of hydrogen is immediately generated, and as much of it is allowed to escape as serves to sweep the atmospheric air completely out of the apparatus. The stopcock is then closed, and the apparatus is ready for use.

The *quantity* of gas delivered by this apparatus depends upon the management of the stopcock. It can be delivered in single bubbles slowly, or in a rapid current. The delivery-pipe is made short or long, according to the depth of liquor into which it is to pass. It must, of course, be changed for every experiment. The syphon at the top of the apparatus must contain so much water as to allow atmospheric air to pass either way, into or out of the apparatus, according as the stopcock is open or closed. If any sulphide of iron falls down into the globe *b*

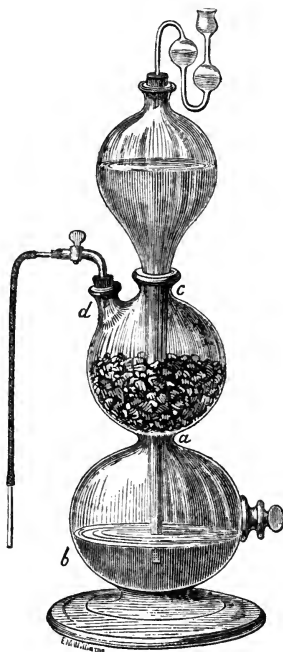

467.

it makes a constant disengagement of gas, which, if not observed, may drive so much acid up into the uppermost globe as to cause an overflow to take place. It is proper, therefore, that this apparatus should always stand in a stoneware pan to catch any acid that may overflow. When the apparatus requires cleaning, or the sulphide of iron needs washing, the acid can be poured off through the stoppered neck in the lowest globe.

PROPERTIES OF SULPHIDE OF HYDROGEN.

Sulphuretted hydrogen is a *gas*, whose component principles are hydrogen and sulphur. Its specific gravity is 1.7, being higher than that of common air. Its atomic measure is 1 volume. It burns with a pale blue flame, depositing sulphur. It does not support combustion. Its odour is extremely fetid, resembling that of rotten eggs. Its taste is sour. It reddens vegetable blues. It is absorbed by water. It blackens metallic silver and copper. It can be reduced to the liquid state by a pressure of about 17 atmospheres. Of all the gases, sulphuretted hydrogen is perhaps the most deleterious to animal life. A dog of middle size is destroyed in air containing only the 800th part of its bulk of it. Indeed, it has been proved, that to kill an animal, it is sufficient to make the sulphuretted hydrogen act on the surface of its body, where it is absorbed, by the inhalents. Yet to the presence of this gas is chiefly owing the beneficial medicinal properties of Harrowgate, Aix-la-Chapelle, Moffat, and some other mineral waters. Sulphuretted hydrogen is employed by the chemist as a reagent, because, with most metals, it produces coloured insoluble metallic sulphides, its hydrogen taking up the acid of the metallic salt. Thus:—

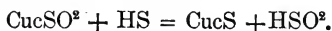

With the sulphides of the alkaline metals it combines to produce double sulphides. *Example*: $\text{KS} + \text{HS}$.

Metallic sulphides are often produced by the action of the carbon and hydrogen of decaying organic substances upon the oxygen of sulphate such as gypsum. Thus, $\text{CaSO}^2 - \text{O}^2 = \text{CaS}$. In this manner sulphides are formed in mineral springs, and also in stagnant sewers and cesspools.

When exposed to the action of air, nitrous acid, or chlorine, the solution of sulphuretted hydrogen becomes milky in consequence of the presence of reduced sulphur. If boiled, the gas is driven off undecomposed. If mixed and shaken with bleaching powder, the odour entirely disappears, the compound being decomposed.

EXPERIMENTS WITH SULPHURETTED HYDROGEN GAS.

1. A slip of paper having invisible figures drawn upon it with solutions of sugar of lead, nitrate of silver, or nitrate of bismuth, if passed into sulphuretted hydrogen gas, unfolds its secrets, by exhibiting legible

figures of a beautiful dark-brown colour. A caricature face drawn on a sheet of white paper is rendered visible by passing below it the bottle from which the gas is being disengaged.

2. Moistened blue litmus paper becomes red in this gas.

3. Paper dipped in nitric acid becomes yellow in sulphuretted hydrogen gas, acquiring a coating of reduced sulphur.

4. A mixture of equal measures of oxygen gas and sulphuretted hydrogen gas produces a sharp detonation when inflamed in the same manner as a mixture of oxygen and hydrogen gas. (Page 205.)

5. Sulphuretted hydrogen gas burns in contact with the air, with a pale-blue flame.

6. Sulphuretted hydrogen gas is absorbed by alkaline solutions, which produce solutions of metallic sulphides. $\text{KHO} + \text{HS} = \text{KS} + \text{HHO}$.

7. Tin and other metals, when fused in sulphuretted hydrogen gas, combine with the sulphur, and set the hydrogen at liberty.

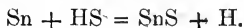

8. Sulphuretted hydrogen and sulphurous acid gas, in equal volumes, decompose each other, and produce hydra sulphate (hydrated pentathionic acid) = HSO , and deposit sulphur. The presence of water is required to dissolve the acid. $\text{HS} + \text{SO} = \text{HSO} + \text{S}$.

SULPHIDE OF HYDROGEN IN AQUEOUS SOLUTION.—It is often convenient to have a saturated solution of this gas. When freshly prepared, or protected from the atmosphere, its action is the same as that of the gas. I shall describe a few methods of preparing the solution.

1. In all cases, the water that is to be saturated with HS should be previously boiled to expel air, and afterwards be cooled in corked bottles. The gas is to be passed into the cold water till it ceases to be absorbed. The saturating point is soon reached, because water only absorbs twice or thrice its own volume of the gas. A bottle fitted like the wash-bottle of fig. 463 may be used, or better, such bottles as are represented by figs. 468 and 469, because the delivery-tube *a* can then



468.

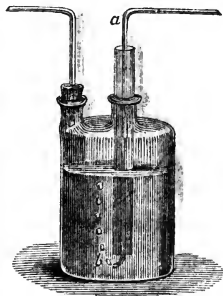

469.

be easily withdrawn from the fixed tube, and the water-bottle be shaken, to facilitate the absorption of the gas.

2. The simple apparatus shown by fig. 470 can also be used to prepare this solution. The gas is prepared in the flask *a*, and conveyed by

the tube *c* into the boiled water contained in the flask *b*. When the odour of the gas is smelt at the mouth of the flask *b* it should be exchanged for another flask. The stopper should be put into *b*, and the bottle be well shaken, the effect of which is to cause the water to absorb

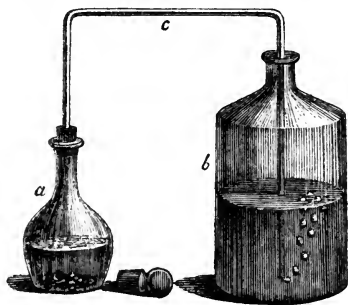

470.



471.

the gas. So long as the water remains unsaturated this shaking produces a vacuum in the bottle. To test this fact, hold the bottle in the position shown by fig. 471, and slightly loosen the stopper. If there is a vacuum in the bottle, air will pass through the liquor in bubbles, as represented by the figure. Exchange the flasks, continue to pass gas into each until these bubbles cease to appear after shaking the bottle. The water is then saturated.

3. To preserve such solutions in good condition, they should be filled into small phials containing 2 or 3 ounces, which should be well corked, tied down like soda-water bottles, and plunged mouth downwards into water, as is represented by fig. 472. A number of such bottles could be preserved for some time in a pan of water placed in a cold cellar.



472.

4. A small quantity of solution of sulphide of hydrogen can be conveniently prepared in a bent tube, either U-shaped or V-shaped, as described in the article on Ammonia, page 330.

5. *Mohr's Apparatus for a constant supply of Saturated Solution of Sulphide of Hydrogen.*—This apparatus is represented by fig. 473. I have copied it, with several figures and descriptions of operations respecting this gas, from MOHR'S *Commentar zur Preussischen Pharmacopœ*. This apparatus not only serves to prepare this solution of sulphide of hydrogen without contact with atmospheric air, but to preserve it in that condition, and yet to afford a supply of the solution either in drops or ounces readily and conveniently. The Wouff's bottle, *a*, is filled with air-free distilled

water; *b c* is an apparatus for preparing HS gas, made on the principle of the hydrogen gas bottle, fig. 195, page 203, and the carbonic acid gas apparatus, fig. 351, page 353; the jar *b* contains diluted sulphuric acid; the flask *c* contains lumps of sulphide of iron. The bottom of

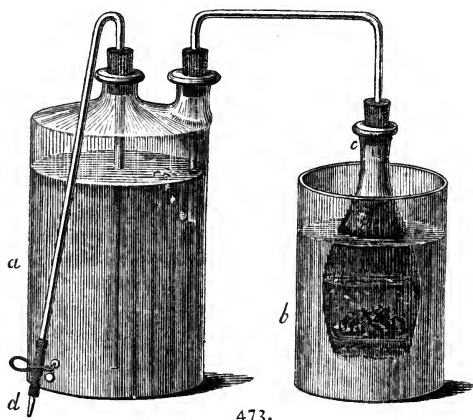

the flask *c* is cut out, and replaced by a perforated plate of lead, upon which the sulphide of iron rests at about three-quarters of an inch from the cut bottom edge of the flask. To set this apparatus in action, the vessels *a*, *b*, and *c* having received their respective charges, the cork which fixes the syphon *d* in the bottle *a* is loosened, and the apparatus being then placed together, HS gas is produced, and gradually drives out the atmospheric air from the vessels *c* and *a*. The syphon cork is then fixed, and HS gas is produced in *c* and absorbed by the water in *a*, until the latter is saturated. The acid then descends from the flask *c* into the jar *b*, and the operation stops. The syphon *d* is terminated outside by a glass delivery-tube attached by a caoutchouc connector and a pinchcock. Whenever the liquid sulphuretted hydrogen is required, the pinchcock is opened, a little liquor run off to waste, to clean the end of the delivery-tube, and then as much liquor is run out as the experiment requires. To supply the vacuum thus produced in the bottle *a*, the atmospheric air pressing upon the liquor in the jar *b*, drives it up into the flask *c*, and causes the production of as much HS gas as is required to make up the quantity run off by the syphon *d*. When the liquor of the bottle *a* is exhausted, a fresh supply of cold air-free distilled water is put into the bottle by the syphon neck, and the process of saturation goes on afresh. The corks of this apparatus should be coated with a mixture of fat and wax to make them air-tight.

SULPHIDE OF AMMONIUM = NH_4S .

HYDROSULPHATE OF AMMONIA = $\text{NH}_3\text{H} + \text{HS}$.

Equivalent, 34; Specific gravity of gas, 11 $\frac{1}{3}$; Atomic measure, 3 volumes. Systematic name of NH_4S , Ammonia sulphide.

In the liquid state, this is to be considered as a solution of sulphide of ammonium = $\text{NH}_4 + \text{S}$; but in the gaseous state, as a compound of sulphide of hydrogen = HS , with hydride of amidogen = $\text{NH}_3 + \text{H}$. This accounts for its atomic measure of 3 volumes, of which 2 volumes belong to ammonia, and 1 volume to hydrogen; sulphur, as usual, losing its measure in a gaseous salt. Read the discussion at page 315.

Preparation.—1). Mix chloride of ammonium with sulphide of barium, and distil the mixture. The distilled product consists of colourless, volatile, soluble crystals, having the above composition.

Theory:— $\text{NH}_4\text{Cl} + \text{BaS} = \text{BaCl} + \text{NH}_4\text{S}$.

2). Pass a current of sulphuretted hydrogen gas through a fixed quantity of a strong solution of ammonia, say 1000 septems of ammonia of 40°, until the liquor is saturated. The solution will be the *Double Sulphide of Ammonium and Hydrogen* = $\text{NH}_4\text{S} + \text{HS}$. To this solution add a second dose of 1000 septems of ammonia of 50°, when the solution will contain the neutral sulphide = NH_4S . Both these solutions are, like the solutions of HS in water, easily decomposed by atmospheric air.

The apparatus employed to contain the ammonia while being saturated with sulphuretted hydrogen may be a U-tube, a V-tube, a flask with narrow mouth, or any of the forms of apparatus cited in the last section.

3). In the preparation of this solution for use as a chemical test, the rule to follow is, to pass a slow current of sulphuretted hydrogen gas continuously into liquid ammonia of 30° or 40° of strength, until the solution ceases to give a precipitate with a solution of sulphate of magnesia. The solution must be preserved in a well-stoppered bottle of lead-free glass, because the reagent decomposes flint glass and deposits lead, and is itself readily decomposed by atmospheric air. It should be used soon after being prepared.

METALLIC SULPHIDES.—Sulphur combines with most metals, producing an important class of compounds called sulphides. The ores of many metals are sulphides. When sulphur is made to combine with a metal in the dry way, the act of combination is sometimes accompanied by ignition. See page 591. Most sulphides can be prepared in the wet way. Sulphur often combines with metals in multiple proportions, so as to produce compounds which agree with the formulæ MS^2 , MS^3 , MS^4 , MS^5 , &c. These supersulphides lose a portion of the sulphur when subjected to a strong heat. In this manner sulphur is produced in large quantities for useful purposes from iron pyrite $\text{FeS}_2 = \text{FeS} + \text{S}$. These supersulphides combine with other metall

sulphides to produce compound salts. The theory of such salts has not yet been made particularly clear. I am inclined to think that sulphur produces, with certain metals, compounds that are equivalent to the amidogen and ammonium which hydrogen produces with nitrogen; that, for example, there are such compounds as MS^2 , and MS^4 , which act as radicals in salts; and that the powers of these compounds vary according to the nature of the metals with which the sulphur is combined, those containing alcalifiable metals producing basic radicals, and those containing acidifiable metals producing acid radicals. According to this view, the pentasulphide of potassium = KS^5 would be a salt = $KS^4 + S$, and the pentasulphide of arsenic AsS^5 would become $AsS^4 + S$. This last salt produces numerous double salts by combining with monosulphide of potassium = KS . Thus, we find the following:—

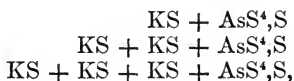

and extending, in the reverse direction, to

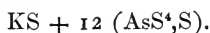

A few other examples of these compound sulphides will be quoted among the salts of the metals; but I have not space to develop this speculation fully.

The sulphides formed by the metals of the alcalies are all soluble in water. Their colour is yellowish or brownish white. Some of them combine with water and produce crystals. The sulphides of the metals of the alkaline earths are also soluble in water; but the sulphides of barium and strontium are more readily dissolved than the sulphide of calcium. The solutions of these sulphides give a blue colour to red litmus paper. The solutions of the alkaline protosulphides are colourless, but they become yellow in the air, like the solutions of the persulphides. These solutions are all readily decomposed by other acids; the mixture discharging sulphuretted hydrogen gas, and retaining a metallic salt. Thus: $KS + HSO^2 = HS + KSO^2$. The metals of the non-alkaline earths can scarcely be said to produce sulphides; for when sulphide of ammonium is added to solutions of their salts, the base (for example, alumina) precipitates in the state of hydrated oxide, a salt of ammonia remains in solution, and HS is discharged as gas:—

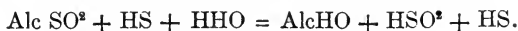

A great many of the heavy metals produce sulphides that are insoluble in water, and possess very characteristic colours. Upon these last-named properties depends the use of sulphuretted hydrogen as a chemical test.

Detection of Sulphides.—See page 93.

PRECIPITATION OF METALLIC SULPHIDES.—The great importance of sulphuretted hydrogen and sulphide of ammonium, as means of detecting and separating many of the metals in analytical operations, induces me to give the following tables explanatory of their reactions:—

ACTION OF SULPHURETTED HYDROGEN.

Applied either as Gas or in Aqueous Solution.

The mark (!) signifies that the action takes place only with salts of particular acids, or under peculiar circumstances.

Not Precipitable.	Metals Precipitable, and from what Solutions.		
	Acid Solutions.	Neutral Solutions.	Alcaline Solutions.
Potassium.		! Manganese.	Manganese.
Sodium.		! Zinc.	Zinc.
Lithium.	Cadmium.	Cadmium.	Cadmium.
Ammonium.		! Iron.	Iron.
—		! Nickel.	Nickel.
Barium.		! Cobalt.	Cobalt.
Strontium.	! Lead.	Lead.	Lead.
Calcium.	Tin.	Tin.	! Tin.
Magnesium.	Bismuth.	Bismuth.	Bismuth.
—	Copper.	Copper.	Copper.
Glucinum.	Silver.	Silver.	Silver.
Yttrium.	Mercury.	Mercury.	! Mercury.
Aluminum.	Palladium.	Palladium.	! Palladium.
Zirconium.	Platinum.	Platinum.	
Thorium.	Rhodium.	Rhodium.	Rhodium.
—	Iridium.	Iridium.	
Cerium.	Gold.	Gold.	
Uranium.	Osmium.	Osmium.	Osmium.
! Silicon.	Tellurium.	Tellurium.	
Titanium.	Antimony.	Antimony.	
Tantalum.	! Tungsten.	(Tungsten.)	
! Chromium.	Molybdenum	Molybdenum.	
	Arsenic.	! Arsenic.	
	(Selenium.)	(Selenium.)	
	Vanadium.		Uranium.

ACTION OF SULPHIDE OF AMMONIUM.

Not Precipitable.	Precipitable as Oxides.	Precipitable as Sulphides.	
		Insoluble in excess.	Soluble in excess.
Potassium.	Glucium.	Manganese.	! Tin.
Sodium.	Yttrium.	Zinc.	! Mercury.
Lithium.	Aluminum.	Cadmium.	! Platinum.
Ammonium.	Zirconium.	Iron.	! Iridium.
—	Thorium.	Nickel.	! Gold.
Barium.	Cerium.	Cobalt.	Tellurium.
Strontium.	! Silicon.	Lead.	! Antimony.
Calcium.	Titanium.	! Tin.	Tungstenum.
! Magnesium.	Tantalum.	Bismuth.	Molybdenum.
	Chromium.	Copper.	! Vanadium.
		Silver.	Arsenic.
		! Mercury.	(Selenium.)
		Palladium.	
		Rhodium.	
		Osmium.	
		! Antimony.	
		Uranium.	

METALS INDICATED BY THE COLOURS OF THE PRECIPITATED SULPHIDES.

BLACK, BROWNISH BLACK, AND DARK BROWN—

Silver.	Bismuth.	Platinum.
Copper.	Nickel.	Palladium.
Mercurous salts.	Cobalt.	Iridium.
Mercuric salts.	Tin, stannous salts.	Rhodium.
Iron.	Uranium.	Tellurium.
Lead.	Molybdenum.	Gold.

WHITE—

Zinc.	Zirconia.	Mercury.
Manganese.	Thorina.	Iron, ferric salts.
Alumina.	Cerium.	Titanic acid.
Glucina.	Silica.	Tantalac acid.
Yttria.	(Sulphur.)	(See page 626.)

GREEN	Chromium.
FLESH RED	Manganese.
PALE YELLOW	Tin, stannic salts.
LEMON YELLOW	Arsenic. Cadmium. Selenium.
ORANGE	Antimony.
REDDISH BROWN	Mercury. Lead.
YELLOWISH BROWN	Osmium.
LIGHT BROWN	Tungsten.

SULPHIDE OF CARBON. XANTH.

Formula, CS²; Equivalent, 76; Specific gravity of gas, 38; Atomic measure, 2 volumes; Atomic measure in gaseous salts, 0; Specific gravity in the liquid state, 1.272. Synonymes: Sulphocarbonic Acid; Bisulphide of Carbon, so called by those who make the atomic weight of carbon = 6. It appears to act in the salts called Xanthates as a compound radical, and in that state may be called *Xanth*.

Properties.—A colourless, very thin liquid, of peculiar and disagreeable odour, resembling that of rotten cabbage. Its sp. gr. is 1.272. It is insoluble, and sinks in water. Extremely volatile; boils at 118° F. Its evaporation produces a great degree of cold. The sp. gr. of its gas is 38. It is readily combustible, and burns with a blue flame, producing carbonic acid and sulphurous acid. It acts as an acid towards metallic sulphides, producing complex double salts. It is soluble in alcohol, ether, and oils. It dissolves sulphur and phosphorus, and the solutions, by spontaneous evaporation, yield crystals of these elements. It also dissolves many organic substances, as camphor, amber, mastic caoutchouc, volatile oils, and resins, and may be useful in the preparation and use of resinous varnishes, the rapidity with which it evaporates being highly useful in particular circumstances.

Preparation.—1. Sulphide of carbon is produced when gaseous sulphur is brought into contact with red-hot charcoal. The following is the apparatus used for its preparation by Mitscherlich. An iron tube, *b c*

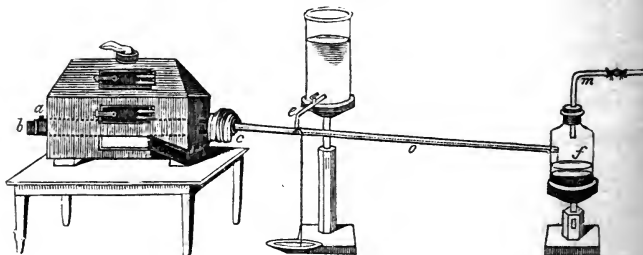

three feet long and two inches in diameter, is placed through an oblong portable furnace, in which it can be made thoroughly red-hot. This tube is filled with pieces of charcoal, previously dried by ignition in a closed crucible. The end *b* is stopped by a cork. At *a* is a small hole, which can also be effectually closed by a cork. The end *c* is adapted, by means of a cork, to a very long glass tube, *o*. All the corks must be previously boiled in glue, to make them fit air-tight. The long tube passes, air-tight, through a hole or a side-neck, into the flask *f*. The tube *m*, fastened by a cork into the flask *f*, serves to carry off superfluous gases through a window or into a good-drawing chimney. A little water is placed in the flask. The tube *o* must be well cooled by a stream of ice-cold water *e*. [The cooling power represented in the figure would not be sufficient. The cold water must affect the whole length of the tube. See pages 237 to 242, and 299, 300.] The end of the tube *o* is not allowed to dip into the liquor in the flask *f*, in order that there may be no pressure produced to retard the distillation. When the charcoal in the tube is considered to be red-hot, small pieces of sulphur are from time to time inserted at the hole *a*, the stopper of which is always instantly replaced. The sulphur melts, runs down to the hot part of the tube (which is, for that purpose slightly inclined from *b* to *c*), and is there vapourised. The red-hot charcoal absorbs the gaseous sulphur, and produces sulphide of carbon, which, being volatile, is driven by the heat into the tube *o*, where it is condensed into a liquid, which flows into the flask *f*, and sinks below the water. If the cooling is not effective, the sulphide of carbon escapes in vapour by the tube *m*. The charcoal, notwithstanding its previous ignition, always retains a little hydrogen, which combines with a portion of sulphur, and produces sulphuretted hydrogen gas, which escapes by the tube, *m*. The operation is continued as long as sulphide of carbon continues to be produced. The product always contains an excess of sulphur. It is purified by distillation from a retort heated by a water-bath. The operation must proceed very slowly. As sulphide of carbon boils at 118° F., the heat must be supplied very cautiously. The receiver *b* must be very effectively cooled by iced water, the junctions between the adapter *a*, and the retort and receiver, must be securely made with good corks. When nine-tenths of the sulphide of carbon has passed into the receiver, the residue in the retort will retain the excess of sulphur. If it is permitted to evaporate spontaneously in a covered capsule, fine crystals of sulphur will be obtained.



475.

Sulphide of Carbon should be preserved in a well-stoppered glass bottle, with an inch or more of water above it, to prevent evaporation.

2. When a large quantity of sulphide of carbon is required it can be prepared by an apparatus fitted up as follows: Fig. 476 represents a large retort made of stoneware, and having a very long tubulure. To



476.

this tubulure a tube of stoneware or porcelain is luted with clay in such a manner that it nearly touches the bottom of the retort inside. The retort is filled with fragments of charcoal, fixed in a table furnace, adapted to a good condensing apparatus, such as fig. 243, page 241, or fig. 248, page 242 and strongly heated. Bits of sulphur are then inserted one by one into the porcelain tube, which is immediately after each addition closed with a good cork. The production, distillation, and condensation of

the sulphide of carbon then proceeds as described in the preceding process.

EXPERIMENTS WITH SULPHIDE OF CARBON.

1. Fill a glass cylinder, about eighteen inches high, and three or four inches in diameter, with nitric oxide gas (page 289). The mouth of the cylinder should be ground, and covered with a ground and greased glass plate. Place the cylinder mouth upwards, on the table. Lift the glass plate and quickly sprinkle in the cylinder, by means of a pipette, five or six septems of liquid sulphide of carbon. Immediately replace the glass cover, and

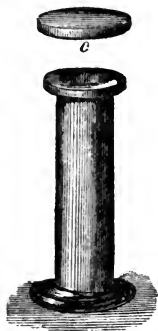

477.

invert the jar a few times to diffuse the vapour of sulphide of carbon through the nitrous gas. Replace the cylinder on the table in such a manner that the mouth of it does not point to any spectator. Lift the cover and immediately inflame the gas. It burns without explosion, or with only a slight noise, but it gives a splendid blue flame, which rises high above the cylinder, while the whole interior of the glass becomes coated with precipitated sulphur. The gases produced by this combination are sulphurous acid

carbonic acid, and nitrogen.

2. Take a cylinder of japanned tinplate, twelve inches long and two inches in diameter. Fill it with pure oxygen gas, and mix with the gas four or five septems of liquid sulphide of carbon, in the manner described in experiment 1, and cover the mouth of the jar with the palm of your left hand. Have ready an iron wire of the thickness of a knitting needle, and eighteen inches long, bent at a right angle in the middle, and heated strongly at one end, but not made red-hot. Re

move your left hand from the mouth of the jar, seize the jar outside, and turn its mouth away from your face. Immediately plunge the hot end of the wire into the gas so far as to reach to about the middle of the cylinder. There occurs almost immediately a very powerful detonation, which, however, is without danger if the above precautions are observed. The gaseous products of this combustion are sulphurous acid and carbonic acid.

3. *Caoutchouc Cement, useful as a Lute and Varnish for Chemical Apparatus.*—Cut a caoutchouc bottle into very small fragments. Fill a wide-mouthed bottle with two-thirds of mineral naphtha and one-third of cut caoutchouc. Close the bottle and let it remain undisturbed eight or ten days in a warm place. By that time the pieces of caoutchouc will be greatly swelled. Pour off the remaining mineral naphtha, and add in its place a mixture of equal parts of sulphuric ether and sulphide of carbon. The mixture is to be frequently well shaken for some days, and finally left for some time in repose. When the contents of the bottle form two distinct liquors, the uppermost clear, thick liquor is to be poured off for use into another vessel, which must be securely stoppered. This cement can be coloured by powdered gamboge, carmine, or other pigments.



478.

Cracks in glass tubes, retorts, and other vessels, can be rapidly stopped by this cement, for the solvent is so volatile that it flies off immediately, and the caoutchouc forms a thin, tough, dry skin. It serves in many cases to make air-tight junctions, or to cover the corked mouth of a bottle in which a preparation is to be secured from air.—*Boettger.*

4. Set fire to a little sulphide of carbon contained in a porcelain capsule. A brush of fine steel wire will burn in this flame, proving the intensity of its heat.

5. Cover the ball of a thermometer with cotton wool moistened with sulphide of carbon, and wave the thermometer in the air. The evaporation thus produced will cause the mercury to sink a great number of degrees.

6. One drop of sulphide of carbon vapourised in six cubic inches of air is exploded by an electric spark in the air pistol. Page 206.

XANTHATES.—A considerable number of salts are related, more or less intimately, to sulphide of carbon. I have given a full account of their constitution, as far as it is understood, in my work on the Radical Theory. The formulæ and names which have been applied to them are extremely numerous, and in many cases curious from their oddness. But since the salts have only a theoretical interest, and are without practical importance, I will pass them over.

THE SULPHOCYANIDES.

Formula, $MCyS^2 = MS + CyS$.

I give to the sulphocyanides a formula which intimates that they are to be looked upon as double sulphides, consisting of a sulphide of cyanogen combined with a basic sulphide. But the common formula attributed to them is $M + CyS^2$; in which case the elements CyS^2 or $CNSS$ are considered as forming a peculiar salt radical. I do not find any experimental evidence to prove the separate existence of such a radical; but it certainly *may* exist, for it has much of the character of those acidic bisulphides which I have compared at page 623 with amidogen. It deserves, however, to be borne in mind that the formula is susceptible of another variation, namely, $MS^2 + Cy$; which represents a cyanide of a basic bisulphide. Upon the whole, the formula $MS + CyS$ is preferable to the others.

Hydrosulphocyanic Acid = $HS + CyS = HCyS^2$.—Dissolve sulphocyanide of potassium in a small quantity of water, add a concentrated solution of phosphoric acid, and distil the mixture. The product is a concentrated solution of hydrosulphocyanic acid in water. It is colourless, odorous, strongly acid, of sp. gr. 1.022; it boils at 217° F., and freezes at 14° F. With metallic oxides, it forms—

Sulphocyanides = $MCyS^2 = MS + CyS$.—These salts are nearly all soluble in water, producing colourless solutions. Their most striking character is, that with solutions containing ferric salts they produce a deep intense blood-red colour. Hence, a solution of sulphocyanide of potassium is the most delicate test for the presence of iron. A solution of nitrate of silver gives a white precipitate of sulphocyanide of silver which is insoluble both in nitric acid and in ammonia.

Sulphocyanide of Potassium = $KCyS^2$.—This salt, which may be adduced as the best example of the series, is prepared as follows: Calcine in a covered crucible, at a dull red heat, an intimate mixture of 2 parts of dried yellow prussiate of potash, 2 parts of sublimed sulphur and 1 part of carbonate of potash. Let the fused mass cool, and then treat it with boiling water. Filter and evaporate the filtered liquor. When it cools, prismatic crystals of sulphocyanide of potassium will be produced. The crystals can be purified by solution and recrystallisation from alcohol.

Theory.—Yellow prussiate of potash is $KKFe, Cy^3$. The potash and the carbonate of potash throws out the iron in the state of oxide, while CO^2 escapes as gas. The cyanogen and potassium thus set free combine with the sulphur, to produce the double sulphide $KS + CyS$.

Among the basic radicals which produce sulphocyanides are hydrogen; metallic radicals, both of the basylous and basylic states; hydrocarbons, and ammoniums, simple and compound. The sulphocyanides occur, single, double, and triple.

6. SELENIUM.

Symbol, Se. Equivalent, 40; Specific gravity in the solid state, 4.8.

Selenium is solid, brittle, and of shelly fracture. Its sp. gr. is 4.8. It has a metallic splendour; its colour is black or dark grey; it is opaque. Thin slips have a red colour, and are transparent; the fine powder is dark red. It readily fuses; heated and protected from air, it boils and produces a dark-yellow gas. It burns in the air with a blue flame, and diffuses a powerful odour of decayed horse-radish. It dissolves when heated in nitric acid or aqua regia, and produces selenious acid.

Compounds of Selenium.—They very much resemble those of sulphur. With oxygen, it forms selenious acid; with hydrogen, it forms seleniuretted hydrogen; with oxygen and hydrogen jointly, it forms selenic acid; with oxygen and metals jointly, it forms seleniates, which are very similar to sulphates; with metals, it forms selenides. The compounds of selenium are equivalent to those of sulphur, excepting that every atom of the latter is replaced by an atom of the former. Selenium is extremely rare: it occurs in the mineral called selenide of lead = $PbSe$, and in the refuse of a particular sulphuric acid manufactory near Fahlun.

Selenious Acid.

Formula, SeO ; Equivalent, 56; Specific gravity of gas, 56; Atomic measure, 1 volume; Systematic name, Selate.

Preparation.—Arrange the apparatus represented by fig. 479. Put

a fragment of selenium into the tube $a b c$, so as to rest at the elbow b . Pass oxygen gas from the retort through the apparatus. Then apply a spirit lamp to the bend of the tube. The selenium takes fire and burns with a blue flame, and selenious acid condenses in the upper part of the tube c , in white crystalline needles. The acid is soluble in water, and forms with basic radicals a variety of salts, the selenites = $MSeO + MSeO^2$, which closely resemble the sulphites.

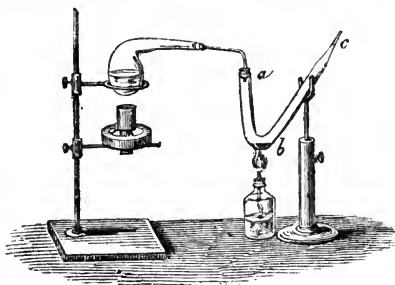

479.

*Selenic Acid.**Formula, HSeO²; Equivalent, 73.*

The seleniates agree with the formula $MSeO^2$. They resemble the sulphates. Seleniate of potash is produced by deflagrating selenium or a selenite with nitre. The product of the deflagration is dissolved in water and mixed with a solution of nitrate of lead, which precipitates seleniate of lead. If this salt is suspended in water and decomposed by sulphide of hydrogen, we obtain sulphide of lead and hydrated selenic acid:—

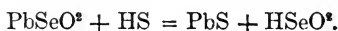

The seleniates are produced by saturating this acid with metallic hydrates:—

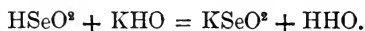

All the salts of selenium when decomposed on charcoal before the blowpipe, produce the odour of horse-radish by which selenium is characterised.

Hydroselenic Acid, Seleniuretted Hydrogen, Selenide of Hydrogen.

Formula, HSe; Equivalent, 41; Specific gravity of gas, 41; Atomic measure, 1 volume. Systematic name, Hydra sela.

Prepared in the same way as hydrosulphuric acid. A colourless gas, of most offensive odour, and very poisonous.

All the compounds of selenium nearly resemble those of sulphur, but the scarcity of this element renders them of little importance.

TELLURIUM.

7. THE TELLUROUS RADICAL, $Te = 64$.8. THE TELLURIC RADICAL, $Tec = 32$.

Tellurium is an element which has some of the properties of a metal, but on the whole such as agree better with those of sulphur and selenium. Very rare. Its ores are found only in Hungary and Transylvania.

The radical Te produces tellurous salts, such as HTe , a gas, sp. gr. and equivalent both = 65; $TeCl$ = tellurous chloride. H,TeO^2 = hydrated telluric acid; Te,TeO^3 , telluric anhydride. In this case, the ordinary names indicate the composition erroneously. The radical Tec produces telluric salts; $TecCl$ = telluric chloride; $Tec,TecO$ = tellurous oxide (again a contradiction in terms); $TecS$ = telluric sulphide. The proposed systematic nomenclature would avoid such vague and erroneous names as the above.

HTe = Hydra tellurous.
 $TeCl$ = Tellurous chlora.
 $TecCl$ = Telluric chlora.
 $TecS$ = Telluric sulpha.

$Tec,TecO$ = Telluric telluricate.
 Te,TeO^3 = Tellurous tellurousite.
 $HTeO^2$ = Hydra tellurousete.

9. PHOSPHORUS.

Symbol, P; Equivalent, 31; Specific gravity of gas, 62; Atomic measure when isolated, $\frac{1}{2}$ volume; Atomic measure when acting as an acid radical in salts, $\frac{1}{2}$ volume; its condensing power on other radicals with which it combines to form gases, is the reduction of every volume to half a volume.

Occurrence in Nature.—See page 12. The phosphorus which is required for scientific and technological purposes is derived entirely from the bones of animals.

Preparation.—Phosphorus is prepared by distilling a mixture of burnt bones and charcoal. The operation is too troublesome and dangerous to be undertaken by unpractised students. The method is as follows:—Mix 3 parts of white burnt bones with 20 parts of water and two parts of oil of vitriol, and put the mixture to digest in a warm place for 24 hours. It will then contain sulphate of lime and superphosphate of lime. Add 50 parts of water, which dissolves only the superphosphate. Strain to separate the sulphate of lime, and evaporate in an iron pot, till the mixture forms a jelly. Then add as much powdered charcoal as is equal in weight to one-fourth of the bones used. Stir the mixture thoroughly, and heat it gradually till red-hot.

It is then to be immediately put into a stoneware retort, *a*, fig. 480, the neck of which is adapted to a wide tube of copper, *b*, whose other end dips about a quarter of an inch only into cold water. Heat is to be applied to the retort and gradually increased, upon which the phosphorus distils over into the water. In the retort, there remains neutral phosphate of lime. A safety-tube is added to the flask, to allow the escape of various incondensable inflammable gases that are produced in the distillation. The phosphorus thus obtained is cut under water into small pieces, put into a

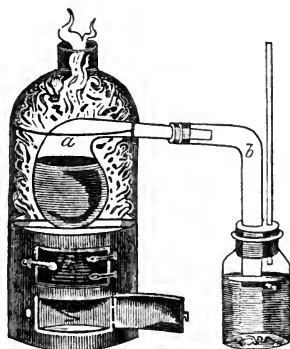

480.

glass tube that is corked at the bottom, and the upper end of which is funnel-shaped. Cold water is added, and the tube is then plunged into warm water, when the phosphorus melts and fills the narrow part of the tube, while the water and impurities rise to the surface. The tube is

then put into cold water, when the phosphorus becomes solid. The cork is removed, the phosphorus pushed out of the tube, and the impurities cut off.—Phosphorus can be purchased for experiments in sticks like those of caustic potash. These must be preserved in water, in a bottle corked, and placed in a dark and cool situation. Phosphorus requires to be handled with much caution, because the heat of the hand inflames it, and it causes very painful wounds.

Distillation of Phosphorus.—Since phosphorus is fusible at a very low temperature, and volatile without change, it can be readily distilled in vessels of glass, but the distillation necessarily demands particular care, because of the extreme combustibility of phosphorus. The apparatus represented by fig. 481 can be used for this experiment. The phosphorus to be distilled is put into the retort A. The receiver, *a, b, c,* must be of a large size, in proportion to the retort, and must have a little water at *b,* enough to cover the bend, but not enough quite to fill either of the two branches of the tube, *a b* or *b c.* When the retort is heated, the air forces the water to rise into the branch *b c,* and then passes through it in bubbles. After that the phosphorus passes

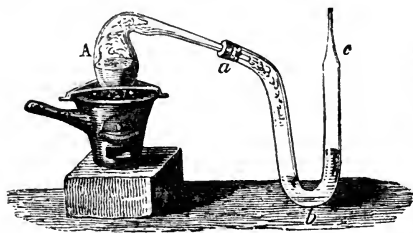

481.

over into the tube, and condenses under the water in a liquid state as long as the temperature remains above 104° . When the distillation ceases, or even slackens, a vacuum forms in the retort. The atmospheric air then begins to press at *c* upon the liquor in the bend *b*; the liquor rises in the branch *a b,* and the air rises through it in bubbles to supply the vacuum in the retort A. If the branches of the tube were not made large enough for this play of the water and air, the water would be driven back into the hot retort and might break it with explosion; and if the liquid phosphorus were driven back with the water into the retort, the result of that explosion might be very dangerous indeed, both to the operator and to his house. The utmost caution should be used to avert so fearful a disaster.

To render Phosphorus Colourless and Transparent without Distillation—A concentrated solution of bichromate of potash is mixed with sulphuric acid, and in this mixture the yellow or reddish opaque phosphorus is melted. The bottle is then to be closed and violently shaken, for the purpose of dividing the phosphorus and bringing it into contact with the solution. The phosphorus falls into minute balls which, when left quiet, again unite and form a liquid, which even retain the liquid form after cooling, until it is touched by some solid body

upon which it immediately congeals. Phosphorus can also be purified by being melted under water that contains ammonia or caustic potash.

Properties.—Phosphorus, at the ordinary temperature of the air, is solid, of a yellow colour, transparent, flexible like wax, and heavier than water. Its specific gravity is 1.83. It melts upon being gently heated, at 113° F., or when warm water is poured upon it. If excluded from air, and exposed to a higher temperature, it volatilises, and can be distilled at 572° F. Its gas is colourless. It is insoluble in water, but dissolves in oils, alcohol, ether, naphtha, and sulphide of carbon. It crystallises in rhombic dodecahedrons.

In the presence of air, phosphorus readily inflames; a gentle friction is sufficient to cause its combustion. In hot weather it often inflames spontaneously, especially if exposed to the air upon rough bodies, such as coarse blotting-paper. It burns with a bright flame, and produces a thick white smoke. It gives light in darkness; and this light is most powerfully produced when a stick of phosphorus is placed in nitric acid, in such a manner that a portion projects above the liquid. It diffuses white vapours in the air. When kept in vessels exposed to light, it acquires an opaque brown coating of oxide or of amorphous phosphorus, even though immersed in water. Its odour is peculiar, but somewhat resembles that of garlic. It is poisonous.

Nitric acid and aqua regia easily dissolve phosphorus, and produce phosphoric acid. Hydrochloric acid does not dissolve phosphorus. If chlorine gas is passed over heated phosphorus, it produces a solid or a liquid chloride of phosphorus, according as more or less chlorine is employed. In a solution of pure potash, phosphorus dissolves under disengagement of spontaneously inflammable phosphuretted hydrogen gas.

Amorphous Phosphorus.—This substance is pure phosphorus possessed of properties quite different from those of common phosphorus. It is a brownish-red powder. When exposed to the air it emits no light, nor smoke, nor odour. It is insoluble in sulphide of carbon and in naphtha. Its specific gravity is 2.14. It may be heated in the open air to any degree under 500° F. without taking fire, but at 500° it changes into common phosphorus, and melts and burns like common phosphorus. If it is heated in a close tube free from air it is still converted at that temperature into common phosphorus. The amorphous phosphorus is prepared by heating ordinary phosphorus in a glass vessel, in an atmosphere of carbonic acid gas for several hours at a temperature of about 450° or 460° F. It may be prepared in an imperfect manner by experiments 9 and 10 in the following collection.

EXPERIMENTS WITH PHOSPHORUS.

In all experiments with this substance, the greatest degree of care is required, on account of its very combustible nature. A very small

portion of it (the quantity is generally mentioned in the experiment) should be operated upon at once. When it is taken in the hands, it never should be held for more than a few seconds, for the heat thus applied is sufficient to inflame it, and a burn from phosphorus is more painful than any other kind of burn. It is better always to handle it with pincers. A basin of cold water ought always to be at hand, to dip the phosphorus in occasionally; and when it is cut in pieces it must be cut under water. Phosphorus can only be preserved by keeping it in places where neither light, nor air, nor heat has access. It is purchased in rolls about the thickness of a quill; these should be put into a phial filled with cold water, that has been previously boiled to expel air from it, and the phial should be inclosed in an opaque case. Experiments made with phosphorus create a very disagreeable odour in the house where the operations are carried on.

When a bit of phosphorus is required for an experiment, a stick should be lifted out of the bottle with pincers, laid in a flat dish containing water, and the required quantity be cut off with scissors or knife. The stick should be immediately returned to its water-bottle. The bit may be dried by gentle pressure (not by friction) on filtering-paper.

1. *Fusion of Phosphorus.*—Into a glass tube half filled with warm water, put a small piece of phosphorus; it sinks to the bottom of the water and melts. It does not burn because cut off from air, and it cannot, like potassium, decompose water.

2. *To show the Inflammable nature of Phosphorus.*—1. Wrap a grain of it, dried on blotting-paper, in a piece of brown paper, and rub it with some hard body; it will set fire to the paper. 2. Put into the middle of some dry cotton, a piece of phosphorus the size of a large pin's head (previously dried as before); strike it with a hammer and it will inflame. 3. Upon a piece of glass, lay a small piece of phosphorus and place the glass upon a cork on the surface of hot water in a basin; the phosphorus will inflame. 4. If a chip of dried phosphorus be brought into contact with iodine on a watch glass, inflammation instantly ensues. 5. When oxide of copper is heated with phosphorus in a glass tube over a spirit-lamp, a vivid combustion, attended by a green flame, is produced.

3. *Preparation of Phosphorised Ether.*—Suffer sulphuric ether to stand for some time over a few grains of phosphorus in a well-stoppered phial. The solution is aided by occasional agitation.

4. *Preparation of Phosphorised Oil.*—Put one part of phosphorus with six parts of olive oil into a Florence flask, and digest the mixture in a gentle sand heat for two hours. The solution must be kept in a dark place.

5. *To make Waves of Fire on the surface of Water.*—On a lump of loaf-sugar, let fall a few drops of phosphorised ether, and place the

sugar in a glass of warm water; a very beautiful appearance will be instantly exhibited, and the effect is increased if the surface of the water is made to undulate, by blowing gently with the breath.

6. *To make the Face and Hands Luminous, so that, in the dark, they appear as if on Fire.*—Though the phosphorised oil and ether are luminous in the dark, yet they have not the power to burn anything; so that either of them may be rubbed on the face and hands without danger; and the appearance thereby produced is hideously frightful. All the parts of the face that have been rubbed, appear to be covered with a luminous bluish flame, and the mouth and eyes appear as black spots. The light is stronger if the hands are rubbed to expose new surfaces of phosphorus. When the bottles containing phosphorised oil and ether are opened in the dark, light enough to tell the hour on a watch is evolved.

7. *Combustion of Phosphorus in Oxygen Gas.*—See page 185.

8. *Writing which is luminous in the dark.*—Trace letters or figures on a smooth board, or on dark coloured paper, with a stick of phosphorus, in the same manner as you would trace them with a crayon. Every line thus made will be beautifully luminous in the dark, and will continue so for some minutes. The luminous appearance of the writing arises from a slow combustion of the phosphorus which adheres to the board.

9. *Brilliant Combustion under Water. Production of Amorphous Phosphorus.*—Drop a piece of phosphorus, of the size of a small pea, into a deep glass containing a little cold water, and add a good quantity of hot water, which will melt the phosphorus but not inflame it. Then force upon it, from a bladder with a jet pipe fitted to it, a stream of oxygen gas. Upon this, there will be produced a flame of great vividness below the water. Phosphoric acid is formed, and dissolves in the water; but solid red flocks which remain undissolved, consist chiefly of amorphous phosphorus. It is uncertain whether or not it also contains an oxide of phosphorus.



482.

10. *Amorphous Phosphorus.*—Into a glass tube, three feet long and half an inch wide, put, at about six inches from one end, a piece of phosphorus of the size of a pea. Melt the phosphorus by holding a spirit-lamp below. Then blow suddenly and strongly into the tube, applying your mouth to that end near which the phosphorus is placed, upon which a large flame is produced, and the whole tube becomes coated with a red powder, which chiefly consists of amorphous phosphorus. *This experiment is very dangerous to a careless experimenter.* If you suck air from the tube, instead of blowing air into it, you will be seriously burnt.

11. *To show the different Solubility of the two kinds of Phosphorus in Sulphide of Carbon.*—Put small bits of each kind of phosphorus into

separate small quantities of sulphide of carbon. Wet two pieces of filtering paper with the two solutions. The sulphide of carbon speedily evaporates, and one of the pieces of paper takes fire, but not the one prepared with amorphous phosphorus.

12. *Preparation of Phosphorus for the Instantaneous production of Light.*—Put a little phosphorus, dried on blotting-paper, into a small phial; heat the phial by placing it in a ladle full of hot sand, and turn it round, so that the melted phosphorus may adhere to its sides. Cork the phial closely, and it is prepared. Another method of preparing it consists in mixing one part of flowers of sulphur with eight parts of phosphorus. On putting a common sulphur match into this fire-bottle, stirring it about a little, and then withdrawing it into the air, it will take fire. Sometimes, however, it is found necessary to rub the match, when withdrawn from the phial, on a cork, before it will inflame.

13. *Matches that take Fire without Explosion when rubbed.*—The matches that inflame with explosion always contain chlorate of potash. Those which take fire quietly are free from that salt. Since the manufacture of matches with chlorate of potash is always attended with danger, it is advisable, if possible, to dispense with the use of it.

The best mixture for the preparation of a combustible substance, adapted to burn without explosion, when fixed upon wood, papers, German tinder, &c., is as follows:—Take, gum arabic, 16 parts by weight; phosphorus, 9 parts; nitre, free from deliquescent chlorides, 14 parts; peroxide of manganese in very fine powder, 16 parts.

Red lead may be used instead of manganese, if a red colour is desirable in the inflammable mixture. Gum tragacanth may be advantageously used instead of gum arabic, since 1 part of tragacanth makes as thick a mucilage with 100 parts of water, as 1 part of arabic does with 4 parts of water.

The matches are prepared as follows:—The gum is first made into a strong mucilage with water in an evaporating basin, with the aid of heat. The manganese is first added, and then the phosphorus, previously cut into very small pieces. These must be immediately enveloped by the gum-water. Heat is then applied to melt the phosphorus, but this must be kept below 140° F. When the phosphorus melts, the whole is to be well mixed, and the phosphorus very finely diffused, by means of thorough stirring with a flat spatula. The nitre is then added, and the heating and active stirring are continued until the whole is brought to a uniform paste, and of that degree of consistence which only experience can indicate as the proper working point. At this stage of the operation the particles of phosphorus must no longer be visible to the naked eye.

When the mixture is thus prepared, the wood matches prepared with sulphur, or the paper prepared with nitre, is dipped into it, and then dried in the air.

As it is known that phosphorus slowly becomes oxidised at the expense of the oxygen of the air, and produces phosphorous acid, which greedily absorbs moisture, it is proper to provide against the consequent spoiling of the matches, by giving them, when prepared or dried, a very thin coat of copal varnish, applied by means of a brush. This effectually hinders the spoiling of the matches by damp.

14. The following is a cheaper mixture for the preparation of matches:—Take, phosphorus, 4 parts; nitre, 10 parts; carpenters' glue, 6 parts; red lead, 5 parts; smalt, 2 parts.

The glue is to be soaked 24 hours in a small quantity of water, till it produces a jelly. It is then to be put into a porcelain mortar placed over a hot-plate or sand-bath, the other ingredients are to be added, and the whole is to be thoroughly mixed with a porcelain pestle, at a temperature not higher than 150°F ., till the product is a uniform stiff paste that can be drawn into threads.

15. *Paper Matches that burn without flame.*—The above mixture is put on the end of small rolls of paper, prepared by soaking the paper in a strong solution of nitre, and then drying it.

16. *Paper Matches that burn with flame and produce a scent.*—Dip writing-paper into a solution of benzoic acid. Dry it, cut it into slips, and anoint the ends of the slips with the above-described combustible mixture. Then roll up the slips into matches.

17. *Matches of Wood to burn with flame, prepared without Sulphur.*—The wood must be very dry, the ends of the matches dipped first into melted wax, and then into the melted combustible mixture. These matches take fire when rubbed upon glass paper.—*Böttger.*

18. *Rat Poison.*—Prepared from 9 ounces of water, 8 ounces of rye-meal, and a quarter of an ounce of phosphorus.

PHOSPHORIC ACID.

Phosphoric acid, like nitric and sulphuric acid, occurs in two conditions, namely, in the state of *hydrate* and in that of *anhydride*. These varieties of phosphoric acid are constituted as follows:—

The Hydrate = H_2PO_3 = Hydra phosphite.

The Anhydride = P_2O_5 = Phospha phosphite.

The first of these salts contains one replaceable atom of basic hydrogen, which it can exchange for any other radical whatever. When the replacing radical is of the basic order, whether metallic or non-metallic, the quantity of oxygen in the normal phosphate continues to be O^3 ; but when the replacing radical is of the acid order, the quantity of oxygen in the phosphate becomes O^4 or O^5 , according to the special character of the acid radical by which the hydrogen is replaced, as is explained in the general notice of the anhydrides that has been given at page 295.

According to this view of the constitution of the two varieties of phosphoric acid, the anhydrous compound is not a constituent of the normal or hydrated acid; but an abnormal salt, derived from the normal acid by the expulsion of basic radicals, and resolvable into the normal acid by the reacquisition of basic radicals. One equivalent of the anhydride and one salt formed on the model of water produce two equivalents of the hydrated normal acid:—

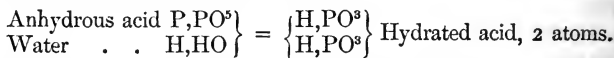

The monobasic phosphates are consequently formed on the model of the hydrated acid = HPO^3 , and have no relation whatever to the anhydrous acid = P, PO^5 , excepting that which is here explained. The phosphates, therefore, never contain anhydrous phosphoric acid.

ANHYDROUS PHOSPHORIC ACID = P, PO^5 .

Preparation.—1. When phosphorus is burnt in oxygen gas, or in common air, it produces a thick white smoke, which, if the gas or air is

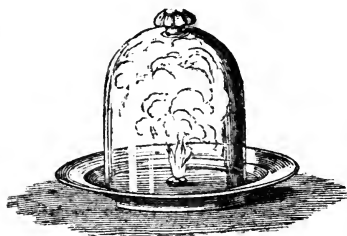

483.

perfectly free from moisture, gradually settles down into a white powder. See pages 185 and 259. This white powder is anhydrous phosphoric acid. To prepare it, take a very large bell jar and a flat capsule, as represented in fig. 483, and make both of them perfectly dry. To accomplish this drying fully, put under the jar on the flat capsule a basin full of lumps of dry quicklime, and suffer it to remain

there for some hours. Then remove the basin of lime, and replace it by a porcelain cup containing a fragment of dried phosphorus, which is to be lighted, and the jar to be immediately put over it. The combustion of the phosphorus continues under the closed jar, until all the oxygen of the air is converted into anhydrous phosphoric acid, which is deposited as a white powder over the whole interior of the apparatus. If the phosphorus was in excess, there remains in the cup a little red matter which may either be amorphous phosphorus or an oxide of phosphorus. The white powder is to be rapidly scraped together with a platinum spatula, and put into a well-dried and well-stoppered glass bottle.

2. *Preparation of the Anhydride by a continuous process.*—The preparation of the phosphoric anhydride, in quantities, by a continuous process, requires an apparatus such as is represented by fig. 484. The vessel in which the phosphorus is burnt is a great glass globe of 20

to 30 pints capacity, with three necks, as represented by A in the figure. It must, of course, be well dried. The cork fitted to the central upper neck is traversed by a tube, *a b*, half an inch in the bore,

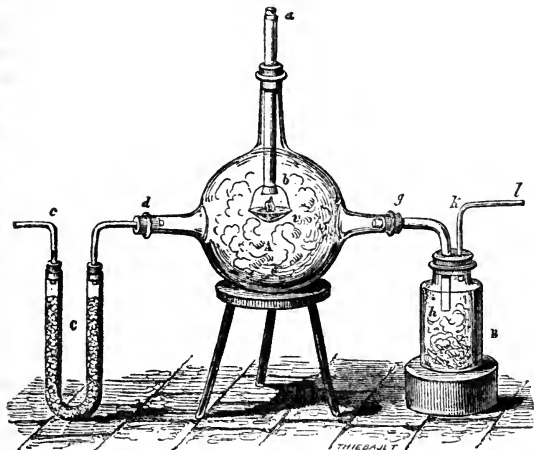

484.

and open at both ends. A small porcelain capsule, *v*, is tied by platinum wires a little below the lower end, *b*, of this tube. To the tubulure on the left hand, *d*, a desiccating tube, C, filled with pieces of pumice-stone saturated with sulphuric acid is attached. The right-hand tubulure, *g*, is connected with a wide glass tube, *g h*, the extremity of which descends into a dried bottle, B, which bottle is placed in communication, by means of the tube *k l*, with an Aspirator (see fig. 343, page 346), capable of drawing air continuously through the apparatus in the direction of *c* to *l*. By this means a supply of fresh dry air is caused to be constantly present in the globe A. The apparatus being thus arranged, a bit of well-dried phosphorus is dropped through the tube *a b* into the cup *v*. It is set on fire by a hot wire passed down the tube *a b*, and the end of the tube *a* is then closed by a cork. The phosphorus burns and combines with the oxygen of the air, and a quantity of phosphoric acid in white powder is deposited in the globe A and in the bottle B. When the first bit of phosphorus is consumed, a second bit is inserted, and so on repeatedly, till enough of the acid is prepared.

Properties of the Phosphoric Anhydride.—A snow-white, flocculent, inodorous powder; fusible at a red heat; volatile at a white heat; deliquescent, and very soluble in water, upon contact with which it hisses like a red-hot iron, disengaging much heat, and producing the normal

hydrated acid ; from which the anhydride cannot again be separated by heat.

HYDRATED PHOSPHORIC ACID = H_3PO_3 .

This is the normal monobasic phosphoric acid containing H^1 replaceable by any basic radical, organic or inorganic, simple or compound.

Preparation.—1. If the solution which is produced by dissolving the anhydride in water is evaporated, it first becomes syrupy, then shows crystals of hydrated acid, and if finally evaporated to dryness, and heated to redness in a platinum capsule, it melts to a transparent colourless fluid, which, if cooled, continues to be transparent, and breaks with a fracture like ice, or pieces of white glass. The constitution of this substance, which, owing to its glassy appearance, is called *glacial phosphoric acid*, is represented by the formula H_3PO_3 . This substance is an intensely sour and energetic acid. It is so extremely deliquescent that it requires to be kept in bottles that are particularly well stoppered, and tied over with caoutchouc.

2. *Preparation of Hydrated Phosphoric Acid, by the solution of Phosphorus in Nitric Acid.*—This experiment requires the apparatus which is represented by fig. 485. Take 1 part of phosphorus, and 13 parts of nitric acid, diluted with water until its specific gravity is reduced below 1.2. The mixture is to be slowly distilled in the retort, and the condenser must be well cooled.

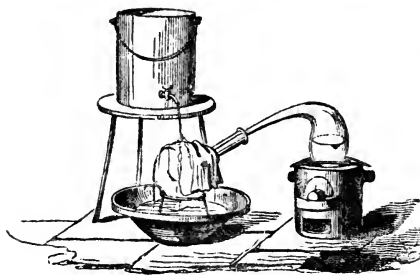

485.

If the acid is denser than 1.2 much gas is disengaged, and if the retort and receiver fit too closely, or the receiver is without an escape-pipe to carry off the gases, a dangerous explosion may occur. But with dilute acid the operation goes on peaceably. The nitric acid which distils over is to be returned to the retort, and again distilled over ; and this repeatedly. Such a mode of operation is called *cobobation*. The phosphoric acid is not volatile, and does not distil over. When the phosphorus is dissolved, the liquor in the retort is boiled till the phosphoric acid becomes syrupy. It is then poured into a platinum capsule, evaporated to dryness, and fused.

3. *Preparation of Hydrated Phosphoric Acid by a continuous process.*—The apparatus is represented by fig. 486. A stone bottle of one gallon capacity, *d*, provided with a stopcock at its lower end, *f*, is filled with water, and connected with a large bottle, *e*, half filled with water, and this

bottle with an inverted funnel *a*, by means of the wide glass tubes *b* and *c*, and the corks *o*, *o*, *o*. The diagram shows the details of the arrangement,

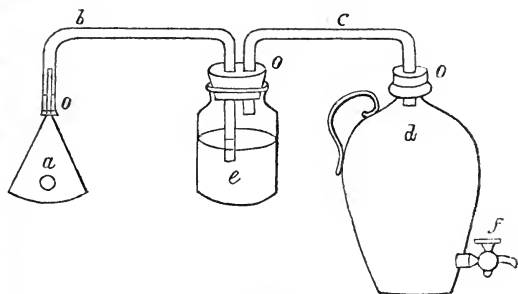

486.

but represents the gallon bottle as too small in proportion to the other figures. The tube *b* should be three-quarters of an inch wide and $2\frac{1}{2}$ feet long. The funnel *a* should have a hole drilled in the side, and an earthen plate should support it below. A piece of dry phosphorus is placed upon the earthen plate, near the hole in the funnel, and is inflamed by a hot iron wire. The stopcock *f* is opened, and as water runs out of the bottle *d*, its place is supplied by air drawn from the rest of the apparatus, and of course in at the hole in the funnel. Hence a current of air passes over the burning phosphorus, and the phosphoric acid which is produced is carried with the air, in the form of snow, into the tube *b*, a portion only of the acid proceeding so far as the flask *e*, in the water of which it dissolves. When the phosphorus first put into the funnel is burnt, a second piece is put in through the hole in the funnel, and is inflamed by the support heated by the combustion of the portion inserted previously. This operation is repeated till the tube *b* is full of phosphoric anhydride, or the jar *d* is exhausted of water.

The dry phosphoric acid in the tube is afterwards dissolved in the water of the flask *e*, and evaporated to dryness in a capsule of platinum. The occurrence of flashes of fire from the concentrating solution indicates the presence of a small portion of phosphorous acid, which, however, can be converted into phosphoric acid, by the addition of a little nitric acid.

4. An impure hydrated phosphoric acid is prepared by digesting at a moderate heat, for several days, a mixture of 3 parts burnt bones, 2 parts oil of vitriol, and 10 parts water. The mixture is to be often stirred, and finally is to be strained from sulphate of lime, made alkaline by ammonia, filtered, and evaporated to dryness. It is this impure acid which is commonly prepared for sale.

THE PHOSPHATES.

I have explained, at page 424, the constitution of the phosphates. There are no less than three kinds, essentially different from one another, namely,—

1. The monobasic phosphates, called also metaphosphates, agreeing with the normal acid HPO^3 .

2. The tribasic phosphates, or common phosphates, which are composed of the monobasic phosphates combined with salts formed on the model of water, namely,



3. The bibasic phosphates, or pyrophosphates, which consist of the first class of phosphates combined with the second class, so as to produce salts in agreement with this formula,—



All these salts are extremely stable; and in consequence of their stability, they exhibit properties which do not belong to other salts, which have the same atomic constitution, but not the same degree of stability.

DETECTION OF PHOSPHATES. See page 94.

COMMON PROPERTIES OF THE PHOSPHATES.—Not volatile, but certain bases can be expelled from them by ignition. Most of them fusible to a glassy mass. Decomposable by sulphuric acid. The phosphates of the alcalies soluble in water; those of other bases insoluble. All of them are soluble in nitric acid, from which solution acetate of lead precipitates phosphate of lead.

Metaphosphates. Formula, MPO^3 .—The solutions are feebly acid. They give, with solutions of chloride of barium and nitrate of silver, white gelatinous precipitates.

Common Phosphates. Tribasic Phosphates. Formula, H^3, PO^4 .—Their solutions give, with salts of lead, a white precipitate, and with nitrate of silver, a lemon-yellow precipitate.

There are three varieties of tribasic phosphates, whose solutions differ in their reactions with test papers, as follows:—

$\text{M H}^2, \text{PO}^4$	Solutions acid.
$\text{M}^2\text{H}, \text{PO}^4$	Solutions feebly alkaline.
M^3, PO^4	Solutions strongly alkaline.

The hydrated phosphoric acid belongs to this class before it is ignited; but the ignited acid or glacial phosphoric acid, is a metaphosphate. H in these phosphates is replaceable either by a basyious or basylic radical.

Pyrophosphates. Bibasic Phosphates.—Formula,



The Pyrophosphates are Phosphates that have been ignited. The neutral salts are slightly alkaline. The acid salts have an acid action. The solutions of both give, with solutions of chloride of barium and nitrate of silver, white pulverulent precipitates.

The characters given to the different orders of phosphates are in some cases founded upon observations made upon individual salts; and a correct understanding of these salts demands an examination of special details, for which the reader must refer to works of greater extent than the present; for example, to Mr. GRAHAM'S *Treatise on Chemistry*, or to his original papers on the Phosphates, published in the *Philosophical Transactions* for 1833. Those papers gave to chemists the first clear series of experimental proofs of the presence of hydrogen in salts as a *basic radical*, in contradistinction to its presence as an ingredient in *water of crystallisation*; a point which, up to that time, all Continental chemists, Berzelius included, had completely ignored. The distinction proved to be of great importance in mineral chemistry, and still greater in organic chemistry.

THE PHOSPHITES.

The phosphites are salts corresponding to hydrated phosphorous acid, the formula of which is HHH,PO^3 , and to anhydrous phosphorous acid, the formula of which is P,PO^3 ; for

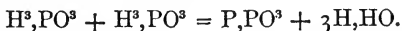

Phosphorous acid, in the anhydrous state, is a white powder, volatile and combustible. In the hydrated state, a thick acid liquor, that gives crystals after slow evaporation. The water cannot be driven off by heat. Prepared as follows:—Put small sticks of phosphorus into a series of glass tubes having a narrow opening at one end, fig. 487, and place these tubes in a funnel adapted to a bottle, fig. 488. Cover the whole with a bell glass, to keep off dust, but not fitting so close as to cut off atmospheric air. A solution of hydrated phosphorous acid gradually accumulates in the bottle. This solution, if long exposed thus to the free access of air, becomes converted into phosphoric acid.



487.



488.

The phosphites = MMM,PO^3 , are of no practical importance.

THE HYPOPHOSPHITES.

The hypophosphites are constituted according to the formula HHM,PO^2 . When phosphorus is boiled in barytic water the products are as follow:—

Potash, 3 atoms = 3KHO }
 Water, 3 atoms = 3HHO } = $3(\text{KH}^2, \text{PO}^2)$ { Hypophosphite of
 Phosphorus, 4 atoms = 4P } { PH^2, H barytes, 3 atoms.
 Phosphide of hydrogen.

The hypophosphites are of no practical importance.

THE PHOSPHIDES OF HYDROGEN.

There are three compounds of phosphorus with hydrogen.

A. Phosphuretted Hydrogen Gas.

Formula, PH^3 , or probably, PH^2, H ; *Equivalent*, 34; *Specific gravity of gas*, 17; *Atomic measure*, 2 volumes.

Phosphuretted hydrogen is a gaseous compound of phosphorus and hydrogen. It is colourless; sp. gr. 17. Its characteristic property is extreme combustibility; it inflames by merely coming into contact with the atmosphere. A brilliant white light attends its inflammation in oxygen gas. When brought into contact with chlorine it detonates with a brilliant green light. It has a disagreeable smell, resembling that of putrid fish, and is poisonous. It combines in a very slight degree with water. It is not acid. Those flashes of light, called by the vulgar *will-of-the-wisp*, and by some *ignes-fatui*, which are often seen in churchyards, and other places where vapours are exhaled from putrifying animal matter, are produced by the formation and inflammation of this gas.

Preparation.—1. A small piece of phosphorus is put into a little retort, which is then filled with a concentrated solution of caustic pot-

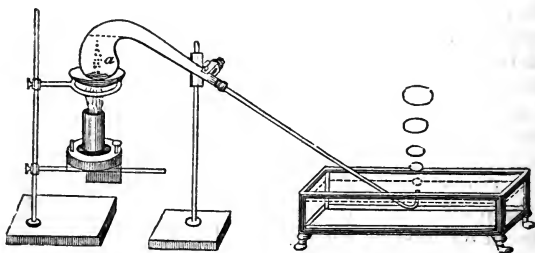

489.

ash, or a milk of lime and water. A long tube is joined to the retort and a very gentle heat is applied by a spirit-lamp. The tube-neck of the retort is made to dip a little way into water contained in a capsule or a little below the surface of the water of a pneumatic trough. When the gas passes over, bubble by bubble, as it rises in the air, it explodes with a small flame, producing elegant wreaths or rings of thick white smoke, which, if the air be tranquil, gradually float away, enlarging in diameter as they go up higher and higher. If a small glass filled with

oxygen gas is held over the mouth of the retort, the bubbles, as they rise and explode in the oxygen gas, produce a light of extraordinary brilliancy.

Experimenting with this gas is not free from danger. Sometimes explosions occur in the retort which smash it to pieces. In particular, the exploding of the gas in oxygen is subject to accident, and ought never to be exhibited without putting a wire safe round the glass containing the oxygen gas. But if the cylinders of oxygen gas contain not above 3 or 4 cubic inches of gas; if the current of phosphuretted hydrogen gas is slow, and each bubble explodes as it rises into the oxygen, there is no danger. This only occurs when a large quantity of the gas explodes at once. To prevent explosions in the retort, you must fill it entirely, tube and all, with the milk of lime, or you may use a gas bottle, fig. 490. After putting in the materials, a match, with a good supply of brimstone upon it, may be burnt in the upper part of

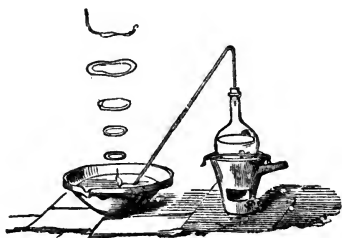

490.

the flask to absorb the free oxygen, after which there is very little danger. The flask should be nearly filled with liquor, and the heat be gentle and regular.

Phosphuretted hydrogen combines with hydriodic acid and produces a gaseous salt of the formula $\text{PH}^3 + \text{HI}$, which has an atomic measure of 4 volumes. It also produces a corresponding salt with hydrobromic acid, formula $\text{PH}^3 + \text{HBr}$; atomic measure, 4 volumes. See page 148. On comparing these facts with what is stated in regard to the salts of ammonia at page 315, we are led to the conclusion that phosphuretted hydrogen is, like ammonia, the hydride of an amidogen = PH^3, H ; which conclusion is strengthened by the recent discovery of salts which greatly resemble salts of ammonium, but which have a basic radical formed in accordance with the formula PH^4 , a formula indicating an ammonium, in which nitrogen is replaced by phosphorus.

2. A second method of exhibiting the production and singular properties of phosphuretted hydrogen gas, is as follows:—Drop a small piece of phosphide of calcium into a wine-glass of water: in a short time bubbles of gas will be produced, which, rising to the surface of the water, will take fire and explode. After each explosion a beautiful column of white smoke will ascend from the glass. If the phosphide of calcium be not fresh made, it may be proper to warm the water it is added to. If the residue of the phosphide of calcium be dried, and have hydrochloric acid poured upon it, it will inflame.



491.

3. Put into a glass (fig. 492) one part of chlorate of potash and two parts of phosphide of calcium, in pieces about the size of peas (not in powder), or instead of the phosphide of calcium use a few small pieces of phosphorus the size of canary seeds. Fill the glass with water, and put into it a tube funnel that will reach to the bottom (fig. 493). Pour through this funnel six or eight parts of strong sulphuric acid, upon which flashes of fire will dart from the surface of the fluid, and the bottom of the vessel be illuminated by a beautiful green light.

B. *Liquid Phosphide of Hydrogen.* Formula, PH^2 .—This seems to be the radical which forms part of the gaseous phosphide PH^2, H . It is prepared by condensing in a U-tube the gas that is disengaged by the action of water upon phosphide of calcium; free oxygen being excluded. The condensing-tube must be cooled with a freezing mixture of ice and salt. It forms a colourless liquid. The instant it comes into contact with free oxygen it burns with the brilliant white light of phosphorus. A little of its vapour diffused in hydrogen, carbonic oxide, or other combustible gas, gives to it the property of taking fire spontaneously in oxygen or atmospheric air; and since phosphuretted hydrogen gas is sometimes produced which is without the power of spontaneous inflammation, it is presumed that in all cases it owes that power to the presence of a small quantity of the radical PH^2 .

C. *Solid Phosphide of Hydrogen.*—Formula said to be P^2H , which seems improbable. Produced by the action of hot hydrochloric acid on phosphide of calcium. A solid, of two kinds, green and yellow. Take fire at 300°F .

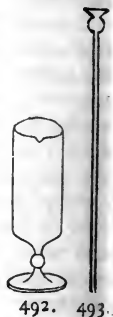

The young chemist is again reminded that all experiments made with phosphorus, with phosphuretted hydrogen, or with other preparation of phosphorus, must be made with great care, to prevent accidents from fire or from explosions, or from the noisome stink and unwholesome atmosphere which such experiments produce in the apartment in which they are performed, when there is no thorough ventilation.

ARSENIC.

10. THE ARSANOUS RADICAL = As. *Equivalent, 75.*

11. THE ARSANIC RADICAL = Asc. *Equivalent, 25.*

The specific gravity of Arsenic in vapour is 150. Assuming this to represent Asc, its atomic measure when isolated is $\frac{1}{3}$ volume. In salts it is the same. It reduces the atomic measure of every radical with which it combines to form a gaseous salt from 1 volume to $\frac{1}{2}$ volume. See pages 138 and 142.

Metallic arsenic forms rinds and crystalline masses of a steel-grey colour, with a brilliant metallic lustre, but which lose their lustre and become black on exposure to the air. It is brittle, and easy to powder. Its sp. gr. is 5.7 to 5.95. When heated, it readily volatilises without undergoing fusion. The vapour possesses a peculiar odour, resembling that of garlic. It deposits on cold bodies as brilliant crystals. When heated in the air it produces a white smoke, which is arsenious acid. When more powerfully heated, or when heated in oxygen gas, it burns with a pale-blue flame, producing arsenious acid.

It dissolves in hot nitric acid, producing arsenious acid. It dissolves in aqua regia, producing arsenic acid. It is insoluble in hydrochloric acid. Arsenic and all its compounds are poisonous. Arseniuretted hydrogen gas is peculiarly dangerous. Its smell is deadly.

In consequence of the virulent poisonous properties of arsenic and its compounds, they should be handled with the utmost precaution. They are never to be tasted, and are not to be smelt without great care. When they are reduced and volatilised before the blowpipe, the odour of garlic which they produce betrays them. An extremely small quantity of any arsenical compound will produce this odour. In examining metallic minerals before the blowpipe, this odour is often produced. The student should know it, and avoid smelling or inhaling it more than is absolutely necessary.

ARSENIOUS ACID. *White Arsenic.*—A heavy white powder, which sublimation converts into a white glassy mass. Very volatile, the vapour not odorous; easily reducible by ignition with charcoal, or cyanide of potassium, the vapour giving the garlic odour peculiar to metallic arsenic; sparingly soluble in water, easily soluble in hot hydrochloric acid, and the solution deposits anhydrous octahedral crystals of arsenious acid when it cools. A violent poison.

The two kinds of arsenious acid differ considerably in their form, transparency, solubility, and other properties, but they are easily convertible, the one into the other, and they have the same ultimate composition, namely, 50 parts by weight of arsenic to 16 parts of oxygen,

It is, nevertheless, possible that they may differ in their proximate constitution as follows:—

As, AsO³ = Arsanous arsanousite. Equivalent, 198.
Asc, AscO = Arsanic arsanicate. Equivalent, 66.

It is, however, at present impossible to say which of these formulæ should be given to the crystallised variety, and which to the amorphous glassy variety. The specific gravity of its gas is 198, which is equal to the atomic weight of As, AsO³, making the atomic measure 1 volume. But if the atomic weight is 66 = Asc, AscO, then the atomic measure is $\frac{2}{3}$ volume. In either case the oxygen measures nothing.

Arsenious acid is prepared, on the large scale, by the roasting of ore of iron, cobalt, nickel, and other metals which contain it as a constituent. It is purified by re-sublimation, which produces the glassy form. That variety is reduced to the opaque variety by exposure to air, by long boiling in water, or by the mechanical agitation caused by grinding it to powder.

ARSENIC ACID. *Formula, As, AsO³; Equivalent, 230.*—Colourless fusible, glassy mass. Deliquescent, forming an acid solution in water. *Preparation.*—4 parts of arsenious acid, 1 part of hydrochloric acid, sp. gr. 1.2, and 12 parts of nitric acid, sp. gr. 1.25, are to be boiled together to dryness, and the residue is to be very slightly ignited.

ARSENITES.—Soluble alkaline arsenites are formed as follows:—Boil a solution of caustic potash in a porcelain capsule or a glass flask. Add to the boiling solution as much powdered white arsenic as it will dissolve. As long as the solution of potash is not saturated with the acid it gives a brown precipitate with a solution of sulphate of copper. When it is saturated it gives a splendid green precipitate. The saturated solution then contains arsenite of potash, by means of which any insoluble arsenite can be produced by double decomposition. The following are examples:—

Precipitates produced by Solutions of Arsenites.

WHITE	Lime-water in excess. Chloride of calcium with excess of ammonia.
Arsenite of lime.	
ORANGE YELLOW	Sulphuretted hydrogen with excess of hydrochloric acid.
Sulphide of arsenic.	
YELLOW	Nitrate of silver with excess of ammonia.
Arsenite of silver.	
GRASS-GREEN	Sulphate of copper with excess of ammonia.
Arsenite of copper.	

Detection of Arsenites. See page 93.

Constitution of the Arsenites.—Supposing the acid to be the arsenous anhydride As, AsO³, the corresponding normal salts will be MAsC because in the above experiment—

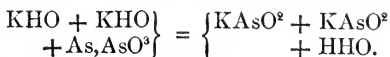

Other salts occur producing the following series:—

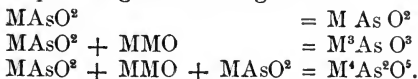

And other still more complex salts also occur, some of which agree better with the series MAscO than with the above series. The arsenite of potash of the arsenic series would be produced thus:—

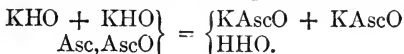

And all the salts of that series can be formulated as compounds of MAscO with HAscO and AscAscO, in various proportions, producing salts similar in form to the borates and silicates. It seems to be not improbable that there exist two distinct classes of arsenites, as well as two kinds of arsenious acid, namely—

The Arsanous series = MAsO.

The Arsenic series = MAscO.

ARSENIATES.—There are three kinds of arseniates constituted in accordance with the following formulæ:—

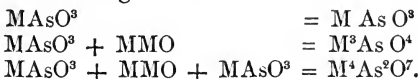

The arseniates are much more stable salts than the arsenites.

The soluble salts are produced by saturating a solution of arsenic acid with carbonated alkali. The insoluble salts by precipitation from an alkaline arseniate. All the alkaline salts are soluble in water. The others are insoluble in water, but soluble in nitric and hydrochloric acid. The tribasic salts are of these kinds—



These salts are rendered anhydrous by heat; so that, for example, $\text{MH}^2, \text{AsO}^4$ becomes $\text{M}, \text{AsO}^3 + \text{HHO}$; but the monobasic salt recovers its water if redissolved. The monobasic and bibasic salts are not obtainable in crystals free from water.

The Solutions of Arseniates give the following Precipitates:—

ROSE-RED . . .	Cobalt salts.		WHITE . . .	{	The earths.
BROWN-RED . . .	Silver.				Manganese.
GREEN	Nickel.				Iron.
GREENISH-BLUE	Copper.				Lead.
YELLOW {	Mercuric salts.				Zinc.
	Sulphuretted hydrogen.	Tin.			
			2 U 2		

Detection of Arseniates. See page 94.

SULPHIDES OF ARSENIC.—(a) *Red Sulphide*, or *Realgar* = AsS^2 . Prepared by melting sulphur with half its weight of white arsenic. A yellowish-red, transparent, glassy mass, with glancing shelly fracture. Very fusible and volatile.—(b) *Yellow Sulphide of Arsenic*, or *Orpiment* = AsS . Prepared by precipitating arsenic from an acidulated solution of arsenious acid, by means of a current of sulphuretted hydrogen gas. A yellow powder, fusible, and volatile.—(c) *Pentasulphide of Arsenic* = $\text{AsS}^4 + \text{S}$. Prepared by passing a current of sulphuretted hydrogen gas into an acidified solution of arsenic acid. A pale-yellow precipitate, very slowly produced. The precipitation of arsenic by sulphuretted hydrogen is most effectual at a boiling heat.

Constitution of Double Salts containing Sulphides of Arsenic.—The sulphides of arsenic combine with metallic sulphides, and produce a great variety of double sulphur salts, not only in the laboratory of the chemist, but in that of nature; for many metallic ores belong to this class of compounds. I shall not enter here into details on one of the most complex parts of chemical mineralogy, but simply offer a suggestion as to the constitution of these salts; which suggestion is founded on the idea that I have thrown out at page 623 respecting the probable existence of compound sulphur radicals of two particular sorts, corresponding in constitution to amidogen and ammonium. To illustrate these views I will refer to the compound sulphides of arsenic and potassium:—

1. *Orpiment* is AsS , and its compounds are—

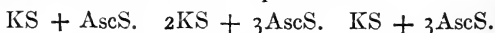

2. *Realgar* is AsS^2 . It forms these compounds:—

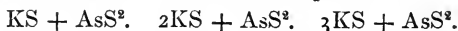

3. *Pentasulphide* I regard as $\text{AsS}^4 + \text{S}$. Its compounds are as follow:—

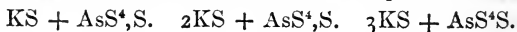

ARSENIURETTED HYDROGEN. — *Formula*, HAsc ; *Equivalent*, 26 *Specific gravity of gas*, 39; *Atomic measure*, $\frac{4}{3}$ volume. A colourless gas, possessing the odour of garlic. Exceedingly poisonous. It is even dangerous to smell it. It is produced by putting zinc and hydrochloric acid into a solution containing arsenious acid, or any arsenite. The nascent hydrogen combines with the arsenic, and produces gaseous arseniuretted hydrogen. This gas is decomposed when burnt at a jet or when passed through a red-hot tube, in both cases depositing metallic arsenic.

If the formula of this gas is tripled, and we write it AsH_3 , like an ammonia, then its atomic measure becomes 2 volumes, also like that of an ammonia.

DETECTION OF ARSENIC.

1. *Detection of Arsenic in Sulphuric Acid.*—When oil of vitriol is made from sulphur, distilled from iron pyrites, it frequently contains arsenic. That result is to be lamented, because it is impossible to say where the sulphuric acid may spread the poison. It goes, for example, into superphosphate of lime; thence into turnips grown with that manure; and thence, as food, into animals or human beings. From sulphuric acid it goes into hydrochloric acid, and possibly into all acids and salts in the manufacture of which sulphuric acid is an agent. It is consequently important to check this evil by frequent examination of the acid delivered in commerce, in order that the arsenical acid may be thrown back upon any manufacturer who is too careless of the public safety.

Process A). Boil the oil of vitriol with a little sugar. Dilute it with water. Pass into it a current of sulphuretted hydrogen gas, which, if arsenic is present, gives a yellow precipitate. If the quantity of arsenic is small, it is best detected in boiling acid.

Process B). Dilute the oil of vitriol with water, and saturate it with carbonate of potash. Sulphate of potash will precipitate. Separate it by filtration, and wash it with a little water. Concentrate the filtered solution by evaporation: acidify it by pure hydrochloric acid, boil it, and test with sulphuretted hydrogen gas.

2. *Detection of Arsenic in Hydrochloric Acid.*—Dilute the strong hydrochloric acid with twice its bulk of water. Boil the diluted acid, and while it boils pass sulphuretted hydrogen gas into it. If arsenic is present, a yellow precipitate is produced. But the yellow precipitate should be examined, to see that it is not sulphur only. See experiment 8.

3. *Detection of Arsenic in Phosphoric Acid (in which it will exist as Arsenic Acid).*—Boil the acid liquid with a little hyposulphite of soda, until it ceases to smell of sulphurous acid. Then test with the aqueous solution of sulphide of hydrogen.

4. *Precautions.*—When small quantities of arsenic are to be detected, the HS gas should be passed into the solution continuously for at least six hours. The solution should be acid, never neutral or alkaline. If aqueous sulphide of hydrogen is mixed with the liquor to be tested, the mixture should be in a stoppered bottle, and set aside for some time in a warm place. The yellow precipitate should be carefully collected on a filter, and washed. The funnel is then to be put over a watch glass, and the precipitate to be dissolved by a few drops of ammonia. The watch glass is to be heated over a water bath, till the sulphide of arsenic is again left dry. It is then to be reduced to metallic arsenic by the processes described in Nos. 8 and 9 below.

5. *Detection of Arsenious Acid in Neutral Solutions.—a*). By am-

monia-nitrate of silver. This test gives a *yellow* precipitate, which is soluble both in nitric acid and ammonia. *b*). By ammonia-sulphate of copper. This test gives a *green* precipitate, which is soluble in ammonia and in acids. To prepare the test *a*), add a slight excess of ammonia to a solution of nitrate of silver, but not enough to dissolve all the precipitated oxide of silver. The clear liquor is to be decanted for use. To prepare the test *b*), add ammonia to a solution of sulphate of copper, with similar precautions.

6. *Reduction of Arsenious Acid.*—Put a minute quantity of arsenious acid at the point, *a*, of a test tube; and at *b c*, put a long narrow



494.

splinter of charcoal, previously dried by ignition in a closed tube. Heat the tube with a spirit-lamp from *b* to *c*, and when the charcoal is red hot, bring the point, *a*, into the flame. The vaporised arsenious acid is reduced by the charcoal, and metallic arsenic is deposited at *d*.

7. Arsenious acid, or any compound containing arsenic, mixed with dry carbonate of soda, and heated on a reducing pastile in the inner blowpipe flame, produces the garlic odour of arsenic. This test is very delicate.

8. *Extraction of Metallic Arsenic from the Sulphide.*—The sulphide is put at the point, *b*, of a subliming tube, and above it a quantity of dry and recently-charred tartrate of lime. A strong spirit-lamp heat is



495.

applied to the latter, and when it is red hot the point of the tube is brought into the flame, upon which the sulphide is decomposed, and metallic arsenic is deposited at *a*.

9. One part of the sulphide is mixed with three parts of cyanide of potassium and nine parts of dry carbonate of soda. The mixture is put into a narrow tube of hard glass, which is placed horizontally, and connected with a gas bottle, from which a slow current of dry carbonic acid gas is passed through the tube. Heat is then applied to the tube below the mixture, whereupon metallic arsenic sublimates and condenses upon the cold part of the tube.

10. *Reduction of Arsenite and Arseniate of Lime.*—Mix the dried arsenite or arseniate with three times its bulk of recently-charred oxalate

of lime, and a little boracic acid. Put the mixture into a small bulb *a*, without soiling the tube, and heat the mixture gradually to ignition.

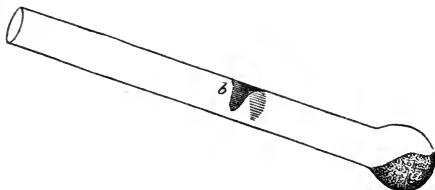

496.

The metallic arsenic is deposited at *b*. The tube must be held aslant, that the water disengaged from the arsenite may not run down to the red-hot bulb and break it. The subliming tubes used in the analysis of arsenical substances must be made of infusible Bohemian glass, free

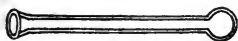

497.

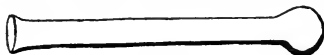

498.

from lead. Most of the reducing experiments can be made satisfactorily in tubes no larger than the above figures, 497, 498. The following is Berzelius's form of subliming tube.

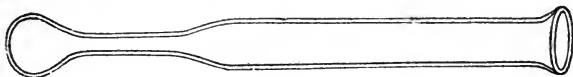

499.

SEARCH FOR ARSENIC IN MIXTURES OF VEGETABLE AND ANIMAL SUBSTANCES.

Boil the liquor, filter it, and use separate portions for each of the following experiments.

11. *Reinsch's Test*.—Make the suspected arsenical solution acid by the addition of hydrochloric acid, and boil it with some slips of bright, clean, pure copper in foil. If any arsenic is present, it will be reduced upon the copper foil. Take out the copper, wash it, dry it, fold it up, put it into a long narrow tube of hard Bohemian glass of the diameter of fig. 496, and open at both ends; hold the tube in an inclined position over a spirit-lamp, and heat the copper to redness. The arsenic on the copper will be oxidised by the air which passes up the heated inclined tube, and the arsenious acid produced by the oxidation will be deposited on the cold part of the tube in transparent octahedral crystals.

12. *Marsh's Test*.—The apparatus consists of a bent glass tube, either with or without bulbs. It is supported in a vertical position, and provided with a stopcock and fine brass jet, as represented by fig. 500. A bit of pure zinc is put into the short branch, and below it a piece of glass rod, to prevent the zinc from slipping into the bent part of the tube. Pure hydrochloric acid, not stronger than 10° , is put into the apparatus till it rises half way up the short branch. Hydrogen gas is immediately produced, which fills the short branch, and can be made to sweep the atmospheric air out of the apparatus. If a solution of arsenic is then poured into the long branch, the gas next produced will be arseniuretted hydrogen.—*a*). If the jet is partially opened, the gas inflamed, and a bit of white porcelain held in the flame, a black mirror of metallic arsenic is deposited on the porcelain.—*b*). If the gas is burnt in the manner described at fig. 209, page 213, an aqueous solution of arsenious acid will be collected in the receiver at *e*, and solid arsenious acid will be deposited in the bent tube, *c*.

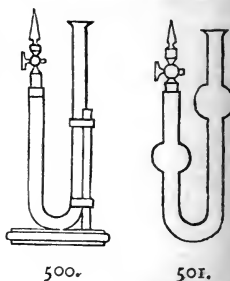

13. *Clark's Test*.—Liquors containing organic matters may be subjected to Marsh's Test, and the presence of such matters does not hinder the separation of the arsenic; but they occasion an excessive frothing which often spoils the experiment. It is prudent, therefore, to separate arsenic from organic matters before subjecting it to special tests.

The following apparatus for such a separation of arsenic from organic matters has been recommended by Professor Clark. A is a sulphuretted hydrogen bottle, page 615; *b* a block of wood by which the cork, the funnel, and the bent tube, *a*, are fixed together. The V-tube

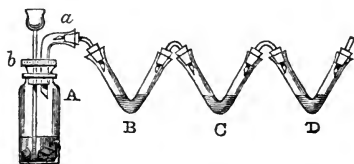

502.

B, contains a solution of caustic potash. C a solution of acetate of lead, and D a solution of nitrate of silver. Pure hydrogen gas is prepared by this apparatus, and when it is found that the hydrogen gas passes through B, C, and D without action, the arsenical liquor is poured into the gas bottle by the funnel. The great capacity of the bottle permits considerable frothing without damage. The arseniuretted hydrogen passes through the V-tubes. In B it deposits sulphuretted hydrogen and some other impurities. In C it produces no action, if the washing in A is sufficient. In D it throws down metallic silver, and the arsenic is retained in solution. When the current c

gas ceases, the liquor in D is mixed with hydrochloric acid to throw down the excess of silver, and the liquor is filtered and evaporated to dryness. This produces pure arsenic acid, which can be converted into an arseniate, or otherwise subjected to its appropriate tests.

14. Remove the V-tubes from the apparatus last described, and attach to the bent tube, *a*, a long tube of hard Bohemian glass, of one-fifth inch diameter; make the middle of this tube red hot by a spirit-lamp, and pass the arseniuretted hydrogen through it. The gas will be decomposed by the red-hot glass, and metallic arsenic will be deposited a little beyond the flame.

15. *Regnault's Modification of Marsh's Test.*—A, fig. 503, is the flask in which the gas is prepared for examination. It ought to be rather large to permit of the expansion of the materials. The tube *m, n*, is for the introduction of the liquor that is to be tested. The bulb *b*, in the tube *a b*, is to receive the greater part of the liquor that is carried up by the gas. The tube *c, d*, filled with asbestos, is also intended to arrest any liquor that may be carried over. Finally, the tube *d, f, g*, twelve or sixteen inches long, formed of very hard glass,

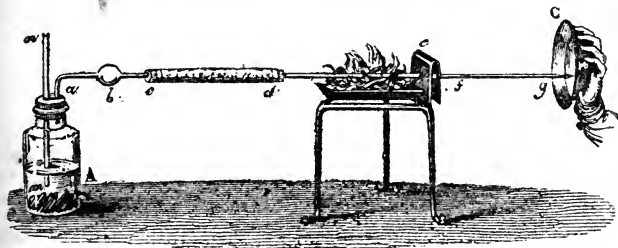

503.

and drawn out to a jet at the end, *g*, completes the apparatus. Pure hydrogen gas is circulated through this apparatus from the bottle A, to expel atmospheric air. A portion of the horizontal tube, about four inches in length, is now heated by a charcoal fire, or by any corresponding means. That part of the tube marked *f, g* is to be preserved from the heat by the interposition of the screen *e*. The hydrogen gas is then lighted at *g*. The action of the pure hydrogen gas is thus continued for some time to ascertain that no deposit is formed in the tube between *f* and *g*. At the same time, a bit of white porcelain, such as a broken capsule, or the cover of a crucible, is held against the flame at *g*, to ascertain if any metallic arsenic is deposited there. The results being negative, the suspected liquor is poured into the bottle by the funnel, and as much acid is added to the zinc as sustains a constant current of gas. The flame at *g* ought never to be above a quarter of an inch long, or the operation is going on too fast. If arsenic is present,

most of it is deposited at *f*, near to the screen, but enough escapes in the current to give spots of arsenic on porcelain plates *c*, held at *g*. These spots serve afterwards to try the action of different reagents.

16. *Caution.*—Antimony, as well as arsenic, gives metallic spots with Marsh's test. The spots of arsenic dissolve in a dilute solution of chloride of lime; those of antimony do not. If sulphide of ammonium, in which a little sulphur is dissolved, is added to an antimony spot, the metal dissolves, and the solution on evaporation leaves an orange-coloured residue. The arsenical spots are scarcely at all acted on by that test.

17. *Parallel Trials.*—Every experiment made with a liquor suspected to contain arsenic should be checked by a comparative experiment made without that liquor, but with the same apparatus; the same kind of zinc, water, and acid, and in precisely the same routine, in order to prove that the results supposed to be such as to indicate the presence of arsenic in the suspected liquor, are not results proper to attribute to defects in the operation, to impurities in the chemical reagents, or to arsenical residues in the apparatus employed for the analysis.

ANTIMONY.

12. THE STIBOUS RADICAL = Sb. *Equivalent, 120.*

13. THE STIBIC RADICAL = Sbc. *Equivalent, 40.*

The specific gravity of antimony as gas is unknown. In salts, it has an atomic measure of $\frac{1}{2}$ volume, and it condenses all radicals with which it combines from 1 volume to $\frac{1}{2}$ volume. See pages 138 and 142.

ANTIMONY is a metal of silver-white colour, with a strong metallic lustre and a leafy structure. Its sp. gr. is 6.7. It is brittle and easy to powder. When heated to 840° F., it fuses. If excluded from air during the operation, it volatilises only in a very slight degree; if ignited in the open air, it remains red-hot for some time after removal from the fire, and produces a thick, white smoke of oxide of antimony, which gradually forms a mass of shining crystals on the face of the residual antimony. If a morsel of antimony is ignited on charcoal before the blowpipe, the fused metallic bead exhibits a net-work consisting of crystallised oxide of antimony. If the heat is sustained, the antimony volatilises completely in the state of oxide. If the hot bead of antimony is thrown from the charcoal to the floor, it parts suddenly into numerous smoking fragments. If a quantity of antimony is melted in a crucible, and poured upon the ground or upon a stool, from a height of three or four feet, it forms a multitude of smoking globules, which rush upwards like an explosion from a volcano.

Hot nitric acid converts antimony into an insoluble oxide of antimony. Hydrochloric acid does not dissolve antimony. Aqua regia dissolves

antimony completely; the resulting solution gives a white precipitate upon being mingled with water. Chlorine gas passed over warm antimony produces liquid chloride of antimony. A variety of useful alloys have antimony for one of their constituents; the metal for printers' types, that on which music is engraved, and pewter, belong to this class. Antimonial preparations serve also as paints and as medicines.

Antimony is procured from the mineral called sulphide of antimony. The crude antimony of commerce is merely that mineral separated by fusion from the greater part of its earthy impurities.

A. ANTIMONIOUS SALTS.

1. Antimonious anhydride, Sb, SbO^3 , commonly called antimonic acid.
2. Hydrated antimonic acid = HSbO^3 .
3. Neutral antimoniate of potash = KSbO^3 .

Multiple Salts of Antimonic Acid. Examples:—



7. Pentasulphide of antimony = $\text{SbS}^4 + \text{S}$.
8. Pentachloride of antimony = $\text{SbCl}^4 + \text{Cl}$.
9. Schlippe's salt = $3\text{NaS} + \text{SbS}^4, \text{S} + \text{Aq}^9$.

All the above salts contain the stibous or antimonious radical, $\text{Sb} = .120$, though their usual names imply the contrary.

B. ANTIMONIC SALTS.

10. Teroxide of antimony = Sbc, SbcO .
11. Antimoniuretted hydrogen = HSbc .
12. Tersulphide of antimony = SbcS . (Antimony ore.)
13. Terchloride of antimony = SbcCl .
14. Powder of algaroth = SbcClO .
15. Tartrate of antimony = $\text{Sbc}^3, \text{C}^2\text{H}^2\text{O}^4$.
16. Tartar emetic = $\text{K, C}^2\text{H}^2\text{O}^3 + \text{Sbc}^3, \text{C}^2\text{H}^2\text{O}^4$.
17. Antimonic acid = $\text{Sbc}^3, \text{SbO}^4$.

In these salts, Sbc signifies the stibic or antimonic radical, the equivalent of which is = 40 .

Constitution of the Salts of Antimony.—These salts present no form of combination which is peculiar to antimony or different from those which have been frequently investigated and explained in the preceding pages. No. 1 is evidently the anhydride of the hydrated acid No. 2, of which No. 3 is the normal or monobasic salt. But antimony is endowed with the power of making a multitude of complex salts. Thus the antimoniates produce tribasic salts by combining with salts on the model of water. $\text{HSbO}^3 + \text{HHO}$ produces H^3, SbO^4 , and this

combines with the normal salt to produce the compound salts No. 4 and No. 6, equal to H^4, Sb^2O^7 . In No. 5, we have a salt similar to the dried bisulphates (see page 596), in which half the acid radicals are neutralised with basic radicals, and half remain in the condition of anhydride. No. 7 is a salt of one of these ammonium-like radicals which I have referred to at page 623, and No. 9 is a quadruple salt, containing the salt No. 7. No. 8 is a chloride, in which we see another variety of these compound ammonium-like radicals.

The salts Nos. 10 to 17 are so fully explained by their formulæ, that it seems needless to say anything about them. All these formulæ are, however, so different from those in common use, that I regret that the narrowness of my space does not allow me to enter upon a justification of the proposed alterations. I must limit this article to a few notes descriptive of the most important of the above salts.

Teroxide of Antimony. $Sbc, SbcO$. Also called protoxide of antimony.—Prepared by igniting antimony in the open air, or by boiling it in a mixture of nitric acid and diluted sulphuric acid. It is white, turns yellow when heated, fuses, and, on cooling, forms a grayish crystalline mass. It sublimes in crystals when heated in close vessels is easily reduced when ignited with charcoal.

Detection of Oxide of Antimony in Salts.—Page 89.

NATIVE SULPHIDE OF ANTIMONY. $SbcS$.—Obtained as a mineral Lead-gray, compact, fibrous, sometimes found in prisms. Fuses in close vessels without change. The antimony of commerce is extracted from this ore. Dissolves in boiling hydrochloric acid, under disengagement of sulphuretted hydrogen gas. It is therefore sometimes employed in the preparation of sulphuretted hydrogen gas. An equivalent sulphide of antimony can be prepared by melting antimony with sulphur. The sulphide of antimony obtained by precipitation has an orange colour.

CHLORIDE OF ANTIMONY. *Butter of Antimony* = $SbcCl$.—A soft solid easily liquified by heat, and giving crystals on cooling. Produced by throwing powdered antimony into a jar of chlorine gas, an operation attended by combustion. Also produced by distilling a mixture of eight parts of corrosive sublimate with three parts of metallic antimony both in fine powder. The butter of antimony distils over. It is used for bronzing gun-barrels.

TARTAR EMETIC. $K, C^2H^2O^3 + Sbc^3, C^2H^2O^4$.—A double tartrate of potash and antimony; an important salt in medicine. It is prepared thus:—three parts of oxide of antimony and four parts of cream of tartar are made into a thin paste with water, digested for some hours and then boiled with six or eight times their weight of water. The solution is filtered while hot, and the salts crystallise as it cools. It forms very fine crystals, which are soluble in fifteen parts of cold water. Their solution is acid. It is a powerful emetic and cathartic poison.

14. CHLORINE.

Symbol, Cl; *Equivalent*, 35.5; *Specific gravity of gas*, 35.5; *Atomic measure when isolated*, 1 volume; *Atomic measure when acting as a radical in salts*, 1 volume; *Condensing action on the atomic measure of other radicals*, 0.

Occurrence.—See page 11.

Properties.—Chlorine forms a transparent gas of a yellowish-green colour. Its sp. gr. is 35.5, so that it is nearly three times as heavy as atmospheric air. It is reducible by a pressure of about four atmospheres at 60° F. to the state of a dark-yellow oily liquid, of sp. gr. 1.33, against water at 1.00. Chlorine gas has a suffocating odour, and if respired pure, it produces immediate death. It is not combustible, but it is capable of supporting the combustion of a variety of substances; many even inflame in it spontaneously. With a small quantity of water, it forms yellow crystals; with a large quantity, it produces a pale-yellow solution commonly called *liquid chlorine*: this solution has a choking odour like the gas, and possesses the property of bleaching all vegetable colours, which property is also possessed by the gas when mixed with vapour of water, but not otherwise. The solution does not absorb a very large quantity of chlorine, nor does it remain long without undergoing decomposition. Chlorine destroys the noxious fetid effluvia that are produced by the corruption of vegetable and animal bodies. It also destroys the miasma that occasion particular diseases. Hence its use in checking the spread of fever, cholera, &c.

As chlorine forms three-fifths of the weight of rock salt and sea salt, it exists in nature in enormous quantities.

Chlorine combines with oxygen in different proportions. With oxygen and hydrogen, it forms chloric acid; with oxygen and metals, it forms the salts termed chlorates; with hydrogen, it forms hydrochloric acid; with the metals, it forms the important compounds or salts termed chlorides, an example of which is afforded by common salt, a compound of chlorine and sodium; with sulphur, nitrogen, carbon, and other elements, it produces a great variety of chlorides and more complex compounds.

Hydrochloric acid is a true chloride, differing from the chlorides of metals only in having an equivalent of hydrogen instead of an equivalent of a metal. Muriate of ammonia is also a true chloride, containing hydrogen and nitrogen jointly in place of a metal. Chemists also call this salt chloride of ammonium, and suppose the hydrogen and nitrogen

ganes. No more acid need be added than is demanded for the desired quantity of gas. When the operation is ended, the stopper and tubes are taken out, and, after being washed, are hung up out of the way. The flask is inverted, and the acid run out, but the manganese is suffered to remain, ready for the next operation, being, however, each time filled up to the stopper with fresh lumps of manganese, of the size of peas. In this manner the greatest economy of materials is insured, and the apparatus is always ready to supply the gas when required.

As chlorine gas readily corrodes corks, it is preferable to fit up bottles for preparing it with the caoutchouc caps that have been described at page 179, for these are not destroyed by chlorine. When corks are used, they should never be left tightly fitted into gas-bottles, because they lose their elasticity.

3. The following apparatus for the preparation of chlorine is copied from Professor Mitscherlich's *Lehrbuch der Chemie*. It requires no special description. The trough is of glass, bound with brass.

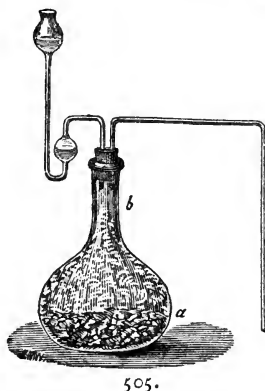

505.

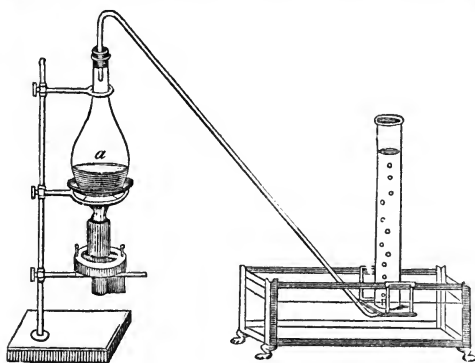

506.

Chlorine gas is absorbable by about half its volume of *cold* water under strong agitation; but if collected quietly over cold water, not much of it is absorbed. If the water is made warm, other and greater inconveniences arise. The gas, therefore, must be received in bottles filled with, and inverted in, cold water. They must have wide necks,

and be provided with accurately-ground and well-greased stoppers, which must be introduced under water while the bottles remain full of gas, and no water must be left in the bottle with the gas. See fig.



507.

507. If the gas is collected warm, over warm water, the stoppers of these bottles often become fixed beyond removal. A solution of common salt absorbs chlorine gas less freely than pure water does. Chlorine gas cannot be collected over mercury, because it combines with that metal at the ordinary temperature of the air; but as it is more than twice as heavy as common air, it may be collected in dry vessels by the method of DISPLACEMENT, described at page 593. The peculiar colour of this gas enables one to see when the bottles are full.

In experiments with chlorine, great care should be taken that it does not escape in any considerable quantity into the apartment, as its action on the lungs is extremely injurious. Hence the first portions of gas which come over from the gas-bottle, and which are contaminated with the atmospheric air of the apparatus (see page 180), are not to be suffered to escape into the apartment, but are to be collected in a large jar, and that jar is to be removed in a water-tray (see fig. 119, page 168) into the open air, where the gas is to be washed out of the jar with water, the operator taking care not to inhale the chlorine. In bottling chlorine, no water must be left in the bottle, because the action of light in the presence of water converts chlorine into hydrochloric acid gas, $\text{Cl} + \text{Cl} + \text{HHO} = \text{HCl} + \text{HCl} + \text{O}$, and as the water condenses that acid gas completely, a vacuum is produced in the bottle, and the stopper becomes fixed immovably by the pressure of the atmosphere.

4. *Preparation of Dry Chlorine Gas.*—As chlorine gas is saturated

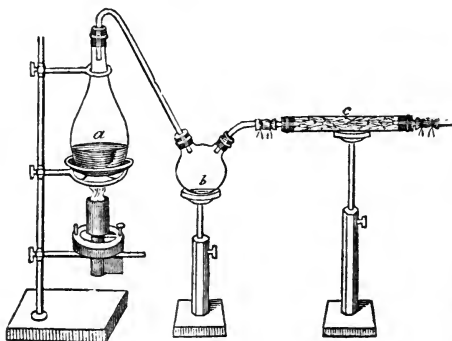

508.

with moisture, when it issues from the gas-bottle, it may, when required dry, be prepared with the apparatus shown by fig. 508:—The gas is produced in the flask *a*, it deposits a portion of its water in the receiver *b*, and is deprived of the remainder by lumps of fused chloride of calcium contained in the tube *c*. Instead of the straight tube *c*, such tubes as I have described at page 198 may be used for this purpose.

5. *Liquid Chlorine, or Solution of Chlorine.*—Pass a slow current of chlorine gas into cold water till it ceases to be absorbed. One measure of water absorbs about two measures of the gas at mean temperature. The water must be previously boiled to free it from air. The best process for effecting the saturation of water with chlorine, or indeed with any gas, is the *shaking* process, recommended by Dr. Mohr, and which I have described under the head of “solution of sulphide of hydrogen,” process 2, page 619. The gas is passed into bottles partly filled with water, and these bottles are alternately well shaken until the water is fully saturated. While the bottles are receiving the gas, they may be placed in cold water, to keep down the temperature. The saturated solution of chlorine should be kept in small opaque bottles, quite filled, and closely stopped. Stoneware or black glass bottles may be used. The solution decomposes when exposed to light. In bright sunshine it disengages oxygen gas, and is converted into hydrochloric acid:—



6. *Preparation of Chlorine Gas, from Peroxide of Manganese, Chloride of Sodium, and Oil of Vitriol.*—If peroxide of manganese is heated with a mixture of common salt and oil of vitriol diluted with a little water, the manganese being in excess, and the other materials in proportions equivalent to each other, chlorine is disengaged. This process is not so convenient, in the small way, as that performed with MnO and HCl ; but I notice it in order to explain the theory of the reactions, which, on the Radical Theory, is very simple:—

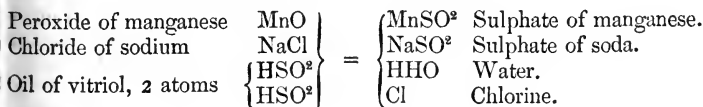

7. *Hydrate of Chlorine* = $\text{Cl} + 5\text{HHO}$.—The saturated solution of chlorine, cooled below 32°F ., deposits this compound in crystals. If a bent glass tube, fig. 509, is nearly filled with these crystals, and then closed hermetically, and heated to 100°F ., the crystals melt and form two liquids; the under one is an-



509.

hydrous liquid chlorine, the upper one is aqueous solution of chlorine, and above all is highly compressed chlorine gas. If the tube is then cooled below 32° F., the hydrate of chlorine is again formed.

EXPERIMENTS WITH CHLORINE GAS.

Particular care must be taken not to breathe the chlorine gas, nor the vapours produced in the experiments, such as chloride of arsenic, &c. It would be highly dangerous to make these experiments in a small unventilated apartment. The gas is destructive to valuable furniture, coloured hangings, polished metals, &c.

When the air of a room is tainted with chlorine, it can be a little improved by waving in it a cloth sprinkled with alcohol and ammonia.

All the experiments in which metals are to be combined with chlorine by spontaneous combustion, succeed best when the gas is dried by chloride of calcium, and collected by displacement in glass bottles provided with stoppers. Bottles of the capacity of one or two quarts are suitable.

1. Plunge a lighted taper into a jar of chlorine gas; it begins to burn with a dull red flame, and a copious emission of dense fumes; but the flame is soon extinguished. See fig. 140, page 181.

2. A slip of paper moistened with very concentrated liquid ammonia, inflames spontaneously in chlorine gas.

3. If a folded slip of filtering paper, moistened with spirits of turpentine, be immersed in a jar of chlorine gas, it inflames immediately, with evolution of much smoke.

4. Introduce a grain of phosphorus, well dried on bibulous paper, divided into small pieces, and suspended in the iron spoon, fig. 142, page 182, into a bottle of chlorine gas. It immediately inflames spontaneously, and burns with a pale-green flame, producing chloride of phosphorus.

5. Into a small quantity of chlorine water contained in a porcelain capsule, put a piece of sodium. It burns, and dissolves as it does upon water; and if the metal is enough in quantity to act upon all the chlorine, the liquid produced will be a solution of chloride of sodium or common salt.

6. Camphor, caoutchouc, ether, &c., inflamed and put into chlorine gas, continue to burn therein.

7. A jet of chlorine gas burns in an atmosphere of hydrogen gas, or coal gas.

8. A bit of potassium passed up into chlorine gas contained in a jar over water, burns with flame.

9. Melt a little sulphur in the deflagrating spoon, and put it while liquid into a bottle of chlorine gas. It will immediately take fire, and burn rapidly.

10. Heat a little mercury in a deflagrating spoon, and introduce it while hot into a bottle of chlorine gas. It immediately takes fire, and burns with a reddish flame, producing chloride of mercury.

11. If mercury is boiled in a small retort, the neck of which is passed into a vessel containing chlorine gas, the vapour of mercury, issuing from the retort, will burn in the atmosphere of chlorine. The vapour may be kindled by applying a bit of phosphorus on a wire.

12. Throw powdered antimony into a long tube filled with chlorine gas, and held mouth upwards. It will produce a shower of burning stars of a yellow light.

13. Powdered metallic arsenic, employed in like manner, exhibits white stars.

14. Copper leaf introduced into chlorine gas inflames immediately. Dutch gold burns in the same manner.

15. The preceding experiment may be performed in a more striking manner by the aid of the apparatus represented by fig. 198, page 204. The globe *b* is to be loosely filled with thin copper foil. It is then to be exhausted of air and screwed to the jar *a*. The latter is filled with chlorine, and placed on the shelf of the water trough. Whenever the stopcocks are opened, the chlorine rushes into the globe *b*, and the copper takes fire.

16. A leaf of pure gold put into chlorine water dissolves, although it will not dissolve in hydrochloric acid.

17. Many different metals, in the state of spiral-formed wires, page 187, can be burnt in dry chlorine gas, if the bottom of the spiral is loosely enveloped in a leaf of Dutch gold, for the purpose of commencing the combustion.

18. Partly fill a jar with sulphuretted hydrogen gas over water; pass a little chlorine gas into it. Sulphur will be deposited, and the water will rise in the jar, muriatic acid being formed. $HS + Cl = HCl + S$.

19. If equal volumes of chlorine gas and hydrogen gas are mixed and kindled by flame, an explosion is produced. The product is muriatic acid. See page 206.

20. Equal volumes of chlorine gas and hydrogen gas mixed in a clear colourless bottle, and exposed to bright sunshine, combine, with violent explosion, producing muriatic acid. The action is so rapid, that if the bottle is suddenly thrown up into the air, the explosion occurs before the bottle falls to the ground. Consequently, it is necessary to be careful how you mix these gases in a light laboratory. All danger is avoided in the following experiment:—

21. Into a japanned cylinder of plate iron, of the capacity of twelve cubic inches, put equal measures of hydrogen gas and chlorine gas. When the cylinder is full of gas, set it, mouth upwards, upon a table, keeping the mouth closed by the palm of the left hand. Take in the right hand a bent copper wire, having the lower end loosely covered

with a leaf of Dutch gold. Remove your left hand, and dip the Dutch gold into the mixed gases. A loud, but not dangerous, explosion takes place immediately.

22. Mix one volume of olefiant gas with two volumes of chlorine gas, and inflame the mixture. It burns quickly, with a lurid flame, producing muriatic acid and a deposition of charcoal.

23. In a similar mixture, contained in a long and wide glass cylinder, dip a copper wire loosely enveloped with Dutch gold, as in experiment 21. A very beautiful spontaneous combustion occurs, and vapours of muriatic acid, mixed with charcoal, produce thick black clouds, that settle on the sides of the vessel.

24. If a piece of charcoal is put into a cage of copper wire, and is set on fire by a blowpipe, and immersed into chlorine gas, the charcoal ceases to burn, but the copper wire takes fire; showing the strong tendency of the chlorine to combine with the metal, and its indifference towards carbon.

25. *Illustrations of the Art of Bleaching.*—Add a few drops of water to a quantity of chlorine gas contained in a bottle, and suspend some coloured flowers in the midst of the moistened gas. In a short time, the flowers will be deprived of their colours. This bleaching property is not possessed by dry chlorine gas. In all probability, the effect produced in this experiment is owing to the formation of peroxide of hydrogen. See page 249.

26. Put into a phial of liquid chlorine, strips of linen or cotton cloth, dyed of different colours. The colours will be quickly discharged.

27. A solution of chlorine discharges the blue colour of the solution of sulphate of indigo.

28. Litmus paper is bleached by solution of chlorine.

29. Writing done on paper with common ink is effaced when the paper is held in moistened chlorine gas.

30. *Bleaching Power of Chloride of Lime.*—Make a clear solution of chloride of lime, or bleaching powder, and immerse a strip of pink-coloured paper in it. The paper will come out white. Linen cloth stained by fruit or wine is purified from the stains by the same solution.

31. *Bleaching Liquor.*—Into a bottle of chlorine gas pour a little milk of lime and shake it. The green gas disappears, becoming absorbed by the lime, which is then in the condition of a bleaching liquor. If an acid is added to a little of this liquor, the chlorine is disengaged.

32. *Extemporaneous Formation of a Bleaching Liquid.*—Add a few grains of chlorate of potash to a few septems of muriatic or sulphuric acid diluted with half a test glassful of water. The liquid thus formed will possess the bleaching property of that described in the preceding paragraph. This experiment must not be made with large quantities of materials, because an explosion might occur.

33. *Test for Chlorine.*—Put a little chlorine water into a test glass, and add a few drops of a solution of nitrate of silver. A white curdy precipitate is formed, which is chloride of silver. This precipitate is soluble in ammonia, but not in nitric acid. It turns black on exposure to light. See pages 91 and 92.



510.

34. *Oxidising Action of Chlorine.*—See page 155 for experiment and theory.

HYDROCHLORIC ACID.

Formula, HCl; *Equivalent*, 36.5; *Specific gravity of gas*, 18.25; *Atomic measure*, 2 volumes.

Synonymes, *Muriatic Acid*, *Chlorhydric Acid*, *Spirit of Salt*; Systematic name, *Hydra chlora*.

Properties.—A colourless gas, sp. gr., 18.25; atomic volume, 2. Fumes in moist air; tastes sour and corrosive; has a pungent and peculiar odour; extinguishes flame; is destructive of animal life; reddens litmus; is incombustible; capable of reduction to the liquid state by cold and pressure; absorbed in large quantity by water, *i. e.*, one volume of water will absorb nearly 500 volumes of muriatic acid gas, producing a liquid acid of the specific gravity of about 1.2. This solution, when pure, is colourless, but owing to impurities, the muriatic acid of commerce has usually a straw colour. The usual impurities are iron, chlorine, nitrous gas, organic matters, sulphuric acid, sulphurous acid, and arsenic acid. Hydrochloric acid is always procured from common salt, and hence has been called *spirit of salt*. It is an acid that is much used in the arts and chemical laboratories, because of its great solvent power and of the solubility in water of many of its important salts.

Preparation of Hydrochloric Acid Gas.—The source of hydrochloric acid, or, strictly speaking, the source of its chlorine, is common kitchen salt (sea salt, rock salt, chloride of sodium). This substance, NaCl, contains 23 parts of sodium to 35.5 parts of chlorine. It is easily decomposed by oil of vitriol, and the products of the decomposition are as follows:—

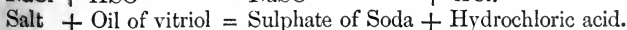

That is to say, 1 equivalent of chloride of sodium, and 1 equivalent of hydrate of sulphuric acid, produce 1 equivalent of sulphate of soda and 1 equivalent of hydrochloric acid, which is disengaged in the state of gas.

Put 6 parts by weight of pure salt into a gas bottle, and add a mixture containing 10 parts of oil of vitriol and 4 parts of water, previously mixed and cooled. Adapt the gas-leading tube by means of a vulcanised caoutchouc cap, and apply a gentle heat, upon which the hydro-

chloric acid gas will be given off. This gas, being soluble in water, must be collected over mercury, or, being a little heavier than atmospheric air, by the method of *displacement*, described at page 593. When the gas is required pure and dry, it may be passed through concentrated sulphuric acid contained in a V-tube, and afterwards through a tube filled with lumps of pumice-stone, moistened with concentrated sulphuric acid. The instructions given between pages 317 and 322 for the preparation and management of ammonia, a gas which, like hydrochloric acid, is extremely soluble in water, apply in most particulars to the preparation and management of hydrochloric acid, modified only by the changes that are demanded by the circumstance that ammonia gas is *lighter* than air, and hydrochloric acid gas *heavier* than air.

Experiments with Hydrochloric Acid Gas.

1. Fill a long tube with hydrochloric acid gas. Insert the open end of it into a basin of water coloured blue by litmus. The water will rush up into the tube, absorbing the whole of the gas, and acquiring a red colour from the presence of the dissolved acid. See page 320, experiment 1.

2. Perform the same experiment by means of the fountain bottle described at page 321, experiment 2.

3. Bring a glass containing ammonia gas mouth to mouth with a



511.

glass containing hydrochloric acid gas. White fumes will appear, and settle as a powder on the interior of the glasses. This is sal ammoniac. If a little of it is put into a wine-glass with lime, it discharges ammonia gas, perceived by the smell. If a little is treated with oil of vitriol, it disengages hydrochloric acid gas. If any two vessels disengaging ammonia and hydrochloric acid are brought near to each other the gases combine, as represented in fig. 511, and produce a white smoke of hydrochlorate of ammonia.

4. Fill a wide-mouthed bottle with dry hydrochloric acid gas by displacement, and close it with a greased plate of glass, *b*, fig. 512. Fill a similar bottle with dry ammonia gas by displacement (see page 320), and close it with a glass plate, *a*, fig. 512. Put the two bottles closed, with their plates, mouth to mouth together, as represented in the figure. If the plates fit the bottles air-tight, both bottles will appear to be empty. Suddenly take away the two glass plates, *a b*, and put the bottle



512.

directly mouth to mouth, upon which the two gases will instantly combine with one another, and fill both vessels with a cloud of ammoniac.

5. This experiment may be performed in a more homely way by warming a mixture of salt and sulphuric acid in a porcelain capsule, and when the acid gas rises in white fumes, waving in those fumes a feather dipped into liquid ammonia. This reaction is so prompt and perceptible that each of these gases is a delicate test for the presence of the other.

6. An inflamed taper is extinguished by this gas.

7. A bit of ice held in hydrochloric acid gas very soon melts. The ice may be suspended in a tall test-glass above a mixture of salt and sulphuric acid. If the ice is thrown up into dry gas over mercury, it dissolves and absorbs the gas instantly.

8. The production of hydrochloric acid gas, by the combination of chlorine gas with hydrogen gas, has been already described, page 667, experiments 19, 20, 21.

9. *Analysis of Hydrochloric Acid Gas, and liberation of its Hydrogen.*

—Put into a tube-retort (fig. 513) a measured quantity of dry hydrochloric acid gas over mercury. Pass up into it, by means of an iron wire, a small piece of metallic sodium. Heat the sodium in the gas by the application of a spirit-lamp, upon which it burns vividly. Decomposition of the gas takes place; half its volume disappears; the residue of the gas is hydrogen; and the sodium is changed into chloride of sodium. Hence two volumes of hydrochloric acid gas contain one volume of hydrogen and one volume of chlorine, combined without condensation, $H + Cl = HCl$. An equivalent of metal is in this case, and in all cases, required to replace the equivalent of hydrogen; so that $HCl + Na$ becomes $NaCl + H$.

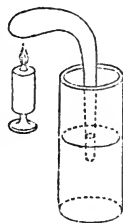

513

10. *Liberation of Chlorine from Gaseous Hydrochloric Acid.*—A current of hydrochloric acid gas is passed through a bent tube filled with chloride of calcium to dry it, and thence into a tube similar in form to fig. 514, but having the bulbs made further apart. The gas enters at *a* and passes out at *b*, which is inserted into a flask in which a large piece of moistened blue litmus paper is suspended. The bulb *c* contains roughly pounded peroxide of manganese. The hydrochloric acid gas, passing from *b* into the flask, reddens the blue litmus. Heat is then applied to the bulb *c*, upon which this decomposition takes place:—

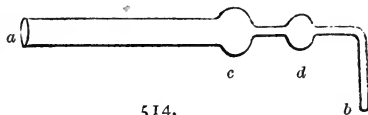

514.

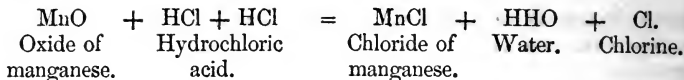

The MnCl remains in the bulb *c*; the water condenses in the bulb *d*; the chlorine passes from *b* into the flask, where it shows its green colour, and bleaches the litmus paper.

PREPARATION OF SOLUTION OF HYDROCHLORIC ACID.

The solution of hydrochloric acid gas in water, constituting what is commonly called muriatic acid and spirit of salt, is one of the most indispensable agents of a chemical laboratory.

Mitscherlich's Apparatus.—The solution of hydrochloric acid is prepared by passing a slow current of the gas into cold water, contained in a flask. Fig. 515 shows the apparatus recommended by Mitscherlich to be used for this process, when a large quantity is required. *a* is a large glass balloon placed in a sand-bath; *b* a stopper of serpentine, turned to fit the neck of the balloon; *g* a receiver with a little water to wash the gas and intercept impurities; *h* the water that is to absorb the gas. The tubes are fastened into the stopper by a lute of clay and linseed-oil, and plaster of Paris is applied over the joint to close all apertures. See fig. 326, page 332. The acid is poured in portions through the funnel, *d*, upon the heated salt. No heat

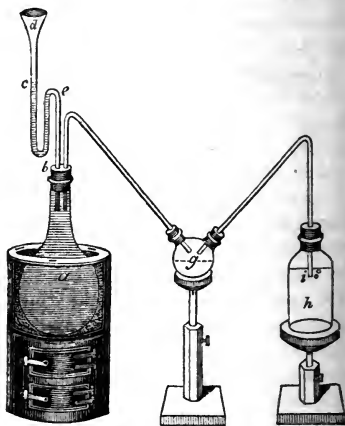

515.

is applied while the gas goes over without it. The bottle, *h*, is cooled externally by ice-cold water, because the condensation of the gas produces great heat. The gas-delivering tube is dipped but a very little way, say one-eighth of an inch, into the water, because the solution of muriatic acid sinks to the bottom as it is produced. The bottle, *h*, should be changed whenever the gas appears to rise through the water unabsorbed. Seven parts of water by measure produce ten parts of saturated solution of acid.

The delivery-tube may have a bulb blown near its highest part, to prevent the driving back of the absorbing water into the boiling flask, in the event of a vacuum occurring in the latter.

Regnault's Apparatus.—Equal parts of chloride of sodium and concentrated sulphuric acid, the latter diluted with one third of its weight of water, are put into a large globular flask, which is then connected with a series of Woulff's bottles, as represented by fig. 516. The first of these bottles is of small size, and contains only a little water to wash

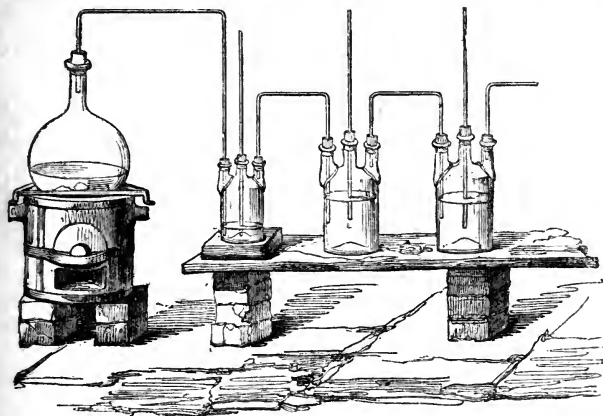

516.

the gas and separate its impurities. The other bottles, which are to absorb the acid, are two-thirds filled with water. The tubes which carry the gas dip but a little way into the water of each flask.

There is no advantage in this form of apparatus over that presented by fig. 515. On the contrary, the Woulff's bottle, with its fixed tubes, is difficult of management. The delivery-tube should never dip far into the absorbing water; and as the latter rapidly increases in bulk, namely, from 7 measures to 10 measures, it is convenient to be able to lower the position of its bottle, so as to keep the mouth of the tube always near the surface of the water. That is easily managed with a single loose bottle like *h*, fig. 515; but not so when we have to deal with such a rigid regiment of bottles as is shown in fig. 516.

Extent of the Solubility of Hydrochloric Acid Gas in Water.

The strongest hydrochloric acid that can be prepared at the temperature of 62° F. has the strength of nearly 94° , and a specific gravity of about 1.2. 711 septems of water produce 1000 septems of acid of this strength. There is a point of concentration at which this acid distils without alteration of strength. Professor Clark found its specific gravity to be 1.11. The chemical strength of it is about 48° . Weaker acids give off water when boiled, and stronger acids give off hydrochloric acid gas. Extremely little condensation is effected by

HYDROCHLORIC ACID. TABLE A.

Test Atom HCl = 36.5 grains.

Specific Gravity of the Acid.	Per Centage of Acid of 1.2.	Grains of HCl in 1 Septem.	Test Atoms of HCl in 1000 Septems.	Septems containing 1 Test Atom of HCl.	Septems containing 1 lb. of the Acid.
1.2	100	3.4253	93.8	10.7	833
1.198	99	3.3859	92.7	10.8	834
1.196	98	3.3467	91.7	10.9	836
1.195	97	3.3068	90.6	11.	837
1.193	96	3.2685	89.5	11.2	838
1.191	95	3.2296	88.5	11.3	840
1.182	90	3.0371	83.2	12.	846
1.162	80	2.6534	72.7	13.8	861
1.141	70	2.2798	62.5	16.	876
1.121	60	1.9162	52.5	19.	892
1.11	55	1.7428	47.7	21.	901
1.1	50	1.5699	43.	23.3	909
1.09	45	1.3999	38.4	26.	917
1.08	40	1.2328	33.8	29.6	926
1.06	30	.90743	24.9	40.2	943
1.05	25	.74904	20.5	48.8	952
1.04	20	.59351	16.3	61.3	962
1.03	15	.44088	12.1	82.6	971
1.02	10	.29117	7.98	125.3	980
1.01	5	.14416	3.95	253.2	990
1.004	2	.05735	1.57	636.9	996
1.002	1	.02862	.78	1282.	998
		.0365	1.	1000.	

If the strongest acid in the above Table is taken as the standard of money value, the values of the other acids will change with their per centage of the standard acid. Nitric acid, page 303, and the explanation at page 304.

diluting hydrochloric acid with water. The most useful strengths of the acid for laboratory use are 5°, and 10° for testing; 20° for preparing gases without heat, HS, &c.; and 50° or 60° for dissolving metals &c., with heat. Concentrated acid is only required for special experiments, such as the preparation of chlorine, and it cannot be preserved without loss.

Impurities of Commercial Hydrochloric Acid. Sulphuric Acid.—Dilute HCl with water, and add a solution of chloride of barium. A white precipitate indicates sulphuric acid. Sulphurous Acid.—Dilute HCl

HYDROCHLORIC ACID. TABLE B.

Test Atom HCl = 36.5 grains.

Grains of HCl in 1 Septem.	Test Atoms of HCl in 1000 Septems.	Septems containing 1 Test Atom of HCl.	Grains of HCl in 1 Septem.	Test Atoms of HCl in 1000 Septems.	Septems containing 1 Test Atom of HCl.
3.431	94	10.6	1.7885	49	20.4
3.3945	93	10.8	1.752	48	20.8
3.358	92	10.9	1.7155	47	21.3
3.3215	91	11.	1.679	46	21.7
3.285	90	11.1	1.6425	45	22.2
3.1025	85	11.8	1.606	44	22.7
2.92	80	12.5	1.5695	43	23.3
2.7375	75	13.3	1.533	42	23.8
2.555	70	14.3	1.4965	41	24.4
2.3725	65	15.4	1.46	40	25.
2.19	60	16.7	1.2775	35	28.6
2.1535	59	17.	1.095	30	33.3
2.117	58	17.2	.9125	25	40.
2.0805	57	17.5	.73	20	50.
2.044	56	17.9	.5475	15	66.7
2.0075	55	18.2	.365	10	100.
1.971	54	18.5	.219	6	167.
1.9345	53	18.9	.1825	5	200.
1.898	52	19.2	.146	4	250.
1.8615	51	19.6	.073	2	500.
1.825	50	20.	.0365	1	1000.

with water, add protochloride of tin, and boil: if sulphurous acid is present the liquor turns brown or gives a black precipitate. *Arsenic*.—See page 653. *Neutral Salts* (NaCl and NaSO²).—Evaporate HCl to dryness on platinum foil. Nothing should remain. *Chlorine*.—Dissolves gold-leaf. Known by its odour. *Ferric Chloride*.—It gives the acid a yellow colour. Nearly neutralise the acid with ammonia, and test with yellow prussiate of potash, which gives a blue precipitate.

To purify Commercial Hydrochloric Acid.—Dilute it to sp. gr. 1.11, or to 48°, add a little chloride of tin in crystals, or a few pieces of granulated tin, and distil the acid from a retort into a receiver, or by means of such an apparatus as that shown by fig. 243, page 241. The first and last portions that distil over are least pure. The intermediate portion is the purest.

TESTING OF THE STRENGTH OR DEGREE OF HYDROCHLORIC ACID.

1. *By Ammonia of 10°*.—The process is exactly the same as that for testing nitric acid by ammonia of 10°, as described at page 110, except that 10 septems of acid may be taken for trial instead of 5 septems. As the greatest strength of hydrochloric acid at 62° F. is below 94°, the greatest quantity of ammonia of 10° which can be required to saturate 10 septems of the acid will be under 94 septems.

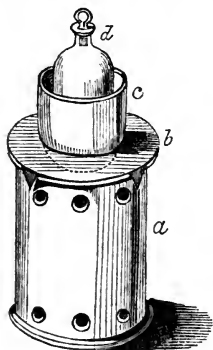

517.

2. *Testing of Hydrochloric Acid by means of a solution of Nitrate of Silver*.—1. Prepare a solution of pure nitrate of silver of 1° of strength by dissolving 170 grains in 1 decigram of solution.—2. Dilute the hydrochloric acid that is to be examined to 10 times its volume.—3. Prepare the following apparatus: *a* is a cylinder containing a spirit-lamp; *b* a perforated iron top; *c* a porcelain water bath containing a little hot water; *d* a bottle with

an accurately-fitted stopper, and of the capacity of 250 septems (4 fluid ounces).—4. Put into the bottle *d*, 100 septems of water, 12 drops of solution of litmus, and 10 septems of the tenfold diluted hydrochloric acid. Close the bottle with its stopper, after first dipping the latter into pure water.—5. Fill the centigrade test-tube, fig. 76, page 100, with the solution of nitrate of silver of 1°, adjusting the measure with accuracy, as pointed out at page 99.—6. Then pour the nitrate of silver from the test-tube into the bottle *d*, until it ceases to produce a precipitate of chloride of silver. The solution in the bottle *d* must be kept pretty hot. After each addition of nitrate of silver, the bottle is to be stoppered, put into a cylindrical case of brown paper, and to be vigorously shaken, the bottle being held firmly in the right hand, with one finger fixed on the stopper. This agitation causes the chloride of silver to coagulate and precipitate, leaving a clear liquor, which can be tested by a single drop of nitrate of silver. If a cloudiness appears, more nitrate of silver is to be added, and the whole is to be heated and again shaken. This is to be continued until the nitrate of silver ceases to cause a precipitate to be formed.—7. The accuracy of the analysis may be checked by repeating the operations described in 4, 5, 6. RESULT:—The number of septems of nitrate of silver required to precipitate 10 septems of the diluted hydrochloric acid gives the strength of the undiluted hydrochloric acid, expressed in degrees. The calculation is explained at pages 109 and 110.

Preparation of Hydrochloric Acid of specific degrees of strength.—Test the acid by the preceding methods. Then find the atomic measure of

the tested acid; that is to say, find how many septems of it contain 1 test atom, or 36.5 grains of real acid HCl. For that purpose, consult the two tables of Hydrochloric Acid, or calculate the number by the methods described at page 306. By proper dilution in the test-mixer, acid of any given strength is then readily prepared. Thus, if you have stock acid of 90°, corresponding to sp. gr. 1.94, then 11.1 septems of that acid diluted to 100 septems produce acid of 10°, and diluted to 200 septems produce acid of 5°. The manipulations respecting such dilutions are described at page 105.

HYDROCHLORIC ACID CONSIDERED AS A SOLVENT.

Sp. gr. 1.12 or 1.13. Strength, 50° to 60°.

Solutions in hydrochloric acid are commonly effected with the aid of heat and in acid of about the sp. gr. of 1.12 to 1.13, to which water is added upon particular occasions. In a great many cases hydrochloric acid is as powerful a solvent as nitric acid, and it has the advantages of being much cheaper, and of permitting, far more readily than nitric acid does, the expulsion, by evaporation, of any superfluity of acid that may be present in a solution. On the other hand, it forms, with silver, lead, and a few other substances of frequent occurrence, insoluble compounds where the compounds formed by nitric acid are all soluble, and, therefore, fit for subsequent examination by testing. It dissolves also fewer metals and sulphates than nitric acid. On this account hydrochloric acid can be employed as a solvent only when the substance to be examined is known to be one that will give soluble compounds with this acid, or in cases where the absence of nitric acid or the presence of chlorine is required in the solution to bring about particular objects.

Things to be observed regarding this Solution.

1. The solution takes place in diluted or concentrated acid, cold or with heat.
2. *Hydrogen Gas* is disengaged, indicating the presence of iron, zinc, cobalt, nickel, cadmium, and tin, all of which metals decompose diluted hydrochloric acid at common temperatures, and produce soluble metallic chlorides.
3. *Chlorine Gas* is disengaged, as is known by its colour, odour, and bleaching action on wet litmus paper. This indicates the presence of a metallic peroxide, as of lead and manganese, or of

Chromic acid,	Chloric acid,	Manganic acid,
Vanadic acid,	Bromic acid,	Permanganic acid,
Selenic acid,	Iodic acid,	Nitric acid.
4. *Sulphuretted Hydrogen Gas* and *Seleniuretted Hydrogen Gas* are disengaged. They are detected by their odour and by the blackening of a piece of paper wetted with a solution of lead. They indicate the presence of easily soluble sulphides and selenides.
5. *Arseniuretted Hydrogen Gas*, which is known by its very stinking odour, dangerous to smell, and by the white precipitate which appears when this gas is conveyed into a solution of corrosive sublimate, is disengaged during the solution of metallic arsenides.
6. *Carbonic Acid Gas* is disengaged with effervescence from cold, and not too dilute, hydrochloric acid, from nearly all carbonates, a few of which, however, drawn from the mineral kingdom, such as magnesite and sparry iron ore, require warm hydrochloric acid for their solution.
7. When the solution of the unknown substance is only effected *partially*, the undissolved residue may be a mixed substance, such as silica, more rarely sulphur, and oftener a product of the operation, as chloride of silver, protochloride of mercury, and chloride of lead, of which chlorides the last alone dissolves upon a large addition of water.

8. When the addition of water to the clear acid solution produces a *precipitate*, the solution may be expected to contain antimony, tellurium, or bismuth.

9. The *colour* of the solution often indicates the metal that is present. See page 212.

10. The *neutrality* of the solution must be tried. Only the alkaline earths can produce fully neutral solutions. When the solution appears to be very acid, in consequence of containing a great excess of acid, this must be separated by evaporation before any alkaline reagents can be applied to the solution, otherwise double chloride will be formed, which will vitiate the action of the tests upon the metals that may be present.

11. The precautions stated in article 15, page 311, against mistaking certain insoluble salts for the bases of the same salts, apply also to the solutions here under consideration.

Substances Soluble in Hydrochloric Acid.

Metals, namely, all those which decompose water at common temperature, or at a red-heat. The solution is effected in *diluted* hydrochloric acid, and with evolution of hydrogen gas. These metals are as follows:—

Metals of the Alkalies	} Of very rare occurrence.
Metals of the Earths	
Manganese	
Cadmium. Cobalt. Nickel.	

Zinc. Iron. Tin.

Tin, readily }
Copper, slowly } in hot concentrated acid.

Lead }
Bismuth } Very slightly soluble in hot
Antimony } concentrated acid.

Arsenic }
Sulphides, soluble in hot and not very dilute acid, under disengagement of sulphuretted hydrogen gas, namely those of the Metals of the Earths.

Metals of the Alkalies—

Manganese	Iron
Cobalt	Cadmium
Nickel	Antimony
Zinc	

Phosphides } of the same metals as the
Selenides } sulphides.

Metallic Oxides. All such as commonly produce salts, except those of

Silver }
Mercury } quite insoluble.

Lead }
Bismuth } nearly insoluble.
Antimony }
Tellurium }

Earths—the whole of them, even Silic when separated from silicates by greatly diluted acid.

Metallic Peroxides, sometimes they require hot and strong acid.

Chlorides }
Bromides } except Fluorspar, Fluosilicic
Iodides } of Barium, and the com
Fluorides } pounds of the metals which
Cyanides } give insoluble chlorides.

Salts of Non-metallic Acids—most of those which do not dissolve in water, excepting the sulphate of Barytes, the sulphate of Strontian, and salts whose metals give Insoluble chlorides.

Salts of Metallic Acids—many of them.
Silicates. The bases of many siliceous minerals are dissolved, while the silic remains undissolved, or is only very slightly dissolved.

Substances Insoluble in Hydrochloric Acid.

Charcoal.

Sulphur.

Selenium.

Metals which do not decompose water,

i. e. :—

Mercury	Gold	} are not dissolved at all.
Silver	Titanium	
Palladium	Uranium	
Rhodium	Molybdenum	
Platinum	Tungstenum	
Iridium		

Lead }
Bismuth } an extremely small quantity
Antimony } dissolved.
Tellurium }

Arsenic }
Sulphides. Those of the metals which do not decompose water; except new precipitated sulphides which are slightly soluble.

Iron pyrites.
Tin, persulphide.

Ignited Earths and Oxides, such as Alumina, Zirconia, Oxide of Tin and Protoxide of Chromium, dissolve very slightly and slowly.

Metallic Acids which do not dissolve in water, namely the acids of

Silicon Tungsten
Titanium Tantalum

but

Antimoniac acid
Antimonious acid
Arsenious acid

are soluble in concentrated acid, and precipitable therefrom by water.

Silver } all their compounds are insoluble.
Mercury } ble.

Lead, its compounds but slightly soluble, and only in diluted acid.

Bismuth
Copper, protoxide
Antimony
Tellurium

} Only soluble in concentrated acid and mostly precipitable by water.

Silicates, mostly insoluble, especially those with excess of silica; but many suffer decomposition and deposit silica.

Sulphate of Barytes.
Seleniate of Barytes.

Sulphate of Strontian.
Seleniate of Strontian.

Fluorspar.

Fluosilicide of Barium
Sulphate of Lead
Sulphate of Lime

} nearly insoluble.

Decomposition of Siliceous Minerals by Hydrochloric Acid.

The decomposition of native silicates by hydrochloric acid is effected with different phenomena dependent upon the nature of the mineral. When the finely-pulverised substance is mixed with cold hydrochloric acid in a state of concentration, the decomposition often occurs on the instant, a great deal of heat is produced, and the mass congeals into gelatinous lumps. If water is then added, the metallic bases of the decomposed silicate dissolve in the state of chlorides, while the silica appears in the form of tender flocks. The minerals termed ZEOLITES, which occur so plentifully in the neighbourhood of Glasgow, are decomposable in this manner, especially such of them as contain water of crystallisation. Yet it is to be observed that when these minerals have undergone exposure to a red heat, they are no longer soluble in hydrochloric acid.

There is another class of silicates which are only decomposable by a prolonged digestion with hydrochloric acid; in which case there is no production of jelly or of gelatinous lumps; the silica is then separated in the form of fine white powder.

The following is a list of the siliceous minerals which are decomposable by hydrochloric acid. Of these, the first 35 produce a jelly when finely powdered and treated with an excess of concentrated hydrochloric acid, while this is not the case with the last 10, several of which can only be fully decomposed by a very long and very hot digestion, and after a most careful pulverisation:—

- | | | |
|----------------------|--------------------------|------------------------|
| 1. Apophyllite. | 17. Nephelin. | 32. Sideroschisolite. |
| 2. Natrolite. | 18. Mellinite. | 33. Hisingerite. |
| 3. Scolezite. | 19. Chabasite. | 34. Diopase. |
| 4. Mesolite. | 20. Pectolite. | 35. Meerschaum. |
| 5. Mesole. | 21. Okenite. | — |
| 6. Analcime. | 22. Davyne. | 36. Copper green. |
| 7. Laumonite. | 23. Gadolinite. | 37. Stilbite. |
| 8. Potash harmatome. | 24. Allophane. | 38. Epistilbite. |
| 9. Leucite. | 25. Helvine. | 39. Heulandite. |
| 10. Elaeolite. | 26. Datholite. | 40. Anorthite. |
| 11. Brewsterite. | 27. Botryolite. | 41. Titanite (Sphene). |
| 12. Cronstedite. | 28. Eudialite. | 42. Pyrosmalite. |
| 13. Ilvaite. | 29. Orthite. | 43. Cerite. |
| 14. Gehlenite. | 30. Silicate of zinc. | 44. Cerin. |
| 15. Wernerite. | 31. Silicate of bismuth. | 45. Alanite. |
| 16. Tabular spar. | | |

EXPERIMENTS ILLUSTRATING THE PROPERTIES OF HYDROCHLORIC ACID.

1. Metallic iron mixed with solution of hydrochloric acid dissolves under disengagement of hydrogen gas. See page 192. Filter the solution while hot through a wet filter into a narrow-necked bottle, and allow it to crystallise. The solid green crystals produced are ferrous chloride = FeCl. The reaction in this experiment is as follows:—



2. Dissolve sesquioxide of iron in hydrochloric acid: No gas is set free. The solution on evaporation gives a brown mass. This is ferric chloride = FecCl. The reaction here is:—



3. Dissolve some of the crystals of ferrous chloride in water, add a small quantity of chlorine water, and boil the mixture. The product is again ferric chloride = FecCl. The reaction has been explained at page 155. It may be stated thus:—

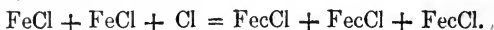

Namely, two ferrous atoms are converted into three ferric atoms, and so require and take up the third atom of chlorine.

Under all similar circumstances, in considering the constitution of the chlorides, we are to take, as our *standard of comparison*, one atom of 35.5 parts of chlorine. As much of a metal as combines with that quantity of chlorine produces a neutral chloride. The two chlorides of iron are equally neutral. Each contains 35.5 of chlorine; but in the ferrous salt, Fe weighs 28, while in the ferric salt Fec weighs 18. Each of these quantities of iron is a true chemical radical. Fec is always equivalent in neutralising action to Fe.

4. Dissolve a little caustic soda in water; test it with litmus paper which it changes from red to blue. Add to it hydrochloric acid, drop by drop, till the solution ceases to change the colour of the litmus paper. This experiment may be made promptly with solutions of the two liquors graduated to 5° or 10°. See page 118. When thus neutralised the liquor will neither taste alkaline nor acid, but purely salt; and if it is slowly evaporated, it will give cubical crystals of common salt. This reaction is as follows:—

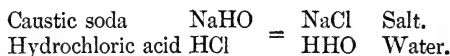

5. In two large glasses of water, put a few drops of solution of nitrate of silver and of hydrochloric acid. The water remains perfectly clear, but if they are mixed together in any proportions, they give a milky precipitate of chloride of silver = AgCl. If the mixed milk

liquor is heated and shaken, the chloride of silver agglomerates. This reaction may be stated as follows:—

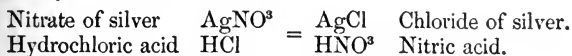

CHLORIDES.—A chloride is a salt composed of chlorine combined with a basic radical = $M + Cl$. Hydrochloric acid is a true chloride = $H + Cl$, and its hydrogen is replaceable by any basic radical whatever, simple or compound. The five experiments which I have just described show various methods by which the hydrogen of chloride of hydrogen is displaced by other radicals. The experiments which illustrate the properties of chlorine, see page 666, exhibit other means of preparing chlorides; and numberless examples of similar reactions have been detailed in other parts of this work.

Most of the chlorides are single salts, but a variety of double and triple chlorides exist. See *Radical Theory in Chemistry*, page 188. There are no grounds for assuming the existence of such compounds as $M + Cl^2$ and $M + Cl^3$, unless MCl^2 is a radical. See page 623.

Reduction of Metallic Oxides by Chlorine.—Dry hydrochloric acid gas and dry chlorine gas are sometimes used by the analytical chemist to decompose metallic oxides, and convert them into chlorides, or to separate metals from one another by producing chlorides of different degrees of volatility. The following apparatus is employed. The gas

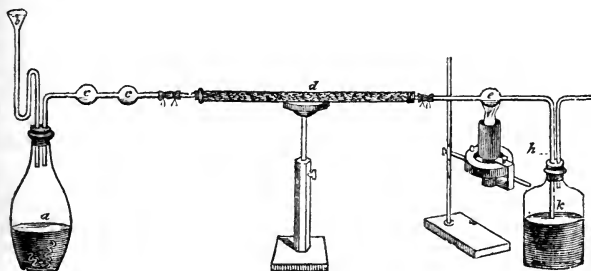

518.

is produced in the flask *a*, and is dried in the tubes *c* and *d*. The metals to be converted into chlorides are put into the bulb *e*, and heated by the lamp placed below. The gas being then driven over, the oxides or metals are converted into chlorides, and the volatile chloride is driven into the flask *k*, while the non-volatile chloride remains in the bulb tube *e*. When oxygen is set free, it passes off by the open tube in *k*.

Detection of Chlorides.—See page 92. The metallic chlorides are all soluble in water, except chloride of silver, and the cuprous, mercurous,

aurous, and platinous chlorides. The chloride of lead is only soluble in a large quantity of water.

THE CHLORATES.

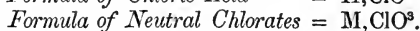
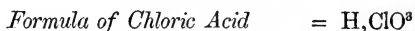

If we compare the chlorates with the chlorides and nitrates we perceive the following relations and differences:—

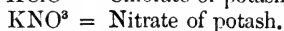
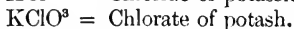

The chlorates differ from the chlorides by containing three atoms of oxygen. They differ from the nitrates by containing Cl instead of N, all other things remaining the same. If the hydrated chloric acid formed the chloric anhydride, the decomposition would take place thus:—

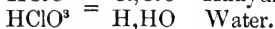

But the anhydride of this acid has not yet been discovered.

Properties of the Chlorates.—They are all simple salts, agreeing with the formula MClO^3 . They deflagrate when heated on charcoal. When ignited, they give off oxygen gas, and are generally converted into metallic chlorides. See page 160. They are all soluble in water, and give no precipitate with a solution of nitrate of silver; but *after ignition*, by which they are converted into chlorides, they do give a precipitate of chloride of silver. They burn and explode with great violence when mixed with combustible substances and then struck or heated. I shall describe these experiments when treating of the salts of potassium.

Chlorate of Potash.—As this is the model salt of the series, I shall describe the method of preparing it. Pass chlorine gas into a solution of caustic potash to saturation, and heat the mixture. Two different salts are produced by this reaction, as shown in the following equation:—

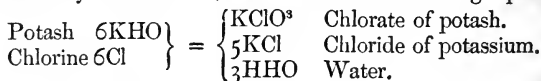

The chlorate of potash is much less soluble in water than the chloride of potassium, in consequence of which it crystallises first, but in a state of admixture with some of the chloride. It is redissolved and recrystallised two or three times to get rid of the chloride. The test of purity is, that its solution gives no precipitate with a solution of nitrate of silver.

Chloric Acid = HClO^3 .—To obtain this acid, the chlorate of potash is decomposed by hydrofluosilicic acid, which forms an insoluble salt with the potash and liberates the chloric acid:—

Hydrofluosilicic acid HSi^2F^8 = KSi^2F^8 Fluosilicate of potash.
 Chlorate of potash KClO^3 = HClO^3 Hydrated chloric acid.

The chloric acid can be concentrated to a syrupy liquid, which is very acid and easy of decomposition by light, or heat, or contact with organic matter. It sets fire to paper.

Use of the Chlorates as Oxidising Agents.—Into a boiling solution of ferrous chloride, put a little chlorate of potash and some hydrochloric acid. The ferrous salts rapidly become ferric salts, according to the current theory by *oxidation*; according to the radical theory by quite another kind of reaction:—

First metamorphose:—



Second metamorphose:—



In the first place, one atom of chlorate of potash sets free six atoms of chlorine, because the three atoms of oxygen require six atoms of hydrogen to form water. See page 154. In the second place, these six atoms of free chlorine convert twelve ferrous atoms into eighteen ferric atoms, and produce eighteen atoms of ferric chloride. Thus one atom of chlorate of potash *nominally* OXIDISES eighteen atoms of ferric chloride, but *actually* there is no oxidation of anything save the transference of O^3 from the chlorate of potash to the hydrogen of the hydrochloric acid.

THE PERCHLORATES = M,ClO^4

THE CHLORITES = M,ClO^2 .

When chlorate of potash is heated, at a certain point it seems to be converted into these two salts:—

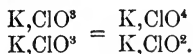

The perchlorate of potash is not decomposed at that degree of heat; but the chlorite of potash is at once decomposed into KCl and O^2 . If the process is stopped, the perchlorate of potash can be separated by solution and crystallisation from the more soluble chloride of potassium. As these salts are not important, I pass them over without further notice.

OXIDES OF CHLORINE.

Hypochlorous Acid.—Formula, Cl,ClO ; Equivalent, 87; Specific gravity of gas, 43.5; Atomic measure, 2 volumes.

Chlorous Acid.—Formula, Cl,ClO^2 ; Equivalent, 119; Specific gravity of gas, 39.67? Atomic measure, 3 volumes?

Chloric Oxide.—Formula, ClO^2 ; Equivalent, 67.5; Specific gravity of gas, 33.75; Atomic measure, 2 volumes.

The above compounds have received an abundance of names. According to the systematic nomenclature of this work they would be called :—

Cl, ClO	Chlora chlorate.
Cl, ClO^3	Chlora chlorite.
ClO^2	Chlorete.

The preparation and examination of these compounds is troublesome, unpleasant, and attended with danger, from their explosive properties. They are described in the larger works on chemistry, to which I must refer the reader for details, restricting the present note to some account of

Chloric Oxide, ClO^2 , also called *Peroxide of Chlorine*.—This is produced by the action of concentrated acids on chlorate of potash. A deep-red liquor, or a greenish-yellow gas, very explosive, and dangerous to experiment upon. The safest experiment is that pointed out by Böttger:—Put into a tall test-glass a quarter of an ounce of powdered chlorate of potash. Add two or three ounces of hydrochloric acid of sp. gr. 1.12, or of 50° . The mixture immediately acquires a deep-yellow colour, and in a few minutes a brisk disengagement of gas takes place. Throw in six or eight pieces of phosphorus as large as pins' heads, which will burn brilliantly under the liquid.—Another safe experiment is to mix a few grains of powdered chlorate of potash with a few drops of concentrated sulphuric acid, in a test-tube.



519.

Chlorous acid will appear in yellowish-green vapours. A bit of phosphorus, or a ball of sponge or tow dipped in ether, affixed to one end of a long wire bent in the middle at a right angle, may then be dipped into the vapour to cause an explosion to occur.

CHLORIDE OF NITROGEN.—Formed when chlorine gas is passed into a solution of sal ammoniac. A yellow oily liquid, violently explosive. Dulong and Davy were dangerously wounded by accidents attending its examination. I have explained, at page 263, the circumstances under which it is produced and how accidents from it may be prevented.

NITRO-MURIATIC ACID.—*Aqua Regia*.—This is a mixture of nitric acid and hydrochloric acid, usually employed to dissolve gold and platinum, to convert sulphur into sulphuric acid, and to decompose metallic sulphides. The relative proportions of the two acids differ according to the object to be accomplished. In general, there should be an excess of hydrochloric acid. The action exercised by nitromuriatic acid on metals appears to be as follows:—

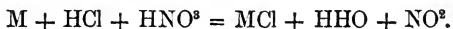

The products seem to point to these conclusions. The metallic chloride is formed in the solution, and a dark-red gas is given off, which appears

to be peroxide of nitrogen NO^2 . But, according to Gay Lussac, these red fumes contain two new compounds, one agreeing with the formula NCl^2O , the other with the formula NClO . The result as to the metal is, in any case, the formation of a chloride = MCl . Such a chloride can often be prepared with aqua regia when pure hydrochloric acid is quite powerless on the metal whose chloride is desired.

AQUA REGIA CONSIDERED AS A SOLVENT.

In general, aqua regia acts most effectually when it is composed of two parts of concentrated hydrochloric acid and one part of concentrated nitric acid; but these relative proportions are subject to variation. An excess of *hydrochloric acid* is required when the object in view is to produce metallic chlorides. An excess of *nitric acid* is required when the object is to oxidise sulphur or a metal. The two acids are to be mixed at the moment when the aqua regia is required for use. Some substances, such as sulphur and platinum, require for their solution a long-continued but not a very high degree of heat. The free chlorine which produces the chlorides, and the free peroxide of nitrogen which oxidises the sulphur or the metal, being volatile, are expelled by too strong a degree of heat.

The resulting solution commonly contains an excess of acid, free chlorine, and free nitrous acid, independently of the salt produced by the substance that is dissolved. From these extraneous compounds, the presence of which would disturb or destroy the subsequent reaction of such tests as alcalies, sulphuretted hydrogen, and prussiate of potash, it is necessary to free the solution by evaporation, driven either to dryness, or to what may be considered a sufficient degree of concentration.

A circumstance which attends this evaporation requires to be specially adverted to—it is, that when the solution contains a preponderance of hydrochloric acid, the evaporation expels the whole of the nitric acid; and when, on the contrary, an excess of nitric acid is present, the whole of the chlorine is expelled from the solution. It is, therefore, possible by this process to convert all nitrates into chlorides, and all chlorides into nitrates.

Metallic sulphides and selenides dissolve most readily when the dry substance is first treated with nitric acid, and the mixture is subsequently mingled with the requisite quantity of hydrochloric acid.

The metallic carbides, particularly cast-iron, dissolve better in aqua regia than in simple acids, because it separates more readily than they do the carbon from the metals.

In almost all cases the action of aqua regia is promoted by the application of heat.

Substances Soluble in Aqua Regia.

All metals, except

Rhodium

Iridium

Osmium-Iridium

} which are not
attacked.

Silver, which gives chloride of silver.

Titanium, which gives Titanic Acid.

Earths

Oxides

Peroxides

Salts

Phosphorus.

} All those which dissolve
either in Nitric acid or Hydro-
chloric acid alone, except the
compounds of silver.

Selenium.

Sulphur.

Metallic Phosphides

Metallic Selenides

Metallic Sulphides

{ Excepting those
whose metals are in-
soluble alone, or in
the state of chlorides;
but in this case, the
phosphorus, seleni-
um, or sulphur, is
acidified.

Substances Insoluble in Aqua Regia.

Charcoal.
 Earths } several, after strong
 Metallic Oxides } ignition.
 Metallic Acids, those which are insoluble
 in water: yet Arsenious acid is converted
 into Arsenic acid and dissolved, and
 Antimonious acid is slowly converted

into chloride of antimony which dis-
 solves.
 All substances not enumerated in these
 two Tables, and not soluble in nitric
 acid or hydrochloric acid alone, are in-
 soluble in aqua regia.

CHLORIDES OF SULPHUR.

Chloride of Sulphur.—Formula, ClS ; Equivalent, 51.5; Specific gravity of gas, 51.5; Atomic measure, 1 volume.

Dichloride of Sulphur.—Formula, ClS^2 ; Equivalent, 67.5; Specific gravity of gas, 67.5; Atomic measure, 1 volume.

To prepare the latter, ClS^2 , a current of dry chlorine gas is prepared by means of the apparatus figured at page 664, and is passed into the retort *c* depicted in this cut, by means of the tube *n*. In the retort *c* a quantity of sulphur is kept boiling by a lamp placed below. The tube *n* must be long enough nearly to touch the melted sulphur. The dry chlorine combines with the gaseous sulphur, and produces chloride of sulphur, which passes into the receiver, which must be perfectly dry and cooled externally. The tube *l*

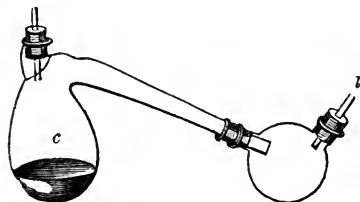

520.

is led into a chimney, or out of a window, to carry off the superfluous gases. Such an apparatus in a complete state is represented by figure 521. Chloride of sulphur is a reddish-yellow liquid of very unpleasant odour, fuming, volatile, heavier than water, by which it is decomposed.

The chloride ClS is produced by saturating the compound ClS^2 with chlorine. A dense deep-red fuming liquid.

CHLORIDES OF PHOSPHORUS.

Trichloride.—Formula, PCl^3 ; Equivalent, 137.5; Specific gravity of gas, 68.75; Atomic measure, 2 volumes.

Pentachloride.—Formula, PCl^5 ; Equivalent, 208.5; Specific gravity of gas, 69.5; Atomic measure, 3 volumes.

The atomic measures of these gases agree with the assumption made at page 138, that the measure of phosphorus in salts is half a volume, and that it reduces the measure of every radical in combination with it from 1 volume to half a volume. Hence, $\text{PCl}^3 = 2$ volumes, and $\text{PCl}^5 = 3$ volumes. The proper formulæ of the two compounds ought possibly to be $\text{PCl}^2 + \text{Cl}$ and $\text{PCl}^4 + \text{Cl}$.

The *Terchloride of Phosphorus* is prepared by the action of dry chlorine on dry phosphorus. It is a very volatile, transparent, colourless, fuming liquid. It is decomposed by water into phosphorous acid and hydrochloric acid :—

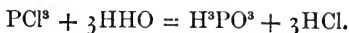

The apparatus employed to prepare the chlorides of phosphorus is represented in fig. 521. The chlorine gas is prepared in the flask A,

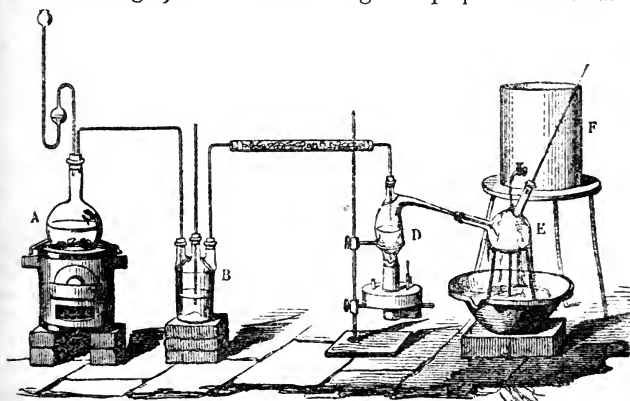

521.

washed in the bottle B, dried in the chloride of calcium tube, and then passed into the retort D by a long tube, which almost touches the substance that is to be acted upon. The volatile product distils over into the receiver E, where it is condensed by cold water from the cistern F. The phosphorus, which is heated in the retort D, rests upon a bed of sand, to keep the heat from the retort. When the *terchloride* is required, the phosphorus is heated very strongly, that the chlorine may act upon an atmosphere of phosphorus in excess. When the *pentachloride* is required, the heat must be less, and the chlorine be applied in excess.

The *Pentachloride* is a white crystalline solid, volatile under 212° F. It dissolves in water, producing phosphoric acid and hydrochloric acid :—

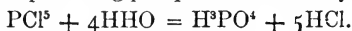

OXYCHLORIDE OF PHOSPHORUS = Cl^3PO , or perhaps PCl^2, ClO .— Equivalent, 153.5; Specific gravity of gas, 76.75; Atomic measure, 2 volumes. A limpid, volatile, fuming liquid; specific gravity, 1.7. Boils at 230° F. Produced, in company with hydrochloric acid, when steam mingles slowly with the pentachloride of phosphorus :—

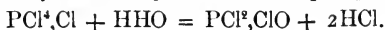

With more water, the oxychloride is decomposed into phosphoric acid and hydrochloric acid: $\text{PCl}^2, \text{ClO} + 2\text{HHO} = \text{HPO}^3 + 3\text{HCl}$.

The active energies of the chlorides of phosphorus qualify them to produce many striking metamorphoses among organic compounds, such as are shown by the following examples:—

1. $\text{H}, \text{C}^2\text{H}^5\text{O} + \text{PCl}^4, \text{Cl} = \text{C}^2\text{H}^5, \text{Cl} + \text{PCl}^2, \text{ClO} + \text{HCl}$.
Alcohol. Chloric ether.
2. $\text{C}^2\text{H}^2, \text{C}^2\text{H}^2\text{O}^3 + \text{PCl}^4, \text{Cl} = 2\text{C}^2\text{H}^2, \text{ClO} + \text{PCl}^2, \text{ClO}$.
Succinic anhydride. Oxychloride of succinyl.
3. $\text{H}, \text{C}^7\text{H}^5\text{O} + \text{PCl}^4, \text{Cl} = \text{C}^7\text{H}^5, \text{H}; \text{Cl}^2 + \text{PCl}^2, \text{ClO}$.
Essence of almonds. Bichloride of benzyl.
4. $\text{H}, \text{C}^7\text{H}^5\text{O}^2 + \text{PCl}^4, \text{Cl} = \text{C}^7\text{H}^5, \text{ClO} + \text{PCl}^2, \text{ClO} + \text{HCl}$.
Benzoic acid. Oxychloride of benzyl.
5. $3(\text{H}, \text{C}^2\text{H}^5\text{O}) + \text{PCl}^2, \text{Cl} = 3(\text{C}^2\text{H}^5, \text{Cl}) + \text{H}^3, \text{PO}^3$.
Alcohol. Chloride of ethyl. Phosphoric acid.

15. BROMINE.

Symbol, Br; *Equivalent*, 80; *Specific gravity of gas*, 80; *Atomic measure when isolated*, 1 volume; *Atomic measure when acting as a radical in salts*, 1 volume; *Condensing action on the atomic measure of other radicals*, 0; *Specific gravity in the liquid state at 32° F.*, 3·187.

Occurrence.—In sea water, in certain saline springs, in the water of the Dead Sea, and in small quantities in many minerals.

Preparation.—Bromine can be prepared from bromide of sodium by a process analogous to that by which chlorine is procured from chloride of sodium. A mixture of bromide of sodium, peroxide of manganese, and sulphuric acid diluted with its weight of water, is heated in a retort, upon which bromine distils over in vapour, and is condensed in a receiver to the liquid form. The apparatus suitable for this experiment is represented by fig. 522. The retort A is connected with the receiver C by the adapter B, all fitted closely with corks. As the vapour of bromine is excessively volatile and suffocating, the apparatus must be carefully closed. The retort is heated by a water-bath, and the receiver

is cooled by ice and iced water, of which there must be enough to produce an effectual condensation of the bromine.

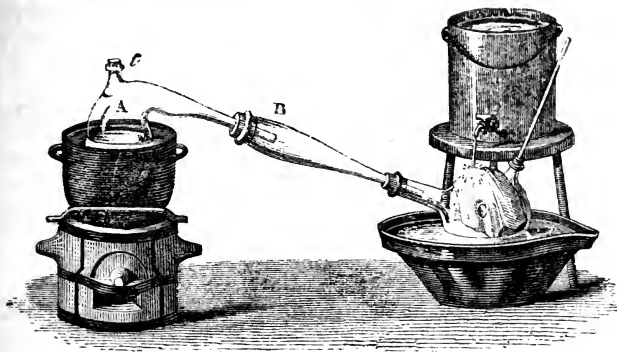

522.

Theory.—The reaction is precisely similar to that by which chlorine is liberated from its chloride:—

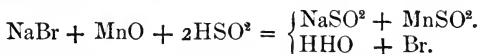

Compare this with the equation at No. 6, page 665.

Properties.—At the ordinary temperature of the atmosphere, bromine forms a dark reddish-brown liquid, which is heavier than water. Its sp. gr. at 60° is 2.97. It possesses a penetrating odour, which peculiarly and painfully affects the temples, and is thus distinguished from chlorine, which acts on the throat, and from iodine, which affects the nose. It boils at a low temperature, 146° F., and produces a reddish-brown gas, the sp. gr. of which is 80. Its atomic volume is 1. At -19° F. it freezes to a crystalline lead-grey semi-metallic mass. With a small quantity of water, it forms crystals; with a large quantity, it gives a hyacinth-red solution. It colours the skin yellow, and destroys it. It bleaches vegetable colours, and forms, with other elements, a series of compounds which much resemble those formed by chlorine.

Bromine is usually preserved in glass bottles with a little water above it. The bottle should be well stoppered, and kept in a dark place. The water becomes saturated with bromine, and forms a hydrate that very easily crystallises at a low temperature. When it crystallises, it expands considerably. Hence the bottle should never be kept full of liquid, as it is in danger of bursting the first cold night that occurs. The tension of bromine vapour is very great. If you take the stopper out of the bottle, the gas escapes from the saturated water, overflows the bottle, runs over the table, down upon the floor, and thence diffuses itself through the whole house. If you suffer the experiment to proceed

unmolested, all the bromine will thus pass through the water and escape.

When a given quantity of bromine is required for an operation, it can be conveniently measured by a tube, graduated to grains of water, like fig. 523. An elastic vulcanised caoutchouc ball is put on the top of this tube. A little air is forced out of the ball, the point of the tube is put, through the water, into the bromine, and then by relaxing the pressure of the hand on the ball, the bromine is sucked up into the tube measure. Every mark on the tube indicates 2·97, or nearly *three grains* of bromine, so that the quantity can be easily regulated. To weigh bromine by a balance is nearly impossible.

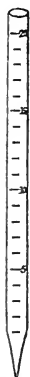

523.

THE BROMIDES.

Hydrobromic Acid = HBr. *Bromide of Potassium* = KBr. Exactly equivalent to hydrochloric acid HCl, and chloride of potassium KCl, both in constitution and chemical properties. Most of the bromides dissolve in water. Their solutions give white precipitates with solutions of nitrate of silver and of nitrate of lead. White starched cotton dipped into a solution containing a bromide acidified by hydrochloric acid, becomes yellow.

HYDROBROMIC ACID.

Formula, HBr; *Equivalent*, 81; *Specific gravity of gas*, 40·5; *Atomic measure*, 2 volumes; *Systematic name*, Hydra broma.

Nearly related in its properties to hydrochloric acid. An acid gas, which dissolves in water, producing liquid hydrobromic acid. The gas can be prepared pure as follows: Put into the bend *d* of the tube apparatus, represented by fig. 524,

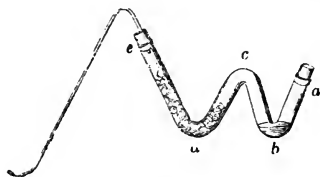

524.

some pieces of phosphorus. Fill the branch *d e* with fragments of glass wetted with water. Put into the bend *b* a little bromine. Close the necks *a* and *e*, and apply a very slight heat to the bromine at *b*. The bromine passes on to the phosphorus, and combines with it, forming the

compound PBr^2, Br . That immediately suffers decomposition from the water, and produces phosphorous acid, which remains in the tube, and hydrobromic acid, which goes off as gas, and may be collected over mercury, as shown by fig. 311, page 319:—

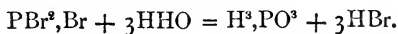

If too much water is put into the tube *e, d*, fig. 524, the gas will be absorbed, and produce liquid hydrobromic acid.

Hydrobromic acid gas is colourless; it is not combustible; it extinguishes flame; it is very irritating to the lungs. Its concentrated solution in water has a sp. gr. of 1.486, and distils unchanged. With metallic oxides, it produces bromides by double decomposition.



The bromates closely resemble the chlorates, but they are distinguished from them by giving a precipitate with a solution of nitrate of silver. The bromic anhydride = Br_2O^5 has not yet been discovered.

16. IODINE.

Symbol, I; Equivalent, 127; Specific gravity of gas, 127; Atomic measure when isolated, 1 volume; Atomic measure when acting as a radical in salts, 1 volume; Condensing action on the atomic measure of other radicals, 0; Specific gravity in the solid state, 4.948.

Occurrence.—It exists in sea water, and enters into the composition of sea-weeds, sponges, fuci, and algæ. These productions, when burnt, yield an alkaline ash, technically called *kelp*, which contains iodine in the state of iodide of sodium.

The compounds of iodine are quite similar to those of chlorine and bromine, so that I need not enter into minute details respecting them.

Preparation of Iodine.—Iodine can be prepared by a process similar to those employed for the extraction of chlorine and bromine. The apparatus is represented by fig. 525. Iodide of sodium, procured from

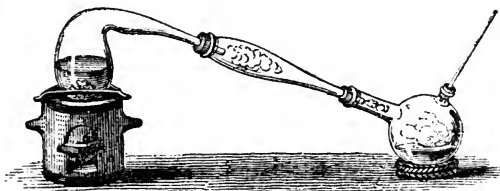

525.

kelp, is mixed with peroxide of manganese and diluted sulphuric acid, and is put into the retort and distilled. The iodine passes, in the state of vapour, into the receiver, and condenses to lead-coloured crystalline spangles of solid iodine. This element can also be precipitated in a

solution of iodide of potassium, by passing a current of chlorine gas into it. The iodine falls down as a gray powder. $KI + Cl = KCl + I$.

Properties.—Iodine, at common temperatures, forms soft pulverulent black semi-metallic crystals, which resemble plumbago. It is heavier than water. Sp. gr., 4.948. Its odour is something like that of chlorine, but weaker, and distinguished by the difference noted under Bromine. It fuses at a temperature a little above that of boiling water, 222° F.; and when strongly heated, volatilises in the form of a splendid violet-coloured gas. The sp. gr. of the gas is 127. Its taste is sharp and acrid; it is poisonous; it bleaches vegetable colours slightly; it colours the skin yellow, and makes paper brown, but the colours are fugacious. It is slightly soluble in water, 1 lb. of which dissolves 1 grain of iodine. The solution has a yellow colour, and the peculiar sea-side odour of iodine. It is readily soluble in alcohol and ether, producing brown solutions. It gives violet-coloured solutions with sulphide of carbon and mineral naphtha. It forms a blue compound with starch.

The compounds which iodine forms with other elements bear a great resemblance to the compounds produced by chlorine. In large doses it is poisonous. In small doses it is a valuable medicine for the cure of goitre, glandular swellings, &c.

Test for Iodine.—Starch that has been boiled in water, when put in contact with free iodine, loses its white colour, and becomes blue. Iodine in combination does not effect this change. There are different ways of applying the test. 1). Mix a little starch with the liquid supposed to contain iodine, and then add a few drops of nitric acid, or, what is better, a very little chlorine. The latter is done by inclining over the mixture a bottle that contains chlorine water. In such a bottle there is always a stratum of heavy chlorine gas floating above the liquor, and if the bottle is inclined, a portion of the gas flows out. This is preferable to adding the solution of chlorine, an excess of which is injurious. The solution must be cold. 2). Thick cotton thread is passed through a paste of starch prepared with hot water. It is dried, the superfluous starch is gently washed off in lukewarm water, and the cotton is again dried. This thread, which is perfectly white in colour, becomes *blue* when dipped into a solution that contains an extremely minute quantity of any compound of iodine; the solution being previously mixed with a few drops of nitric acid, or chlorine water. Starched paper answers the same purpose.

To form beautiful Crystals of Iodine.—Dissolve iodine in boiling alcohol, and let the solution cool. Splendid crystals, an inch and a half long, are produced in a few minutes. Fine crystals can also be produced by a slow sublimation. See page 57. This sublimation can be effected between two watch glasses.

Combustion of Potassium in Iodine.—Take a bent glass tube, which

is to be placed in a horizontal position. Put a little iodine at the bottom, and a bit of potassium in the middle of the tube. Volatilise the iodine by heat, and when the tube is full of its beautiful vapour, heat the potassium by holding a lamp below it. The metal will then burn with a violet light in an atmosphere of iodine. The product is iodide of potassium.



526.

Production of a Gas possessing a splendid Violet Colour.—Put a little iodine into a small flask, or a test-tube, and draw out the mouth of the



527.

vessel till the opening is extremely small. Then expose the flask to heat, upon which the iodine will rise in vapour, and, if in sufficient quantity, will expel the atmospheric air through the capillary opening, and fill the whole vessel, exhibiting a very beautiful appearance. By means of a blowpipe, the mouth of the vessel may now be sealed. When it cools, the violet vapour disappears, and the iodine is seen on the sides of the vessel in little crystals; but whenever the apparatus thus prepared is exposed to heat, the violet gas is again produced. A temporary apparatus may be prepared by means of a white glass balloon, which can be closed by a good cork, traversed by a very narrow glass tube, the outer end of which can be stopped at the proper moment by a little wax or soft cement.

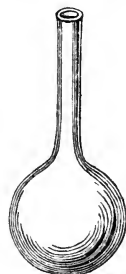

528.

HYDRIODIC ACID.

Formula, HI; *Equivalent*, 128; *Specific gravity of gas*, 64; *Atomic measure*, 2 volumes: *Systematic name*, Hydra ioda.

A colourless gas. Reddens litmus; smells very acid, like hydrochloric acid gas; suffocating; produces white clouds in the air; not combustible; condensable to the liquid state by pressure; dissolves in water rapidly and in large quantity.

Preparation of the Gas.—1). Phosphorus 1 part, and iodine 9 parts, are put into a tube apparatus, such as is depicted in fig. 529. Powdered glass, wetted with water, is stratified between the materials, in the order of iodine, glass, phosphorus, glass, &c., till the tube is two-thirds filled. A gentle heat is used, and the gas is collected over mercury.—2). Phosphorus 1 part, iodine 20 parts, iodide of potassium

14 parts, water a small quantity. The mixture is to be very gently warmed.—3). If iodine is heated in hydrogen gas, the hydrogen gas doubles its volume and becomes hydriodic acid gas.

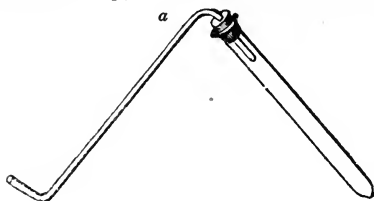

529.

Analysis.—1. If metallic potassium is heated in a measured quantity of dry hydriodic acid gas, it produces iodide of potassium and hydrogen gas, the volume of which is half the volume of the analysed hydriodic acid gas.

2. *Hydriodic Acid Gas is Decomposed by Chlorine Gas.*—Use two ten-ounce stoppered glass bottles with wide mouths. Fill one with chlorine gas and the other with hydriodic acid gas. When the decomposition is to be effected, take away the two stoppers, and put the bottles together mouth to mouth. The chlorine combines with the hydrogen, and the iodine is set free in the form of violet-coloured gas.

Preparation of the Acid in Solution.—Pass a current of pure sulphuretted hydrogen gas through water in which iodine is kept suspended by agitation. When the iodine is dissolved, and the solution becomes colourless, boil it to drive off the excess of sulphuretted hydrogen. Theory:— $I + HS = HI + S$. A colourless solution, which can be concentrated to sp. gr. 1.7, at which it can be distilled without losing gas. Possesses strong acid properties. It soon decomposes spontaneously.

IODIDES.—These compounds bear the same relation to hydriodic acid that the chlorides do to hydrochloric acid. Their composition is indicated by the formula MI. Hydriodic acid, with metallic oxides forms iodides and water. Thus: $HI + KHO = HHO + KI$.

Many of the metallic iodides possess very beautiful colours. See the precipitates produced by the iodide of potassium. Many iodides can be ignited without suffering decomposition. They are readily decomposed by chlorine, both at a red heat and when in solution. Concentrated sulphuric acid and bisulphate of potash, when heated, decompose iodides, and set iodine free. Some iodides (those of alkaline metals) dissolve in water; most of them are insoluble; and some of them are decomposed by it. They are poisonous.

Experiments.—1. Mix a solution of acetate of lead with a solution of iodide of potassium. A yellow powder appears. Boil the mixture. The powder disappears; but when the liquor cools, splendid gold-coloured spangles appear. 2. Paint with red iodide of mercury an figure on a piece of white pasteboard. Warm the pasteboard over spirit-lamp flame, when the red figure becomes yellow.

Detection of Iodides.—See page 93.

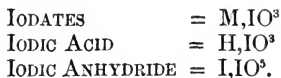

Preparation of Iodic Acid.—Heat one part of iodine with four parts of the most concentrated nitric acid. The heat must be gentle, to prevent a loss of iodine. The iodic acid forms small white grains. Evaporate these with the excess of nitric acid to dryness, and expose the product to the air at 60° F. until it has deliquesced. Remove the preparation to a warmer and drier place, upon which fine crystals of anhydrous iodic acid will be formed. The anhydrous acid, I,IO^3 , crystallises in six-sided tables. White, semi-transparent, heavier than oil of vitriol, reddens litmus. Very soluble in water, forming the hydrate HIO^3 . With metallic oxides, it forms the salts called IODATES.

Properties of Iodates.—A class of compounds that nearly resemble the Chlorates. Decomposed by heat, sometimes producing oxygen and Iodides, as $KIO^3 = KI + O^3$; sometimes producing metallic oxides, oxygen, and iodine, as $2BaIO^3 = BaBaO + I^2 + O^3$; and sometimes the metallic oxide retains a little *Periodic Acid*, $BaIO^4$. Most iodates deflagrate with red-hot charcoal. They are decomposed by sulphuric acid. Hence the hydrate of iodic acid can be prepared by adding sulphuric acid to iodate of barytes:—



IODIDE OF NITROGEN, $NI^2 + H$.—Rub powdered iodine in a mortar with liquid ammonia; after some time, filter the liquid. The filter paper will exhibit a dark-brown powder, which is the iodide of nitrogen. 1. It very often explodes spontaneously if dried in too warm a place, so that it requires cautious management. It should be divided, *while wet*, into small portions, and put on separate pieces of blotting-paper to dry. 2. It explodes if gently pressed with a hammer, producing a violent report, and a violet light. 3. It explodes in the same way when a bit of paper containing a small portion is lifted with the tongs and thrown on a fire. Consequently, experiments on this substance must be made with the utmost caution.

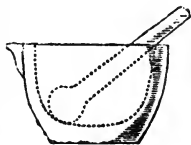

530.

MONA-CHLORIDE OF IODINE, ICl .—Liquid.

TRI-CHLORIDE OF IODINE, $ICl^2 + Cl$.—Solid.

1). Put dry iodine into a glass tube, and pass over it a current of dry chlorine gas, page 664, until the solid iodine becomes liquid. That product is ICl .—2). Continue to pass the current of dry chlorine gas for six hours. Apply heat to the product, and sublime it frequently. When completely saturated with chlorine, it is $ICl^2 + Cl$. The mona-chloride is a red-brown oily liquid, the vapour of which powerfully attacks the nose and eyes, and even makes the fingers smart. It

bleaches vegetable colours and indigo. It does not make starch blue. The tri-chloride forms orange-coloured crystals. It acts much like the mona-chloride. Both dissolve in water, with partial decomposition.

BROMIDE OF IODINE.—Add bromine, drop by drop, to an alcoholic solution of iodine, until the liquor acquires a fine red colour. Then dilute the mixture with water until it has a fine straw-yellow colour. This liquor can be preserved for occasional use; but it is necessary, from time to time, to add a little bromine water, because the bromine gradually escapes by evaporation.

17. FLUORINE.

Symbol, F; Equivalent, 19.

Occurrence.—It is a component of the mineral called *Fluorspar*, the composition of which is CaF . It also occurs in the mineral called *Kryolite*, which occurs in considerable quantities at Arksulfjord, in West Greenland, but in no other locality. Its composition is $\text{NaF} + \text{AlcF}$, which represents a double fluoride of sodium and aluminum. This mineral has lately been imported in quantities for the manufacture of metallic aluminum. Fluorine occurs in small quantities in other minerals, and in animal bones, the enamel of the teeth, &c.

Properties.—Fluorine has never been completely separated from other substances. All its compounds can be readily decomposed; but when the fluorine is liberated from one element, it instantly seizes upon another. It is like the Alchemists' Universal Solvent, which was to be able to dissolve *everything*, and which, therefore, must have dissolved the very vessels which they intended to put it in—when they had discovered it!

Compounds of Fluorine.—With hydrogen, it produces hydrofluoric acid; with metals, it produces fluorides. Hydrofluoric acid is a true fluoride, in which an equivalent of hydrogen occupies the place of an equivalent proportion of a metal. With boron and silicon, it forms compounds which will be noticed in their order. Fluorine has the peculiar property of not combining with oxygen.

HYDROFLUORIC ACID.

Symbol, HF; Equivalent, 20; Systematic name, Hydra fluora.

This acid is equivalent in composition to hydrochloric acid. It is composed of equal atoms of hydrogen and fluorine = $\text{H} + \text{F}$. It contains no oxygen. When the fluorine combines with a metal to form a fluoride, it gives up the hydrogen with which it is combined in the hydrofluoric acid = $\text{M} + \text{HF} = \text{MF} + \text{H}$.

Preparation.—Powdered fluorspar, free from silica, is gently heated

with twice its weight of oil of vitriol. The operation needs to be performed in vessels of platinum or lead, because the hydrofluoric acid decomposes glass and porcelain immediately upon coming into contact with them. Hence it must also be collected in metallic vessels. If concentrated hydrofluoric acid is required, no water is to be put into the receiver. If dilute acid is wanted, a little water may be put into the receiver to absorb the gas.

Figs. 531 and 532 represent two forms of apparatus for distilling hydrofluoric acid. Both are supposed to be made of lead, with joints ground to fit close together. Fig. 531 represents a retort and a bent

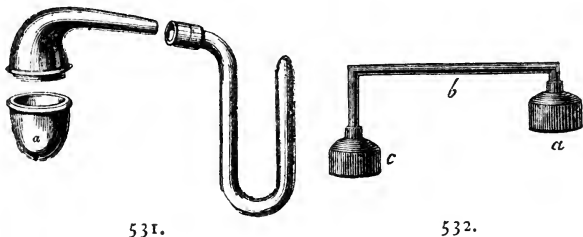

531.

532.

tube receiver. Fig. 532 represents a pair of bottles connected by a bent leaden pipe, the bottle *a* serving for a retort and the bottle *c* for a receiver. The receiver should be cooled by iced water.

The acid must be preserved in bottles of gutta percha, with stoppers of the same material, which should be sealed with resinous cement. If hydrofluoric acid gas escapes in any room where there is glass, the whole surface of the glass becomes corroded and is rendered opaque.

The dense acid ought never to be preserved.

Theory of the Production of Hydrofluoric Acid Gas:—



The fluoride of calcium is decomposed by the sulphuric acid, sulphate of lime is formed, and hydrofluoric acid is disengaged in the state of gas.

Properties of Hydrofluoric Acid.—A dense, fuming, volatile, colourless liquid, which boils at about 60° F. Soluble in water; intensely sour; reddens litmus, corrodes and dissolves glass, acts injuriously upon the organs of respiration, the vapours produce pain at the finger ends, and drops on the skin act like a red-hot iron, producing very painful sores. Used in mineral analyses.

To Engrave Figures on Glass.—Cover one side of a flat piece of glass, after having made it perfectly clean, with bees' wax, and trace figures upon it with a needle, taking care that every stroke cuts completely through the wax. Next, make a border of wax all round the glass, to

prevent any liquid when poured on from running off. Now, take some finely-powdered fluorspar, strew it evenly over the glass plate, upon the waxed side, and then gently pour upon it, so as not to displace the powder, as much sulphuric acid, diluted with twice its weight of water, as is sufficient to cover the powdered fluorspar. Let everything remain in this state for three hours, then remove the mixture, and clean the glass by washing it with oil of turpentine. The figures which were traced through the wax will be found engraven on the glass, while the parts which the wax covered will be uncorroded.

FLUORIDES. *Formula, MF.*—Hydrofluoric acid with metallic oxides produces metallic fluorides and water:—

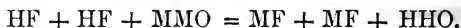

The fluorides of platinum, sodium, mercury, and silver, are soluble in water, but those of most other metals are insoluble. Some of the metallic fluorides combine with hydrofluoric acid and produce soluble double salts, such as $\text{KF} + \text{HF}$.

Detection of Fluorides.—See page 94.

18. BORON.

Symbol, B; Equivalent, 3.5. It does not form a gas, but its measure as a radical in gaseous salts is $\frac{1}{8}$ volume. It condenses every radical with which it combines to form gaseous salts, from 1 volume to $\frac{1}{2}$ volume.

Occurrence.—Boron is the acid radical of the salt called borax, or *tincal*, which is a mineral found in Thibet, and of boracic acid, which occurs in some hot springs in the volcanic districts of Tuscany.

Properties.—Boron is a dark olive-coloured powder, tasteless and inodorous. When heated in close vessels it shrivels up, but does not fuse nor volatilise. When heated in the air, it burns in a lively manner, and acquires a coating of dry boracic acid. Aqua regia and nitric acid convert it into boracic acid. Chlorine changes it into gaseous chloride of boron. When mixed and heated with nitrate of potash it explodes. The most important compounds of boron are boracic acid and borax.

BORACIC ACID, anhydrous = BBO. *Equivalent, 23.*

BORACIC ACID, crystallised = HBO. *Equivalent, 20.5.*

Preparation.—Dissolve three parts of borate of soda (borax) in twelve parts of hot water, and filter the solution; then add one part of sulphuric acid, by little and little, till the liquor has a sensibly acid taste. Put it aside to cool, and a great number of small laminated crystals (scales) will be gradually formed. These are boracic acid = HBO. They are to be purified by washing with cold water, which carries off any extraneous soluble body, but leaves the acid, which is

very sparingly soluble, almost untouched. When the crystals have been washed, they are to be drained upon filtering paper. They may be purified by solution and recrystallisation.

The hydrated boracic acid acts on blue colours like an acid, but on turmeric like an alkali. The crystals give off water when heated, and, at a red heat, fuse to a transparent colourless glass, which is used as a flux in analysis, and as an ingredient of false gems. It is the anhydrous acid = BBO. When heated to only 212° F., the crystals lose but half their water, and leave the compound $2\text{HBO} + \text{BBO}$. Boracic acid is obtained in the form of thin crystals or scales, of a silvery-white colour, which have a greasy feel, no smell, but a very strange taste—being first sourish, then bitterish, cooling, and at last agreeably sweet. It is soluble in water, but only in a slight degree. It is more soluble in alcohol, and gives to the flame of that body, when burning, a green colour.

Though sulphuric acid displaces boracic acid from borate of soda when in solution, yet if boracic acid is fused with sulphate of soda, sulphuric acid is expelled, and borate of soda reproduced.

Fusibility of Boracic Acid.—Melt a small quantity on a hooked platinum wire in the blowpipe flame, as represented at page 85.

BORATES.—Compounds formed of boracic acid and oxides. The alkaline borates are soluble in water. All others are insoluble. They are readily fusible, and are used as fluxes for other bodies; borax, in particular, is much used in assaying and in experiments made with the blowpipe.

The constitution of the neutral borates is represented by the formula MBO ; but they often occur with excess of acid, such as $\text{MBO} + \text{BBO}$. Thus, the most common of all the borates, *Borax*, has the very complex constitution that is represented by the following formulæ:—

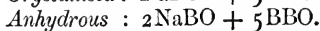

In all the compounds of this description, the atoms of boron *plus* the atoms of the basic radical are equal to twice the number of the atoms of oxygen. Boracic acid, which is a feeble acid when in liquid solutions, becomes, when fused at a white or red heat, a very powerful acid, and expels all other more volatile or more decomposable acid radicals from basic radicals, and thus produces anhydrous borates; in which particular boracic acid acts somewhat like phosphoric acid.

Detection of Borates.—See page 95.

Chloride of Boron. Formula, BCl ; Equivalent, 39; Specific gravity of gas, 58.5; Atomic measure, $\frac{1}{2}$ volume.—A pungent acid gas, which forms thick vapours in the air. Decomposed by water into hydrochloric and boracic acids:—



Fluoride of Boron. Fluoboric Gas. Formula, BF ; Equivalent, 22.5; Specific gravity of gas, 33.75; Atomic measure, $\frac{1}{4}$ volume; *Systematic name*, Bora fluora.—Prepared by distilling, at a very high temperature, in a porcelain retort, or a wrought-iron tube, a mixture of two parts of fluorspar and one part of fused boracic acid. The products are fluoride of boron and borate of lime:—

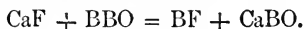

The fluoride of boron is a gas which forms very thick, suffocating acid vapours when let into moist air, in consequence of its powerful attraction for water, which absorbs 700 times its volume of this gas. White paper plunged into this gas instantly turns coal black: the reason is, that the paper is decomposed, and new compounds are formed by the oxygen and hydrogen of the paper and the elements of the fluoride of boron. The charcoal of the paper is thus set at liberty.

Borofluoric Acid.—The saturated solution of the above gas in water. This may be prepared by distilling a mixture of equal parts of fluorspar and borax with concentrated sulphuric acid in a glass retort. The distillate is a very acid liquor.

Hydrofluoboracic Acid is produced when borofluoric acid is largely diluted with water. One fourth of the boron separates as boracic acid:—

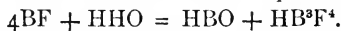

This quadruple salt = $\text{HB}^3\text{F}^4 = \text{HF} + 3\text{BF}$, contains one replaceable atom of hydrogen, which it can exchange for a metal and produce a neutral salt. A similar salt is produced by adding boracic acid to a dilute solution of fluoride of potassium:—

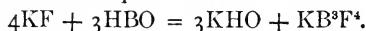

Nitride of Boron. $\text{NB}^2 + \text{B}$.—In a current of steam it produces acid borate of ammonia:—



19. SILICON.

Symbol, Si; *Equivalent*, 7. *It does not form a gas. When it acts as an acid radical in salts, it has no atomic measure. It condenses all radicals with which it combines to form gaseous salts from 1 volume to $\frac{1}{2}$ volume.*

Occurrence.—See page 10.

Properties.—Silicon is a dark-brown powder, without metallic lustre. When heated in the air, it burns on the surface to silicic acid (silica), which coats the unburned silicon. The residue can be dissolved only by a mixture of nitric acid and hydrofluoric acid. When silicon is mixed and heated with carbonate of potash, it is readily oxidised at a temperature lower than a red heat. Chlorine gas passed over heated silicon produces volatile chloride of silicon.

Preparation.—See pages 705 and 707.

Silicon is a very important substance in the mineral kingdom. With oxygen it forms silica; with oxygen and hydrogen it forms hydrate of silicic acid; with oxygen and metals it forms silicates. It is extremely abundant. One-third part of the weight of most of the mountains in the world consists of silica.

SILICIC ACID. *Silica.*— Si, SiO . Equivalent 30.

A white powder, insoluble in water, infusible, inodorous, tasteless, gritty. Native rock-crystal consists of silica nearly in a state of purity. The most usual form of the crystals is that of six-sided prisms terminated by six-sided pyramids. Common sand is impure silica. Quartz, flint, and other siliceous minerals, consist of silica in various states of impurity. Siliceous stones are harder than window glass, but softer than the diamond. It is insoluble in all acids except the hydrofluoric acid, and it can only be brought into solution by fusion with a fixed alkali. Newly precipitated, it is soluble in water. See page 706.

Preparation of Silica.—Transparent specimens of rock-crystal are ignited, thrown, while red-hot, into water, to render them brittle, and then reduced to powder in an agate mortar. Silica thus prepared is not quite pure. To obtain it pure, it must be melted with three or four parts of dry and pure carbonate of soda in a platinum crucible. This requires the heat of a furnace. After the fusion, the mass is to be taken from the crucible, put into a porcelain basin, and dissolved in pure hydrochloric acid. The silica will then be perceived to have the consistency of jelly. The mixture is to be slowly evaporated to dryness, all lumps formed during the evaporation being broken down with a glass rod. When the residue is in the state of a fine dry, nearly white, powder, it is to be moistened with a little strong hydrochloric acid, to be well mixed with a glass rod, and allowed to rest for twenty minutes. Water is then to be added in considerable quantity, whereupon the chloride of sodium, with the chloride of iron, and other impurities, will dissolve, and the silicic acid will remain undissolved. It is to be

brought upon a paper filter, placed in a funnel, and to be washed as follows:—Let *d* represent the funnel which contains the silica on a filter; then water is to be boiled in the flask *a*, and the steam is to be conveyed from it by means of a bent glass tube, *b*, of one-fifth of an inch bore, into the funnel *d*. Both ends of this tube are ground aslant, so that no drops of water can obstruct the passage. The funnel is covered by a very shallow glass capsule, *c*, which has a hole in the middle

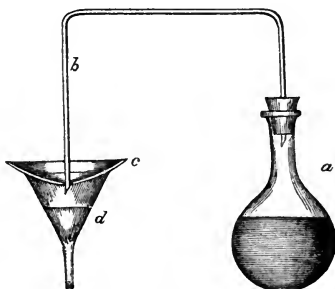

just large enough to admit the tube *b*, and the end of this tube must barely pass through the cover, and not touch anything within the funnel. As the steam passes into the funnel, it is condensed into boiling-hot water, which passes through the powder that is to be washed, and drops from the neck of the funnel, carrying all soluble matters with it. The pressure of the steam and the high temperature are both advantageous in facilitating the rapid washing of the precipitate. If the steam comes off too fast, the excess blows out between the funnel and the cover, and does no harm. But it is easy, when the water is boiled by a gas flame, to provide against waste of steam. The only accident to which this method of washing is liable is that of water gathering so much in the funnel as to cover the end of the tube; but a very little attention to the ebullition of the water suffices to prevent this occurrence.

Test of the Purity of Silica.—The washing of the silica is completed when the drops of water that pass from the funnel give no precipitate with a solution of nitrate of silver. The silica so prepared should be perfectly white, and when fused with carbonate of soda before the blow-pipe, should give a colourless glass bead.

Another method of preparing pure (and soluble) silica is described in the article on hydrofluosilicic acid, page 705.

SILICATES.—Silica combines with metallic oxides to form compounds that are called *Silicates*, all of which are insoluble in water, except the silicates of fixed alkalies containing a great excess of base. Very many rocks and siliceous minerals consist of silicates, and especially of combinations of silica with alumina, lime, magnesia, oxide of iron, potash, soda, and more rarely oxide of manganese. Silicates of potash and soda, when the silica is in excess, constitute glass. When silicate of lead is added, the glass is the important variety called *flint glass*. Silicate of alumina is the principal component of all clays and earthenwares. Among the natural silicates, many, such as zeolites, are soluble in heated hydrochloric acid; but others require to be melted with a fixed alkali before they can be dissolved. I have given at page 679 a list of minerals that are soluble in hydrochloric acid.

Constitution of Silicates.—A simple silicate is formed in accordance with the formula $M\text{SiO}$, in which *M* represented any basic radical whatever, *Si* represents one equivalent, or 7 parts of silicon, and *O* one equivalent, or 16 parts of oxygen. The normal silicates thus formed can combine with one another, with anhydrous silica, and with salts formed on the model of water = HHO , thus producing a great variety of complex silicates,—neutral, acid; and basic.

Examples of Silicates :

1. H Si O = Hydrate of silica.
2. $\text{H}^2\text{Si}^4\text{O}^3$ = $2\text{HSiO} + \text{SiSiO}$ = Another hydrate.

3. $\text{H}^3\text{Si}^5\text{O}^4 = 3\text{HSiO} + \text{SiSiO} = \text{Another hydrate.}$
4. $\text{C}^5\text{H}^{11},\text{SiO.}$ Silicate of Amyl. Atomic measure of gas, half a volume.
5. $\text{C}^2\text{H}^3,\text{SiO.}$ Silicate of Ethyl. Atomic measure of gas, half a volume.
6. $(\text{C}^2\text{H}^3)^2,\text{Si}^4\text{O}^3 = 2(\text{C}^2\text{H}^3,\text{SiO}) + \text{SiSiO}$ }
7. $(\text{C}^2\text{H}^3)^2,\text{Si}^3\text{O}^5 = 2(\text{C}^2\text{H}^3,\text{SiO}) + 3\text{SiSiO}$ } other silicates of ethyl.
8. $\text{Ca Si}^3\text{O}^2 = \text{Silicate of lime, a mineral.}$
9. $\text{Ca}^2\text{Si}^4\text{O}^3 = 2\text{CaSiO} + \text{SiSiO.}$ Wollastonite.
10. $\text{Mn SiO} = \text{Tephroite.}$
11. $\text{Mn}^2\text{Si}^4\text{O}^3 = 2\text{MnSiO} + \text{SiSiO.}$ Manganesic Augite.
12. $\text{AlcSiO} = \text{Bucholite.}$
13. $\text{AlcSi}^3\text{O}^2 = \text{AlcSiO} + \text{SiSiO} = \text{Agalmatolite.}$
14. $\text{KAlc}^3\text{Si}^{12}\text{O}^8 = \text{KSiO} + 3\text{AlcSiO} + 4\text{SiSiO} = \text{Felspar.}$
15. $\text{RSiO} + n\text{RcSiO.}$

The last formula may be taken as a very general one adapted to represent mineral silicates. The symbol R signifies one equivalent of any basylous element or of any combination of basylous elements combined together. Thus it may signify (H,K,Na,Ca,Mg,Fe,Mn), combined in any relative proportions whatever, but in such an absolute quantity that the whole shall have the neutralising power of one equivalent or one radical. So also Rc signifies one equivalent of a basylic radical, or such a quantity of different basylic radicals, in any sort of relative proportions, as shall together possess the neutralising power of one equivalent or one radical. In this sense, Rc may represent (Alc,Fec,Crc,Mnc). The formula No. 15, namely, $\text{RSiO} + n\text{RcSiO}$, necessarily resolves itself into the simple unitary formula of $\text{R}^x\text{Rc}^y\text{Si}^z\text{O}^1$, where $x + y + z$ are collectively equal to two equivalents of the radicals $\text{R} + \text{Rc} + \text{Si}$ in combination with one equivalent of oxygen; and this unitary formula is, for a vast variety of complex silicates, the best of all formulæ, because of the extreme state of admixture in which many silicates occur in the mineral kingdom. Take, as an example, the mineral called *Vesuvian*, the composition of which is $= \text{Ca}^8\text{Mg}^1\text{Fec}^1\text{Alc}^8\text{Si}^{18}\text{O}^{18}$. This is evidently very little removed from $\text{CaSiO} + \text{AlcSiO}$, the vicarious elements being only 1 in 9. If it is expressed in an analytical formula, it becomes $8\text{CaSiO} + \text{MgSiO} + 8\text{AlcSiO} + \text{FecSiO}$. But the unitary formula gives this information quite as clearly and more briefly. Another form of formula for such compounds might be this: $-(\text{Ca}^8\text{Mg}^1)(\text{Alc}^8\text{Fec}^1)^1\text{Si}^2\text{O}^2$.

The reader who desires to investigate the constitution of the silicates more thoroughly is referred to my work on the Radical Theory, where the subject is treated fully, and this theory and its results are contrasted with the prevailing theories and the consequences which flow from them.

CHLORIDE OF SILICON.

Formula, SiCl₄; Equivalent, 42.5; Specific gravity of gas, 85; Atomic measure, $\frac{1}{2}$ volume; Systematic name, Sila chlora.

When silica is heated in a current of chlorine gas it produces chloride of silicon, which can be prepared more economically by the following indirect process. Prepare finely-divided silica by decomposing silicate of potash with an acid. Mix this silica with an equal weight of lamp-black, and with the help of some oil make it up into little balls. Roll these balls in charcoal powder, and heat them to redness in a closed crucible. Arrange the apparatus represented in fig. 534. The flask

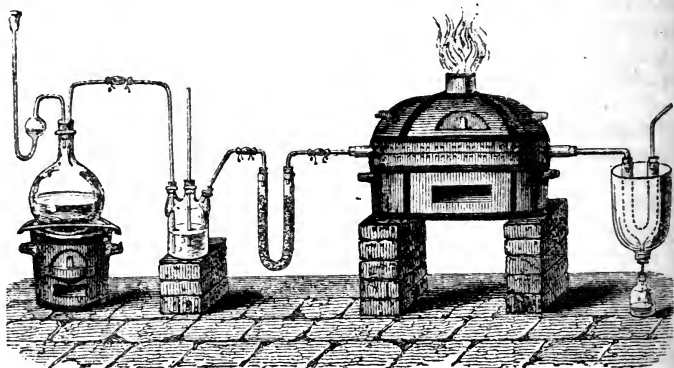

534.

on the left hand is for the preparation of chlorine gas, the Woulff's three-necked wash-bottle is to purify that gas, and the U-tube is to contain materials for drying it. See page 664. The tube placed in the long furnace is to be filled with the porous balls spoken of above. The U-tube on the right hand is to be placed in a good freezing mixture, and is to have a descending branch, as shown in the figure, for the purpose of delivering the condensed distillate into a bottle placed below in a separate freezing mixture for its reception. The liquor thus procured is chloride of silicon. There is a simultaneous production of carbonic oxide, which passes away from the extreme end of the last U-tube.

Theory.—Chlorine alone will not decompose silica at any temperature; neither will carbon; but chlorine and carbon acting together easily decompose it:—

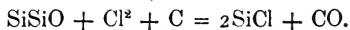

Properties.—A transparent colourless liquid possessing an irritating acid odour. Very volatile; fuming in the air. Decomposable by water, which produces hydrochloric acid and hydrated silicic acid:—

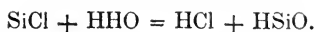

If potassium is heated in the vapour of SiCl, silicon is set free, and chloride of potassium is produced. According to Berzelius, this is one of the best methods of procuring silicon.

FLUORIDE OF SILICON.—*Formula*, SiF; *Equivalent*, 25; *Specific gravity of gas*, 5.2; *Atomic measure*, $\frac{1}{2}$ volume; *Systematic name*, Sila fluora.

Mix intimately equal parts of fluorspar and pounded glass or ground flint. Put a quantity of this mixture into a gas-bottle with as much strong oil of vitriol as will produce a thin paste. The mixture must be stirred or well shaken. It swells considerably during the subsequent action, so that a capacious flask is necessary. A partial disengagement of gas takes place immediately, but after some time a gentle heat must be applied to promote the action. The gas thus prepared is fluoride of silicon, SiF. It dissolves and is decomposed so readily in water that it must be collected over mercury, and the vessels to contain it must all be thoroughly dried. It is transparent and colourless, but it gives thick white fumes in moist air. It is very dense, its specific gravity being 5.2. It is, consequently, $3\frac{1}{4}$ times heavier than oxygen gas. Its chief use is in preparing the following acid.

HYDROFLUOSILICIC ACID = $\text{H Si}^2\text{F}^3 = \text{HF} + 2\text{SiF}$.—When gaseous fluoride of silicon is passed into water, one-third of it is decomposed, and the remaining two-thirds combine with part of the products of the decomposition, as represented in the following equation:—

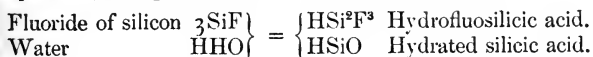

The hydrofluosilicic acid dissolves in the water. The silicic acid, in a gelatinous form, separates from the solution. This process may be followed either to procure the hydrofluosilicic acid to use as a test, or as a method of preparing soluble silica. I shall describe several forms of apparatus which may be used, according to the quantity of materials operated upon at one time.

1. A small quantity of the acid may be prepared by means of the tube apparatus, fig. 303, in page 301. The materials to produce the fluoride of silicon are to be put into the retort *a*, the joint at *d* is to be made tight, and as much mercury is to be put into the receiver at *c* as barely closes the passage. As the gas passes into the branch *b*, it may be examined, that is to say, its fuming properties may be seen and its action on litmus paper may be tested. The branch *b* is then to be nearly filled with water, upon which the gas, as it rises through the mercury, will be converted into the hydrofluosilicic acid, under a visible deposition of gelatinous silica.

2. The apparatus, fig. 535, serves for the preparation of a quantity of this acid. It is a combination of instruments very useful in many

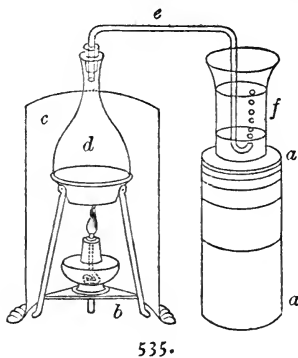

cases where a gas is to be passed into a liquor. *d* is the gas-bottle in which the gas is prepared; *e* the gas-delivery tube passing into the liquor. In the present case, however, the tube passes into a stratum of mercury placed below the liquor, in order to prevent the stoppage of the tube by deposited silica, which is almost sure to occur if the tube dips into the water. *b* is a tripod support for the bottle, having a shelf to support the spirit-lamp; *c* is a screen of zinc which can be shifted round the apparatus to cut off drafts of air from the lamp; *a a* are a series of

blocks of wood by which the jar *f* can be adjusted to any level rendered necessary by the length of the tube *e*.

3. The apparatus represented by fig. 536 is adapted for use when a large quantity of silica or of hydrofluosilicic acid is required. It is the same in principle as the apparatus last described. The only addition is the safety-tube *b*. This is added to prevent an explosion in the event of the possible obstruction of the gas-delivery tube. This might happen by the gradual accumulation of moisture in the tube and the deposition of silica arising from that accident. In such a case the acid in the safety-tube would blow out and allow the gas to escape by the funnel.

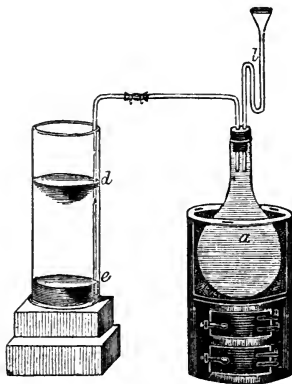

The silica deposited in this operation has a very curious appearance. It often forms worm-like tubes of silica, rising up through the water. These must be broken down by a glass rod, otherwise part of the gas will escape through them into the air. When the operation is ended, the liquor may be filtered through a clean linen cloth, and be squeezed from the silica. The latter cannot be washed, because in this condition silica is easily soluble in water. The silica can be afterwards purified by ignition and subsequent washing.

The hydrofluosilicic acid cannot be separated from water. Evapora-

CHROMIUM.

20. THE CHROMOUS RADICAL = Cr. *Equivalent*, 27.

21. THE CHROMIC RADICAL = Cr. *Equivalent*, 18.

The distinction between these two radicals is, that the chromous radical acts as an acid radical, and the chromic radical as a basic radical. Each of these radicals is readily changeable into the other by a proper arrangement of circumstances. Chromium, as an acid radical in a gaseous salt, has no atomic measure, and no condensing power on other radicals.

Occurrence in Nature.—The salts of chromium, that are used in the arts, are prepared from a mineral which is called *Chrome Iron Ore*, the composition of which is represented by the following formula:—

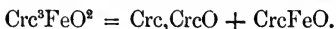

The chrome iron ore never occurs pure in nature, the chromic radical being subject to replacement by the aluminic radical, and the ferrous radical by magnesia. The proportions of the ingredients, however, answer in all cases to the formula $\text{Rc}^3\text{R}'\text{O}^2$; so that this mineral agrees in its habitudes towards vicarious radicals with the silicates. The following are examples of such replacements, as demonstrated by analyses:—

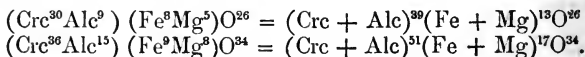

Both of these formulæ are equivalent to the formula

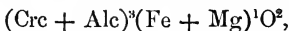

and they show that the chromic and aluminic atoms are equivalent to each other, while magnesia is equivalent to the ferrous atom.

Other minerals which contain chromium do not occur in sufficient abundance to be used economically. The principal are these:—

Red Lead Ore = PbCrO^2 , which is a neutral chromate of lead.

Phonikochroite = $3\text{PbCrO}^2 + \text{Pb}^3\text{CrO}^3$, a compound of three atoms of neutral chromate of lead with one atom of terbasic chromate of lead.

Vauquelinite = $3\text{PbCrO}^2 + \text{Cuc}^2\text{Pb}, \text{CrO}^3$, containing three atoms of neutral chromate of lead with one atom of a terbasic chromate, which includes both copper and lead. Many other minerals contain chromium in small quantity as colouring matter. It is so found in serpentine and in the emerald and the ruby.

Metallic Chromium is very little known, if at all. When the oxide is heated with charcoal for several hours at the highest heat of a wind furnace, a porous mass is procured, which is only imperfectly fused, and presents some hard, metallic, brilliant, brittle points, which are probably a carbide of chromium = $\text{C} + n\text{Cr}$. Another kind of chromium is

obtained when dry ammoniacal gas is passed over ignited chloride of chromium. This product is a chocolate-brown powder. But this and other recorded reductions of chromic compounds do not show the production and properties of metallic chromium conclusively. Perhaps, metallic Cr and CrC have different properties.

CHROMOUS SALTS.

These contain the radical Cr = 27, which acts as an acid radical.



In the present case, as often elsewhere, in explaining my views of the constitution of radicals and of salts, I am greatly hampered by the existing nomenclature, which conveys ideas quite the contrary to what are desirable, and yet cannot be avoided. The chromic atom CrC, is unquestionably the equivalent of the ferric atom FeC; the chromous atom Cr is not the equivalent of the ferrous atom Fe, but of the sulphuric atom S; for the chromic acid HCrO^2 is the equivalent of the sulphuric acid HSO^2 . In the acid HCrO^2 we have the *chromous* radical, but we have, and we must at present use, the name of *chromic* acid, and thus the *thing* and the *name* come to be in direct opposition to one another. The difficulty would be overcome by changing the name of the acid according to the principles of the nomenclature proposed in this work; but as I have already said, I am forced to use the existing nomenclature, however troublesome and defective.

Properties of the Anhydrous Acid = Cr, CrO³. — Bright crimson-coloured crystals, sometimes fibrous. Fusible at about 400° F. to a dark-red liquor. Without odour. Taste acid and bitter. Stains the skin yellow, removable by alkali. The crystals deliquesce in the air, and readily dissolve in water, producing when concentrated a dark-red, and when dilute a bright-yellow colour. The chromic acid combines with oxides to form chromates.

When strongly heated, the anhydride becomes incandescent, gives off oxygen gas, and is converted into chromic oxide. Thus:—



In consequence of this ready convertibility of Cr into CrC, and therefore of chromic acid into chromic oxide, under disengagement of half its oxygen, this compound is much used as an oxidising agent.

Hydrated Chromic Acid = H, CrO². — When the crystals of the anhydrous acid are dissolved in water, the solution may be assumed to contain this hydrate, for—

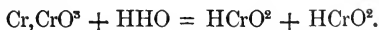

The acid is, like some of the salts of ammonium, not known in the

isolated or solid state, but its solution behaves precisely as if the salt HCrO^2 was present in it, combining with hydrated oxides to form chromates under separation of an equivalent of water. Thus:—

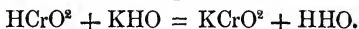

I have no hesitation, therefore, in assuming that the aqueous solution of the chromic anhydride contains the chromate of hydrogen or hydrated chromic acid.

Preparation of Chromic Anhydride.—Prepare a hot saturated solution of bichromate of potash, and let it cool. Pour two measures of the cold solution into three measures of concentrated oil of vitriol, of sp. gr. 1.84, stirring the acid actively, while the solution is being added. Place the porcelain capsule on a straw support, and immediately cover it with a piece of board made to fit it as close as possible. At the end of three hours, a quantity of dark crimson-coloured crystals will be observed in the solution. These are chromic acid. Pour off the red liquor, and put out the crystals with a spatula on a tile or flat piece of absorbent pottery. Cover them with a glass jar, and put sand round the mouth to keep off the air. In two days the crystals will be dry. They contain a little sulphuric acid, which may be separated by solution in very little water, and crystallisation over oil of vitriol in an exhausted receiver. The red residual liquor gives off oxygen gas when boiled.

Experiments Illustrating the Properties of Chromic Anhydride, after Böttger.

1. *Reduction of Chromic Acid.*—It has commonly been considered that chromic acid dissolves in alcohol, producing a solution which is decomposed both by light and heat. According to my observations, *alcohol is decomposed instantaneously by dry chromic acid*, frequently under a considerable disengagement of light and heat.

2. If, for example, dry chromic acid is thrown into absolute alcohol, the acid becomes ignited and suffers deoxidation. The liberated oxygen combines with the alcohol, and produces that highly odorous solution of aldehyde, which commonly bears the name of lampic acid.

3. If about a teaspoonful of dry chromic acid is placed in a porcelain capsule and moistened with a few drops of absolute alcohol, the latter immediately inflames, while the reduced portion of the chromic acid continues for some time in a state of ignition.

4. If absolute alcohol is mixed with a little sulphide of carbon, we obtain a mixture which bursts into flame on the addition of even the smallest portion of dry chromic acid; yet sulphide of carbon by itself is not in the least degree affected by dry chromic acid.

5. If a white glass bottle of the capacity of twenty ounces of water is filled with alcohol vapour mixed with atmospheric air, and a small quantity of dry chromic acid is thrown into it, the almost immediate

result is an explosion. No danger attends this experiment, if the bottle is left open when the acid is put into it.

6. As soon as the explosion referred to in the last experiment has occurred, a few drops of absolute alcohol are to be poured into the bottle as quickly as possible, a little more dry chromic acid is to be added, and the bottle is to be closed. The atmospheric air in the bottle having been expelled by the previous explosion, the mutual decomposition of the chromic acid and the alcohol now proceeds quietly, yet in a manner highly interesting. If, for example, the experiment is made in a darkened chamber, then the chromic acid produced in the operation in a state of fine division, is observed to circulate about the glass, perfectly red-hot, for a long time. The most striking thing connected with this part of the experiment is, that every little atom, like a brilliant meteor, *turns with inconceivable rapidity about its axis*, swimming round about in the newly-produced aldehyde atmosphere, and continuing in this state of strong ignition, as long as the least trace of undecomposed alcohol remains within the vessel. On many occasions these extremely interesting phenomena are perfectly visible even in daylight, and sometimes continue for nearly ten minutes.

7. If a current of dry ammonia gas is thrown upon crystallised chromic acid, combustion occurs, and the chromic acid is reduced to chromic oxide.

8. Fit a glass spirit-lamp with a thick wick of asbestos instead of cotton. Fill the lamp with common alcohol, or with alcohol mixed with sulphide of carbon. Cut the wick square across, at a quarter of an inch above the wick-holder, spread it out into a brush, and moisten it with a few drops of absolute alcohol, and put upon it a small quantity of anhydrous crystallised chromic acid. The alcohol immediately bursts into flame, and the chromic acid becomes white-hot and is reduced to green oxide of chromium. Blow out the alcohol flame. The oxide of chromium then continues to burn at a red heat, and the combustion of the alcohol is kept up precisely as if spongy platinum were employed.

CHROMATES.—*Detection.* Page 96.

The neutral chromates of alcalies and earths are yellow; the bichromates are red, and communicate these colours to their solutions in water. The insoluble chromates of the heavy metals possess yellow, red, or other brilliant colours. When heated with oil of vitriol, they disengage oxygen gas; with hydrochloric acid, they disengage chlorine gas: in both cases producing green solutions. These decompositions deserve special attention, and I will state them in equations:—

a). *With Oil of Vitriol they disengage Oxygen Gas.*

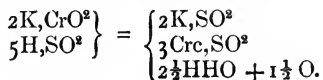

The two atoms of Cr produce three atoms of Cr₂O₃, and having then become basic, they need three times SO₃ to neutralise them. Five atoms of HSO₃ give off 5H, which take up 2½O to form water, and set 1½O at liberty. An additional quantity of HSO₃ would not take up this free oxygen.

b). *With Hydrochloric Acid they give off Chlorine Gas.*

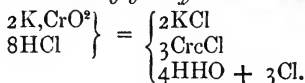

This differs from example a), by showing the disengagement of chlorine instead of oxygen. This difference results from that play of affinities which enables nascent oxygen to take hydrogen from hydrochloric acid. In both examples, two atoms of acid chromium are converted into three atoms of basic chromium.

When heated with chloride of sodium and oil of vitriol together, the chromates give off oxychloride of chromium in bright red vapours. See page 713. All the chromates are soluble in nitric acid.

Precipitates produced by Solutions of Chromates:—

PALE YELLOW	Barium.	Tin, stannous salt.
BRIGHT YELLOW	Lead.	Bismuth.
ORANGE	Mercuric salts.	
BRICK-RED	Mercurous salts.	
BROWN-RED	Silver.	Copper.

Constitution of the Chromates. The normal chromates agree with the formula MCrO₃. They make many compound salts, but none that agree with the acid bisulphates, namely, such as have the formula MCrO₃ + HCrO₃. But they have the peculiarity of producing salts which are compounds of neutral chromates with chromic anhydride, of which salts the following series contains examples:—

KCrO₃ + CrCrO₃. Anhydrous terchromate of potash. Forms dark-red crystals.

2KCrO₃ + CrCrO₃. Anhydrous bichromate of potash. The usual red salt of commerce.

PbCrO₃ + Pb²CrO₃. Anhydrous dichromate of lead. Beautiful scarlet crystals.

KCl + CrCrO₃. A compound of chromic anhydride with chloride of potassium. Orange-coloured crystals.

Cr₂CrO₃ = CrCrO₃ + Cr₂CrO₃. This is a tribasic chromate, in which the three basic radicals are Cr₂, and the acid radical is Cr. This is the brown oxide of chromium, or the chromate of chromic oxide.

KCrO₃ + MgCrO₃ + HHO. A double chromate of potash and magnesia. A similar salt occurs with lime instead of magnesia.

AmCrO₃ + 5HCrO₃ + 2½Aq. A very acid chromate of ammonia, in which we have the hydrated chromic acid HCrO₃ in great excess.

NEUTRAL CHROMATE OF POTASH. KCrO^2 .—Beautiful yellow crystals of the form of sulphate of potash, easily soluble in water, giving a yellow solution, possessed of extraordinary colouring properties.

BICHROMATE OF POTASH. $\text{KCrO}^2 + \text{KCrO}^2 + \text{CrCrO}^3$.—Forms large easily fusible crystals, distinguished by a splendid red colour, which it communicates to its aqueous solution.—Bichromate is obtained by adding nitric acid to the solution of the neutral salt, and crystallising the mixture.—Neutral chromate can be prepared by adding caustic potash to the bichromate. The neutral chromate does not crystallise so readily as the bichromate.

Bichromate of potash is used in dyeing, in which, with salts of lead, it produces most beautiful yellow and red colours. It is also the material employed to produce all other compounds of chromium, several of which are employed as pigments. Some of the precipitates given by a solution of chromate of potash are noticed at page 712.

CHROME YELLOW.—This pigment is the chromate of lead = PbCrO^2 . The beautiful red *dichromate* of lead, noticed above, is obtained by fusing an atom of the neutral chromate of lead with an atom of saltpetre.

The chromates of silver, mercury, barytes, &c., require no particular notice. They are prepared by precipitation, and possess the general properties of chromates, and the properties of the particular bases. See their colours, page 712.

Chromous Chloride = CrCl = *Chromous chlora*.—Produced by the action of pure dry hydrogen at a red heat, on chromic chloride, CrCl_3 .



It is a white substance, which forms a blue solution in water, and is rapidly decomposed by absorption of oxygen.

OXYCHLORIDE OF CHROMIUM.

Formula, ClCrO ; *Equivalent*, 78.5; *Specific gravity of gas*, 78.5; *Atomic measure*, 1 volume, which is the measure of the chlorine, the chromium and oxygen having no measure; *Systematic name*, *Chlora chromousate*. [If formulated CrClO = *Chromous chlorate*.]

Preparation.—Melt 10 parts of chloride of sodium with 16.9 parts of neutral chromate of potash in a Hessian crucible. Pour out the mass. Break it into coarse pieces, and put them into a large tubulated retort, and apply a receiver. Add 30 parts of fuming, or of very concentrated sulphuric acid. The distillation commences immediately, without the application of heat. The oxychloride of chromium must be collected in a receiver effectively cooled by water. A little heat must be applied near the end of the distillation.

Theory:—

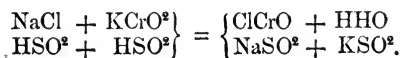

Properties.—A splendid blood-red liquor, of sp. gr. 1.71, very volatile and fuming. At about 250° F. it forms an orange-coloured gas. If poured into water it produces hydrochloric acid and chromic acid:—

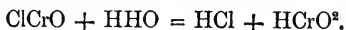

Phosphorus put into it occasions a fiery explosion. Sublimed sulphur moistened with it takes fire. Put a little of it into a V-tube, and pass dried ammonia gas over it: the mixed vapours take fire. When mixed with oil of turpentine, or with absolute alcohol, it inflames.

Ter-Fluoride of Chromium. = CrF^3 , or $\text{CrF}^2 + \text{F}$.—Distil in a platinum retort a mixture of 4 parts of chromate of lead, 3 of fluorspar, and 8 of oil of vitriol. The products are sulphates of lead and lime and fluoride of chromium. The latter is a deep-red vapour, which condenses to a blood-red liquor.

Theory :—

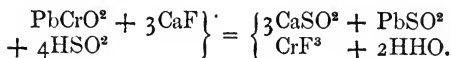

The ter-fluoride of chromium is instantly decomposed by water, producing chromic anhydride and hydrofluoric acid:—

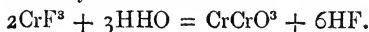

CHROMIC SALTS.

These contain the radical CrC = 18, acting as a basic radical.

CHROME IRON ORE = Cr^2FeO^2 . *Chrominic ferrousete.*—This is the mineral from which all the salts of chromium are prepared, by the following process:—The chrome iron-stone is reduced to the finest possible powder, mixed with three times its weight of carbonate and nitrate of potash, and exposed in a crucible to the heat of a reverberatory furnace. The mixture should be frequently stirred to facilitate its oxidation. After a sufficient fusion, the mass is dissolved in water, the yellow solution is filtered, and mixed with nitric acid, which precipitates silica, from which it is filtered. The liquor on evaporation yields crystals of bichromate of potash, which are purified by re-crystallisation. All the other salts of chromium are prepared from the bichromate of potash.

CHROMIC OXIDE. *Green Oxide of Chromium. Sesquioxide of Chromium* = $\text{CrC}, \text{CrC}^2\text{O}$. *Equivalent, 52.*—An insoluble, infusible, bright green powder, nearly insoluble in acids after ignition, and very difficult of reduction. It is used to paint emerald green on porcelain, and to give the same colour to glass.

Hydrate of Oxide of Chromium. $\text{H}, \text{CrC}^2\text{O}$.—A dull bluish-green powder. At a red heat it loses its water, and is changed into the anhydrous green oxide.

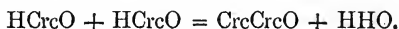

Preparation.—1. Ignite chromate of mercury in a small porcelain crucible over the spirit-lamp. Anhydrous green oxide of chromium CrCrO remains. 2. Make a solution of chromate of potash in a tube, add a little hydrochloric acid and alcohol, and boil the mixture. The original yellow solution becomes green. Add caustic ammonia, which gives a precipitate of green hydrate of chromium HCrcO . Bring it on a filter, and wash it thoroughly with water. 3. Expose 100 grains of bichromate of ammonia on a flat porcelain capsule to the heat of a small spirit-lamp. In a few minutes the whole is decomposed by a violent reaction, accompanied by vivid combustion, and pure oxide of chromium is produced in large films resembling tea-leaves.

A Volcano.—Take 48 parts of fine gunpowder, 240 parts of bichromate of potash, and 5 parts of sal ammoniac, all in dust-dry fine powder. Mix well and sift through a fine sieve. Fill with the dry mixture a conical but not very tall glass. Press a piece of tin-plate on the top, invert the whole, and remove the glass, leaving the powder in the form of a cone. Apply to the summit a piece of lighted tinder, upon which the mixture will take fire, and burn slowly and quietly to the bottom. Collect and wash the residue, which will consist of very fine bright green anhydrous oxide of chromium.—*Böttger*.



SALTS OF CHROMIC OXIDE. *Detection.* Page 91.

They are generally green, but their solutions have sometimes an amethyst colour. The examination before the blowpipe of the green precipitate produced in their solutions by alcalies leads to certain detection.

Conversion of Chromic Oxide into Chromic Acid.—Ignite a mixture of chlorate of potash and chromic oxide in a tube of hard glass. Oxygen and chlorine are given off, and chromate of potash may be extracted from the residue by solution in water, filtration, and crystallisation.

Theory:—

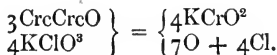

Reduction of Chromic Acid, as existing in the Chromates, to Chromic Oxide.

CHROME ALUM.—Set up the apparatus described, fig. 455, page 595. Put a solution of bichromate of potash into the V-tube, and pass sulphurous acid through it till the solution becomes green. Add sulphuric acid to this liquor till effervescence is occasioned. The spontaneous evaporation of this liquor produces octahedral crystals of *chrome alum*.

The constitution of chrome alum is represented by the following formula:—



CHLORIDE OF CHROMIUM = *Formula*, CrCl ; *Equivalent*, 53.5. *Chromic chlora.*—Dissolve hydrated chromic oxide in hydrochloric acid

$\text{HCrcO} + \text{HCl} = \text{CrcCl} + \text{HHO}$. Let the acid be completely neutralised. Evaporate the solution to dryness. The product is a green mass, which remains so at 212°F . But if it is heated more strongly, it swells up, loses water, and is converted into a peach-blossom coloured chloride, which is nearly but not quite anhydrous.

The strictly anhydrous chromic chlora is produced by passing dry chlorine gas over a red-hot mixture of charcoal and chromic oxide. It forms violet scales. This salt is not soluble in water, but it can be made soluble by a slight admixture of chromous chlora. When the chromic chloride is calcined in the air it gives a beautiful variety of the green chromic oxide.

The following formulæ represent other varieties of chromic salts, the descriptions of which I am forced to omit for want of space:—

The Sulphide	=	CrcS .	
The Sulphate	=	CrcSO^2 .	
The Nitrate	=	$\text{CrcNO}^3 + \text{Aq}^3$.	
Double Oxalate	=	$\text{AmCO}^2 + \text{CrcCO}^2$	+ Aq. <i>Blue salt.</i>
Quadruple Oxalate	=	$\text{AmCO}^2 + 3(\text{CrcCO}^2)$	+ Aq ⁴ . <i>Red salt.</i>

The descriptions usually given in books of the composition of the oxides, hydrates, chlorides, and other salts of chromium, are often very confused. This arises from the circumstances that there has not been a due appreciation of the fact that the function of Cr is to act as an acid radical, and that of Crc to act as a basic radical. Chemists frequently describe the properties of the *salts of protoxide of chromium*, meaning thereby the salts which contain Cr as a basic radical; but it is doubtful whether any such salts exist, except in the case of the chloride.

MOLYBDENUM.

22. THE MOLYBDOUS RADICAL = Mo. *Equivalent, 48.*

23. THE MOLYBDIC RADICAL = Moc. *Equivalent, 16.*

The ores which chiefly yield molybdenum are the bisulphide of molybdenum and the molybdate of lead, both of which are named below. Neither of them are abundant, nor is the metal, nor any of its compounds, of any great importance at present. The use of molybdate of ammonia, as a test for phosphoric acid (see page 94), is the chief of their applications.

The metal is silver white, with a strong metallic lustre, sp. gr. 7.5, extremely difficult of fusion, brittle, and hard. When fused with nitre it produces molybdate of potash.

MOLYBDOUS SALTS.

MOLYBDIC ACID.—The anhydride is Mo_2MoO^3 . This is not soluble in 500 parts of water, and we do not know the hydrated acid, either

solid or in solution. The formula of the salts is $MMoO^2$, in which M represents any basic radical. *Examples* :—

Na, MoO^2	Molybdate of soda.
NH^4, MoO^2	Molybdate of ammonia.
Pb, MoO^2	Molybdate of lead (<i>the ore</i>).
$\left\{ \begin{array}{l} 2(NH^4, MoO^2) \\ 3(H, MoO^2) \end{array} \right\}$	Acid molybdate of ammonia.
$\left\{ \begin{array}{l} 3Moc, MoO^2 \\ H, MoO^2 \end{array} \right\}$	Blue molybdate of molybdenum.

Preparation of Molybdic Acid.—Roast the bisulphide of molybdenum at a low red heat with free access of air. The sulphur is driven off and the metal oxidised. Liquid ammonia then dissolves it, leaving oxide of iron and other mineral impurities, and producing a solution of Molybdate of ammonia. When this is evaporated, and the residue is calcined, the anhydride Mo, MoO^3 is obtained. When this substance is fused with alkaline hydrates or carbonates, molybdates are produced.

BISULPHIDE OF MOLYBDENUM = MoS^2 .—The native sulphide of molybdenum, a mineral which has much the appearance of graphite, but with a paler blue colour.

Quadrisulphide of Molybdenum = MoS^4 .

Chloride of Molybdenum = $MoCl$.

Oxychloride of Molybdenum = $ClMoO$.—Sublimes in yellow scales.

MOLYBDIC SALTS.

These salts are very little known. The radical appears to be basic. I have noticed one of its salts above. Another seems to be Moc^3MoO^3 , usually called the *deutoxide*. The Tersulphide is = $MocS$. The sulphate is $MocSO^2$. It seems probable that the habitudes of the two radicals of molybdenum resemble those of the two radicals of chromium. The molybdous radical Mo is under all circumstances an acid radical, and the molybdic radical is as constantly a basic radical. If this hypothesis is found, on closer examination, to express the truth, it will introduce a new principle by which to discriminate, to separate, and to arrange the radicals and salts of the metallic acids.

VANADIUM.

24. THE VANADOUS RADICAL = V. *Equivalent*, 68·4.

25. THE VANADIC RADICAL = Vc. *Equivalent*, 22·8.

At present this element is only a chemical curiosity. Its most abundant ore is the vanadate of lead = Pb, VO^2 . Before the blowpipe the vanadates fuse with borax into a bead, which is green in the

reducing flame and yellow in the oxidating flame. When boiled with sulphuric acid, and any vinylate, such as sugar or alcohol, they give a blue solution, by which they are distinguished from the chromates, which, under these circumstances, give a green solution. The acid vanadate of ammonia, mixed with tincture of galls, gives a black liquor of intense colour, which is not destroyed by acids, alcalies, or chlorine. If Vanadium could be discovered in quantity, this black liquor would be universally adopted as *writing-ink*, since it very far exceeds in all the good qualities of an ink the liquids that are most in use in that capacity. This is an example of an insignificant element which some day may suddenly become an article of great utility in arts and commerce.

26. TUNGSTENUM.

Formula, W; Equivalent, 92.

This element occurs in two minerals, the Tungstate of Lime, and the Tungstate of Iron and Manganese; the former long known by the name of *Scheelite*, and the latter by the name of *Wolfram*. The symbol for this element, W, is derived from the word *Wolfram*.

TUNGSTENUM, in the fused state, is steel-grey, lustrous, very hard, brittle, and extremely heavy. Its sp. gr. is 17.6. It is exceedingly difficult of fusion. It is commonly obtained in the form of iron-grey powder. When heated in the air, treated with nitric acid, or fused with nitre or alcalies, it produces tungstic acid.

TUNGSTIC ACID.

The Anhydride = W,WO³. The Hydrate = H,WO³.

The Tungstates = M,WO³.

Preparation of Tungstic Acid from Wolfram.—The composition of the mineral *Wolfram*, supposing it to be free from vicarious radicals and other mineral impurities, is represented by the following formula:— $MnWO^2 + 3FeWO^2 = MnFe^3W^4O^8$. The preparation of tungstic acid from this salt consists of operations for dissolving and removing manganese and iron, and leaving the tungstic acid undissolved. The wolfram is very finely pounded, and is digested for a long time with pretty strong hydrochloric acid. The mixture is frequently shaken, fresh acid is supplied from time to time, and towards the end of the digestion a little nitric acid is added, to convert the ferrous radicals into ferric radicals, and insure their solution by the aqua regia produced in the mixture. The digestion is continued until the greater part of the brown powdered mineral becomes yellow. The

acid is then poured off, and the powder is well washed, after which it is shaken up with liquid ammonia, which dissolves out the tungstic acid and leaves undissolved the silica, the undecomposed wolfram, and other impurities. When the ammoniacal solution is evaporated and crystallised, it produces acid tungstate of ammonia, the formula of the crystals of which is $\text{NH}^4, \text{WO}^2 + \text{H}, \text{WO}^2$. When these crystals are heated to redness, they give ammonia, water, and the wolframic anhydride:—

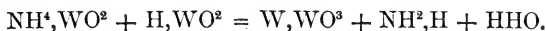

TUNGSTATES.—Tungstic acid is a beautiful straw-yellow coloured powder, tasteless, and insoluble in water, but readily soluble in alkaline solutions, with which it produces tungstates = M, WO^2 . These are mostly without colour. Those of K, Na, L, Mg, and NH^4 , are soluble in water. All others are insoluble. The solutions are disagreeably bitter. They are decomposed by sulphuric, hydrochloric, and nitric acids, which precipitate the tungstic acid, under a form of hydration or of combination, which is not yet properly understood.

Tungstate of Lime. Scheelite. CaWO^2 .—When this salt is boiled with hydrochloric acid, the lime is abstracted, and tungstic acid is set free:—

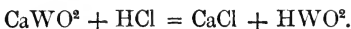

The following secondary reaction produces the anhydrous acid:—

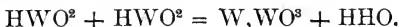

It will very probably be hereafter discovered that tungstenum, like the preceding elements, produces two chemical radicals, a tungstous, or acid radical, and a tungstic, or basic radical.

INCOMBUSTIBLE DRESSES FOR LADIES.—The Tungstate of Soda has recently been recommended by MM. Versmann and Oppenheim as the best material for rendering light fabrics, such as curtains and ladies' muslin dresses, incapable of burning with flame. The process is as follows:—A concentrated solution of neutral tungstate of soda is diluted with water to the specific gravity of 28° Twaddell's hydrometer, and is then mixed with 3 per cent. of phosphate of soda. Into this liquid the washed muslins are dipped, and then dried. It is neither injurious to the colour nor the texture of the fabrics. The iron passes over the material as smoothly as if no such preparation had taken place. The solution increases the stiffness of the fabric, and its protecting power against fire is perfect.

A cheaper material than the tungstate of soda can be employed in cases where ironing of the fabrics is not required. This is sulphate of ammonia, which can be applied in the large way to the finest muslins without injury to their colour, texture, or elasticity. This cheaper salt

cannot be used in the domestic laundry, because it will not bear the process of ironing.

MM. Versmann and Oppenheim have taken out a patent for the use of these substances. See their pamphlet on "*The Comparative Value of certain Salts for rendering Fabrics Non-inflammable.*" These chemists have examined the powers of the borates, phosphates, and other salts previously recommended for this purpose, and found them all to be greatly inferior to those of the two salts named above.

27. TITANIUM.

Formula, Ti; Equivalent, 12.

A rare element, found in the following minerals:—*Titaniferous iron*, the formula of which appears to be $\text{Fe}^x\text{Ti}^y\text{O}^z$, but which is isomorphous with ferric oxide, FecFecO , and combines with it in all proportions, so as to produce minerals of the form $\text{Fe}^x\text{Fec}^y\text{Ti}^z\text{O}^1$, where $x + y + z$ are collectively = 2 against O^1 . The proportions of the vicarious radicals differ in different minerals greatly. *Rutile, Anatase, and Brookite.* These three minerals are all varieties of Titanic acid = Ti, TiO . The hydrate of this acid is = $\text{H}^2\text{Ti}^4\text{O}^3$. The titanates have an equivalent formula = $\text{M}^2\text{Ti}^4\text{O}^3$. They stand, therefore, in the same category as the borates and silicates.

Chloride of Titanium = TiCl , forms a gas; equivalent, 47.5; specific gravity, 95; atomic measure, $\frac{1}{2}$ volume.—A colourless, fuming, volatile liquid.

-
28. TANTALUM = Ta.
 29. PELOPIUM = Pe.
 30. NIOBIUM = Nb.

These are rare and unimportant elements, of which even the weights of the equivalents are unknown. They all occur in different varieties of the mineral called tantalite, or columbite. The reader who may wish to learn what has been discovered respecting them, is referred to the papers which have been published by Professor Heinrich Rose, of Berlin, or to the abstracts of these papers contained in many of the larger systems of Chemistry.

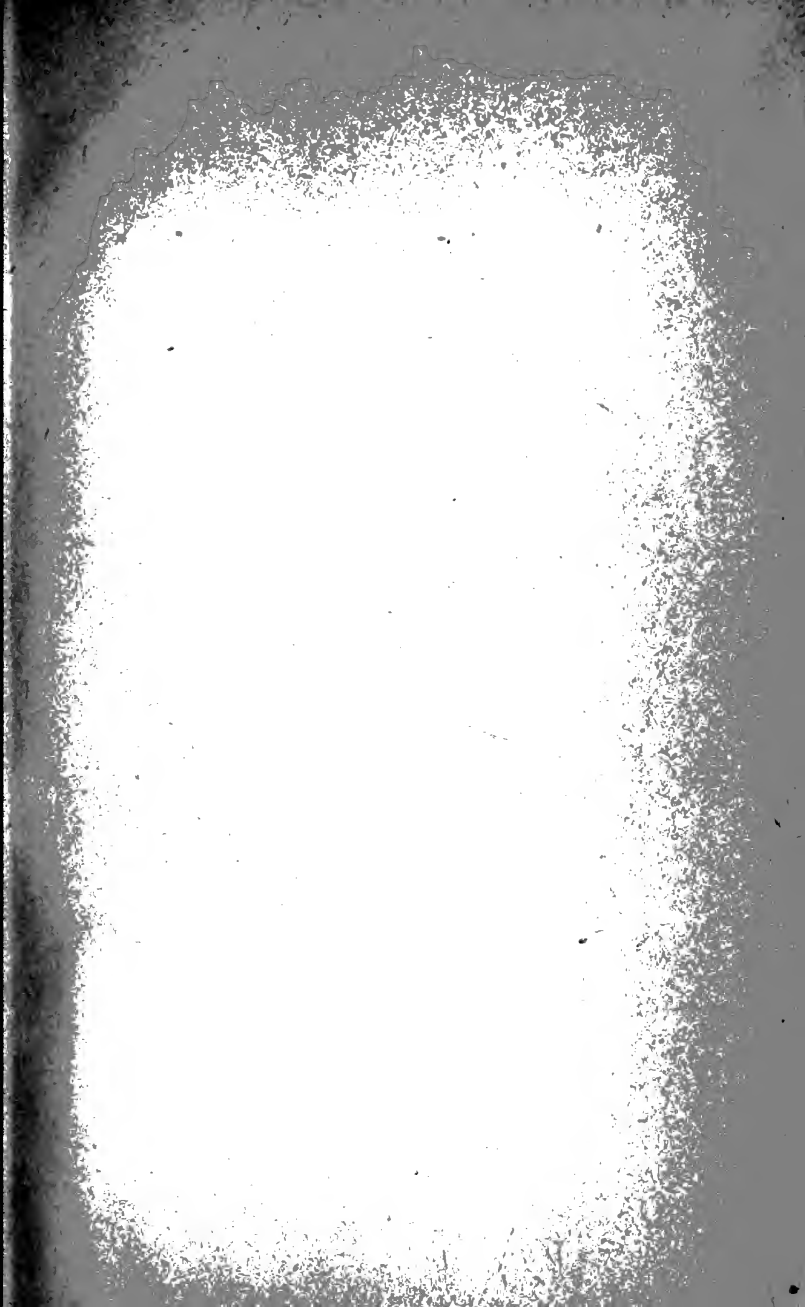

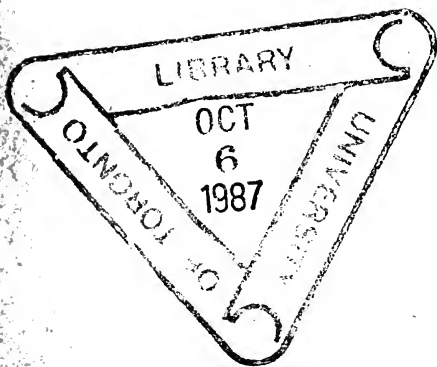

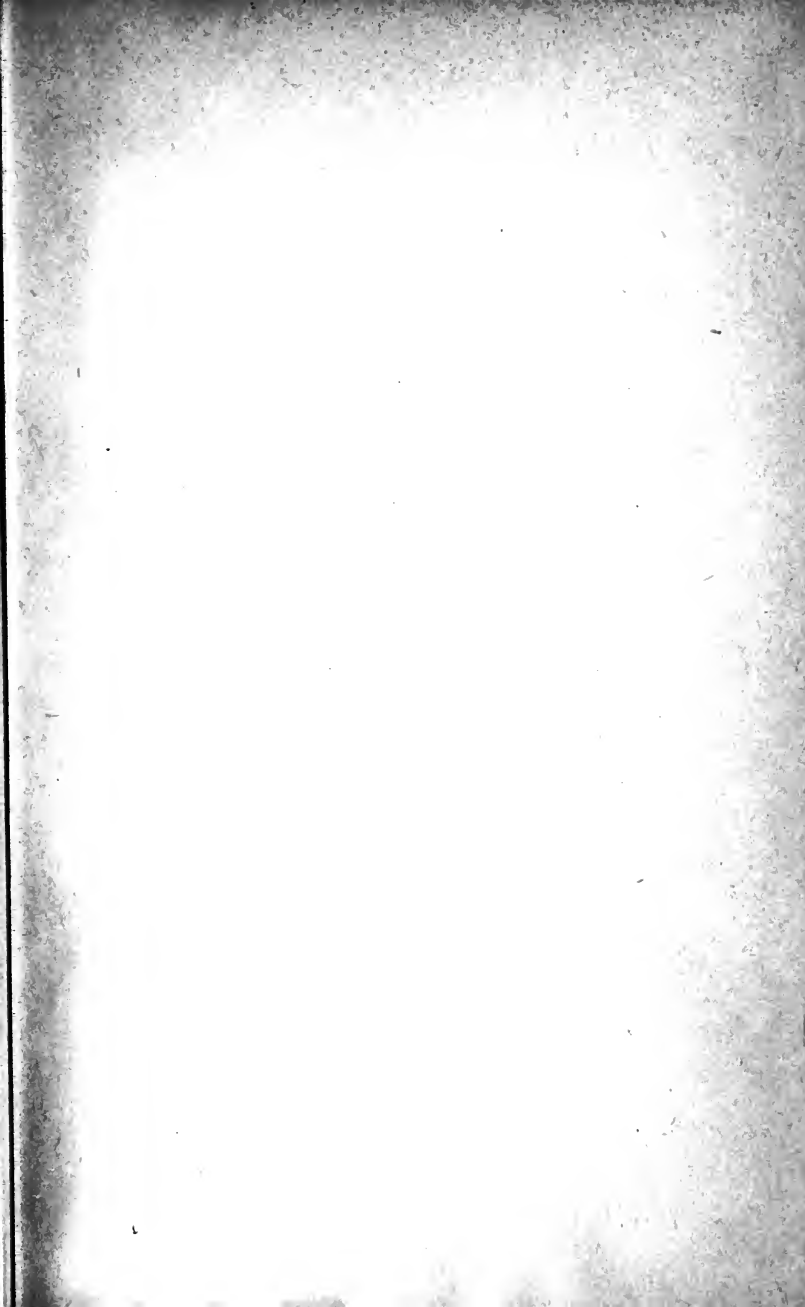

Griffin, John Joseph

3

The Chemistry of the Non-Metallic Elements 2nd Division
1860

ONTARIO
COLLEGE OF PHARMACY
44 GERRARD ST. E.
TORONTO.

QD
45
G74
1854
v.2
PASC

PLEASE DO NOT REMOVE
CARDS OR SLIPS FROM THIS POCKET

UNIVERSITY OF TORONTO LIBRARY



